

Aparador Multi / Windsor 47.24

Console Accent Table

4LC

Click here to access Assembly Video
Haga clic para acceder al Video de Armado

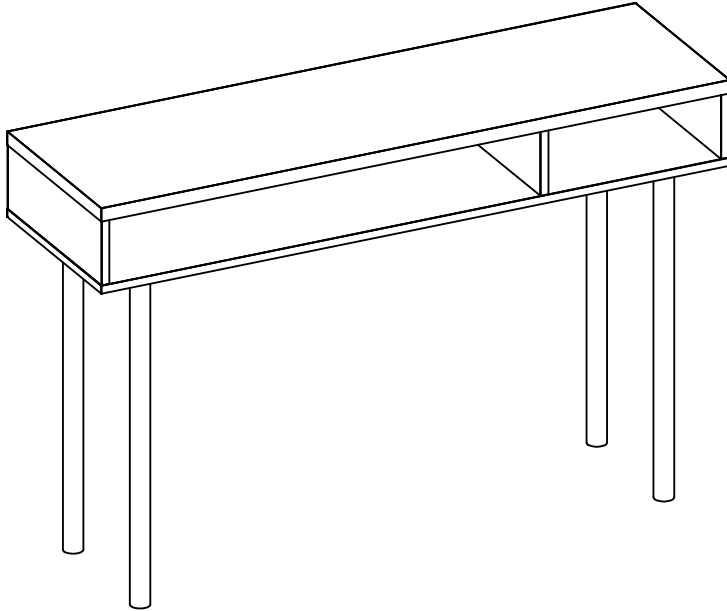
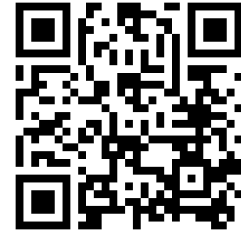

Dimensões/Dimensions/Dimensiones:

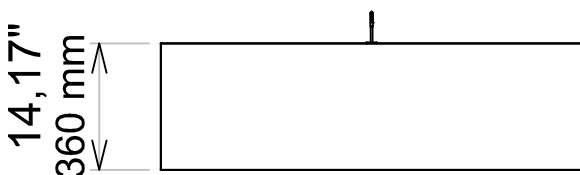
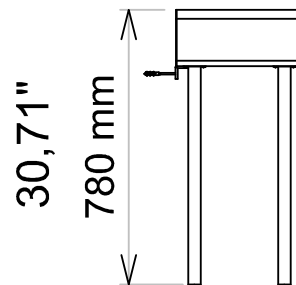
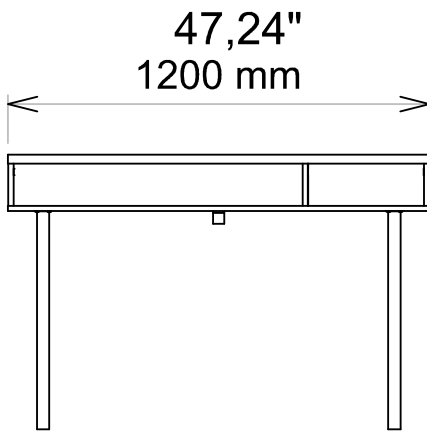

Manual de Montagem
Assembly Instructions/
Instrucciones de Montaje.

Introdução / Introduction / Introducción:

*** Observe atentamente o manual e siga rigorosamente os passos montagem**

*** Antes de começar prepare o ambiente, deixando completamente limpo e Com bom espaço para iniciar a montagem do produto. Use o papelão embalagem própria, bem como proteção de manta isolante para separar e Apoie as peças removidas da caixa. Alinhe a área de montagem com o cobertor isolante, evitando assim danos nas peças durante o processo de montagem, 01**

*** Não instale em superfícies úmidas, absorve umidade.**

*Read the manual and follow the steps for the perfect assembly.

*Prepare the environment before you start. Leave the room completely clean to start the assembly. Use the carton of the box as a protection layer to separate and protect the parts in order to avoid damages. Image 01.

*Don't install it in areas that may be damp, with infiltrations.

*Observe cuidadosamente el manual y siga estrictamente los pasos de montaje.

*Antes de comenzar prepare el ambiente, dejando completamente limpio y con buen espacio para iniciar el montaje del producto. Utilice el cartón del propio embalaje, así como la protección de manta aislante para separar y apoyar las piezas retiradas de la caja. Forra el área de montaje con la manta aislante, así evita avería en la piezas durante el proceso de montaje, Image 01.

*No instalar en superficies húmedas, contener infiltraciones.

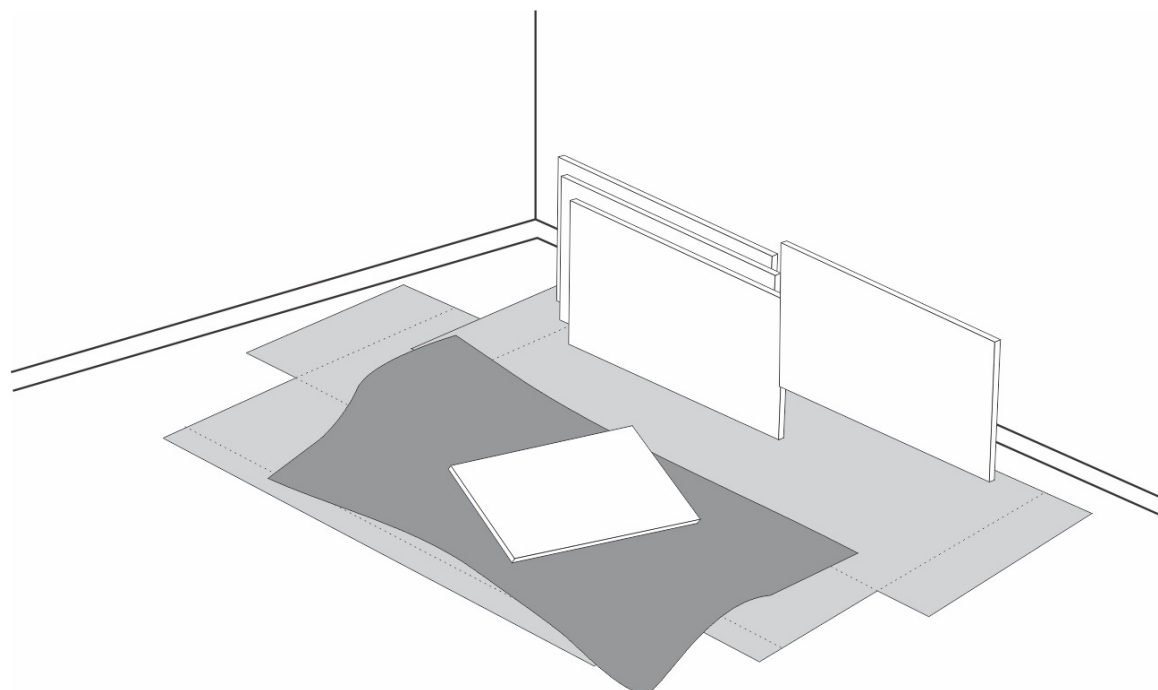

*Image 01 Peças separadas / Separate the parts / Piezas separadas

*** Antes de iniciar a montagem, verifique todos os componentes com a lista de peças, separe os acessórios por tipo e montar o móvel deitado.**

*Before beginning the assembly check all components with the parts list, separate hardware by type and assemble the furniture lying down.

*Antes de comenzar el montaje compruebe todos los componentes con la lista de piezas, separe los herrajes por tipo e montar el móvil acostado.

*** As peças vêm com o código estampado.**

* The parts come with their code stamped on.

* Los códigos de las piezas están sellados en las mismas.

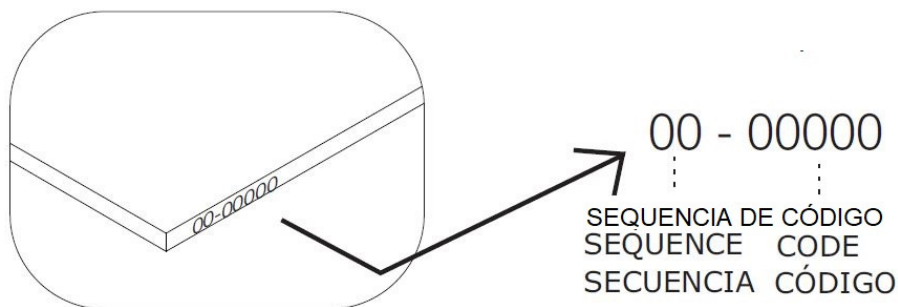

Ferramentas / Tools / Herramientas

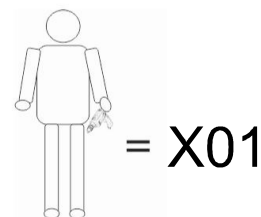
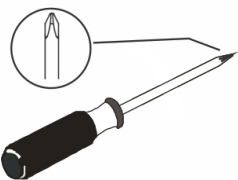

Acessórios / Hardware / Accesorios



Ⓐ = X16



Ⓑ = X3



Ⓒ = X3

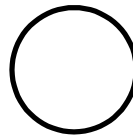

Ⓓ = X3



Ⓔ = X3



Ⓕ = X16

| SEQUENCIA / SECUENCIA / SEQUENCIA | CÓDIGO/CÓDIGO/CODE | DESCRIÇÃO / DESCRIPCIÓN / DESCRIPTION | QUANTIDADE / CANTIDAD / QTY |
|-----------------------------------|--------------------|--|-----------------------------|
| 01 | 50964 | BASE INFERIOR/LOWER BASE | 1 |
| 02 | 50966 | LATERAL ESQUERDA/LATERAL IZQUIERDA/LEFT SIDE | 1 |
| 03 | 50968 | FUNDO/FONDO/BOTTOM | 1 |
| 04 | 50967 | LATERAL E DIVISÓRIA/LATERAL Y PARTICIÓN/SIDE AND PARTITION | 2 |
| 05 | 50965 | TAMPO/CUBIERTA/TOP | 1 |
| 06 | MET0121 | SUPORTE PARA PÉS/APOYO AL PIE/FOOT SUPPORT | 4 |
| 07 | PES0371 | PÉ CILINDRICO/PIE CILINDRICO/CYLINDRICAL FOOT | 4 |

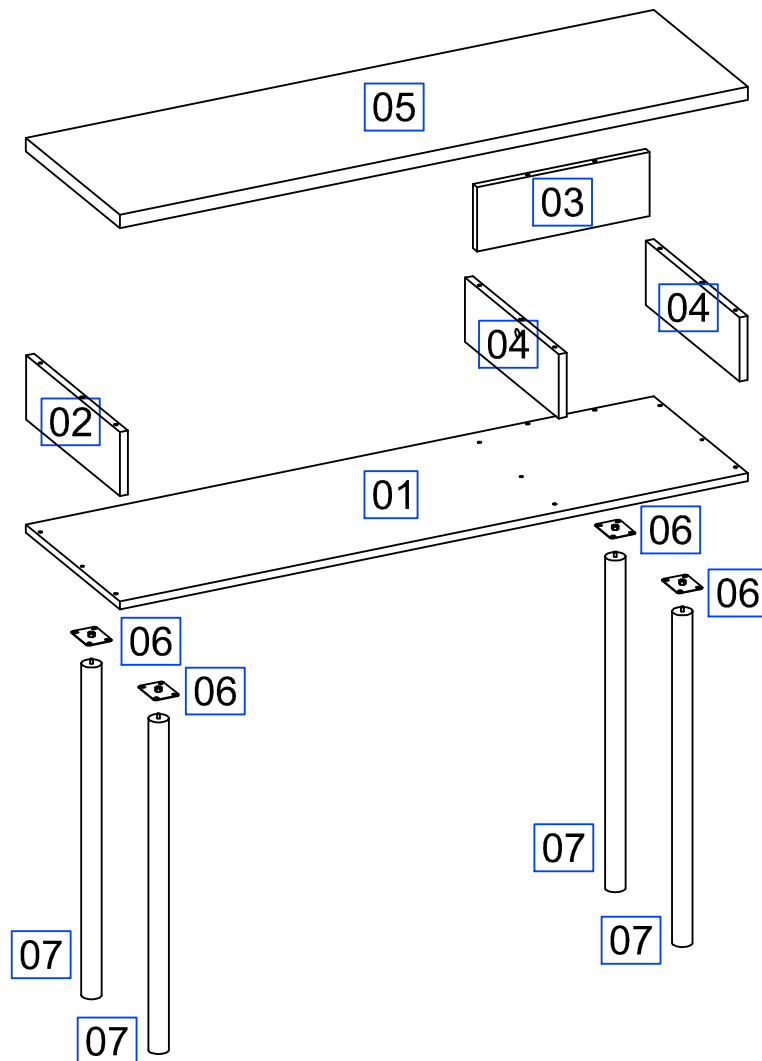

*** Antes de começar, você precisa saber:**

* Before starting, you have to know:

* Antes de empezar, necesitas saber:

() **Você deve sempre fixar o pino até o final usando um martelo de borracha.**

You should always fix the dowel until the end using a rubber hammer.

Deves siempre fijar ese accesorio hasta el final usando un martillo de caucho

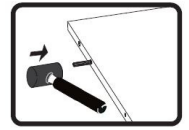

() **Você deve parafusar o acessório usando uma parafusadeira ou uma chave de fenda phillips Furo de 0,236 polegadas (o furo menor).**

You must screw thi hardware using an eletric drilling machine or phillips screwdriver only in the 0,236 inches hole (the smaller hole).

Deves siempre fijar ese accesorio usando un taladrador eléctrico o llave Phillips solamente en el agujero de 6mm.

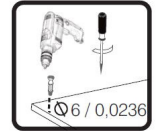

() **Sempre conserte este acessórios com a flecha voltada para o buraco.**

Always fix this hardware with the arrow faced to the hole.

Deves siempre fijar ese accesorio con la seta hacia el agujero

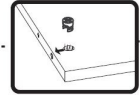

PASSO / STEP / PASO 01

*** Encaixe os acessórios "A" no extremidades das peças "C" no faces.**

* Insert hardware "A" on the extremities of the part 04 and hardware "C" on the face of it.

* Encaja los accesorios "A" en los extremos de las piezas "C" en las caras.

X2

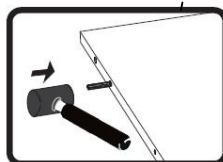
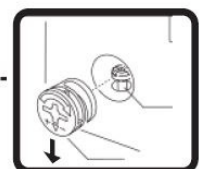
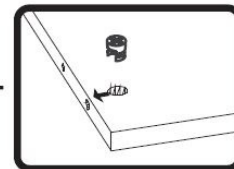
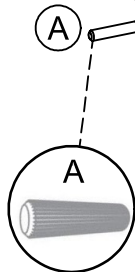
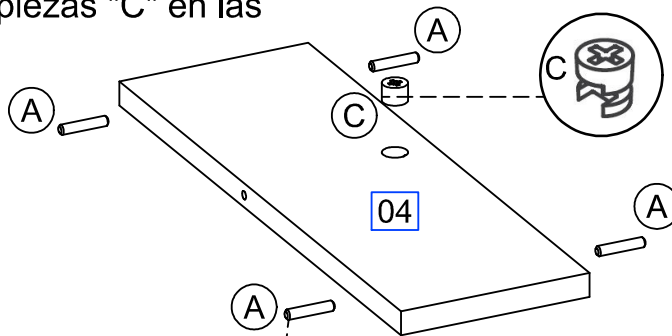

*** Inserir com o cogumelo para o buraco de acordo com a imagem.**

* Be aware the arrow of the nuts must be faced according to the image.

* Inserir con la seta hacia el agujero de acuerdo a la image.

PASSO / STEP / PASO 02

*** Encaixe os acessórios "A" no faces.**

* Insert accessorie "A" into the extremity of part 03.

* Encaja los accesorios "A" en las caras.

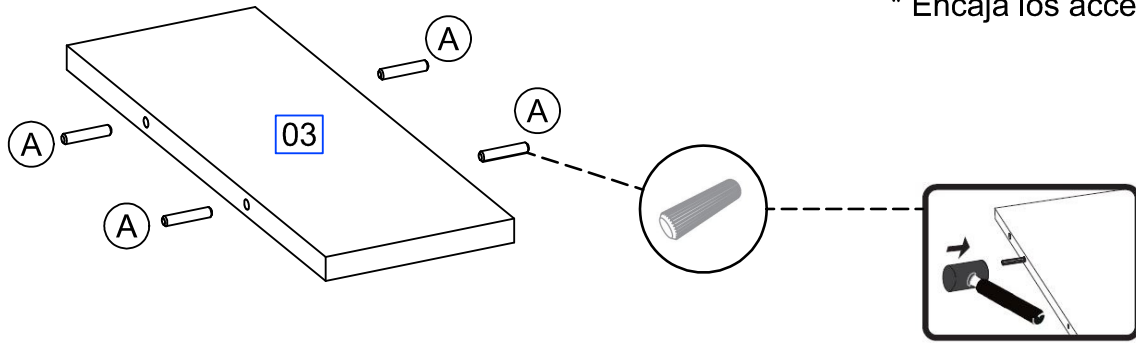

PASSO / STEP / PASO 03

*** Encaixe os acessórios "A" no extremidades das peças "C" no faces.**

* Insert hardware "A" on the extremities of the part 02 and hardware "C" on the face of it.

* Encaja los accesorios "A" en los extremos de las piezas "C" en las caras.

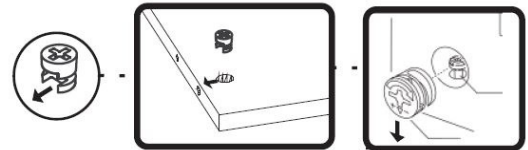
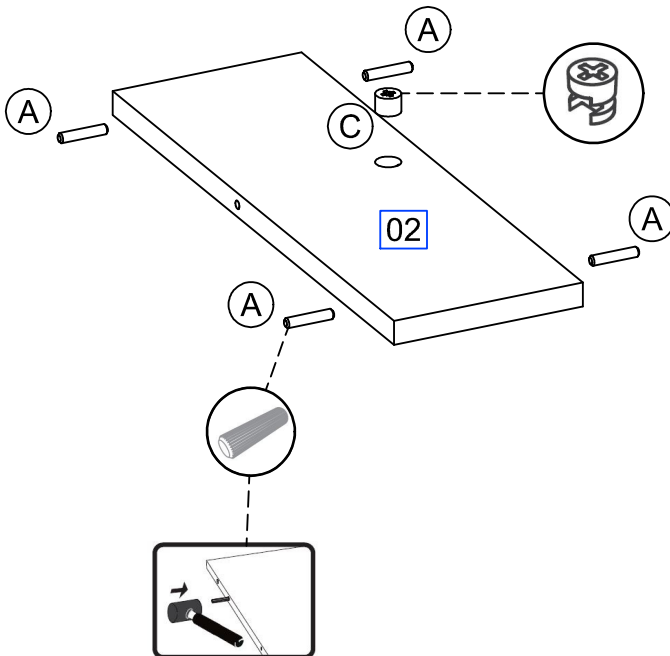

*** Inserir com o cogumelo para o buraco de acordo com a imagem.**

* Be aware the arrow of the nut must be faced according to the image.

* Inserir con la seta hacia el agujero de acuerdo a la image.

STEP / PASO 04

*** Encaixe os acessórios "B" no faces.**

* Insert hardware "B" on the surface of part 05.

* Encaja los accesorios "B" en las caras.

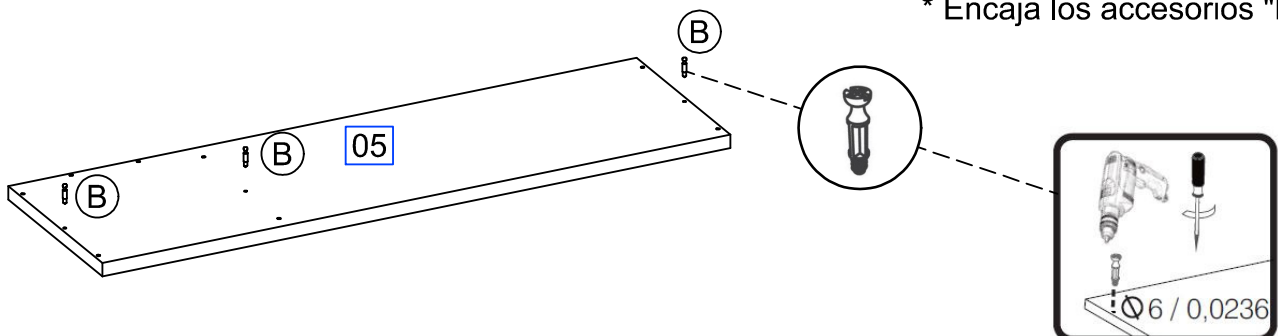

STEP / PASO 05

*** Peça de engate 02, parafuso usando Acessório "E".**

* Attach part 02 to the part 01 according to the image, then screw it using hardware "E".

* Enganche pieza 02, atornillar usando el accesorio "E".

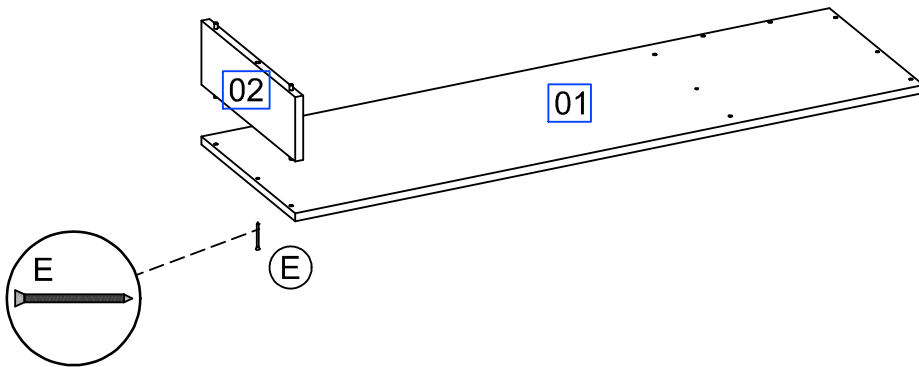

STEP / PASO 06

*** Engate parte 03, acordo mostradores existentes peça 01.**

* Attach part 03 according to the existing pre holes of part 01.

* Enganche pieza 03, acuerdo las marcas existentes en el pieza 01.

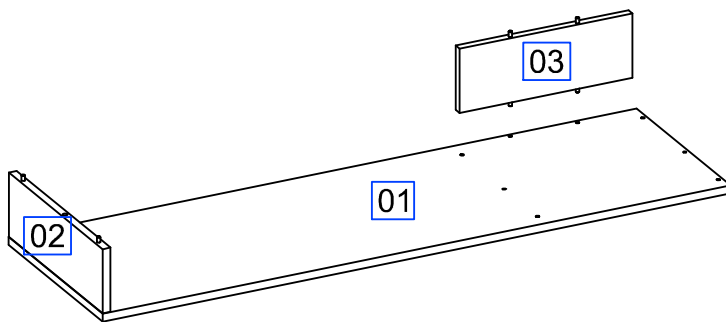

STEP / PASO 07

*** Peça de engate 04, parafuso usando Acessório "E".**

* Attach part 04 to the part 01 according to the image, then screw it using hardware "E".

* Enganche pieza 04, atornillar usando el accesorio "E".

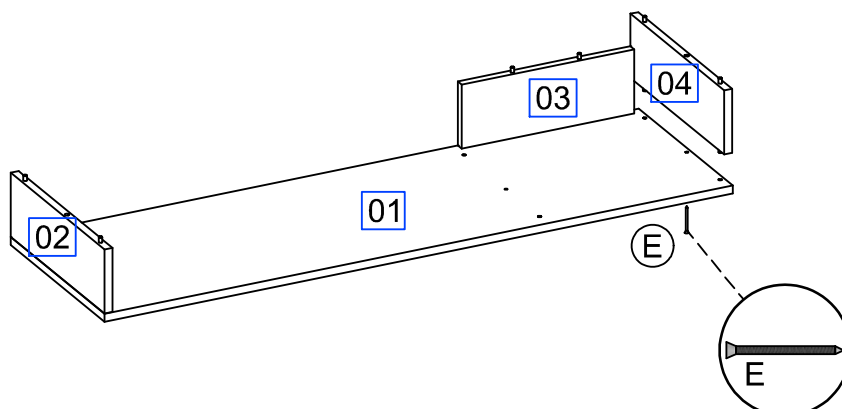

PASSO / STEP / PASO 08

*** Anexe a parte 04 ao parte 01 de acordo com a imagem, então aperte ele usando o acessório "E".**

* Attach part 04 to the part 01 according to the image, then screw it using hardware "E".

* Enganche pieza 04, atornillar usando el accesorio "E".

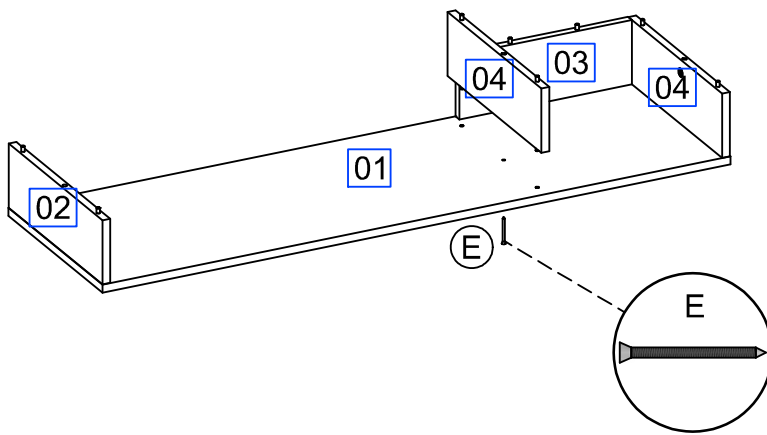

PASSO / STEP / PASO 09

*** Anexe a parte 05 às partes 02 e 04 de acordo com o imagem. Então aperte-os usando as porcas "C".**

* Attach part 05 to the parts 02 and 04 according to the image. Then screw them using the nuts "C".

* Enganche pieza 05 en la piezas 02 y 04. Atonillar las tuercas.

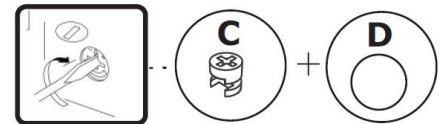
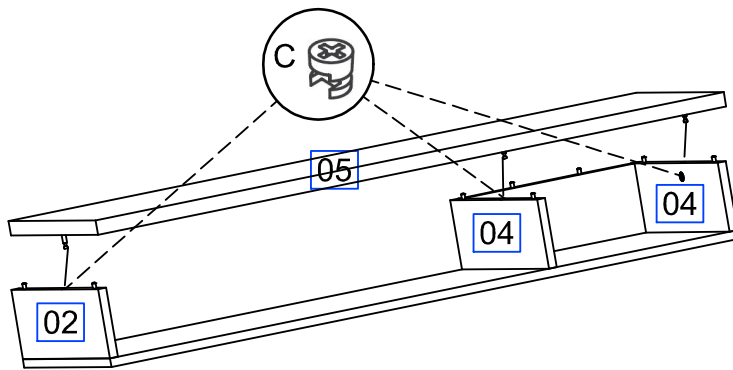

PASSO / STEP / PASO 10

*** Aparafusar a peça 06, usando o acessório "F" de acordo aos pré-buracos existentes de parte 01.**

* Screw the part 06, using the hardware "F" according to the existing pre holes of part 01.

* Fijar pieza "06", usando accesorios "F", acuerdo las marcaciones existentes en el pieza.

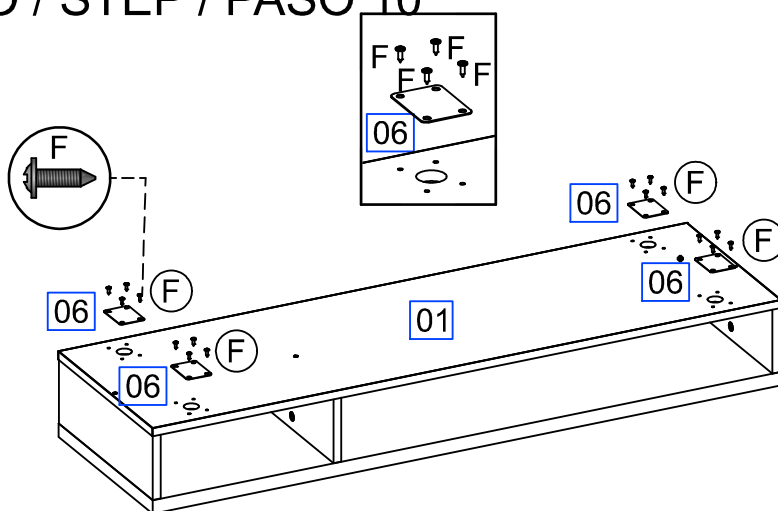

PASSO / STEP / PASO 11

*** Anexe a parte 07 à peça 06 de acordo com a imagem.**

* Attach part 07 to the part 06 according to the image.

* Enganche pieza 07 en la pieza 06, acuerdo con la imagen.

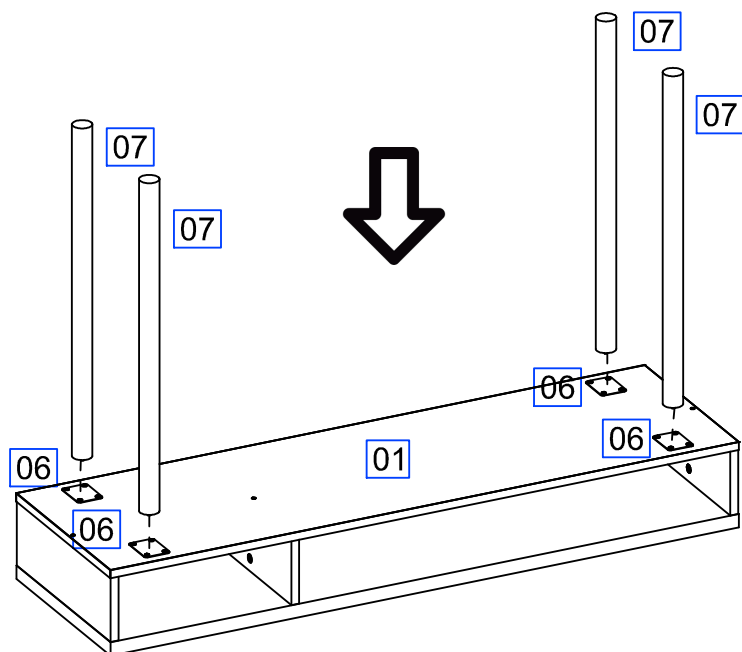

ASPECTO FINAL / FINAL VIEW

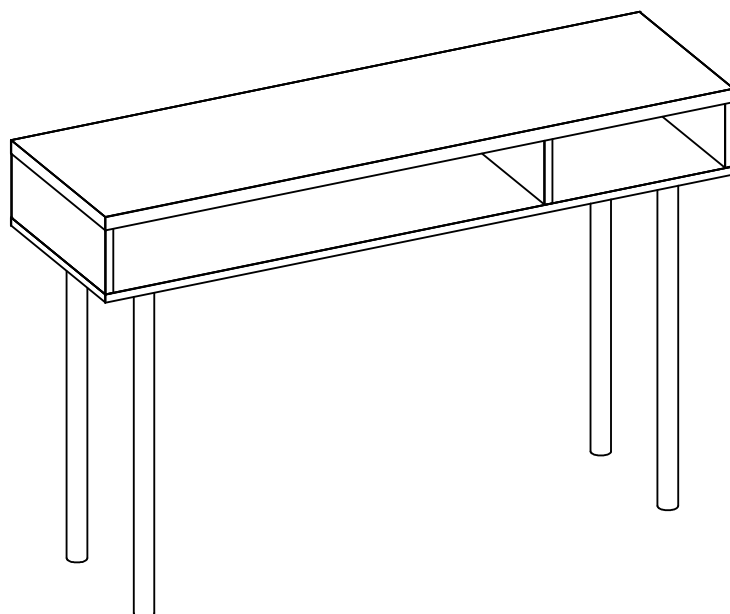

WARNING

ATENCIÓN

TIPOVER SYSTEM

SISTEMA ANTI-VUELCO

Please attach the hardware (Z1) using screw (Z2) in the part 01, according to the image. Then, drill the wall to press the wings (Z3) into the hole.

Por favor enganche el accesorio (Z1) usando el tornillo (Z2) en la pieza 01, acuerdo la image.

Entonces, perfora la pared para poner los tacos (Z3) en el agujero

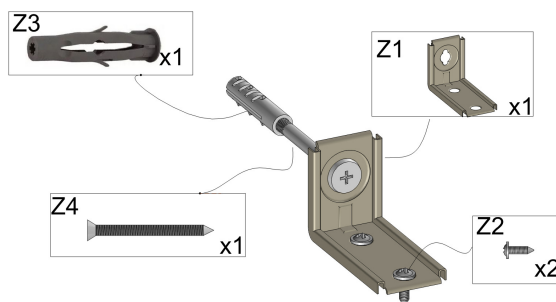
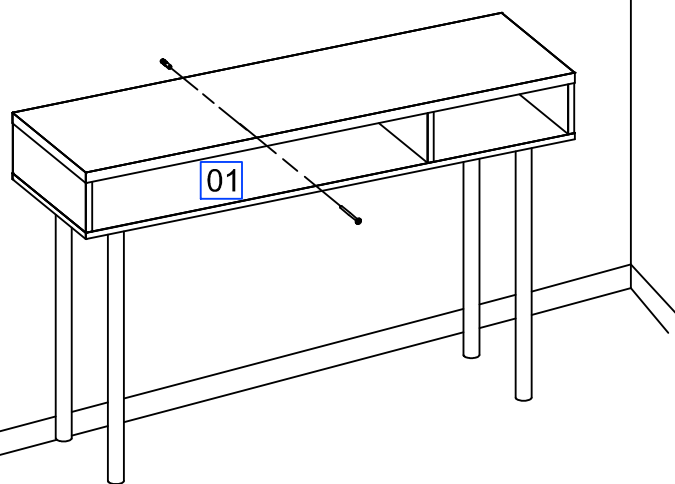
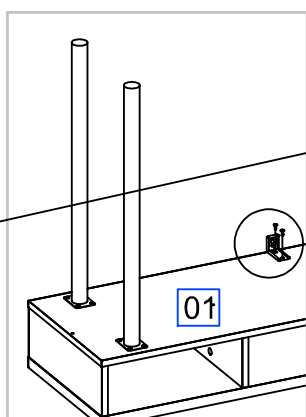

Hardware (Z3) plugged in the wall

Acesorio (Z3) fijado en la pared

Now fix entertainment unit into the wall with hardware (Z1) and Screw (Z4)

Ahora fija tu centro de entretenimiento e la pared con el accesorio (Z1) y tornillo (Z4)

PESO / WEIGHT / PESO

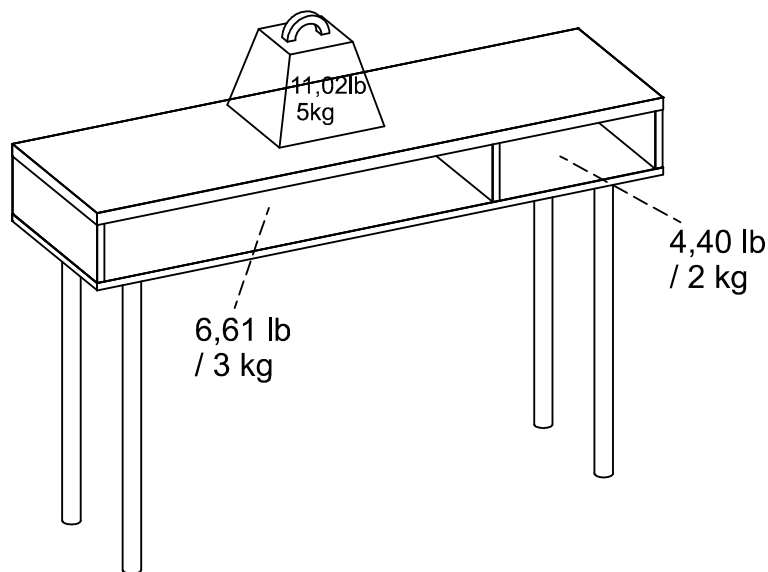
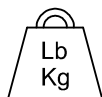

*** Esteja ciente sobre o máximo pesos mostrados na montagem instrução.**

* Be aware about maximum weights shown in the assembly instruction.

* Todos los pesos máximos indicados en el manual deben ser respetados.

EVITAR ACIDENTES / AVOID ACCIDENTS / PREVENIR ACCIDENTES

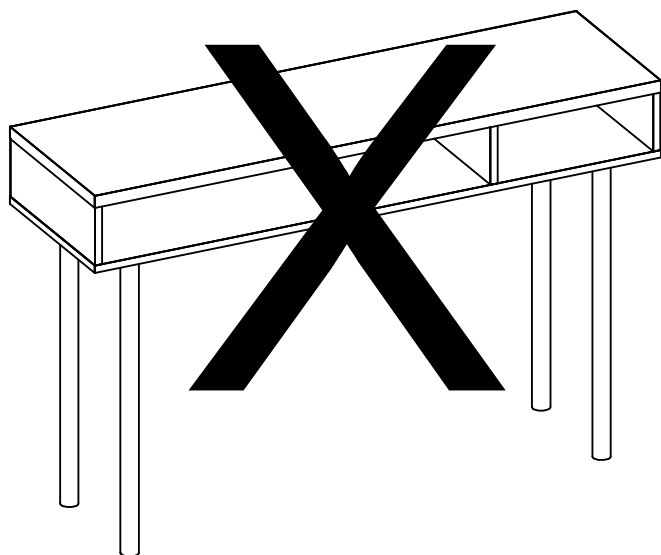

*** Não suba ou incline-se sobre a mobília.**

* Don't climb or lean on the furniture.

* No se suba ni se apoye en el mueble.

MANUTENÇÃO E LIMPEZA

MAINTENANCE AND CLEANING / MANTENIMIENTO Y LIMPIEZA

*** Para limpeza use apenas um pano levemente umedecido em água.**

* For cleaning use only cloth slightly dampened in water.

* Para la limpieza utilice sólo un paño húmedo con agua.