



# APARADOR RETRÔ METAL ÔNIX

## ATENÇÃO/ ATTENTION / ATENCION

VÍDEO DE MONTAGEM DISPONÍVEL NO SITE / ASSEMBLY VIDEO AVAILABLE ON THE SITE  
VÍDEO DE MONTAJE DISPONIBLE EN EL SITIO

[www.olivar.com.br](http://www.olivar.com.br)

DIMENSÕES DO PRODUTO / PRODUCT DIMENSIONS / DIMENSIONS PRODUCT - WxDxH / LxDxA - 800 X 403 X 829 MM

**ATENÇÃO/ ATENCION/ ATTENTION**  
ESTE PRODUTO NÃO PODE SER ARRASTADO.  
THIS PRODUCT MUSTNOT BE DRAGGED.  
ESTE PRODUCTO NO SE PUEDE ARRASTRAR

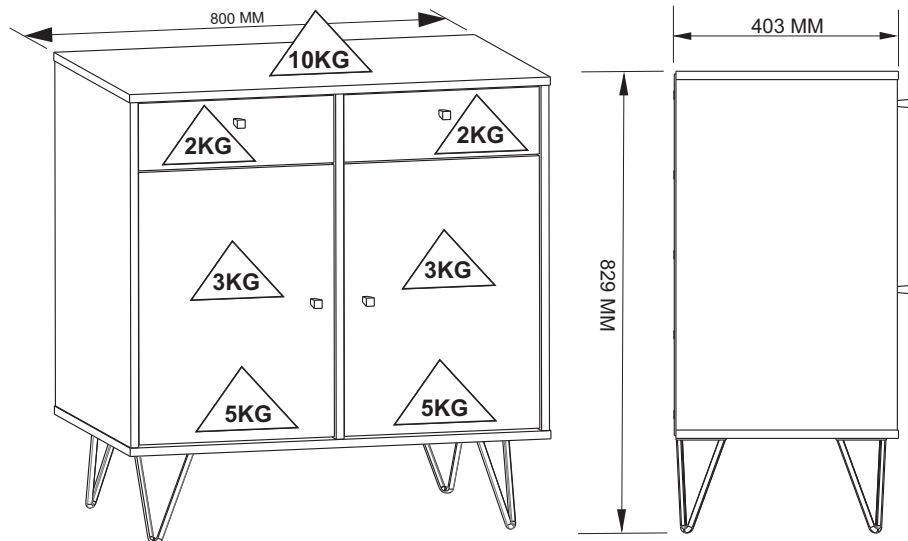

PEÇAS NUMERADAS/ NUMBERED PARTS/  
PIEZAS NUMERADAS

EX: 1915X-X 05(peça/ piece/ pieza number)

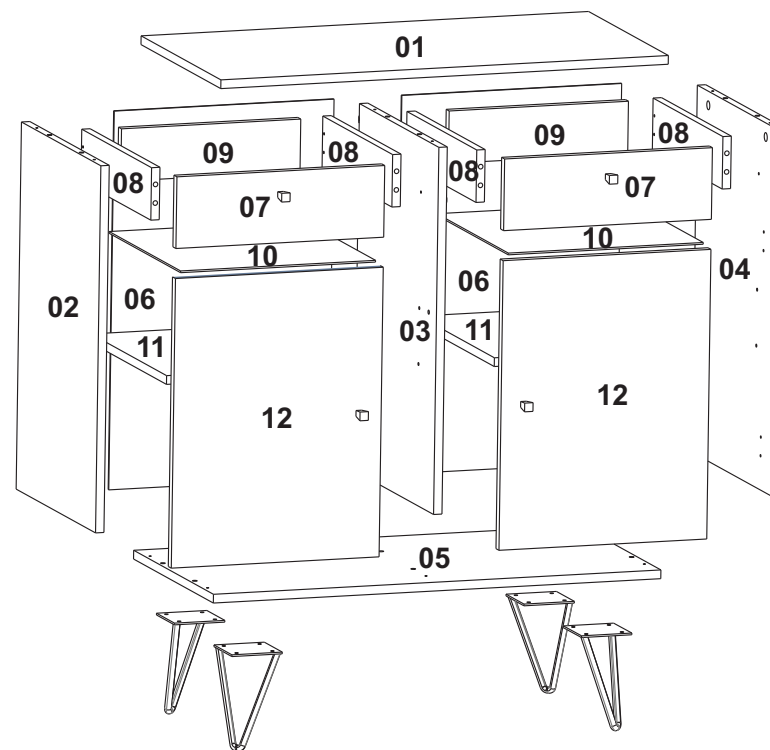

Vídeo de Montagem  
Assembly video  
Vídeo de Montaje

### CUIDADOS ESPECIAIS

**LIMPEZA-** Pano limpo umedecido em água e sabão neutro.  
**BRILHO-** Fanela seca.

### SPECIAL CARE

**CLEANING-** Clean cloth moistened with water and mild soap.  
**SHINE-** Dry cloth.

### CUIDADOS ESPECIALES:

**LIMPIEZA-** Paño limpio humedecido con agua y un jabón suave.  
**BRIGHT-** Fanela seco.

### ATENÇÃO / ATTENTION / ATENCION

Nunca utilizar óleos, lustra móveis; produtos abrasivos, saponáceos, esponja de aço e outros.

Never use oils, polish furniture , abrasive products, soaps, steel sponge and others.

Nunca use aceites, pulimentos; abrasivos, jabones, esponja de acero y otros.

MONTAR O PRODUTO SOBRE A EMBALAGEM, EVITANDO DANOS NA PINTURA. ACONSELHAMOS QUE A MONTAGEM DO PRODUTO SEJA POR UM PROFISSIONAL.

SETUP THE PRODUCT ON TOP OF THE PACKAGING, AVOIDING DAMAGE TO THE PAINT. WE RECOMMEND THAT THE INSTALLATION IS DONE BY A PROFESSIONAL.

MONTAR EL PRODUCTO EN EL PAQUETE, EVITAR LESIONES EN PINTURA. AVISAMOS QUE EL MONTAJE DEL PRODUCTO SEA UN PROFESIONAL.



Ferramentas necessárias / Necessary tools / Herramientas Necesarias  
(não fornecidas) (not provided) (No proporcionadas)



1

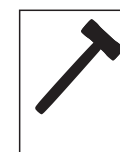
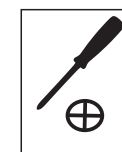

**MEDIDA UTILIZADA EM MM /  
UNIT MEASURE USED IS MILLIMETERS (MM)**

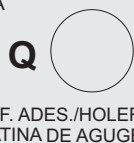
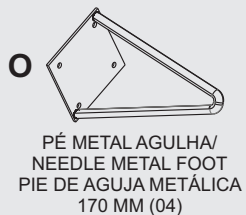
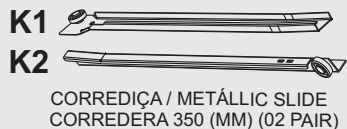
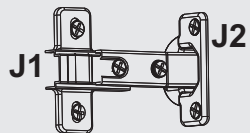
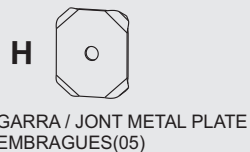
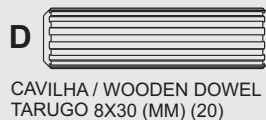

ITEM		DESCRIÇÃO DA PEÇAS / DESCRIPTION OF PARTS / UNIT MEASURE USED IS MILLIMETERS (MM)				CORES / COLORS / COLORES		
CÓDIGO CODE	Nº	NOME/NAME/NOMBRE	MEDIDAS / MEASURES (MM)	TIPO TYPE	QUANT AMOUNT CANTIDAD	BCO WHITE BLANCO	PRETO BLACK NEGRO	MEL FREIJÓ
14263	01	TAMPO/ TOP	800X400X15	MDP	01	01/05	01/07	01/18
13945	02	LATERAL ESQUERDA/ LEFT SIDE/ LADO IZQUIERDO	630X398X15	MDP	01	02/05	02/07	02/18
13946	03	DIVISOR/ DIVIDER	630X398X15	MDP	01	03/05	03/07	03/08
13947	04	LATERAL DIREITA/ RIGHT SIDE/ LADO DERECHO	630X398X15	MDP	01	04/05	04/07	04/18
14264	05	BASE	800X400X15	MDP	01	05/05	05/07	05/18
13948	06	FUNDO TRÁS / BACK / TRASEIRO	650X393X03	TRI	02	06/05	06/07	06/18
13949	07	FRENTE GAV ESQ DIR/ FRONT LEFT DRAWER RIGH/ CÁJON DELANTERO IZQUIERDO DERECHO	371X123X15	MDP	02	07/05	07/07	07/18
13950	08	LAT.GAV/ LEFT SIDE/ LAD. CAJON	350X90X15	MDP	04	08/05	08/07	08/18
13951	09	CONT. FRENT. GAV./AGAINST DRAWER FRONT/ CONTRA EL FRENTE DEL CAJÓN	320X90X15	MDP	02	09/05	09/07	09/18
13952	10	FUNDO GAV./ DRAWER BACKGROUND/ FONDO CÁJON	358X348X03	TRI	02	10/05	10/07	10/18
13953	11	PRATELEIRA / SHELF/ ESTANTE	373X368X15	MDP	02	11/05	11/07	11/18
13954	12	PORTA ESQ/ DIR/ LEFT RIGHT DOOR/ PUERTA IZQ. DER	497X371X15	MDP	02	12/05	12/07	12/18
438	A	PF. / Screw / Tornillo 4,0x40(MM) CH			14			
8233	B	PF./ Screw/ Tornillo 3,5x25(MM)FL			04			
986	C	PF./ Screw/ Tornillo 3,5x14(MM) CRR			78			
137	D	Cavilha / Wooden Dowel / Tarugo 8x30(MM)			20			
532	E	Pino Minifix / Minifix Screw 32(MM)			06			
508	F	Tambor Minifix / Minifix Round Nut 15(MM)			06			
509	G	Tampa Minifix / Minifix Cover Cap 15(MM)			06	BCO		
7125							PTO	
911	H	Garra/ Jont Metal Plate/ Embragues			05			
248	I	Prego / Nail / Clavo 8x8(MM)			40			
145	J	Dobradiça Caneco Calço 12MM/Hinge/ Bisagra(04)			04			
139	K	Corred./Metallic Slid 350(MM) (02 Pair)			02			
3441	L	Amortecedor/ Pu Bumber/ Parachoques			02			
15175	M	Cantoneira PL/Plast. corner with lid / Esquina PL. 20X20X42(MM)			04	CINZA	CINZA	CINZA
13931	N	Puxador PL/ Handle/ Manija 27x15x10 MM			04	COBRE	COBRE	
13932								PTO
13790	O	Pé Metal Agulha/ Needle Metal Foot/ Pie de Aguja Matálica 170mm			04	COBRE	COBRE	
13927								PTO
12735	P	Suporte Pl / Support PL			18	BCO		
13362							PTO	
339								CAFÉ
13879	Q	Tapa F. Ades./Holer Sticker/Pegatina de Agugero 18 mm (FREIJÓ)			06			FREIJÓ
		Certif. de Garant. / Warranty Certif.			01			

**FIXAR PINO DE MINIFIX, TAMBOR E TAMPA / FIXING THE MINIFIX PIN, DRUM AND MINIFIX COVER  
COLOQUE EL PINO E TAMBOR MINIFIX Y LA TAMPA**

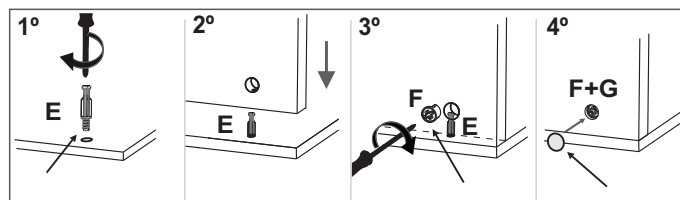

# PREPARAÇÃO DE PEÇAS/ PARTS PREPARATION / PREPARACION DE PIEZAS

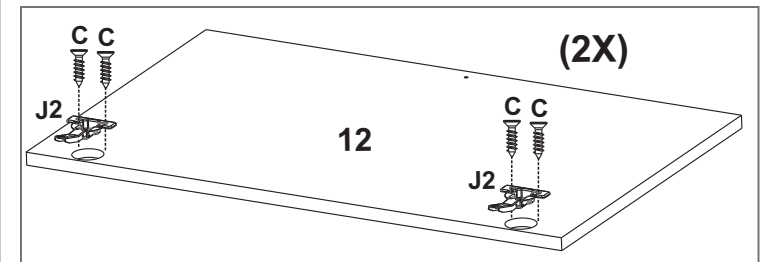
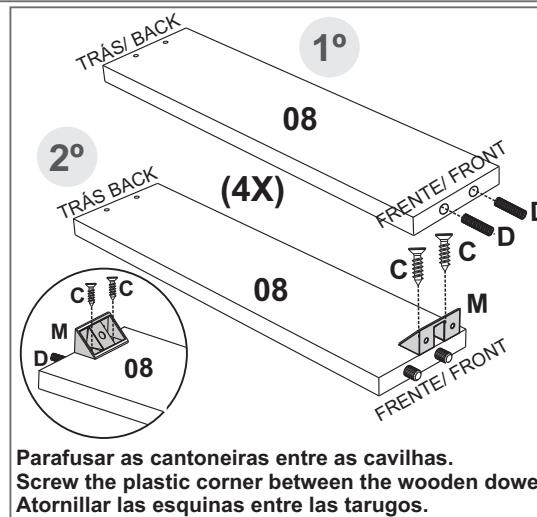
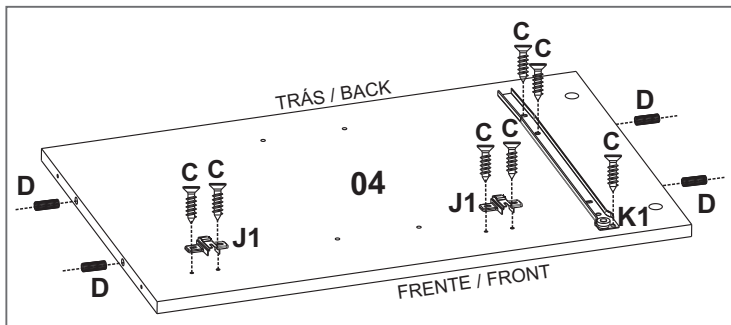
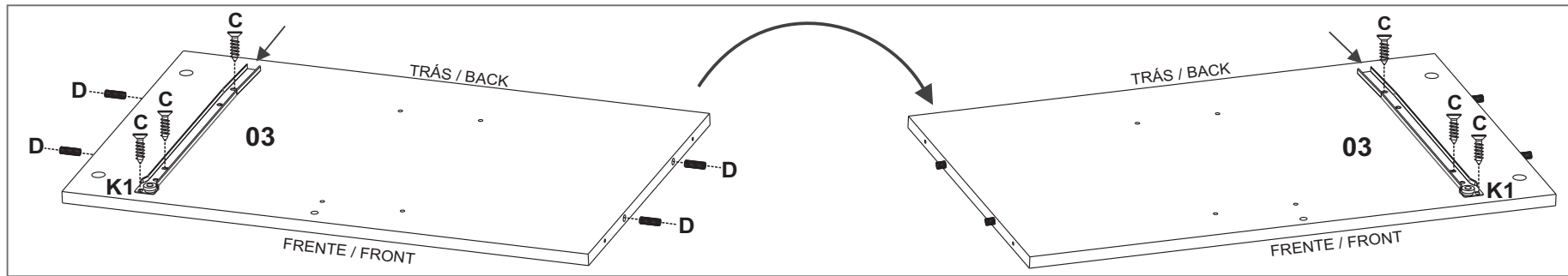
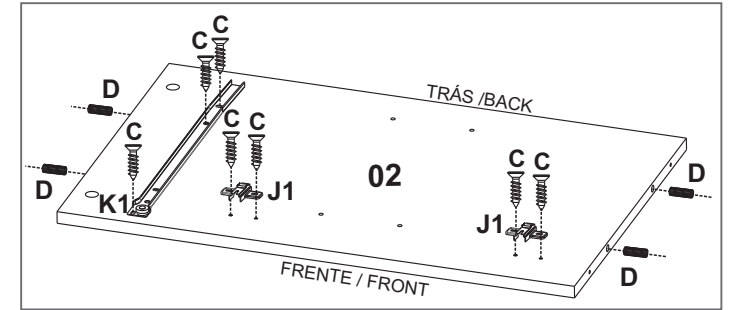
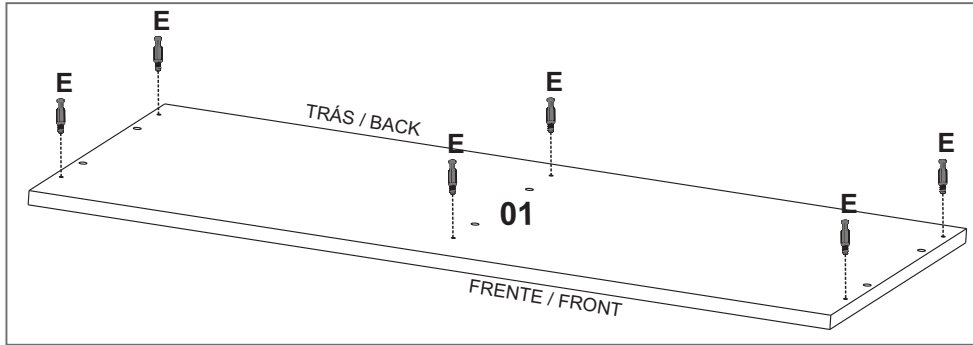
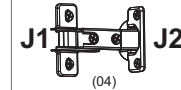
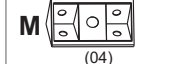
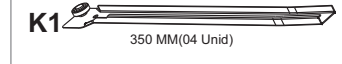
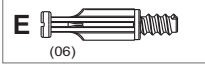
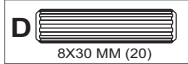
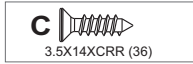

**1** Obs: As peças pintadas nos passos são apenas ilustrativas.  
The parts painted in the steps are illustrative only.  
Las partes pintadas en los pasos son solo ilustrativas.

 Borda colorida fica na frente.  
Colored edge is forward.  
El borde de color está hacia adelante

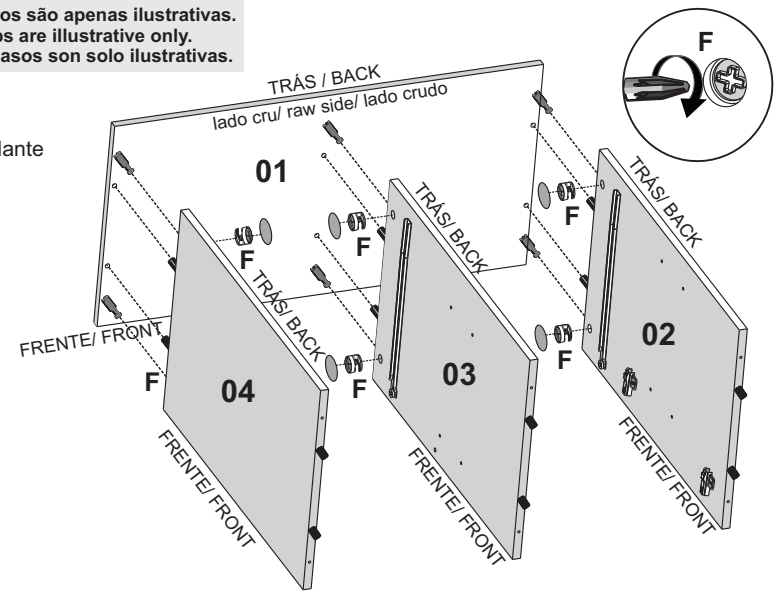
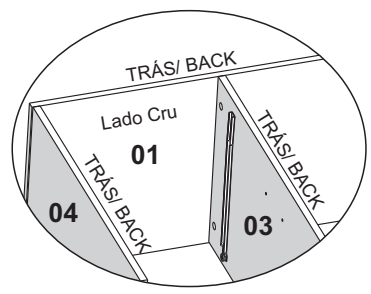

**F=06**  
**G ou Q=06**



**2**

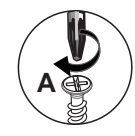

**A=06**

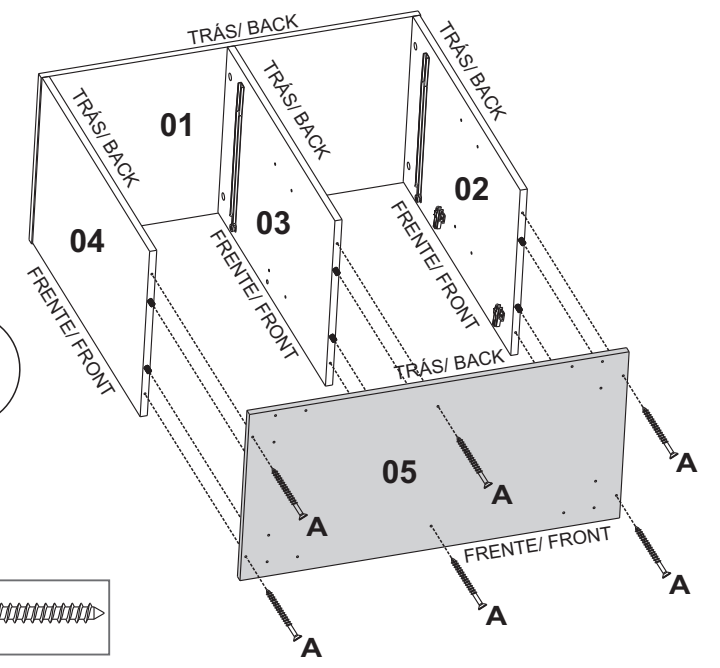
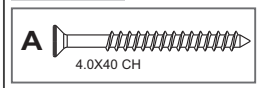

**3**



**H=05**  
**I=40**

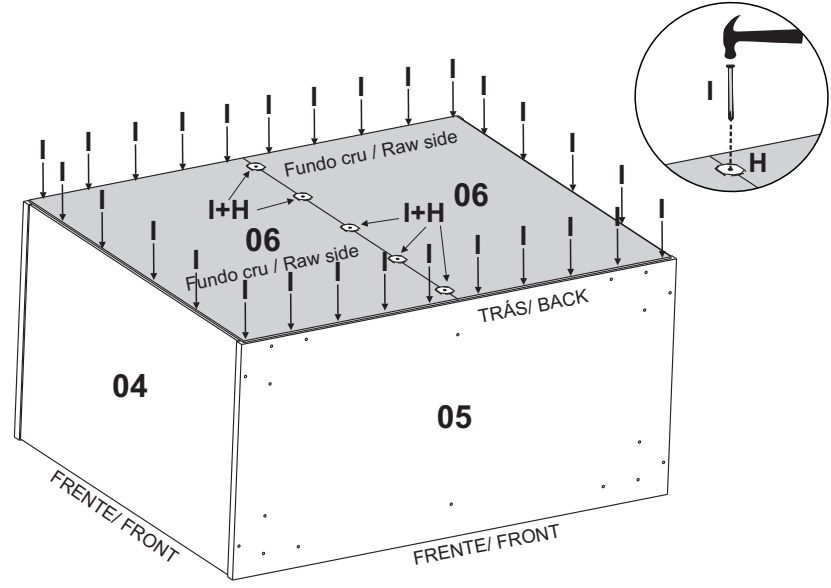
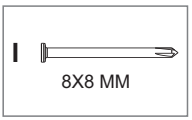
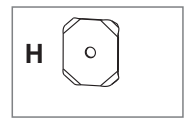

**4**



**C=16**  
**O=04**

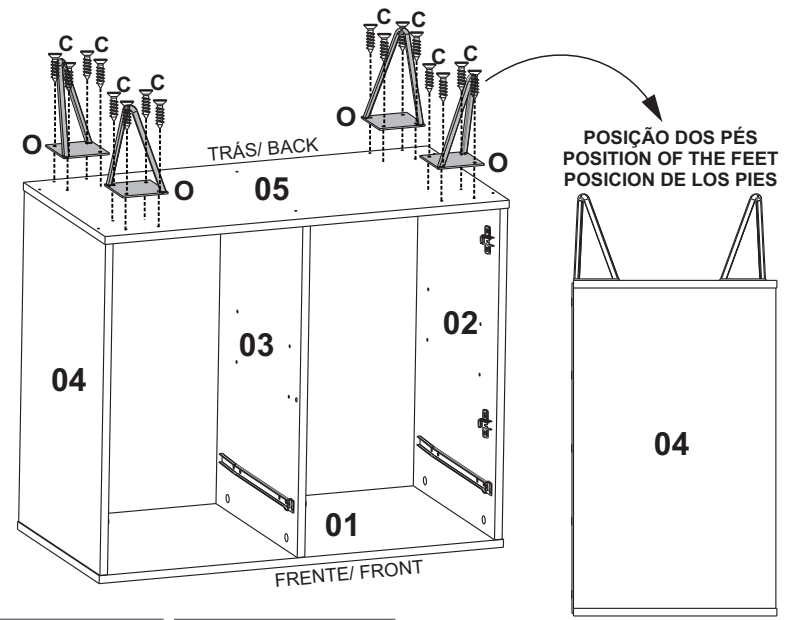
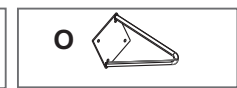
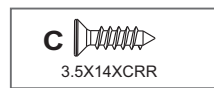

**5** MONTAGEM GAVETA / ASSEMBLY OF THE DRAWER / MONTAJE LE CÁJON

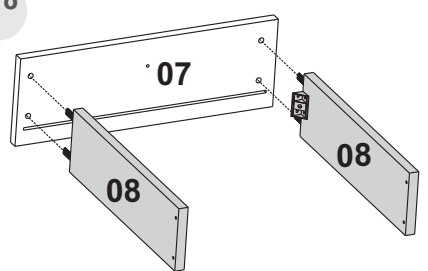
**1º** 

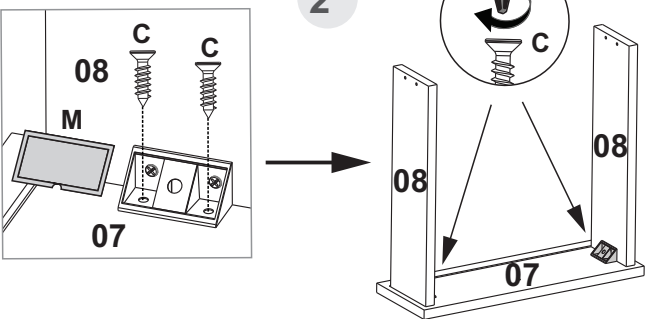
**2º** 

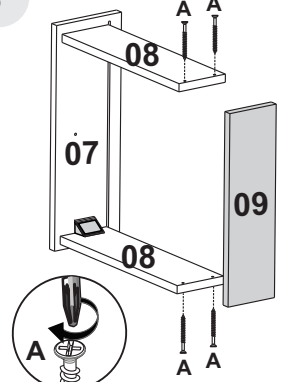
**3º** 

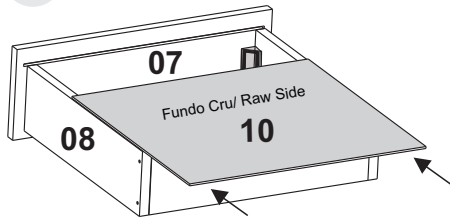
**4º** 

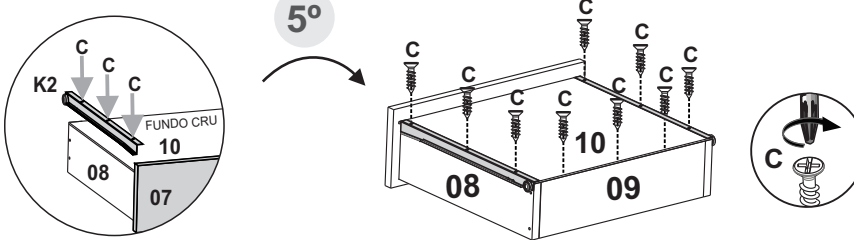
**5º** 

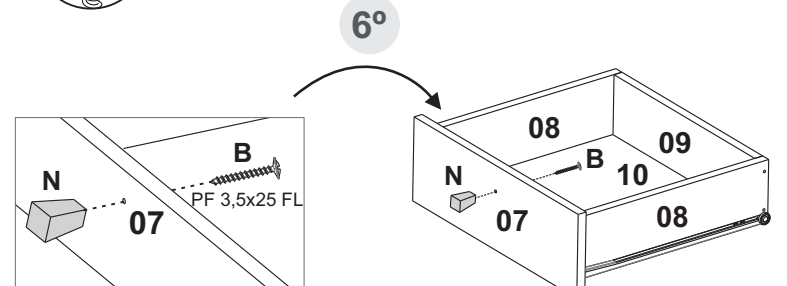
**6º** 

**A=08**  
**B=02**  
**C=26**  
**K2=04**  
**M=04**  
**N=02**

**A** 4.0X40 CH  
**B** 3,5x25 FL  
**C** 3,5X14XCRR  
**K2** 350 MM  
**M**  
**N**

**FUNDO CRU / Raw Side** 10

**PF 3,5x25 FL**

**6**

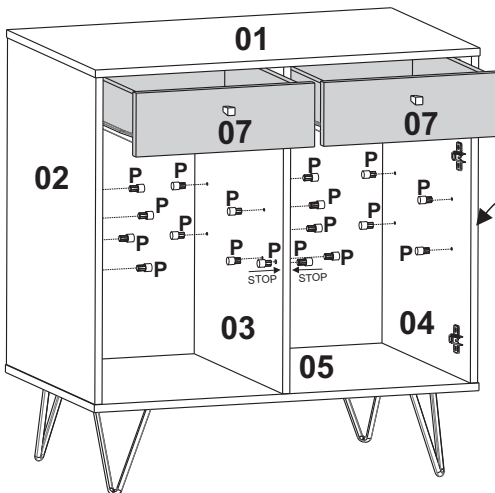

**P=18**

**P**

**!**

**P**

Martelo de borracha  
 Rubber hammer  
 Martillo de goma

**7**

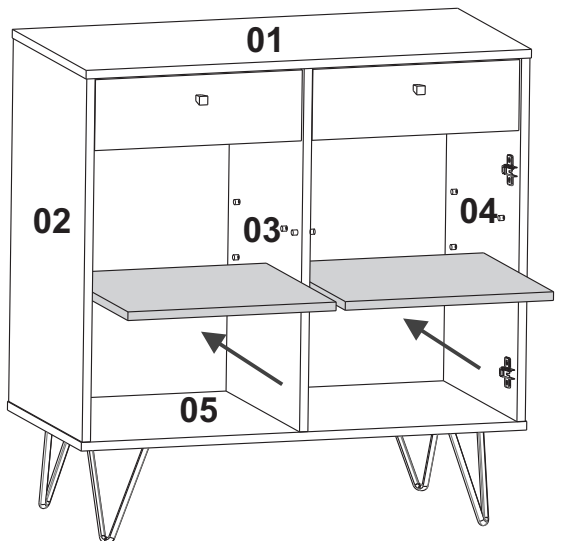

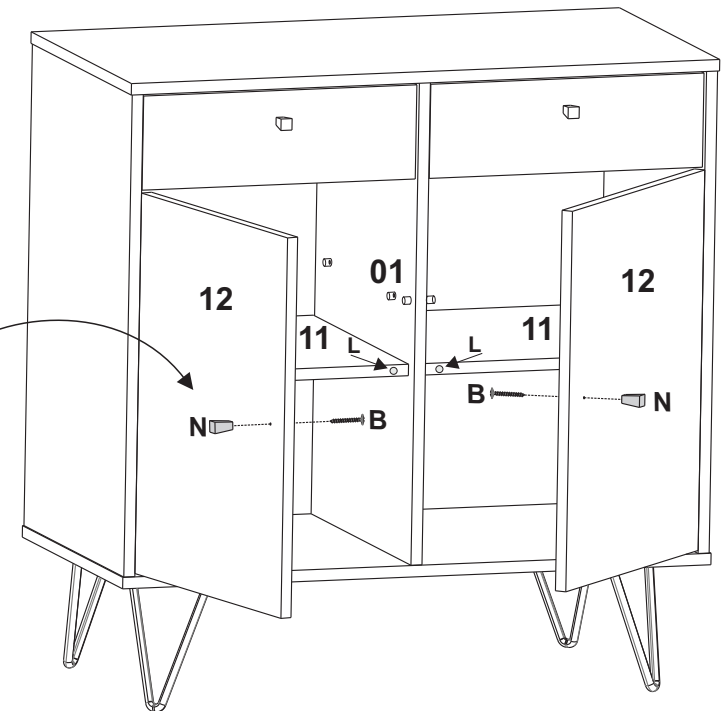
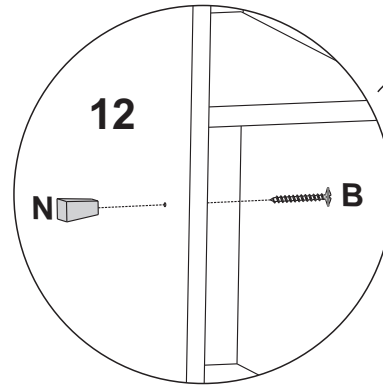
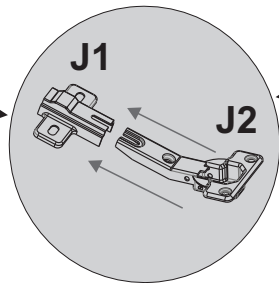
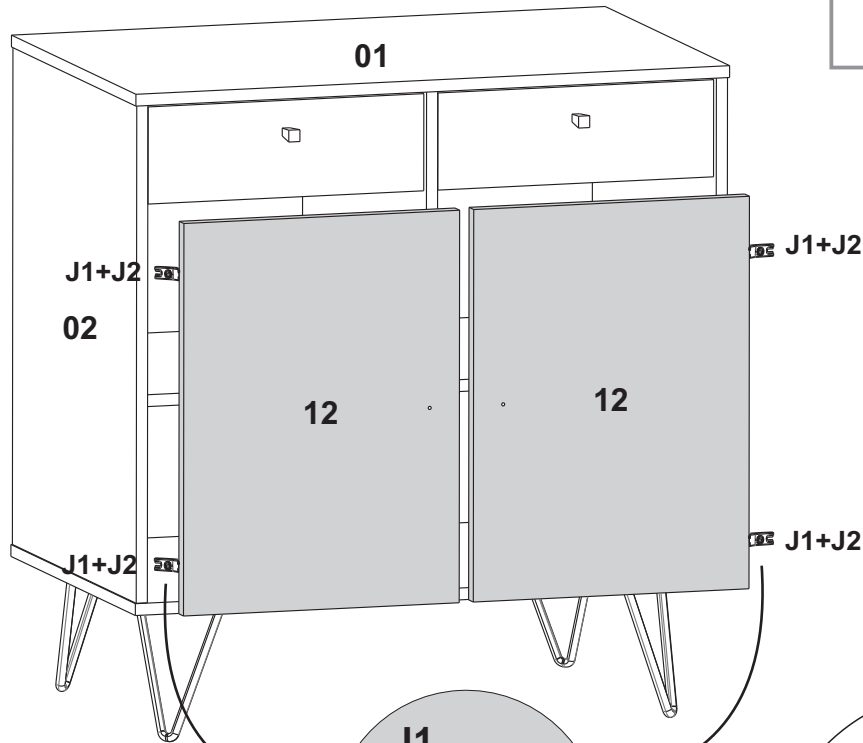
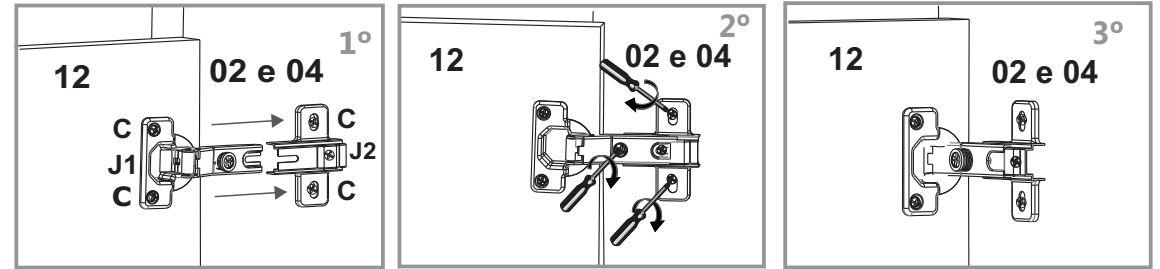

**B=02**  
**L=02**  
**N=02**

