

DIMENSÕES DO PRODUTO / PRODUCT DIMENSIONS / DIMENSIONS PRODUCT - WxDxH / LxDxA - 800 X 403X 763 MM

ATENÇÃO/ ATENCION/ ATTENTION

ESTE PRODUTO NÃO PODE SER ARRASTADO.
THIS PRODUCT MUST NOT BE DRAGGED.
ESTE PRODUCTO NO SE PUEDE ARRASTRAR.

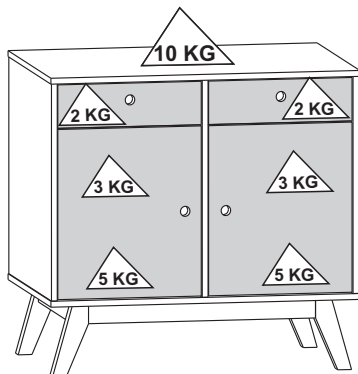

PEÇAS NUMERADAS/ NUMBERED PARTS/ PIEZAS NUMERADAS

EX: 1915X-X 05 (peça/ piece/ pieza number)

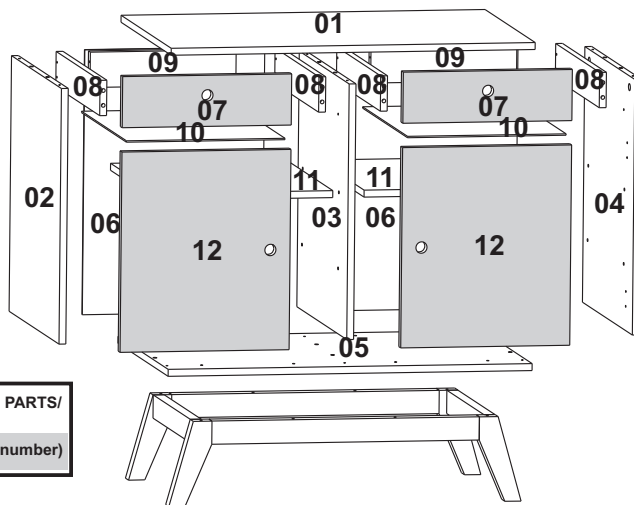

CUIDADOS ESPECIAIS
LIMPEZA- Pano limpo umedecido em água e sabão neutro.
BRILHO- Flanela seca.

SPECIAL CARE
CLEANING-Clean cloth moistened with water and mild soap.
SHINE- Dry cloth.

CUIDADOS ESPECIALES:
LIMPIEZA- Paño limpio humedecido con agua y un jabón suave.
BRIGHT- Flanela seco.

ATENÇÃO / ATTENTION / ATENCION
Nunca utilizar óleos, lustra móveis; produtos abrasivos, saponáceos, esponja de aço e outros.

Never use oils, polish furniture, abrasive products, soaps, steel sponge and others.

Nunca use aceites, pulimentos; abrasivos, jabones, esponja de acero y otros.

Ferramentas necessárias / Necessary tools / Herramientas Necesarias
(não fornecidas) (not provided) (No proporcionadas)



MONTAR O PRODUTO SOBRE A EMBALAGEM, EVITANDO DANOS NA PINTURA. ACONSELHAMOS QUE A MONTAGEM DO PRODUTO SEJA POR UM PROFISSIONAL.

SETUP THE PRODUCT ON TOP OF THE PACKAGING, AVOIDING DAMAGE TO THE PAINT. WE RECOMMEND THAT THE INSTALLATION IS DONE BY A PROFESSIONAL.

MONTAR EL PRODUCTO EN EL PAQUETE, EVITAR LESIONES EN PINTURA. AVISAMOS QUE EL MONTAJE DEL PRODUCTO SEA UN PROFESIONAL.

MEDIDA UTILIZADA EM MM / UNIT MEASURE USED IS MILLIMETERS (MM)

A PF./ SCREW/ TORNILLO 5,0x50 CH (08)

B PF./ SCREW/ TORNILLO 4,0x40 CH (14)

C PF./ SCREW/ TORNILLO 3,5x14 CRR (76)

D CAVILHA / WOODEN DOWEL TARUGO 8X30 MM (40)

E PINO MINIFIX / MINI FIX SCREW 32 MM (06)

F TAMBOR MINIFIX / MINI FIX ROUND NUT 15 MM (06)

G SUPORTE PL-STOP/ PL SUPPORT (18)

H GARRA / JONT METAL PLATE EMBRAGUES(05)

I PREGO/NAIL/ CLAVO(40)

J DOBRAD. CANECO CALÇO 12MM/HINGE/ BISAGRA (04)

L CANTONEIRA/ PLASTIC CORNER/ ESQUINA PL 20X20X42 (MM) (04)

M TAPA F. ADES./ HOLER STIKER/ PEGATINA DE AGUGERO 18MM(08)

ITEM	DESCRIÇÃO DA PEÇAS / DESCRIPTION OF PARTS / UNIT MEASURE USED IS MILLIMETERS (MM)			CORES / COLORS / COLORES				
CÓDIGO CODE	Nº	NOME/NAME/NOMBRE	MEDIDAS / MEASURES (MM)	TIPO TYPE	QUANT AMOUNT CANTIDA	BCO WHITE BLANCO	OFF WHITE	PRETO BLACK NEGRO
15740	01	TAMPO/ TOP	800X400X15	MDP	01	01/05	01/06	01/07
15737	02	LATERAL ESQUERDA/ LEFT SIDE/ LADO IZQUIERDO	550X398X15	MDP	01	02/05	02/06	02/07
10739	03	DIVISOR/ DIVIDER	550X398X15	MDP	01	03/05	03/06	03/07
10738	04	LATERAL DIREITA/ RIGHT SIDE/ LADO DERECHO	550X398X15	MDP	01	04/05	04/06	04/07
15736	05	BASE	800X400X15	MDP	01	05/05	05/06	05/07
15744	06	FUNDO TRÁS ESQ. DIR. / BACK / TRASEIRO	570X393X3	TRI	02	06/05	06/06	06/07
15735	07	FRENTE GAV ESQ DIR/ FRONT LEFT DRAWER RIGTH/ CÁJON DELANTERO IZQUIERDO DERECHO	371X110X15	MDP	02	07/05	07/06	07/07
15742	08	LAT.GAV/ LEFT SIDE/ LAD. CAJON	350X76X15	MDP	04	08/05	08/06	08/07
15743	09	CONT. FRENT. GAV./AGAINST DRAWER FRONT/ CONTRA EL FRENTE DEL CAJÓN	320X76X15	MDP	02	09/05	09/06	09/07
15745	10	FUNDO GAV / DRAWER BACKGROUND/ FONDO CÁJON	358X348X3	TRI	02	10/05	10/06	10/07
15741	11	PRATEL. ESQ.DIR. MÓVEL/ SHELF/ ESTANTE	365X373X15	MDP	02	11/05	11/06	11/07
15673	12	PORTA ESQ/ DIR/ LEFT RIGHT DOOR/ PUERTA IZQ. DER	371X430X15	MDP	02	12/05	12/06	12/07
15704	A	PF./ Screw / Tornillo 5,0x50 CH			08			
438	B	PF./ Screw / Tornillo 4,0x40(MM) CH			14			
986	C	PF./ Screw/ Tornillo 3,5x14(MM) CRR			76			
137	D	Cavilha / Wooden Dowel / Tarugo 8x30(MM)			40			
532	E	Pino Minifix / Minifix Screw 32(MM)			06			
508	F	Tambor Minifix / Minifix Round Nut 15(MM)			06			
12735	G	Suporte Pl / Support PL			18	BCO	BCO	PTO
7266								
911	H	Garra/ Jont Metal Plate/ Embragues			05			
248	I	Prego / Nail / Clavo 8x8(MM)			40			
145	J	Dobradica Caneco Calço 12MM/Hinge/ Bisagra(04)			4			
139	K	Corredija/Metalic Slid 350(MM) (02 Pair)			2			
15175	L	Cantoneira PL/Plast. corner / Esquina PL 20X20X42(MM)			4	CINZA	CINZA	CINZA
12734						BCO		
13877	M	Tapa F. Ades./ Holer Sticker/ Pegatina de Agugero 18 mm			08		GELO	
13363								PTO
15706	N	Cantoneira Metal/ Metal corner/ Esquina del metal 50X30X2 MM			04			
15574	W	Vista p/Pé Pinus Lateral/ Side Foot View/ Vista Lado del pie- 22X50X298MM			02	MOG	MOG	MOG
15577	X	Pé Pinus CHASSI-Lado X / Chassis foot-side X / Pie del chasis- lado X-190MM			02	MOG	MOG	MOG
15578	Y	Pé Pinus CHASSI-Lado Y / Chassis foot-side Y / Pie del chasis-lado Y- 190MM			02	MOG	MOG	MOG
15570	Z	Vista p/Pé Pinus Frontal/ Front Foot View/ Vista Front del pie-22X50X588MM			02	MOG	MOG	MOG
		Certif. de Garant./ Warranty Certif.			01			

X PÉ/FOOT/PIE 190MM (02)

Y PÉ/FOOT/PIE 190MM (02)

W VISTA LATERAL PÉ/ SIDE FOOT VIEW/ VISTA LADO PIE 22X50X298 MM (02)

Z VISTA FRONTAL PÉ/ FRONT FOOT VIEW/ VISTA FRONT DEL PIE 22X50X588MM (02)

PREPARAÇÃO DE PEÇAS / PARTS PREPARATION / PREPARACION DE PIEZAS

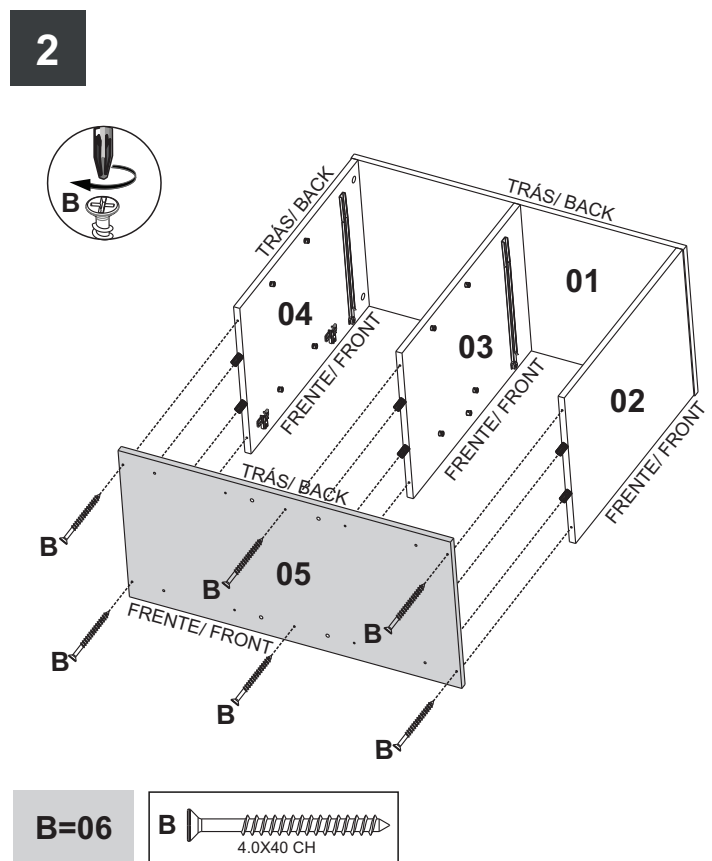
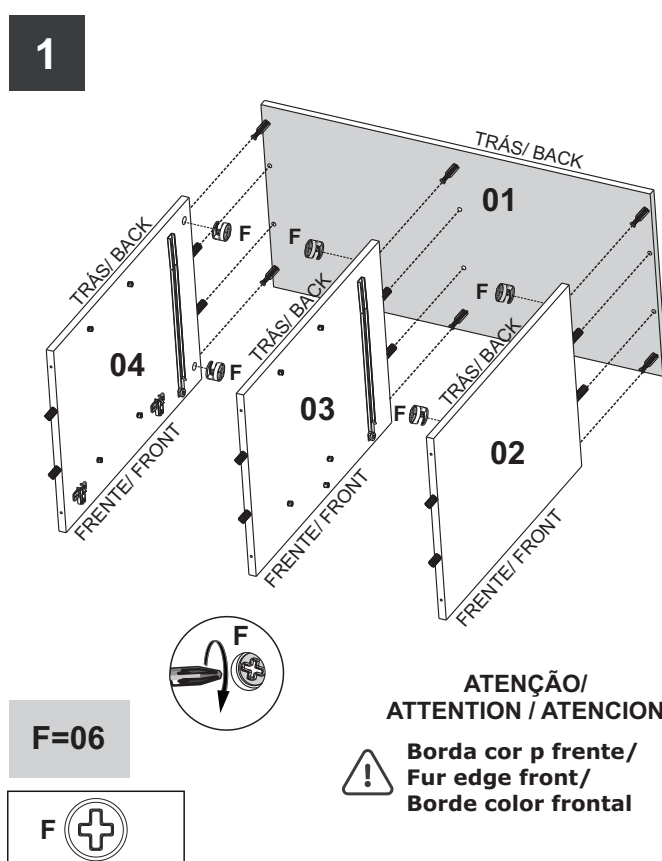
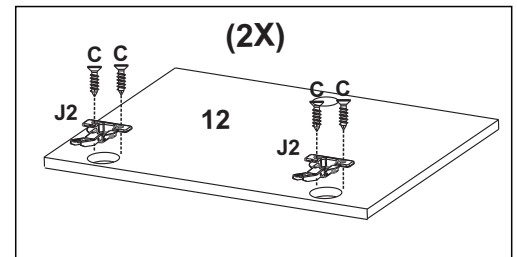
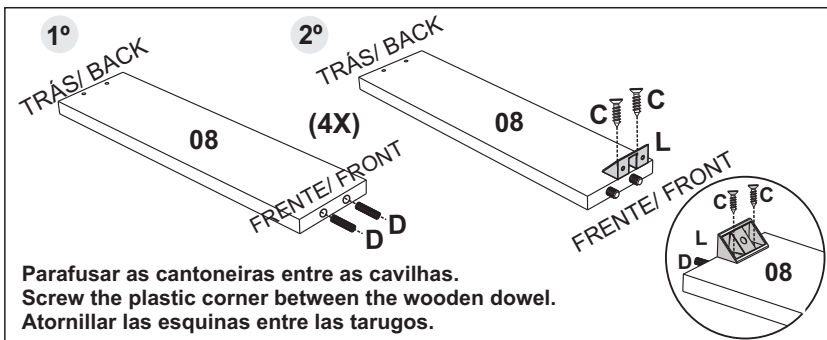
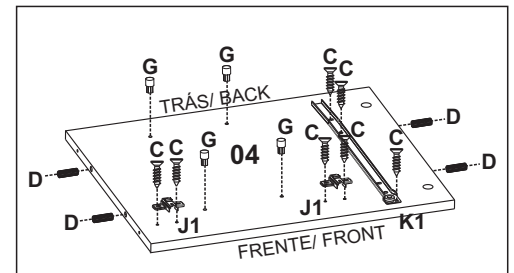
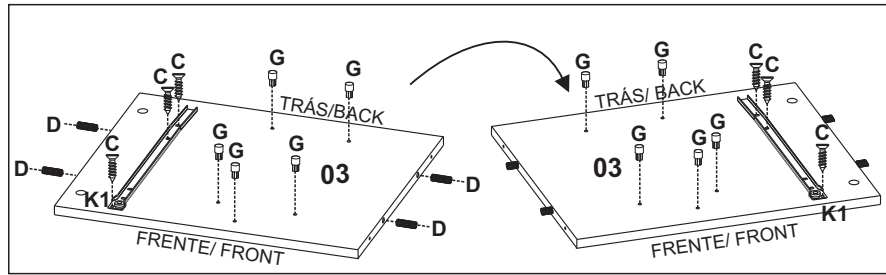
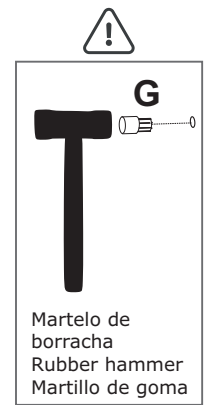
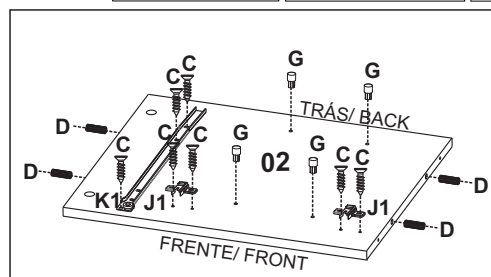
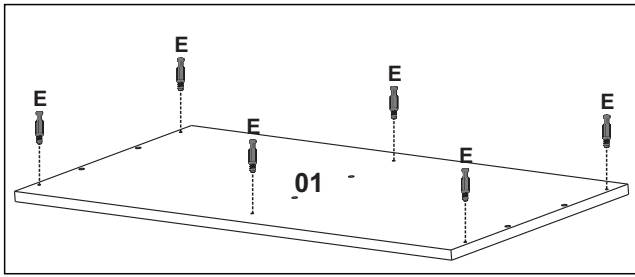
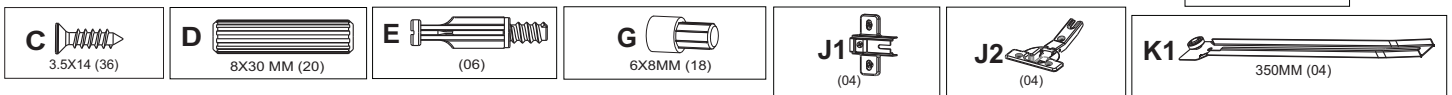
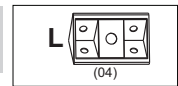

3

ATENÇÃO/
ATTENTION / ATENCION

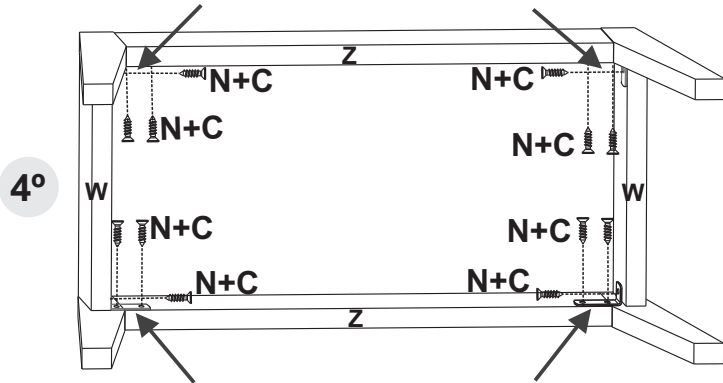
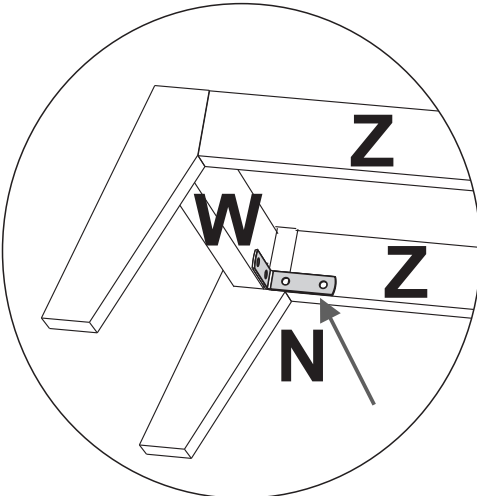
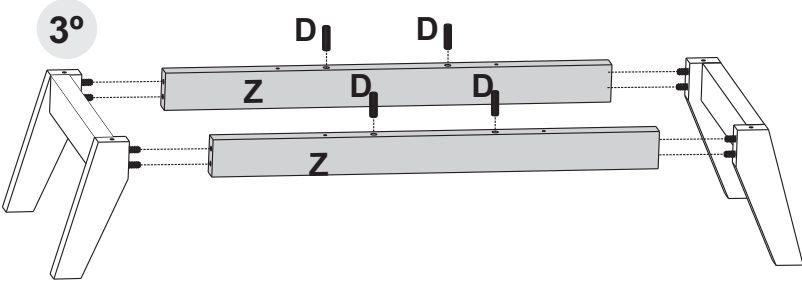
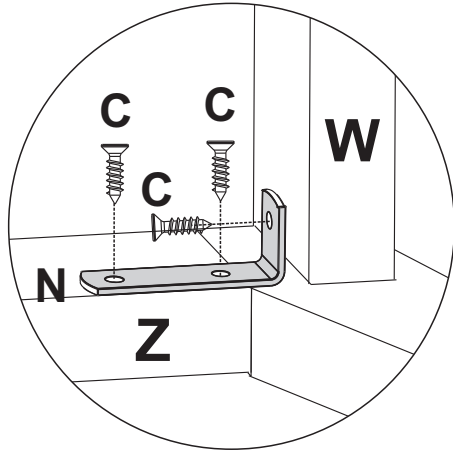
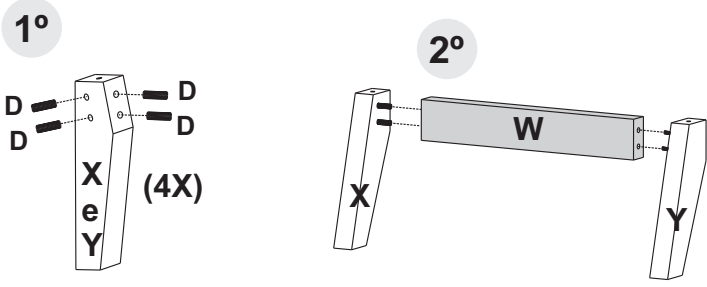

- C=12
- D=20
- N=04
- Z=02
- W=02
- X=02
- Y=02

C 3,5X14 MM 	D 8X30 MM 	N 	Z 588X50X22MM 	W 298X50X22 MM 	X 190MM 	Y 190MM
---------------------------	-------------------------	--------------	-----------------------------	------------------------------	-----------------------	-----------------------

4

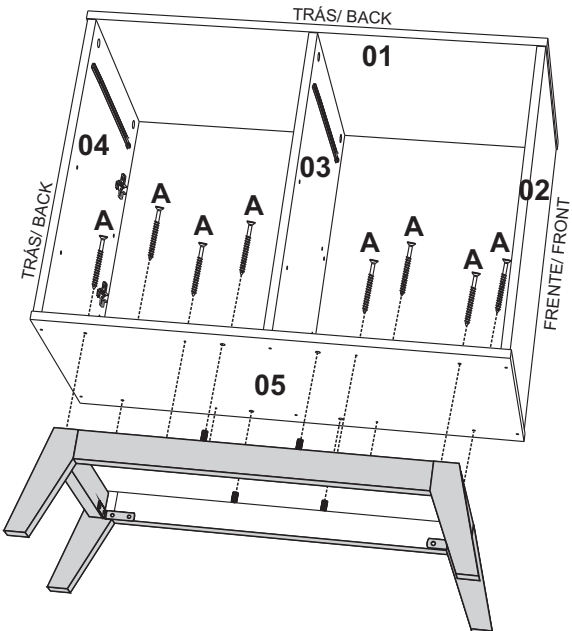

A=08



5

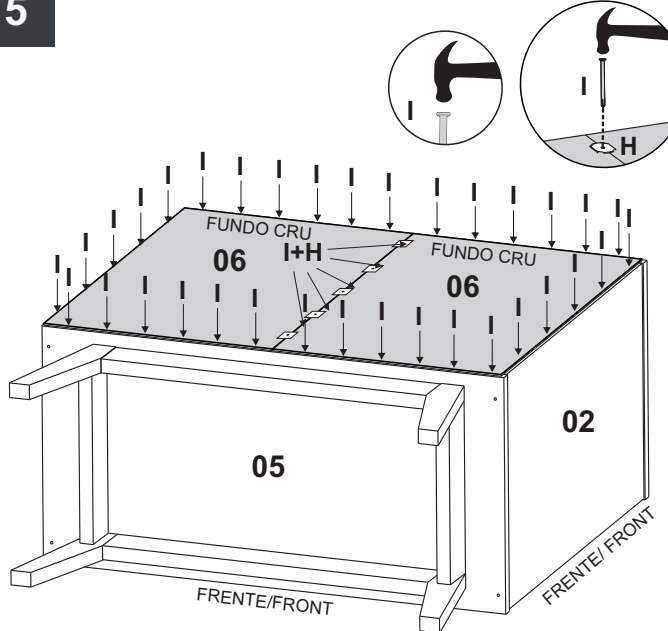

H=05
I=40

6

MONTAGEM GAVETA / ASSEMBLY OF THE DRAWER / MONTAJE LE CÁJON

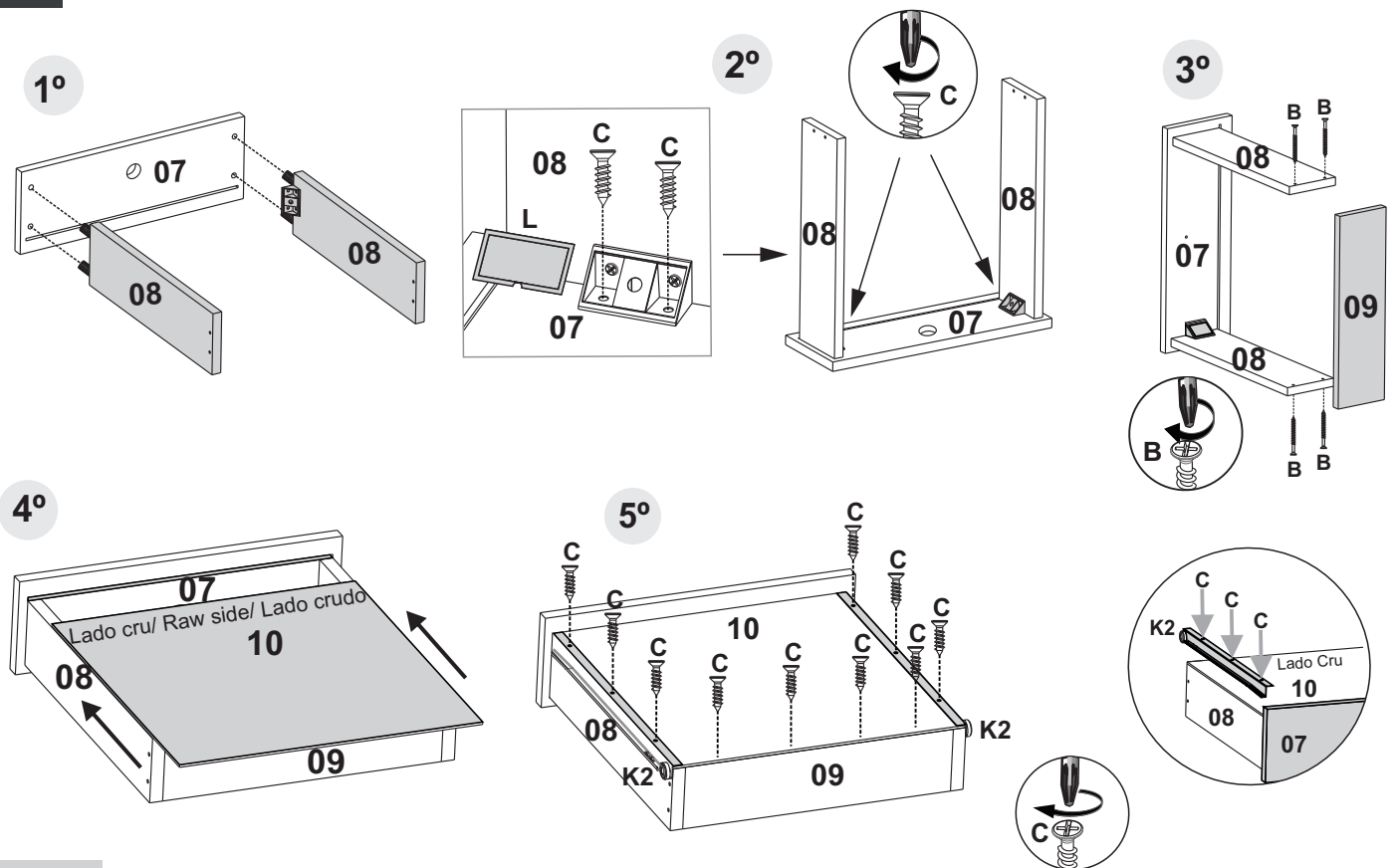

B=08
C=28
K2=04
L=04

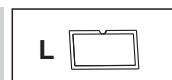
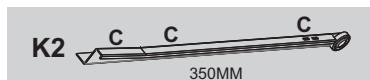
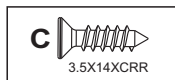
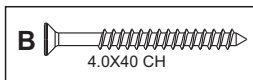

7

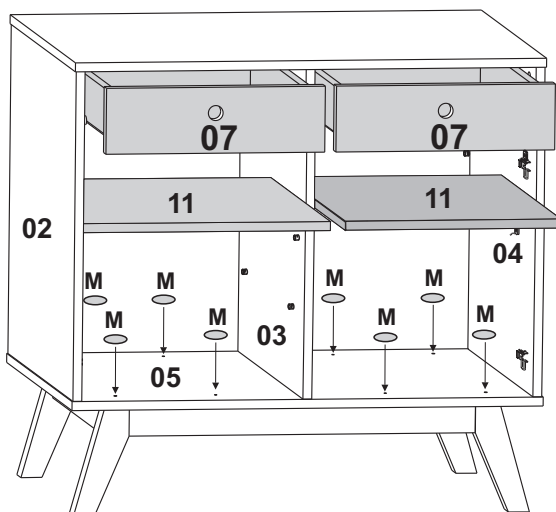

M=08



8



FIXAR DOBRADIÇAS / FIXING THE HINGE / BISAGRA

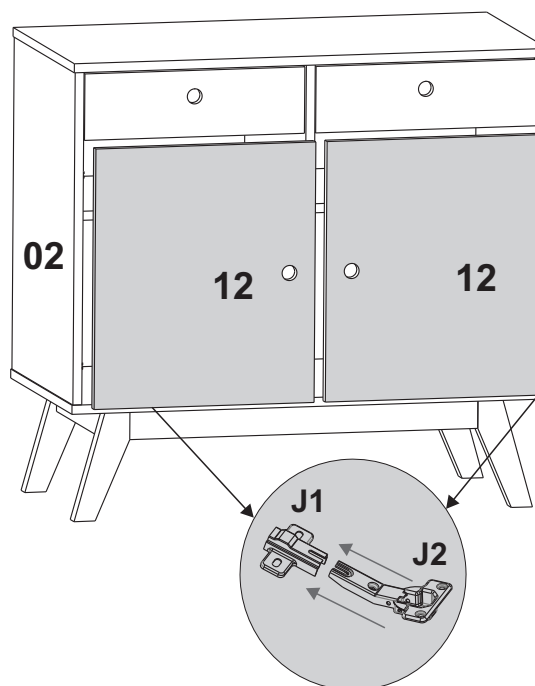

Regular e apertar / Adjust and tighten / Ajuste y apriete

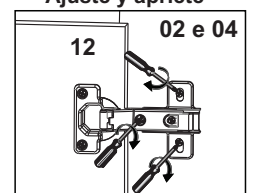

NOTA / NOTE

Não nos responsabilizamos por acidentes, se a instalação do móvel não estiver com os procedimentos deste Manual e não for realizado por pessoa habilitada. We are not responsible for accidents if the installation of the furniture is not in accordance with the procedures in this Manual and is not carried out by a qualified person. No nos hacemos responsables de accidentes si la instalación de los muebles no se realiza de acuerdo con los procedimientos de este Manual y no es realizada por una persona calificada.