

CO8105- COZINHA

Manual de Montagem
Assembly Instructions
Instrucción de Montaje

decibal[®]
móveis

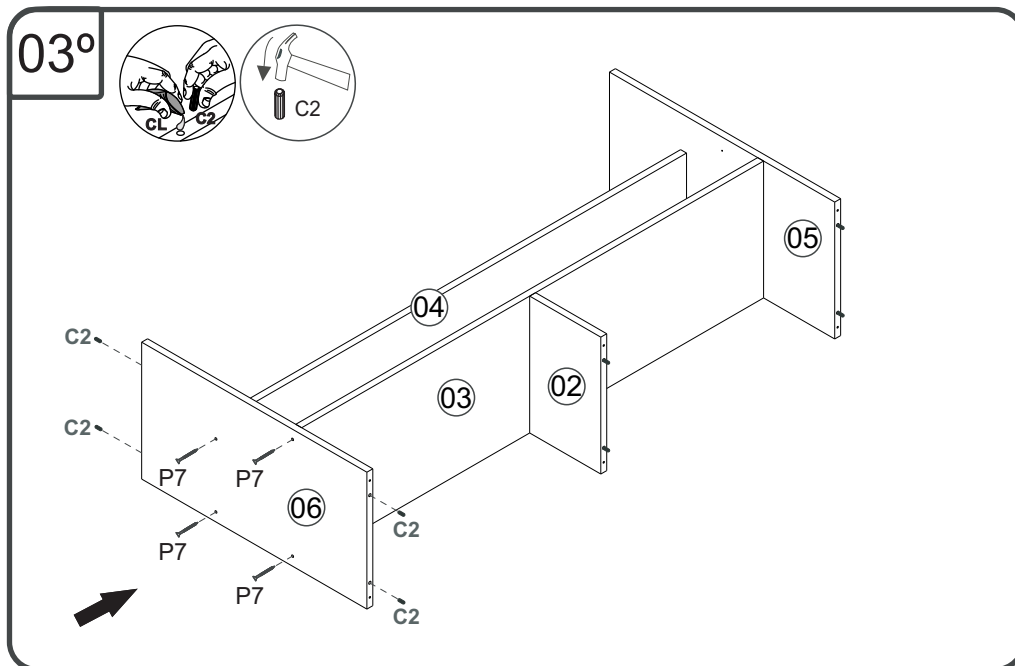
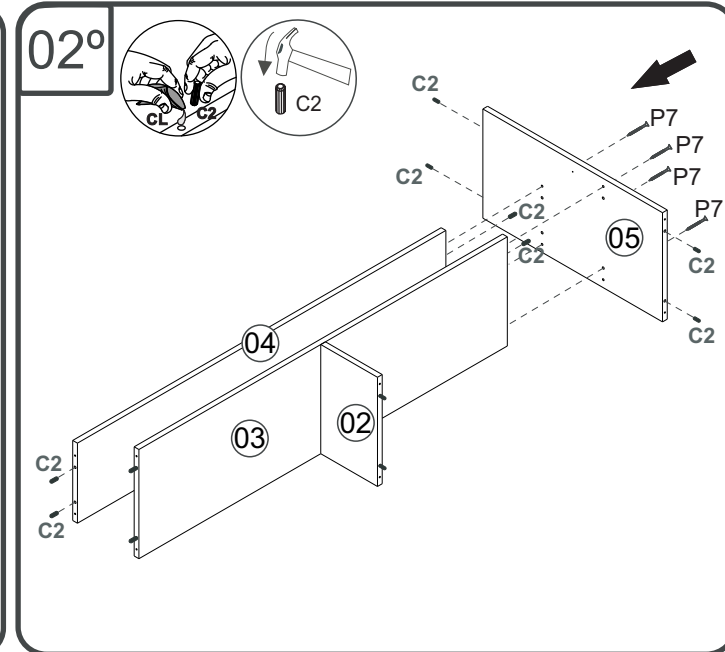
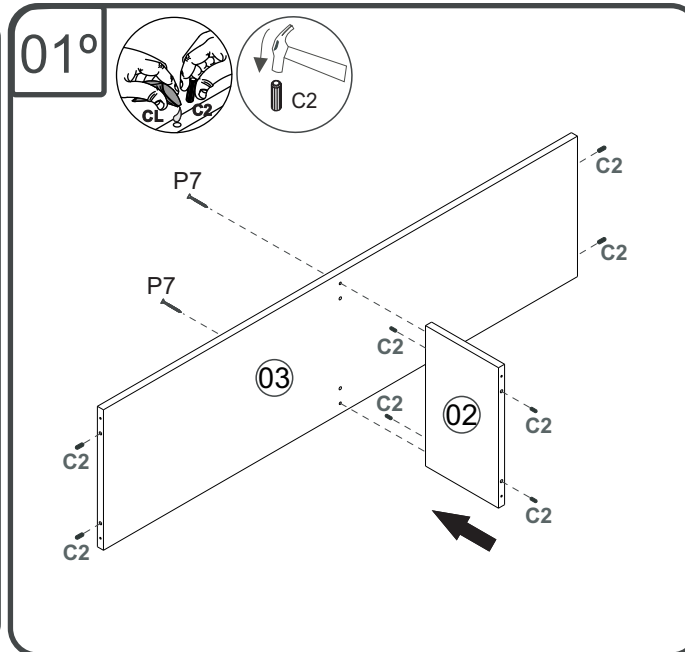
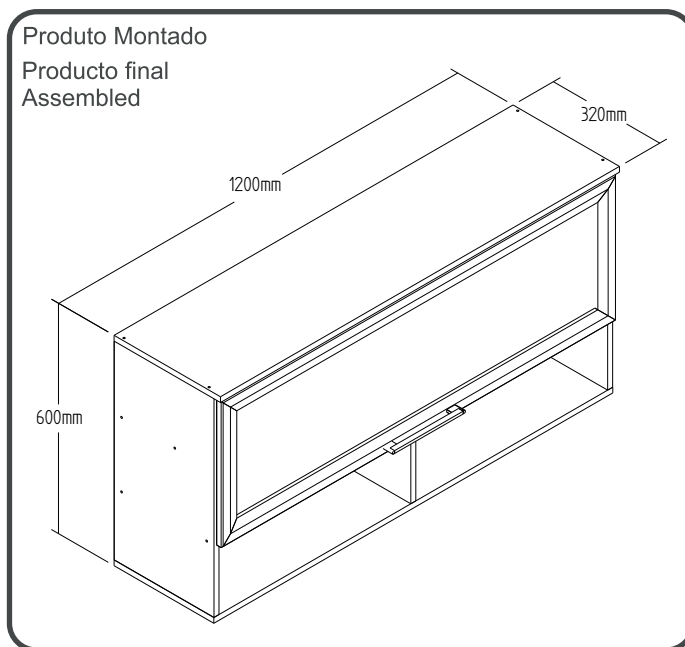

- ATENÇÃO!!!! montadores e consumidores**
* Ajustar o torque da parafusadeira para não danificar as peças escareando o parafuso *
- ATENCIÓN!!!! montadores e consumidores**
* Ajuste el torque del destornillador para no dañar las piezas avallanando el tornillo *
- ATTENTION!!!! assemblers and consumers**
* Adjust the torque of the screwdriver so as not to damage the parts by countersinking the screw *

ATENÇÃO!!!! montadores e consumidores

* Para limpar o móveis utilize somente um pano úmido (umedecido em água pura ou água com sabão neutro). Depois, passe um pano seco. Evite a umidade excessiva.

* Evite usar álcool, água sanitária, detergente e outros produtos químicos, mesmo diluídos em água. Não utilize produtos abrasivos de nenhuma espécie

ATENCIÓN!!!! montadores e consumidores

* Para limpiar el mueble utilice solamente un paño húmedo (humedecido con agua limpia o con un jabón suave). A continuación, utilice un paño seco. Evite el exceso de humedad.

* Evite uso de alcohol, hipoclorídico solución basada, detergente y otros productos químicos, mismo diluídos en agua. No utilice productos abrasivos de ningún tipo.

ATTENTION!!!! assemblers and consumers

* To clean the furniture, use only a damp cloth (humidify it only in pure water ou water and neutral soap). After, use a dry cloth. Avoid excessive humidity. *Avoid using alcohol, bleach, detergent and other chemical products, even diluted in water. Do not use any kind of abrasive cleaning agents to clean the furniture.

The use of such products may jeopardize the final characteristics of the furniture.

CO8105 - COZINHA

04°

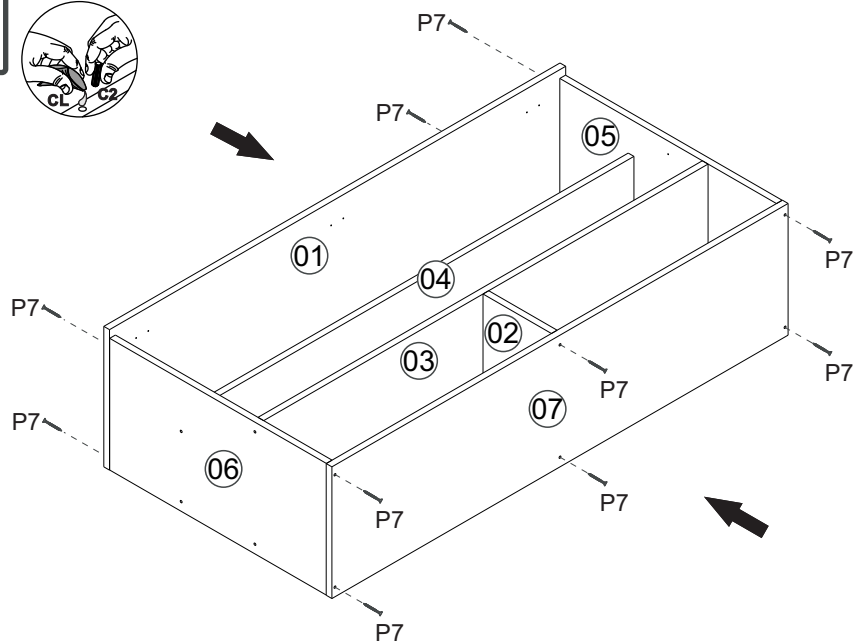

06°

COSTA/REVÉS/BACK

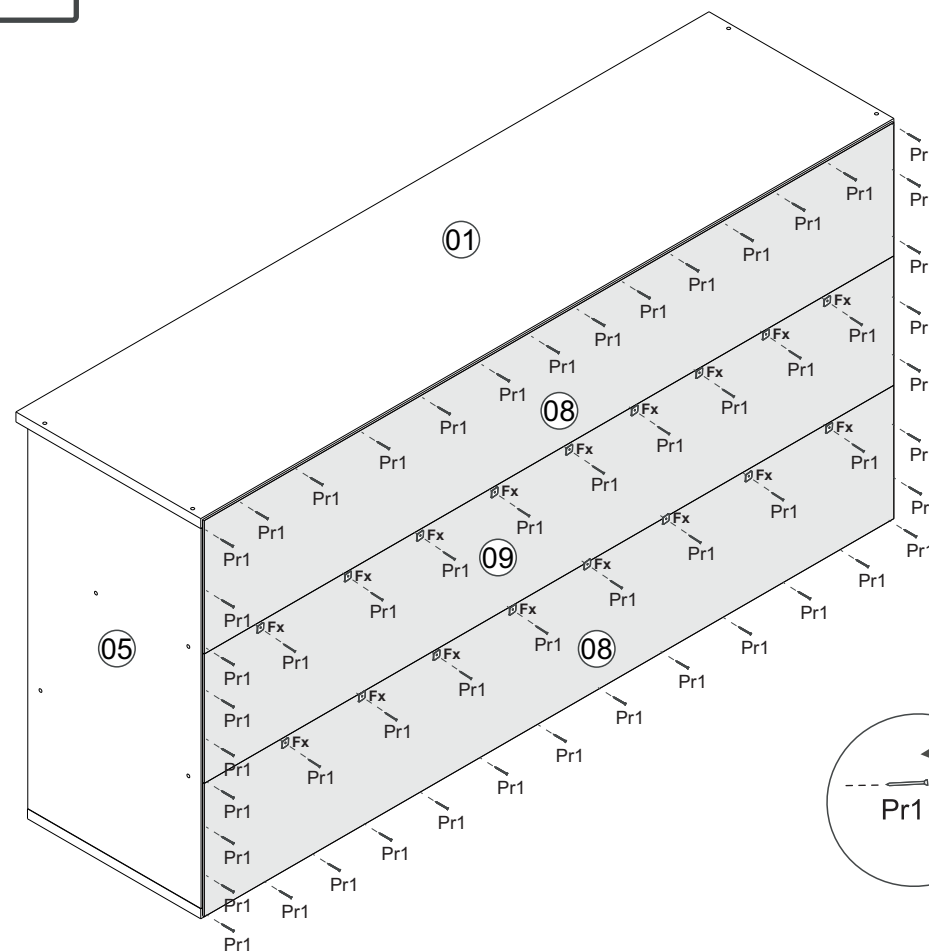

05°

COSTA/REVÉS/BACK

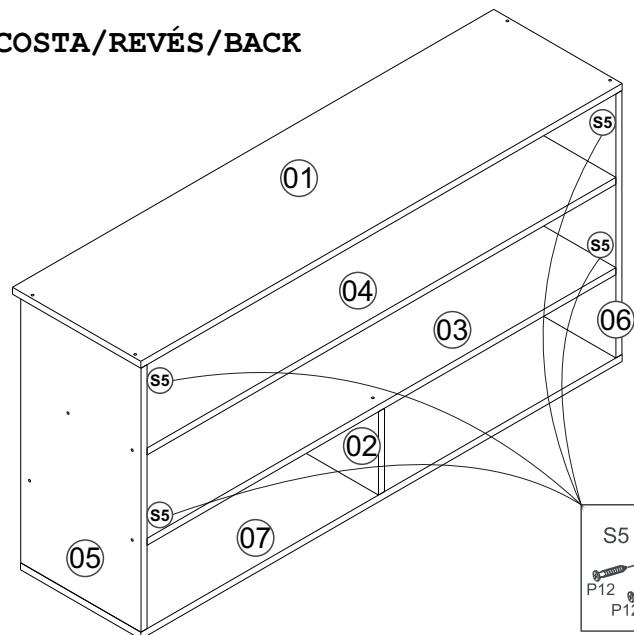

www.decibal.com.br



40 min.



2 montador
2 ajustador
2 fitter

CO8105 - COZINHA

Manual de Montagem
Assembly Instructions
Instrucción de Montaje

decibal[®]
móveis

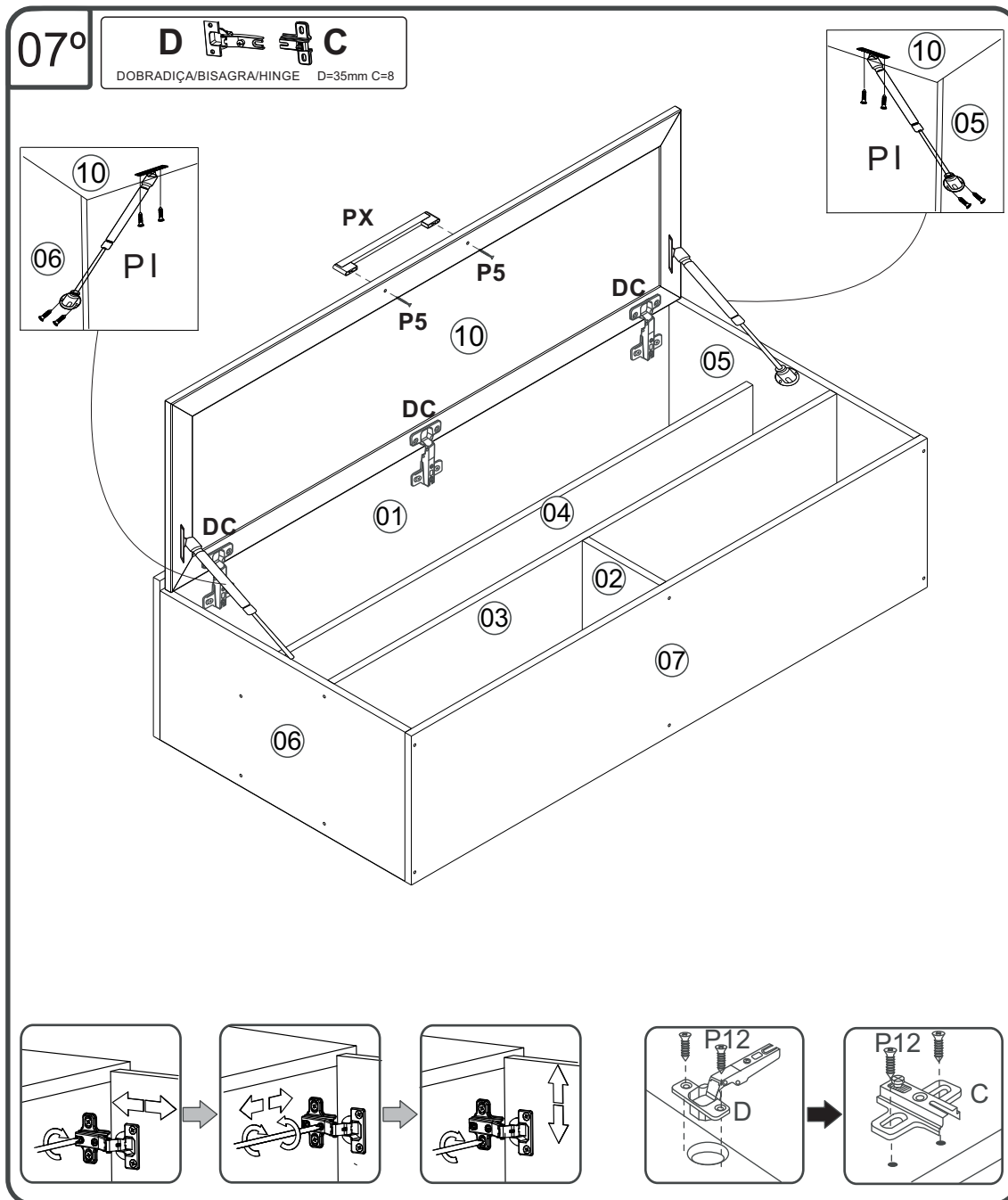

PESO SUPORTADO/PESO SOPORTADO/ WEIGHT SUPPORTED

S5	2KG	2KG	S5
S5	3KG	3KG	S5
	2KG	2KG	

FIXAÇÃO NA PAREDE/FIJACIÓN EN LA PARED/FIXING ON THE WALL

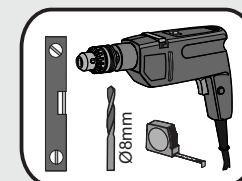
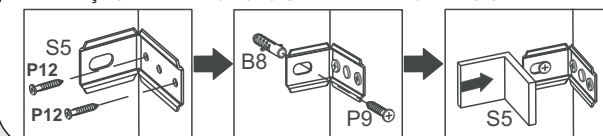

Relação de Peças/ Relación de Piezas/Parts List

N°	CÓDIGO/CODE	DESCRIÇÃO/DESCRIPCIÓN/DESCRIPTION	QTD/CANT	VOL.
1	0549071	TAMPO/TAPA/TOP 1200X320X15MM	1,00	1
2	0549075	DIVISÓRIA/DIVIDER 300X180X15MM	1,00	1
3	0549072	PRATELEIRA/ESTANTE/SHELF 1169X300X15MM	1,00	1
4	0549073	PRATELEIRA MENOR/ESTANTE/SHELF 1169X220X15MM	1,00	1
5	0549069	LATERAL DIR/LATERAL/SIDE 570X300X15MM	1,00	1
6	0549070	LATERAL ESQ/LATERAL/SIDE 570X300X15MM	1,00	1
7	0549068	BASE 1200X300X15MM	1,00	1
8	0549074	COSTA/REVÉS/BACK 1194X200X2,8MM	2,00	1
9	0549631	COSTA MEIO/REVÉS/BACK 1194X194X2,8MM	1,00	1
10	11937	PORTA/PUERTA/DOOR 1186X338X18MM	1,00	1

CO8105 - COZINHA







Manual de Montagem
Assembly Instructions
Instrucción de Montaje











Ferragens/ Herrajes/ Hardware

escala (1:1)

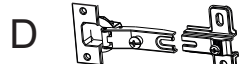
escala (N/A)

LEGENDA	DESCRIÇÃO/DESCRIPCIÓN/DESCRIPTION	CÓDIGO	QUANT.
P7	 PARAFUSO/TORNILLO/SCREW 4X45	01318	20
PR1	 PREGO/CLAVO/NAIL 10X10	01330	55
C2	 CAVILHA/TARUGO/DOWEL 6X30 MM	01211	21
P12	 PARAFUSO/TORNILLO/SCREW 3,5X13	09927	20
PU	 PARAFUSO UNIÃO/UNIÓN DETORNILLO /SCREW UNION	01495	02
P5	 PARAFUSO/TORNILLO/SCREW 3,5X25	09955	02
P9	 PARAFUSO/TORNILLO/SCREW 6X50	03827	04

LEGENDA	DESCRIÇÃO/DESCRIPCIÓN/DESCRIPTION	CÓDIGO	QUANT.
CL	 COLA/PEGAMENTO/GLUE	01213	01
ET	 ETIQUETA LOGO DECIBAL/LABEL DECIBAL	01312	01
B8	 BUCHA/BUJE/BUCHING 8MM	01311	04
PI	 PISTÃO GÁS / PISTÓN DE GAS /GAS PISTON	01265 80N	02
DC	 DOBRADIÇA/BISAGRA/HINGE D=35mm C=8mm	04043	03
S5	 SUPORTE AÉREO/APOYO AÉREO/AIR SUPPORT	WOOD 09647	04
FX	 FIXADOR COSTA/FIJADOR FONDO/FIXER COAST	01331	18
AD	 ADESIVO/ADHESIVO/ADHESIVE 22mm	WOOD 09929 NATURALLE 09963	15
PX	 PUXADOR/ PEGADOR/HANDLE	11020	03

Ferramente necessárias
Necessary tools
Herramientas necesarias



Medida em mm

