

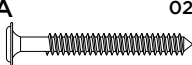









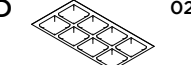
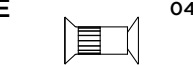
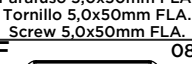
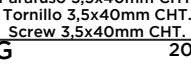
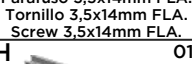
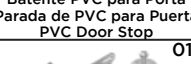

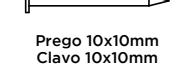
Item	Caixa Caja Box	Qtd Ctd Qty	Descrição Descripción Description	Medidas (mm) Dimensions (mm) Size (measurements) (mm)
01	1/1	01	Base Base Base	800x310x15
02	1/1	02	Lateral Direita Esquerda Lateral Derecha Izquierda Right Side Left	307x295x15
03	1/1	01	Tampo Tapa Top	800x310x15
04	1/1	01	Fundo Fondo Bottom	792x331x3
05	1/1	01	Porta Basculante Puerta Basculante Basculating Door	795x274x15
05	1/1	01	Porta Basculante Puerta Basculante Busculating Door (Somente para C54-139)	796x277x15

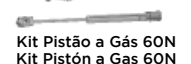
Ferragens | Herrajes | Hardware

A  Parafuso 5,0x50mm FLA. Tornillo 5,0x50mm FLA. Screw 5,0x50mm FLA.	B  Parafuso 3,5x40mm CHT. Tornillo 3,5x40mm CHT. Screw 3,5x40mm CHT.	C  Parafuso 3,5x14mm FLA. Tornillo 3,5x14mm FLA. Screw 3,5x14mm FLA.	D  Batente PVC para Porta Parada de PVC para Puerta PVC Door Stop	E  Parafuso União 15mm Tornillo Unión 15mm Union Screw 15mm
F  Cavilha 8x25mm Cinta 8x25mm Dowel 8x25mm	G  Prego 10x10mm Clavo 10x10mm Nail 10x10mm	H  Puxador Alum. MOV 795mm Tirador Alum. MOV 795mm Handle Alum. MOV 795mm	I  Kit Pistão a Gás 60N Kit Pistón a Gas 60N 60N Gas Piston Kit	J  Calço metal Super Alto 8mm Calzado metálico Super Alto 8mm Super 8mm metal chock
K  Dobradiça metal 35mm Alta Bisagras metálicas 35mm Alta Metal hinge 35mm High	L  Buchta plástica 8mm Buchta de plástico 8mm 8mm plastic bushing	M  Suporte de fixação Soporte de fijación Mounting bracket	N  Proteção para cantoneira Ángulo de protección Protection angle	O  Sachê de cola Bolsa de pegamento Glue bag
P  Adesivo tapon de tornillo 10mm Bolt cover adhesive 10mm	Q  Parafuso União 30mm Tornillo Unión 30mm Union Screw 30mm	R  Parafuso 3,5x12mm CHT. Tornillo 3,5x12mm CHT. Screw 3,5x12mm CHT.	S  Puxador MOV4083 - 792mm Tirador MOV4083 - 792mm MOV4083 - 792mm Handle	T  Kit Ponteira Plastica MOV4083 Kit de punta de plástico MOV4083 Plastic Tip Kit MOV4083

O parafuso (Q) deve ser usada somente quando este módulo for acoplado a outro módulo componível Henn.

El tornillo (Q) se debe utilizar sólo cuando el módulo está conectado a otro módulo componible Henn.

The screw (Q) should be used only when this module is attached to another Henn modular module.

RECOMENDAÇÃO

Para fixar o móvel na parede usar o suporte de fixação (M), o parafuso 3,5x14mm FLA (C), a Bucha 8mm (L) e o parafuso 5,0x50mm FLA (A).

RECOMENDACIÓN

Para conectar el móvil a la pared con el soporte (M), tornillo 3,5 x14mm FLA (C), el casquillo de 8 mm (L) y el 5,0 x50mm tornillo FLA (A).

RECOMMENDATION

To fix the furniture to the wall use the fixing bracket (M), the 3.5x14mm FLA (C) screw, the 8mm bushing (L) and the 5.0x50mm FLA screw (A).

HENN

Ind. e Com. de Móveis Henn
Mondai - SC - Brasil

+55 49 3674.3500

@moveishenn
www.henn.com.br

INSTRUÇÕES DE MONTAGEM

INSTRUCCIONES DE MONTAJE
ASSEMBLY INSTRUCTIONS

Aéreo 01 Porta Basculante 800mm Connect |
Aéreo 01 Puerta Basculante 800mm Connect |
01 air port Tipper 800mm Connect

- C54-35 - Duna/Cristal
- C54-42 - Fendi
- C54-139 - Off White

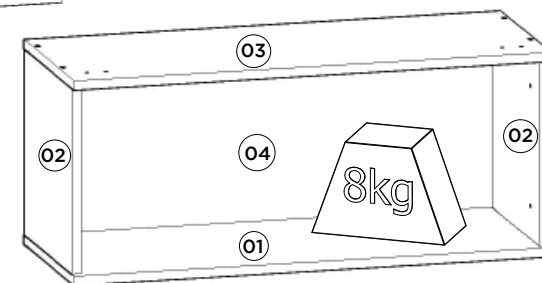
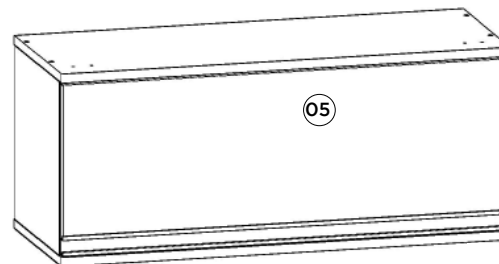

Pesos máximos recomendados com carga distribuída
Peso máximo recomendado con la carga distribuida
Recommended maximum weight with distributed load.

Requisitos para montagem
Requisitos para la montaje
Assembly Requirements

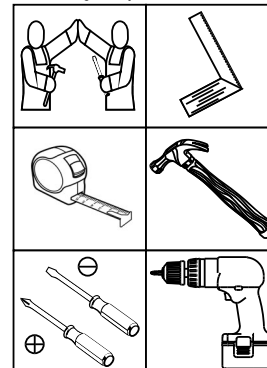

Imagens meramente ilustrativas
Imágenes meramente ilustrativas
Images for illustration only

AVISO

Para limpeza de seu móvel, use uma flanela seca ou umedecida, e não utilize produtos químicos que possam danificar seu produto.

SISTEMA DE MONTAGEM

O sistema de montagem dos produtos, funciona de acordo com a ordem crescente dos números indicados no desenho. Ex: 01, 02, 03, 04... até a conclusão da montagem.

ASSISTÊNCIA TÉCNICA

Para solicitação de Assistência Técnica você consumidor deverá entrar em contato com o Lojista o qual você realizou a compra deste produto e solicitar a assistência técnica das peças avariadas. A garantia abrange todas as peças, partes e componentes que eventualmente venham apresentar defeito de fabricação no prazo de 03 (três) meses, contando a partir da entrega do produto ao consumidor, mediante nota fiscal de compra. Se houver qualquer alteração na estrutura do produto ou ocorrer defeito por negligência do montador/consumidor em relação a instrução de montagem e manuseio, não será fornecido assistência técnica gratuita.

ADVERTENCIA

Para limpieza de su móvil, use una flanela seca o húmeda, y no utilice productos químicos que puedan dañar su producto.

SISTEMA DE MONTAJE

El sistema de montaje de los productos funciona de acuerdo con el orden creciente de los números indicados en el dibujo. Ej.: 01, 02, 03, 04... hasta la conclusión del montaje.

ASISTENCIA TÉCNICA

Para solicitar Asistencia Técnica, el consumidor debe comunicarse con el Comercio que usted realizó la compra de este producto y solicita asistencia técnica para las partes dañadas. La garantía cubre todas las partes, piezas y componentes que eventualmente puedan presentar defecto de fabricación en el plazo de 03 (tres) meses, contados a partir de la entrega del producto al consumidor, mediante factura de compra. Si se produce algún cambio en la estructura del producto o se produce un defecto por negligencia del montador/consumidor en relación con las instrucciones de montaje y manipulación, no se prestará asistencia técnica gratuita.

NOTICE

To clean your furniture, use a dry or wet cloth, and do not use chemicals that may damage your product.

ASSEMBLY SYSTEM

The products' assembly system works according to the increasing order of the indicated numbers. For example: 01, 02, 03, 04 ... to the end of the assembly.

TECHNICAL ASSISTANCE

To request Technical Assistance, the consumer must contact the retailer from whom you purchased this product and request technical assistance for the damaged parts. The warranty covers all parts, parts and components that may eventually present a manufacturing defect within a period of 03 (three) months, counting from the delivery of the product to the consumer, by means of a purchase invoice. If there is any change in the structure of the product or defect occurs due to negligence of the assembler/consumer in relation to the assembly and handling instruction, free technical assistance will not be provided.

1º

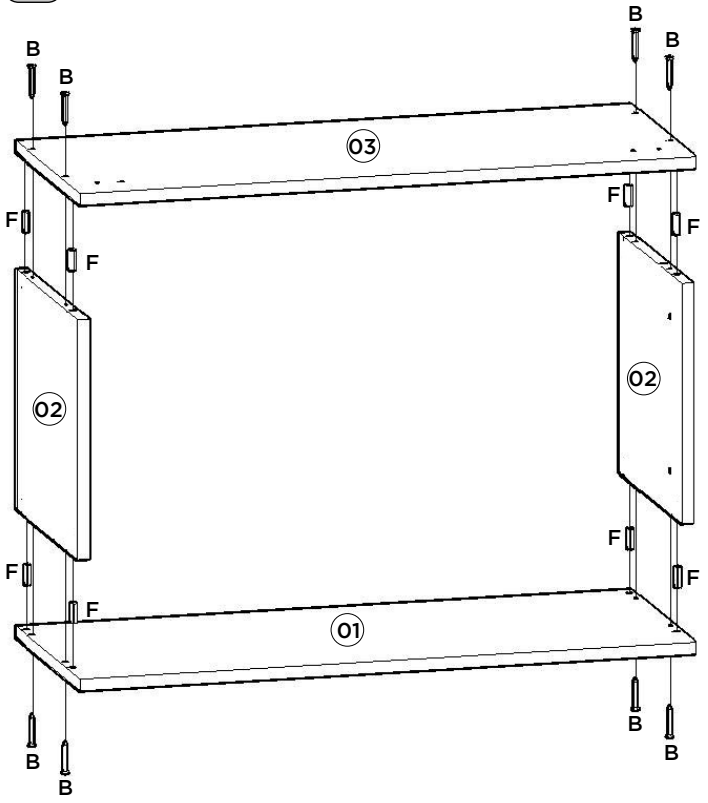

Utilizar o sachê de cola (O) em todas as cavilhas (F) do produto.

Con el pegamento sobre (O) en todos los pernos (F) producto.

Use the glue sachet (O) on all the pegs (F) of the product.

2º

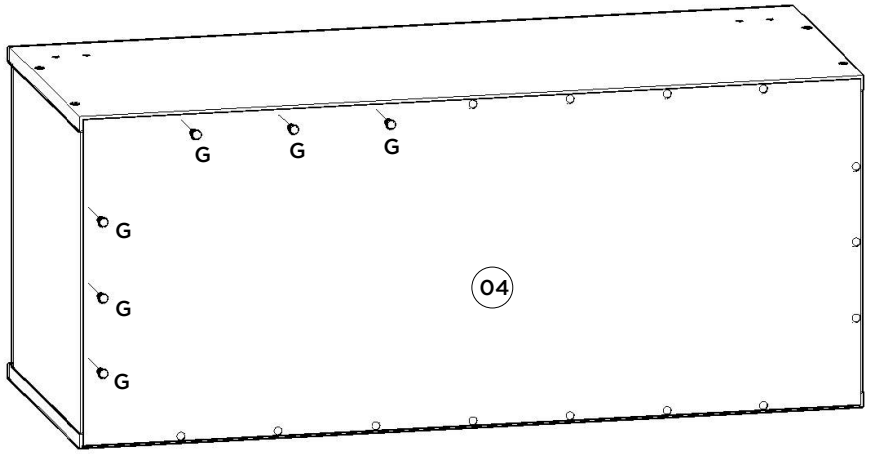

3º

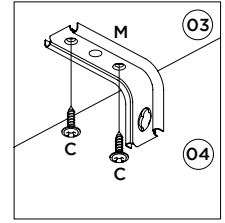
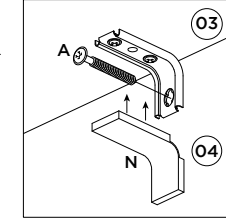
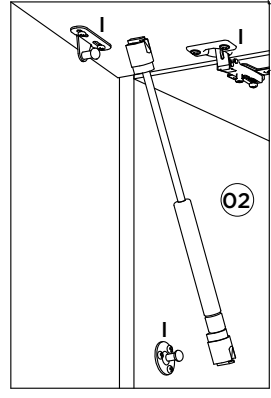
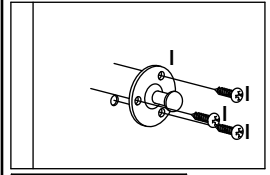
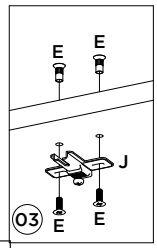
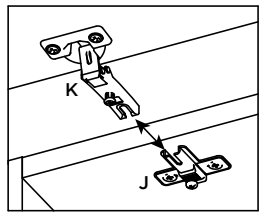
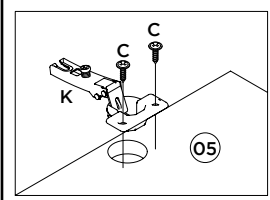
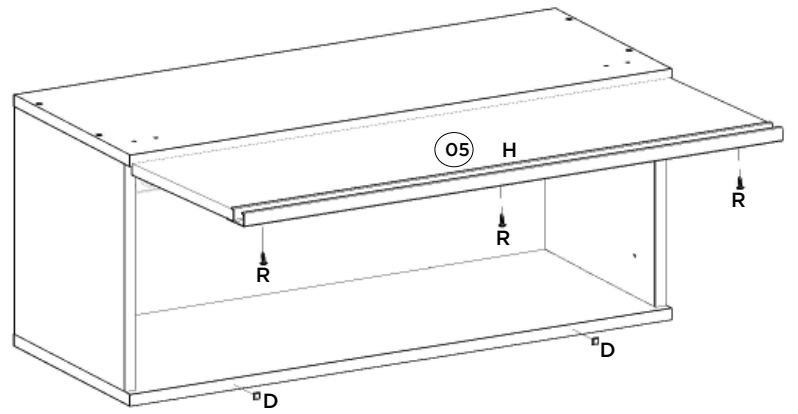

- Video: Instalar e regular Dobradiças
- Video: Instale y ajuste las bisagras
- Video: Install and adjust hinges

- Video: Dicas para instalar o Kit Pistão à Gás
- Video: Consejos para instalar el kit de pistón de gas
- Video: Tips for installing the Gas Piston Kit



- Somente para (C54-139)
- Solo para (C54-139)
- Only for (C54-139)

