

# CO14400 - AÉREO 1,20 M

Manual de Montagem  
Assembly Instructions  
Instrucción de Montaje

decibal<sup>®</sup>  
móveis

Produto Montado  
Producto final  
Assembled

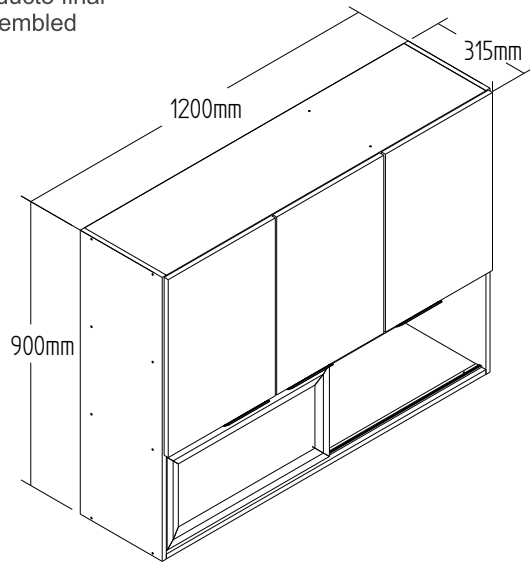

01°

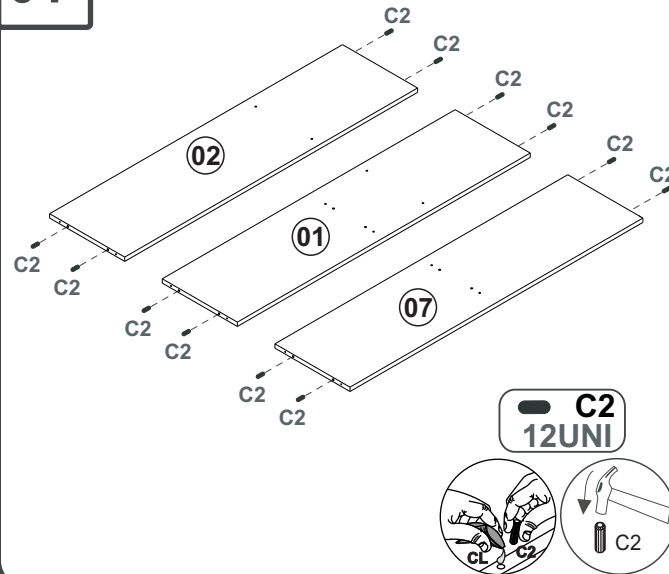

02°

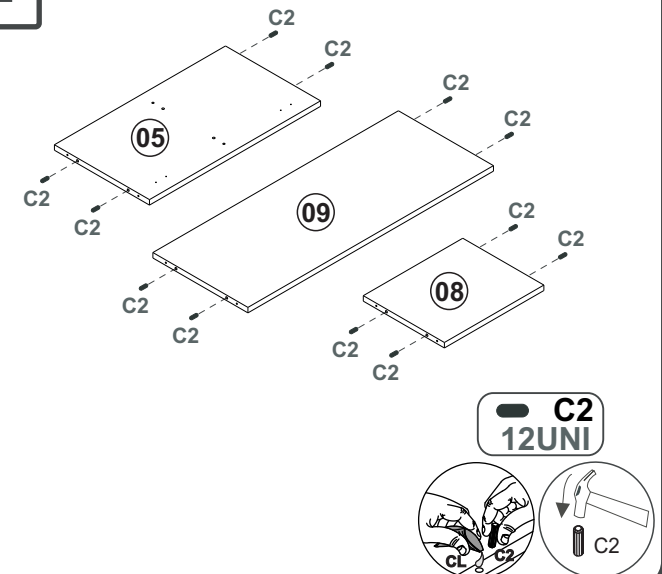

3°

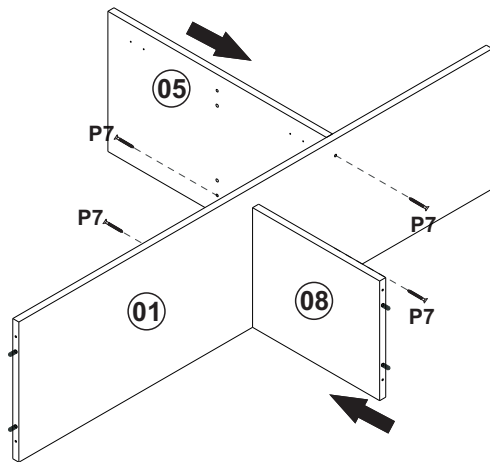

P7  
4 UNI



4°

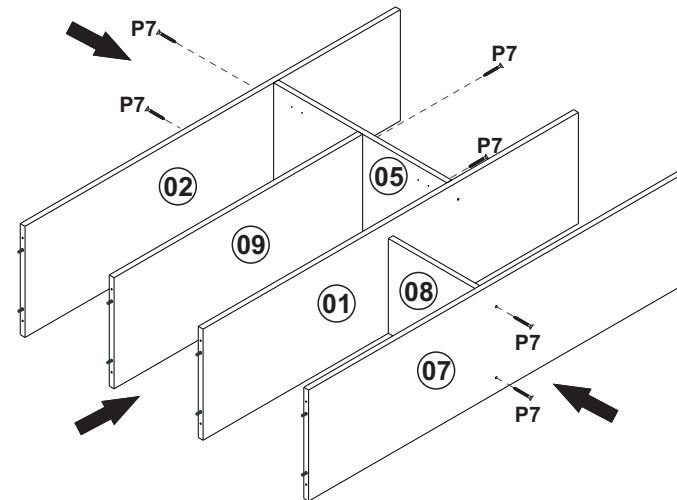

P7  
6 UNI



# CO14400 - AÉREO 1,20 M

Manual de Montagem  
 Assembly Instructions  
 Instrucción de Montaje



**5°**

P7 14 UNI

**7° COSTA/REVÉS/BACK**

S5 P12

**6°**

ATENÇÃO!!!!  
 MARCAÇÃO PRA O TRILHO  
 MARCADO PARA EL RIEL  
 MARKING FOR THE RAIL

2cm

2,2cm

**8° COSTA/REVÉS/BACK**

PR1

# CO14400 - AÉREO 1,20 M

Manual de Montagem  
Assembly Instructions  
Instrucción de Montaje

decibal<sup>®</sup>  
móveis

9°

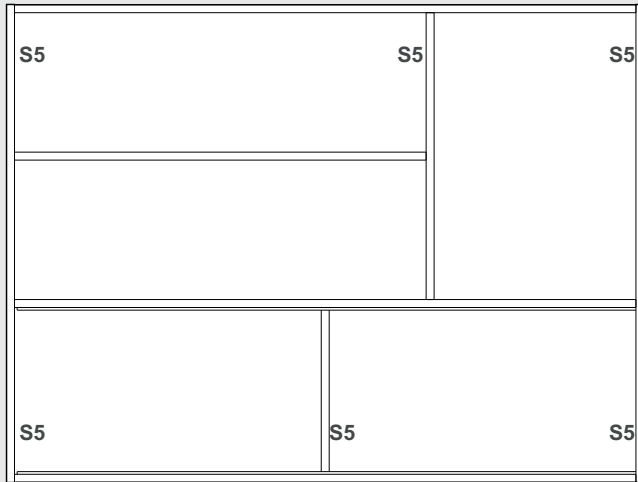

Fixação parede  
Fixed in the wall

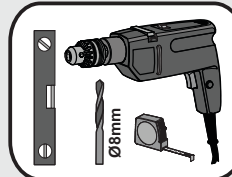
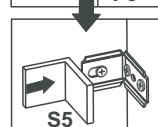
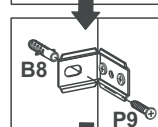

11°

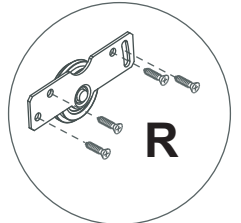
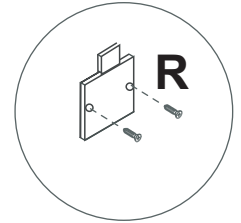
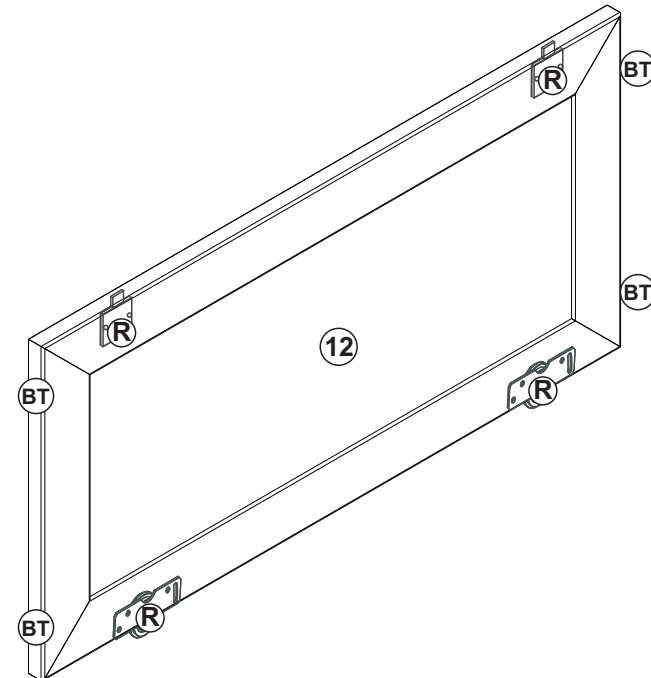

10°



\*PESO SUPORTADO.  
\*PESO SOPORTADO.  
\*WEIGHT SUPPORTED.

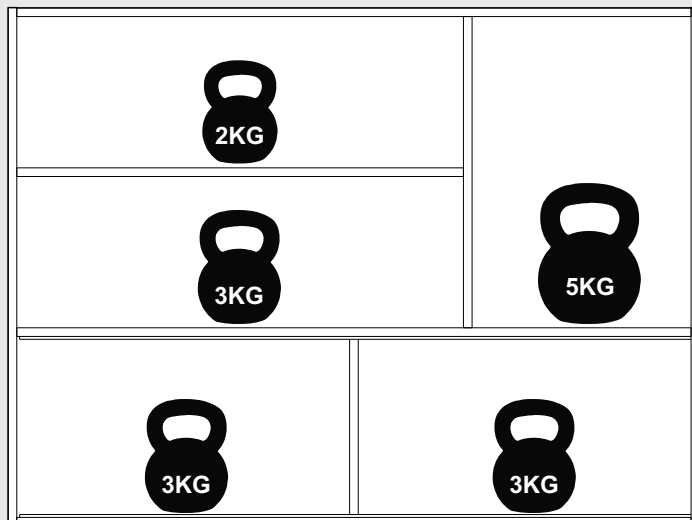

[www.decibal.com.br](http://www.decibal.com.br)

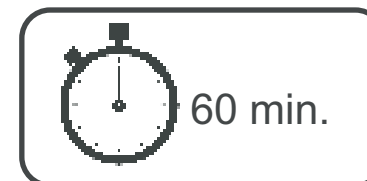

12°

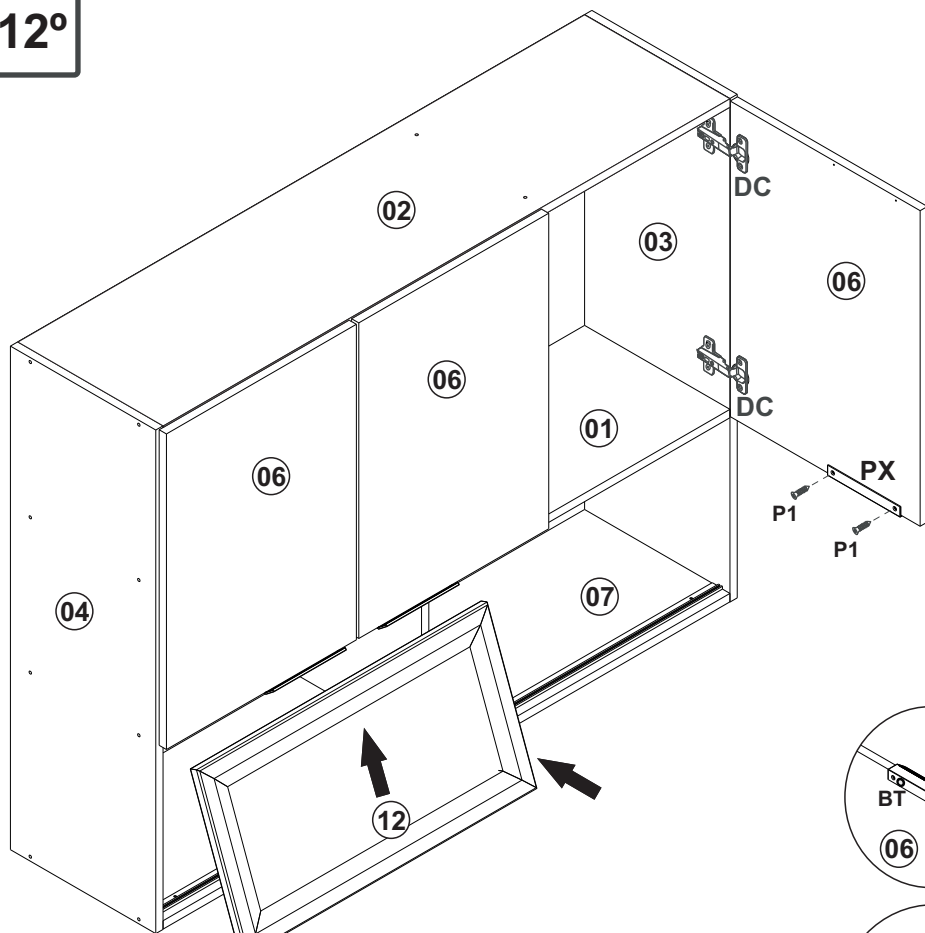

**ATENÇÃO!!!!**  
MARCAÇÃO PRA O PRIMEIRO FURO DO PUXADOR  
MARCADO PARA EL PRIMER AGUJERO  
MARKING FOR THE FIRST HANDLE HOLE

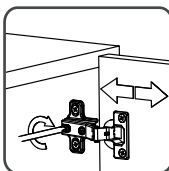
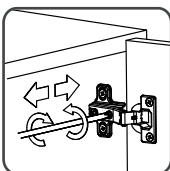
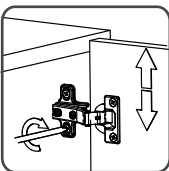
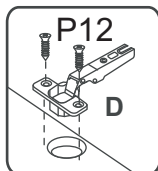
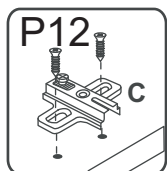
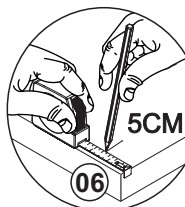
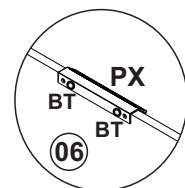

## Relação de Peças/ Relación de Piezas/Parts List

N°	CÓDIGO/CODE	DESCRIÇÃO/DESCRIPCIÓN/DESCRIPTION	QTD/CANT	VOL.
1	0560790	BASE INT	1	1
2	0560789	BASE SUP	1	1
3	0560787	LATERAL DIR/LATERAL/SIDE	1	1
4	0560788	LATERAL ESQ/LATERAL/SIDE	1	1
5	0560791	DIVISORIA SUP/DIVIDER	1	1
6	0560793	PORTA/PUERTA/DOOR	3	1
7	0560786	BASE INF	1	1
8	0560792	DIVISORIA INF/DIVIDER	1	1
9	0560794	PRATELEIRA/ESTANTE/SHELF	1	1
10	0560796	COSTA SUP/REVÉS/BACK	1	1
11	0560795	COSTA INF/REVÉS/BACK	1	1
12	12449	PORTA MOLDURA/PUERTA/DOOR	1	1

**ATENÇÃO!!!! montadores e consumidores**

\* Ajustar o torque da parafusadeira para não danificar as peças escareando o parafuso \*

**ATENCIÓN!!!! montadores e consumidores**

\* Ajuste el torque del destornillador para no dañar las piezas avallando el tornillo \*

**ATTENTION!!!! assemblers and consumers**

\* Adjust the torque of the screwdriver so as not to damage the parts by countersinking the screw \*

Ferramentas necessárias  
Necessary tools  
Herramientas necesarias

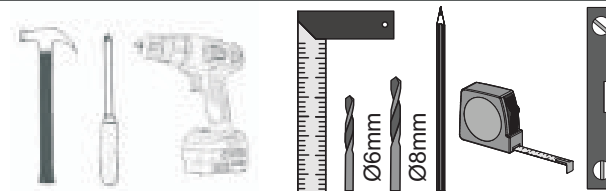

**ATENÇÃO!!!! montadores e consumidores**

\* Para limpar o móveis utilize somente um pano úmido (umedecido em água pura ou água com sabão neutro). Depois, passe um pano seco. Evite a umidade excessiva.

\* Evite usar álcool, água sanitária, detergente e outros produtos químicos, mesmo diluídos em água. Não utilize produtos abrasivos de nenhuma espécie

**ATENCIÓN!!!! montadores e consumidores**

\* Para limpiar el mueble utilice solamente un paño húmedo (humedecido con agua limpia o con un jabón suave).

\* Evite uso de alcohol, hipoclorídrico solución basada, detergente y otros productos químicos, mismo diluídos en agua. No utilice productos abrasivos de ningún tipo.

**ATTENTION!!!! assemblers and consumers**

\*To clean the furniture, use only a damp cloth (humidify it only in pure water ou water and neutral soap).After, use a dry cloth.Avoid excessive humidity.

\*Avoid using alcohol, bleach, detergent and other chemical products, even diluted in water. Do not use any kind of abrasive cleaning agents to clean the furniture.







The use of such products may jeopardize the final characteristics of the furniture.

# CO14400 - AÉREO 1,20 M

Manual de Montagem  
Assembly Instructions  
Instrucción de Montaje

decibal<sup>®</sup>  
móveis









## Ferragens/ Herrajes/ Hardware

		escala (1:1)	
LEGENDA	DESCRIÇÃO/DESCRIPCIÓN/DESCRIPTION	CÓDIGO	QUANT.
<b>P7</b>	 PARAFUSO/TORNILLO/SCREW 4X45	01318	<b>24</b>
<b>PR1</b>	 PREGO/CLAVO/NAIL 10X10	01330	<b>66</b>
<b>C2</b>	 CAVILHA/TARUGO/DOWEL 6X30 MM	01211	<b>26</b>
<b>P1</b>	 PARAFUSO/TORNILLO/SCREW 3,5X12	01328	<b>14</b>
<b>PU</b>	 PARAFUSO UNIÃO/UNIÓN DETORNILLO /SCREW UNION	01495	<b>02</b>
<b>P12</b>	 PARAFUSO/TORNILLO/SCREW 3,5X13	09927	<b>48</b>
<b>P9</b>	 PARAFUSO/TORNILLO/SCREW 6X50	03827	<b>06</b>

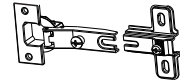
## escala (N/A)

LEGENDA	DESCRIÇÃO/DESCRIPCIÓN/DESCRIPTION	CÓDIGO	QUANT.
<b>R</b>	 2X      2X      6X ROLDANA CIV CORR C2 (1 PT)	07387	<b>01</b>

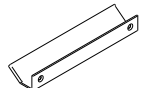
## escala (N/A)

LEGENDA	DESCRIÇÃO/DESCRIPCIÓN/DESCRIPTION	CÓDIGO	QUANT.
<b>CL</b>	 COLA/PEGAMENTO/GLUE	01213	<b>01</b>
<b>ET</b>	 ETIQUETA LOGO DECIBAL/LABEL DECIBAL	01312	<b>01</b>
<b>B1</b>	 BUCHA/BUJE/BUCHING ( 8mm)	01311	<b>06</b>
<b>DC</b>	 D      C DOBRADIÇA/BISAGRA/HINGE D=35mm C=Alta Amortecimento	12615	<b>06</b>
<b>S5</b>	 SUPORTE AÉREO/APOYO AÉREO/AIR SUPPORT	03828	<b>06</b>
<b>FX</b>	 FIXADOR COSTA/FIJADOR FONDO/FIXER COAST	01331	<b>08</b>
<b>AD</b>	ADESIVO/ADHESIVO/ADHESIVE 	15mm	<b>16</b>
<b>BT</b>	 BATENTE/BATIENTE DE SILICONA/SILICONE STOP 8MM	02921	<b>10</b>
<b>PX</b>	PUXADOR/PEGADOR /HANDLE CHAMPANHE( AKEO 128MM) 	12611	<b>03</b>
<b>TR</b>	 TRILHO/TRILLO/RAIL 1164mm	12631	<b>02</b>

Medida em mm

