

Aéreo 01 Porta Basculante 600mm Connect |
Aéreo 01 Puerta Basculante 600mm Connect |
01 air port Tipper 600mm Connect

- C77-35 - Duna/Cristal
- C77-42 - Fendi

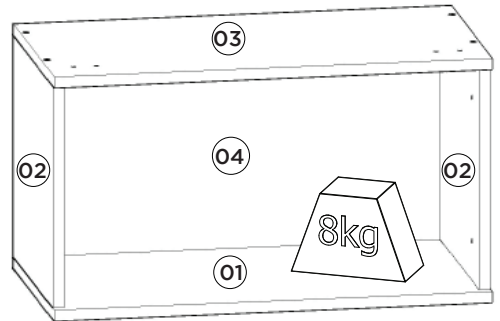
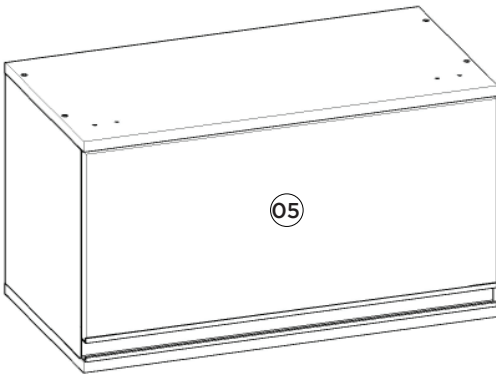

Pesos máximos recomendados com carga distribuída
Peso máximo recomendado con la carga distribuída
Recommended maximum weight with distributed load.

Requisitos para montagem
Requisitos para la montaje
Assembly Requirements

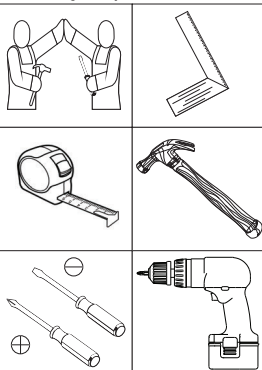

Imagens meramente ilustrativas
Imágenes meramente ilustrativas
Images for illustration only

AVISO

Para limpeza de seu móvel, use uma flanela seca ou umedecida, e não utilize produtos químicos que possam danificar seu produto.

SISTEMA DE MONTAGEM

O sistema de montagem dos produtos, funciona de acordo com a ordem crescente dos números indicados no desenho. Ex: 01, 02, 03, 04... até a conclusão da montagem.

ADVERTENCIA

Para limpieza de su móvil, use una flanela seca o húmeda, y no utilice productos químicos que puedan dañar su producto.

SISTEMA DE MONTAJE

El sistema de montaje de los productos funciona de acuerdo con el orden creciente de los números indicados en el dibujo. Ej.: 01, 02, 03, 04... hasta la conclusión del montaje.

NOTICE

To clean your furniture, use a dry or wet cloth, and do not use chemicals that may damage your product.

ASSEMBLY SYSTEM

The products' assembly system works according to the increasing order of the indicated numbers. For example: 01, 02, 03, 04 ... to the end of the assembly.

1º

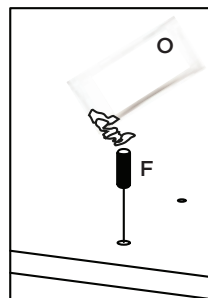
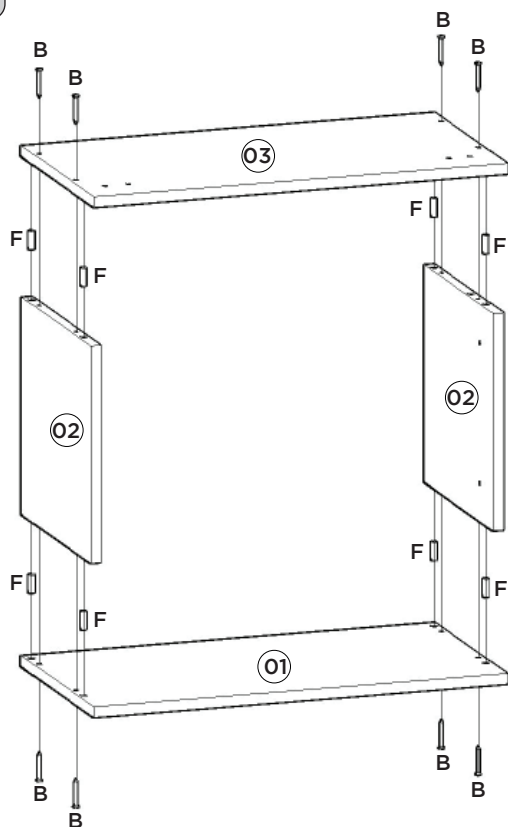

Utilizar o sachê de cola (O)
em todas as cavilhas (F)
do produto.

Con el pegamento sobre (O)
en todos los pernos (F)
producto.

Use the glue sachet (O) on all
the pegs (F) of the product.

2º

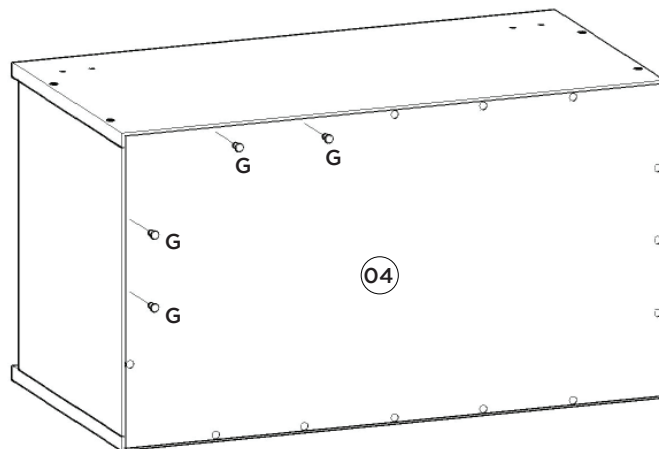

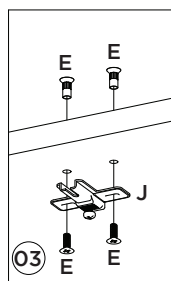
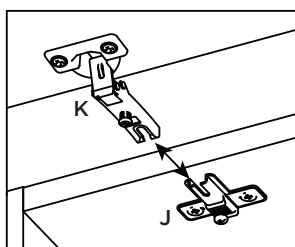
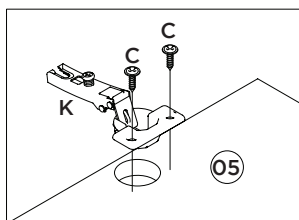
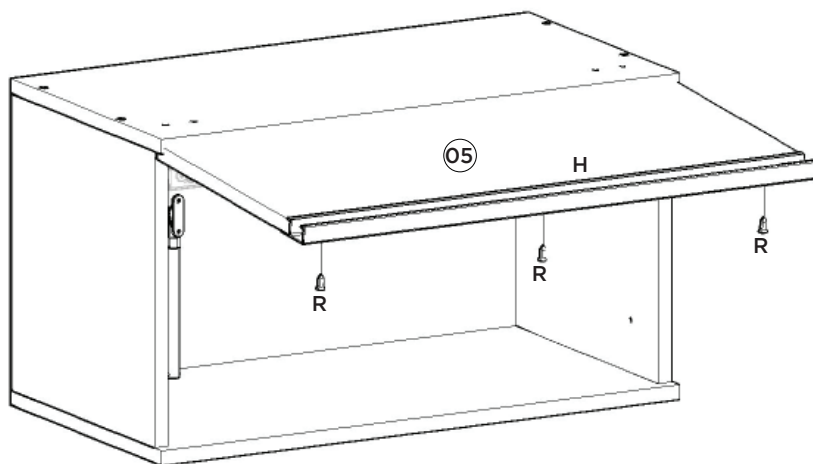

Vídeo: Instalar e regular Dobradiças

Vídeo: Instale y ajuste las bisagras

Vídeo: Install and adjust hinges



Vídeo: Dicas para instalar o Kit Pistão à Gás

Vídeo: Consejos para instalar el kit de pistón de gas



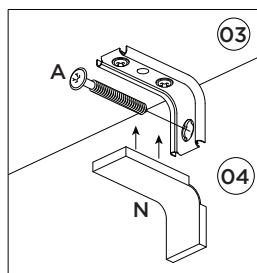
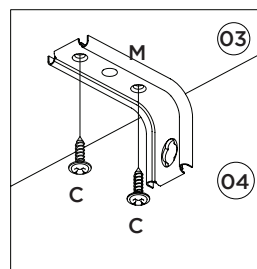
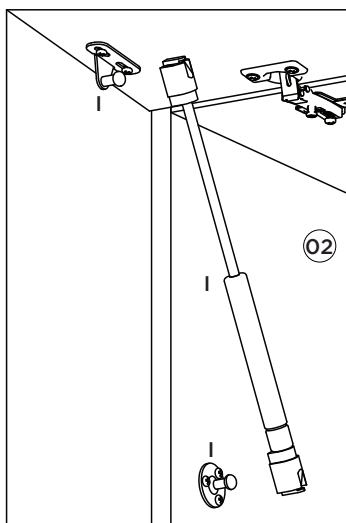
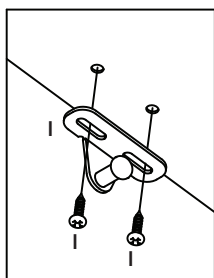
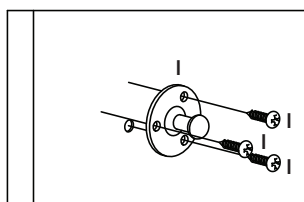









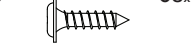

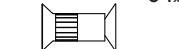

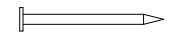
Vídeo: Tips for installing the Gas Piston Kit

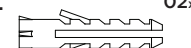

Lista de Peças | Lista de piezas | List of parts

Item	Caixa Caja Box	Qtd Ctd Qty	Descrição Descripción Description	Medidas (mm) Dimensions (mm) Size (measurements) (mm)
01	1/1	01	Base Base Base	600x310x15
02	1/1	02	Lateral Direita Esquerda Lateral Derecha Izquierda Right Side Left	307x295x15
03	1/1	01	Tampo Tapa Top	600x310x15
04	1/1	01	Fundo Fondo Bottom	592x331x3
05	1/1	01	Porta Basculante Puerta Basculante Basculating Door	595x274x15

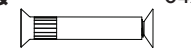
Ferragens | Herrajes | Hardware

A	02x	B	08x	C	08x	D	02x	E	04x
									
Parafuso 5,0x50mm FLA. Tornillo 5,0x50mm FLA. Screw 5,0x50mm FLA.		Parafuso 3,5x40mm CHT. Tornillo 3,5x40mm CHT. Screw 3,5x40mm CHT.		Parafuso 3,5x14mm FLA. Tornillo 3,5x14mm FLA. Screw 3,5x14mm FLA.		Batente PVC para Porta Parada de PVC para Puerta PVC Door Stop		Parafuso União 15mm Tornillo Unión 15mm Union Screw 15mm	
F	08x	G	16x	H	01x	I	01x	J	02x
									
Cavilha 8x25mm Cinta 8x25mm Dowel 8x25mm		Prego 10x10mm Clavo 10x10mm Nail 10x10mm		Puxador Alum. MOV 595mm Tirador Alum. MOV 595mm Handle Alum. MOV 595mm		Kit Pistão a Gás 60N Kit Pistón a Gas 60N 60N Gas Piston Kit		Calço metal Super Alto 8mm Calzado metálico Super Alto 8mm Super 8mm metal chock	
K	02x	L	02x	M	02x	N	02x	O	01x
									
Dobradiça metal 35mm Alta Bisagras metálicas 35mm Alta Metal hinge 35mm High		Bucha plástica 8mm Bucha de plástico 8mm 8mm plastic bushing		Suporte de fixação Soporte de fijación Mounting bracket		Proteção para cantoneira Ángulo de protección Protection angle		Sachê de cola Bolsa de pegamento Glue bag	
P	08x	Q	04x	R	03x				
									
Adesivo tapa parafuso 10mm Adhesivo tapón de tornillo 10mm Bolt cover adhesive 10mm		Parafuso União 30mm Tornillo Unión 30mm Union Screw 30mm		Parafuso 3,5x12mm CHT. Tornillo 3,5x12mm CHT. Screw 3,5x12mm CHT.					



O parafuso (Q) deve ser usada somente quando este módulo for acoplado a outro módulo componível Henn.



El tornillo (Q) se debe utilizar sólo cuando el módulo está conectado a otro módulo componible Henn.



The screw (Q) should be used only when this module is attached to another Henn modular module.

RECOMENDAÇÃO

Para fixar o móvel na parede usar o suporte de fixação (M), o parafuso 3,5x14mm FLA (C), a Bucha 8mm (L) e o parafuso 5,0x50mm FLA (A).

RECOMENDACIÓN

Para conectar el móvil a la pared con el soporte (M), tornillo 3,5 x14mm FLA (C), el casquillo de 8 mm (L) y el 5,0 x50mm tornillo FLA (A).

RECOMMENDATION

To fix the furniture to the wall use the fixing bracket (M), the 3.5x14mm FLA (C) screw, the 8mm bushing (L) and the 5.0x50mm FLA (A).