

kappesberg

A montagem deve ser efetuada por UMA pessoa.
El montaje debe ser efectuado por UNA persona.
The assembly must be done by ONE people.

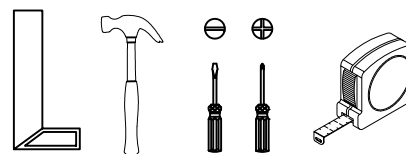

Ferramentas necessárias para montar o móvel
Herramientas necesarias para armar el mueble.
Tools needed to assemble the furniture.



Montar o móvel sobre uma superfície limpa e plana
Armar el mueble sobre una superficie limpia y plana
Assemble the furniture on a clean and flat surface

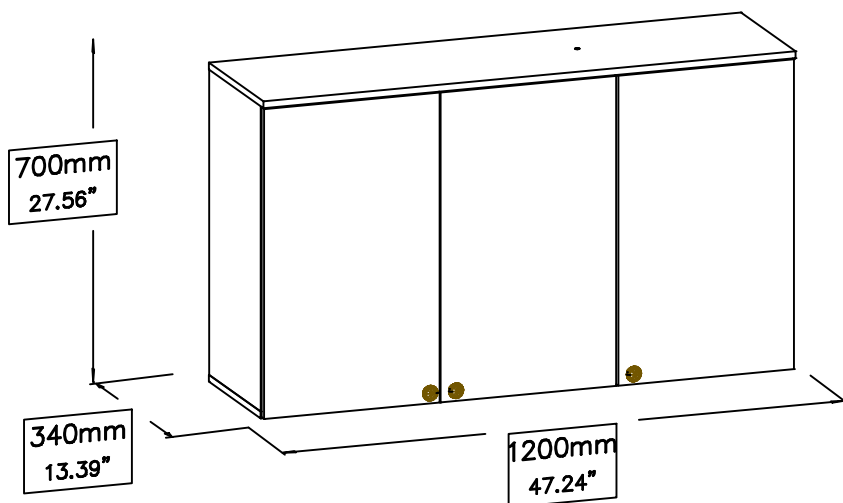
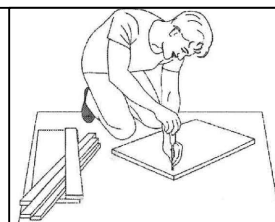

Lista de peças / Lista de piezas / List of pieces

Código / Code	Descrição	Descripción	Description	Quantidade / Cantidad / Amount	Comprimento / Longitud / Length (mm)	Comprimento / Longitud / Length (in.)	Largura / Ancho / Width (mm)	Largura / Ancho / Width (in.)	Espesura / Espesor / Thickness (mm)	Espesura / Espesor / Thickness (in.)	Caixa / Caja / Box
01	Lateral direita	Lateral derecha	Right side	1	670	26.38"	320	12.60"	15	.59"	A
02	Lateral esquerda	Lateral izquierda	Left side	1	670	26.38"	320	12.60"	15	.59"	A
03	Divisória	División	Division	1	670	26.38"	320	12.60"	15	.59"	A
04	Prateleiras maior	Estanterías mayor	Larger Shelf	1	769	30.28"	320	12.60"	15	.59"	A
05	Prateleiras menor	Estanterías pequeña	Smaller shelf	1	385	15.16"	320	12.60"	15	.59"	A
06	Base	Pieza de suelo	Base	1	1200	47.24"	320	12.60"	15	.59"	A
07	Chapéu	Pieza de techo	Top	1	1200	47.24"	338	13.31"	15	.59"	A
08	Porta	Puerta	Door	3	680	26.77"	396	15.59"	15	.59"	A
09	Peça de acabamento			2	326	12.83"	100	3.94"	25	.98"	A
10	Costa	Pieza del fondo	Back panel	2	1190	46.85"	345	13.58"	3	.12"	A

IDENTIFICAÇÃO DAS PEÇAS/ IDENTIFICACIÓN DE LAS PIEZAS/ PARTS IDENTIFICATION

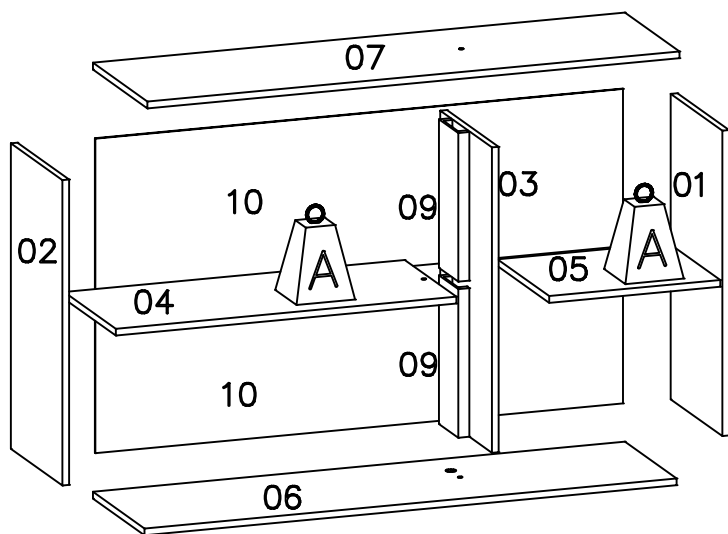
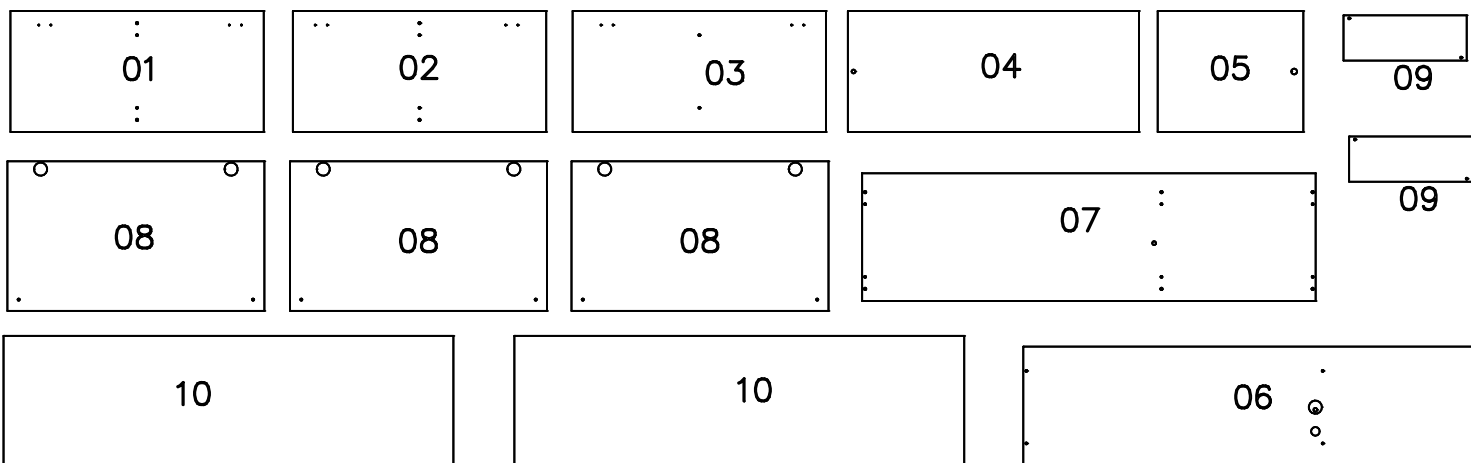

Duvidas? entrar em contato:

¿Dudas? Ponerse en contacto:

Doubts? Get in touch:

Fone: (51) 3635-8839
www.kappesberg.com.br

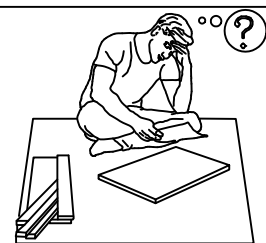

	Kg	lb
A	7	15.43lb

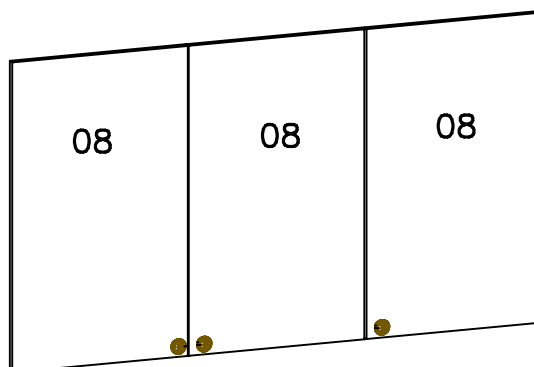

Em caso de dúvida, compare as ferragens com as imagens no decorrer do manual.

En caso de duda, compare el hardware con las imágenes del manual.

If in doubt, compare the hardware with the images throughout the manual

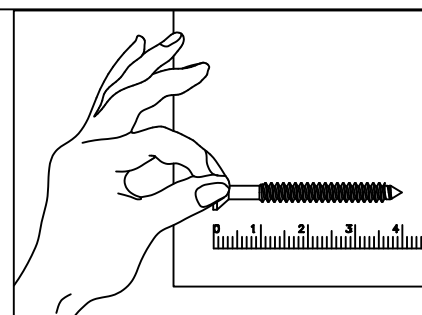

IDENTIFICAÇÃO DOS ACESSÓRIOS/ IDENTIFICACIÓN DE ACCESORIOS/ IDENTIFICATION OF ACCESSORIES



–NOTAS: A separação dos acessórios antes de iniciar a montagem facilitará a mesma. Os parafusos e cavilhas estão na escala real. Em caso de dúvida na identificação, coloque o acessório sobre a imagem.

–NOTAS:La separación de los accesorios antes de comenzar el armado facilitará el mismo. Los tornillos y taquetes son en escala real. En caso de dudas sobre la identificación, coloque el accesorio en la imagen.

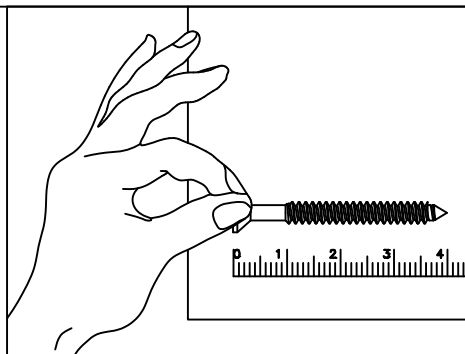
–NOTES:The separation of the accessories before you start the assembly will facilitate the same. The screws and dowels are in real scale. In case of doubts about the identification, place the accessory on the image

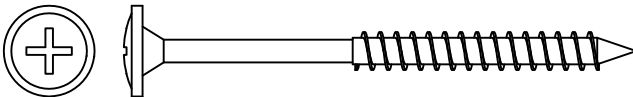
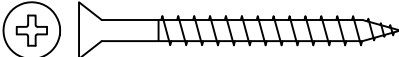
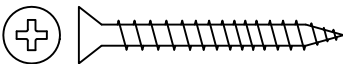
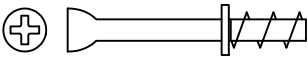
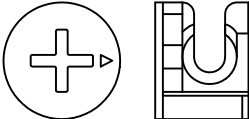
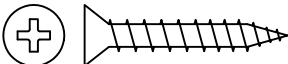

Ferragem / Herrajes / Hardware

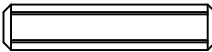
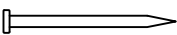
	Código/ Código/ Code	Descrição / Descripción / Description	Quan./ Cant./ Amou.
PF9	50311	 Parafuso flangeado/ Tornillo de cabeza flangead/ Flanged head screw 5,0x65mm	4
PC8	226	 Parafuso chato/ Tornillo de cabeza plana/ Flat head screw 4x40mm	18
PC7	10568	 Parafuso/ Tornillo/ Screw 4x35	4
PM	30945	 Parafuso Minifix/ Tornillo/Connecting Bolt	1
TM	30950	 Tambor Minifix/Cilindro/Minifix Cam	1
PC4	54117	 Parafuso chato/ Tornillo de cabeza plana/ Flat head screw 3,5x25mm	5
PC3	4214	 Parafuso chato/ Tornillo de cabeza plana/ Flat head screw 3,5x14mm	8
C2	1925	 Cavilha/Tarugo/Dowel 6x50mm	2
C1	1802	 Cavilha/ Pin/ Wooden Dowel 6x30mm	16
PR1	107	 Prego/Clavo/Nail 10x10mm	50

Prezado Montador:

– Antes de iniciar a montagem verifique as condições do ambiente de montagem;
– Confira todas as peças das embalagens com a lista de peças contida neste manual;
– Separe os acessórios, confira as medidas dos parafusos com a escala;
– Siga todas as orientações deste manual de montagem para ter o direito à garantia do produto;
– Descarte as embalagens de forma correta, destinando o plástico e o papel para reciclagem;

Estimado Montador:







– Antes de iniciar a montagem verifique as condições do ambiente de montagem;
– Confira todas as peças das embalagens com una lista de peças contida neste manual;
– Separe os acessórios, confira as medidas dos parafusos com a escala;
– Siga todas las orientaciones deste manual de montagem para ter o direito à garantia do produto;
– Descarte como embalagens de forma correta, destinando o plástico e o papel para reciclagem;

Dear Fitter:

– Before starting montagem check as conditions of the assembly environment;
– Check out all the packaging com a list of fish contained in this manual;
– Separate the accessories, check the measures two parafuses com to scale;
– Follow all the guidelines of this manual montagem for ter or direct to guarantee of the product;
– Discard the packages correctly, allocating either plastic or paper for recycling;



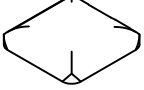
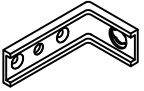
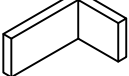
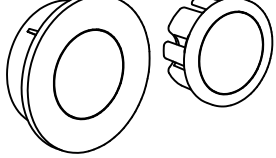
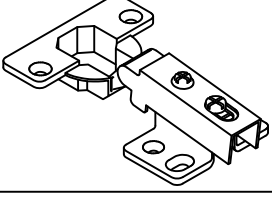
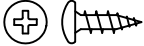

Ferragem / Herrajes / Hardware

	Código/ Código/ Code	Descrição / Descripción / Description	Quan./ Cant./ Amou.
CB	41	 Cola branca em bolsa/Cola blanca/White glue	1
PX	63109	 Puxador/Asar/Handle	3
BC	529	 Bucha invasa/Adapter sleeve/ Manga del adaptador	4
FC	1423	 Fixador de costa/Fijador de costa/Shore Fixer	12
EM	58	 Etiqueta marca/Tag label "Kappesberg"	1
TP2	NG=63102 (Nogueira)	 Tapa furo/Tapa del agujero/Screw cap cover 13mm	22
GS	40534	 Silicone/Silicona/ Selecone	3
S10	17024	 Suporte aéreo/Suporte de seguridad/Safety bracket	4
CS	6959	 Capa para suporte /Cubierta de soporte/Support cover	4
LED	64830	 Kit led/LED kit	1
DO11	51322	 Dobradiça reta calço fixo e amortecedor/Bisagra/ Hinge 35mm	6
	61971	 Parafuso da dobradiça/ Tornillo del bisagra/Hinge Screw 4,0x14	36



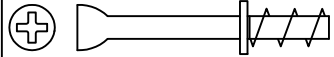

PRÉ-MONTAGEM/ PRE-ASSEMBLE/ PRE ARMADO

01 PASSO/ PASO/ STEP

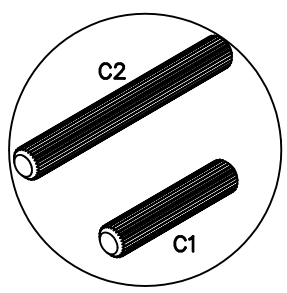
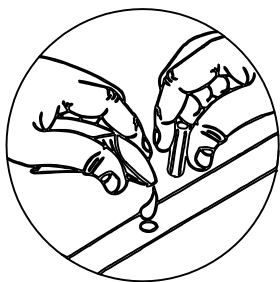
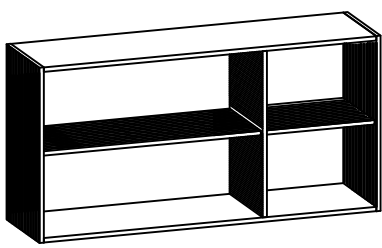
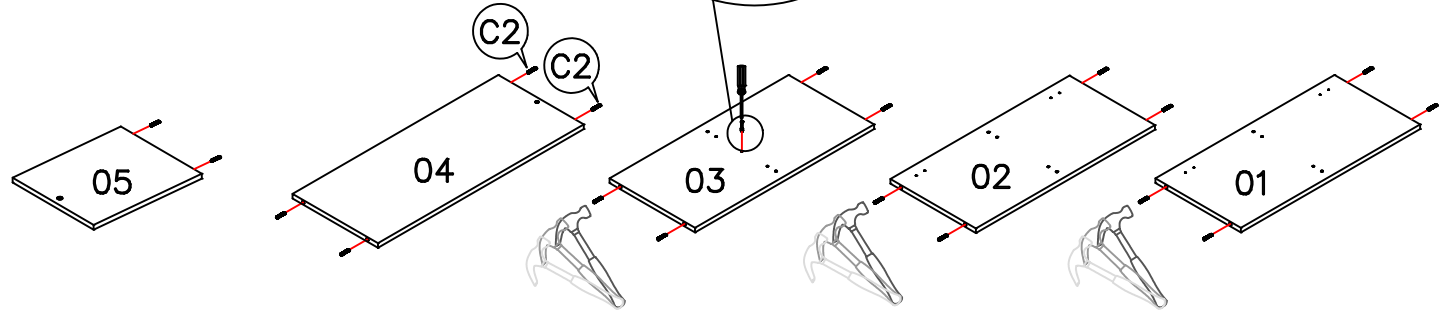
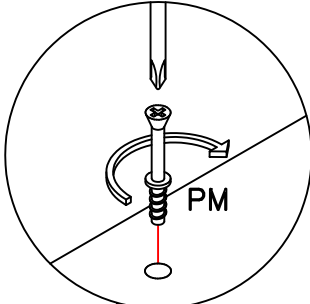
C2		2
C1		16
PM		1

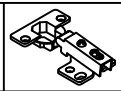

02 PASSO/ PASO/ STEP

DO11		6
DO11		12

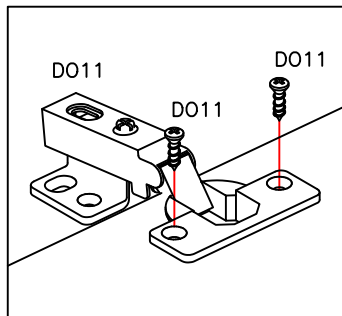

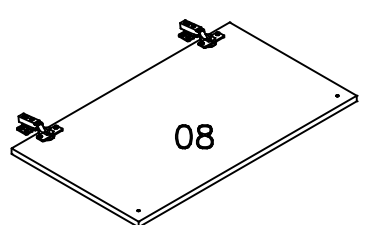
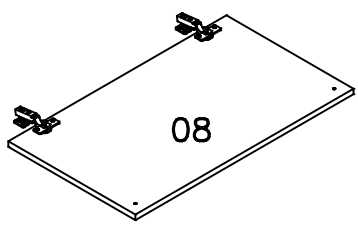
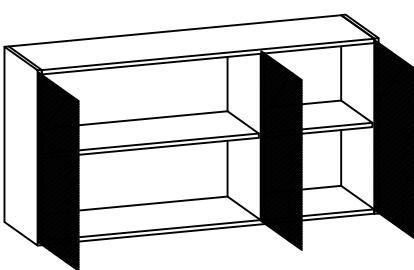
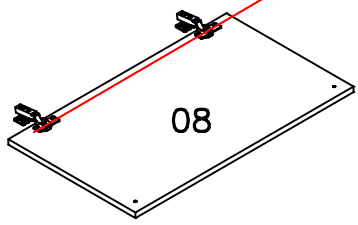

 -ATENÇÃO PARA O ALINHAMENTO DAS DOBRADIÇAS
 -ATENCIÓN PARA ALINEAR LAS BISAGRAS
 -ATTENTION TO THE ALIGNMENT OF THE HINGES

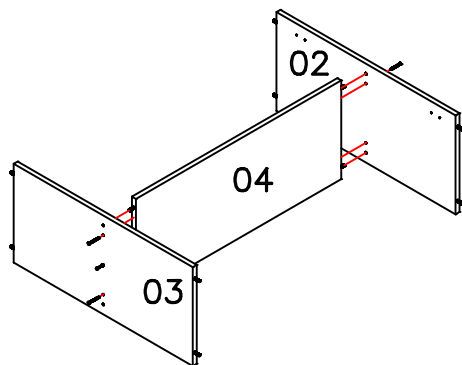

MONTAGEM/ ASSEMBLE/ ARMADO

03 PASSO/ PASO/ STEP



PC8		4
TP2		2

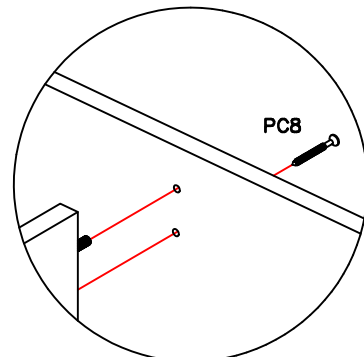
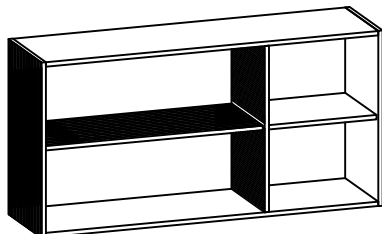

04 PASSO/ PASO/ STEP

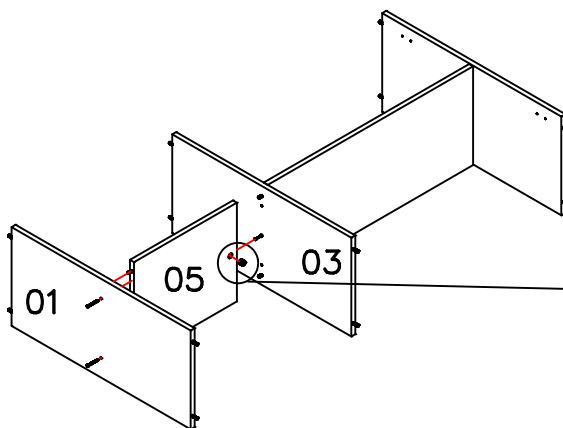
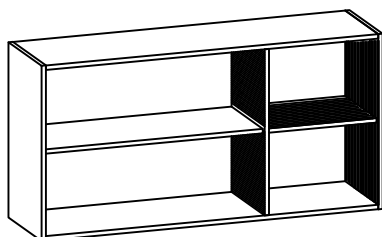
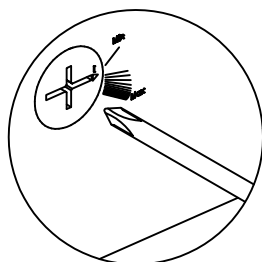

PC8		2
TP2		2
TM		1

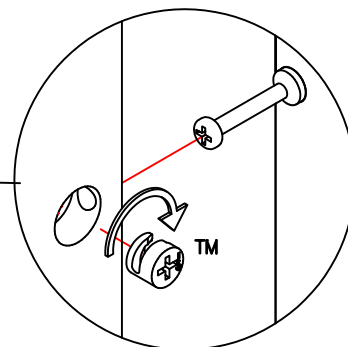

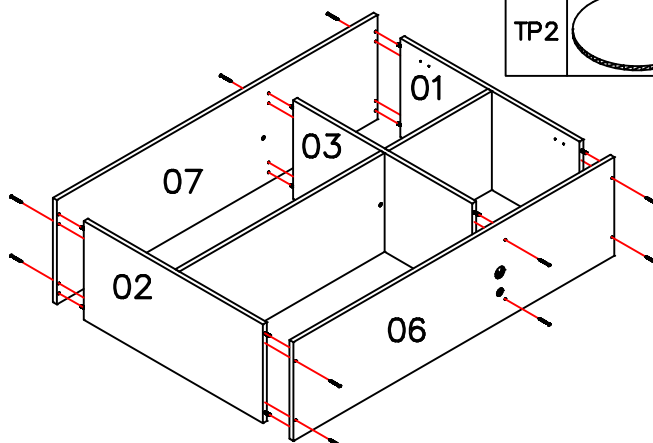
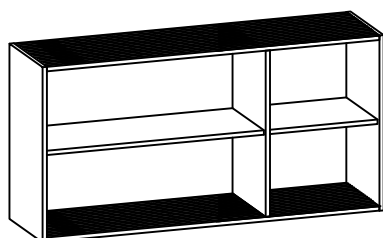

05 PASSO/ PASO/ STEP

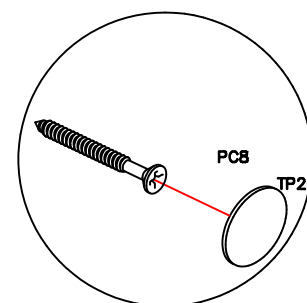

PC8		12
TP2		12

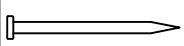

06 PASSO/ PASO/ STEP

PR1		50
FC		12

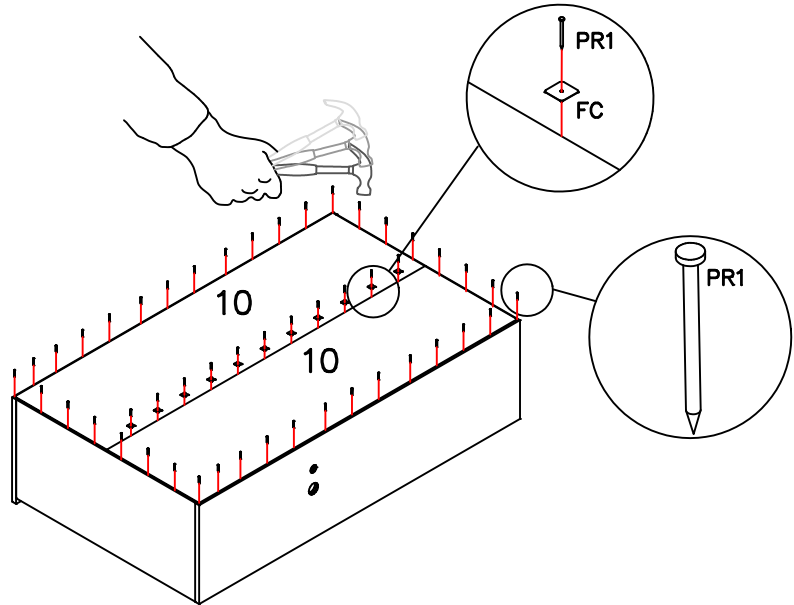
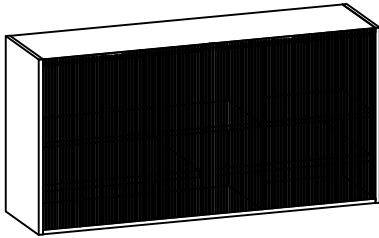

07 PASSO/ PASO/ STEP

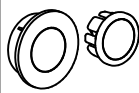
LED		1
-----	---	---

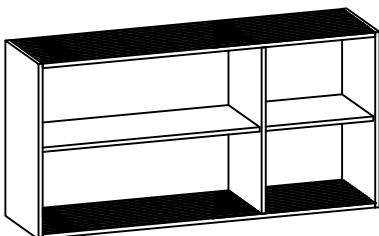
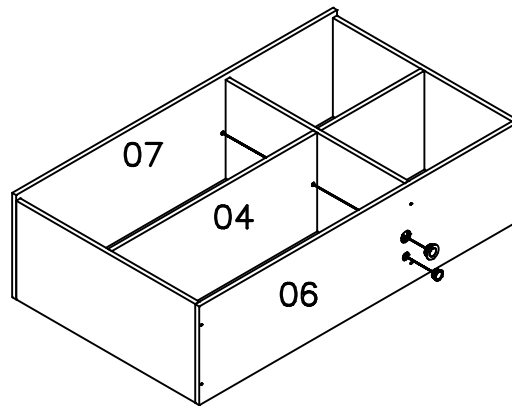

08 PASSO/ PASO/ STEP

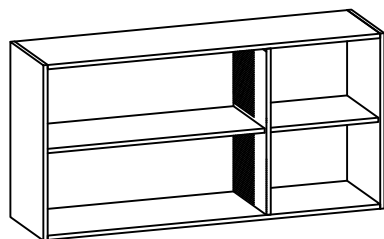
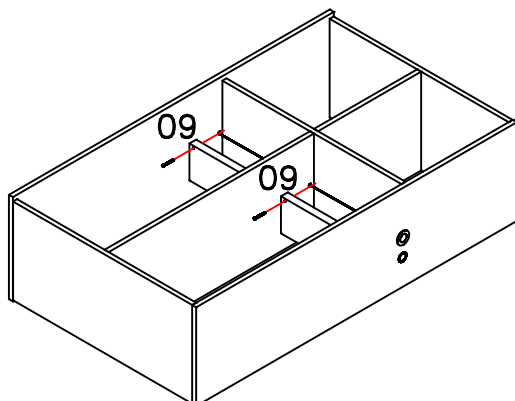

PC7		4
TP2		4

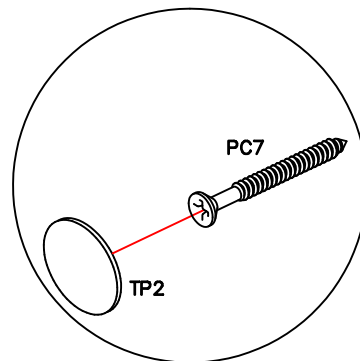

09 PASSO/ PASO/ STEP

NOTA: Utilize o furo oblongo para posicionar a altura da dobradiça. E por fim quando a porta estiver posicionada de maneira correta utilize o furo circular para garantir que a mesma não se desloque.

NOTAS: Utilice o furo oblongo para posicionar a altura da dobradiça. E por fim quando a porta estiver posicionada de maneira correta utilize o furo circular para garantir que a mesma não se desloque.

NOTE: Use the oblong edge to position at the height of the dobradiça. And for this reason, when the estiver holder is positioned in a correct way, use a circular hole to ensure that it does not loosen at the same time.

DO11		24
PC4		3
PX		3
GS		3

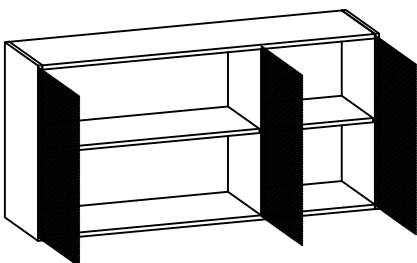
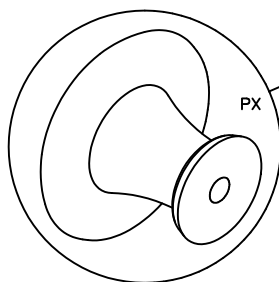
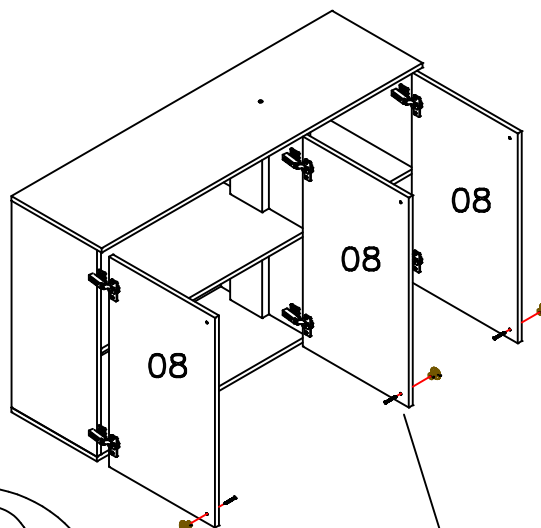
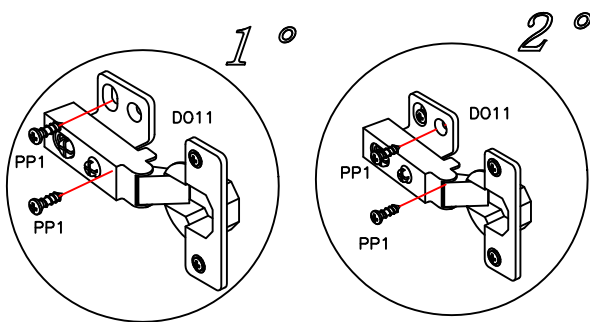

GS

- As batentes de silicone "GS" são colocadas na porta, para suavizar eventuais impactos.
- Los toques de silicona "GS" se colocan en la puerta, para suavizar los impactos.
- The silicone stops "GS" are placed on the door, to soften any impacts.

10 AJUSTE DE PORTAS/ AJUSTE DE PUERTA/ DOORS ADJUSTMENT

REGULAGEM VERTICAL/ AJUSTE VERTICAL/ VERTICAL ADJUSTMENT

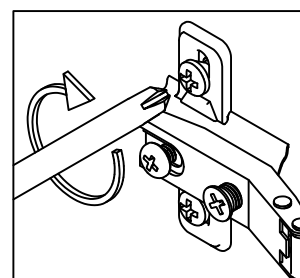
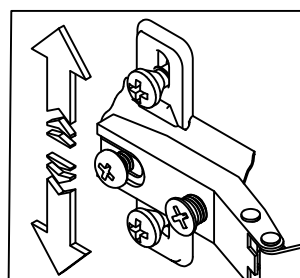
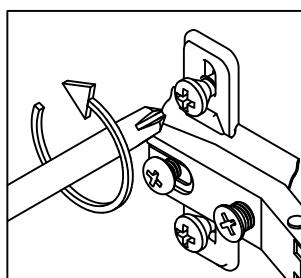
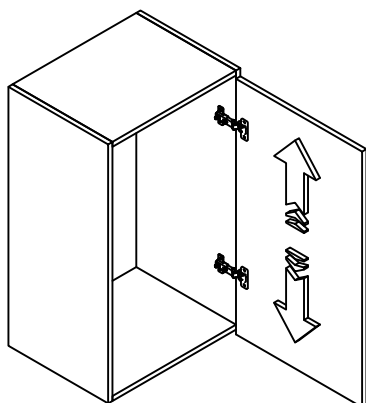



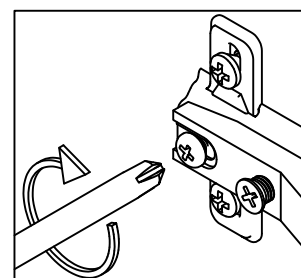
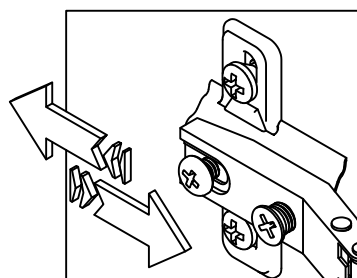
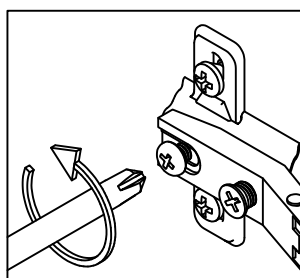
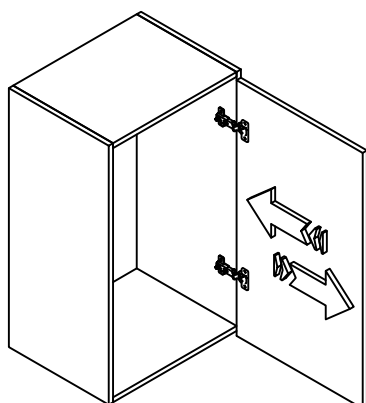



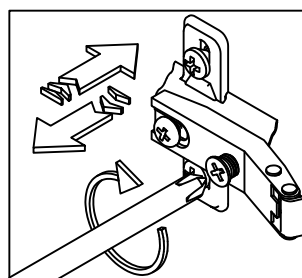
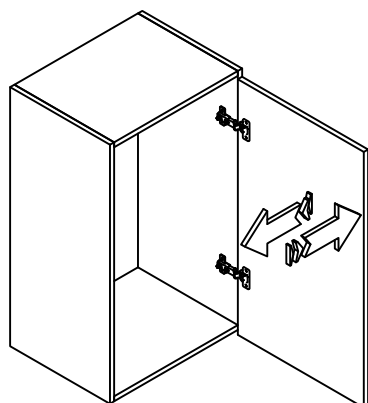

REGULAGEM PROFUNDIDADE/ AJUSTE PROFUNDIDAD/ DEPTH ADJUSTMENT

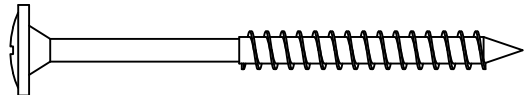

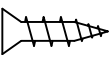

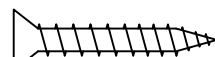

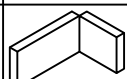
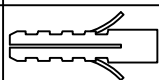
REGULAGEM HORIZONTAL/ AJUSTE HORIZONTAL/ HORIZONTAL ADJUSTMENT

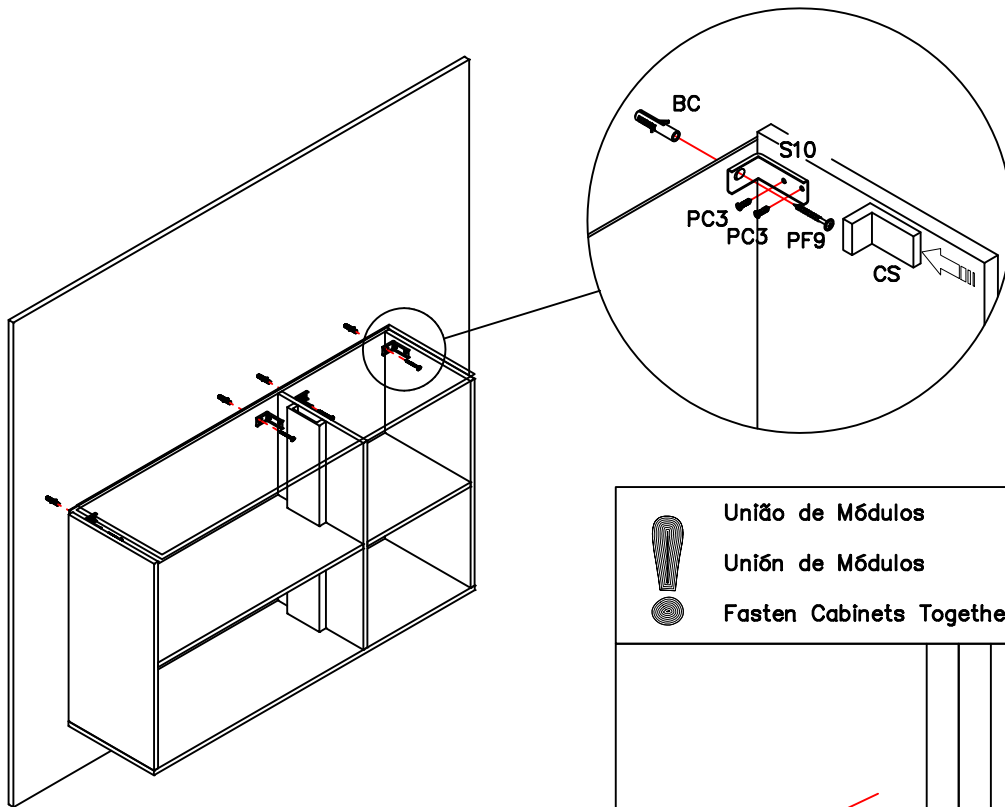

11 PASSO/ PASO/ STEP

PF9			4
PC3			8
PC4			2
S10			4
CS			4
BC			4
TP2			2



	União de Módulos
	Unión de Módulos
	Fasten Cabinets Together

