

kappesberg

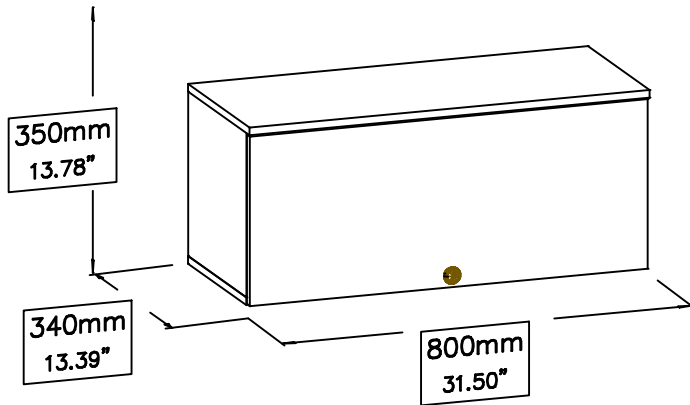

A montagem deve ser efetuada por UMA pessoa.
El montaje debe ser efectuado por UNA persona.
The assembly must be done by ONE people.

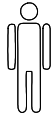

Ferramentas necessárias para montar o móvel
Herramientas necesarias para armar el mueble.
Tools needed to assemble the furniture.

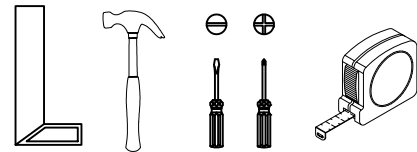

Montar o móvel sobre uma superfície limpa e plana
Armar el mueble sobre una superficie limpia y plana
Assemble the furniture on a clean and flat surface

Y:\Pastas pessoais\Rudimar\Capturar 2.PNG

Lista de peças / Lista de piezas / List of pieces

Código / Code	Descrição	Descripción	Description	Quantidade / Cantidad / Amount	Comprimento / Longitud / Length (mm)	Comprimento / Longitud / Length (In.)	Largura / Ancho / Width (mm)	Largura / Ancho / Width (In.)	Espessura / Espesor / Thickness (mm)	Espessura / Espesor / Thickness (In.)	Caixa / Caja / Box
01	Lateral direita	Lateral derecha	Right side	1	320	12.60"	320	12.60"	15	.59"	A
02	Lateral esquerda	Lateral izquierda	Left side	1	320	12.60"	320	12.60"	15	.59"	A
03	Base	Pieza de suelo	Base	1	800	31.50"	320	12.60"	15	.59"	A
04	Chapéu	Pieza de techo	Top	1	800	31.50"	338	13.31"	15	.59"	A
05	Porta	Puerta	Door	1	795	31.30"	330	12.99"	15	.59"	A
06	Costa	Pieza del fondo	Back panel	1	790	31.10"	345	13.58"	3	.12"	A

IDENTIFICAÇÃO DAS PEÇAS/ IDENTIFICACIÓN DE LAS PIEZAS/ PARTS IDENTIFICATION

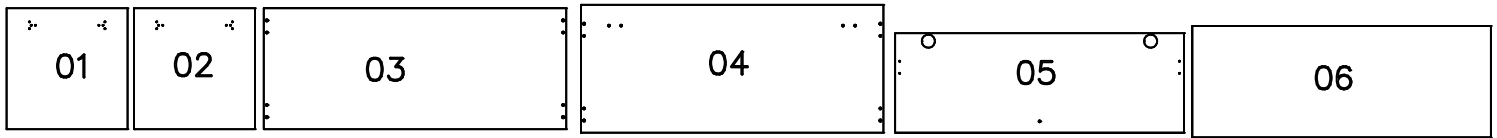

Dúvidas? entrar em contato:
¿Dudas? Ponerse en contacto:
Doubts? Get in touch:

Fone: (51) 3635-8839
www.kappesberg.com.br

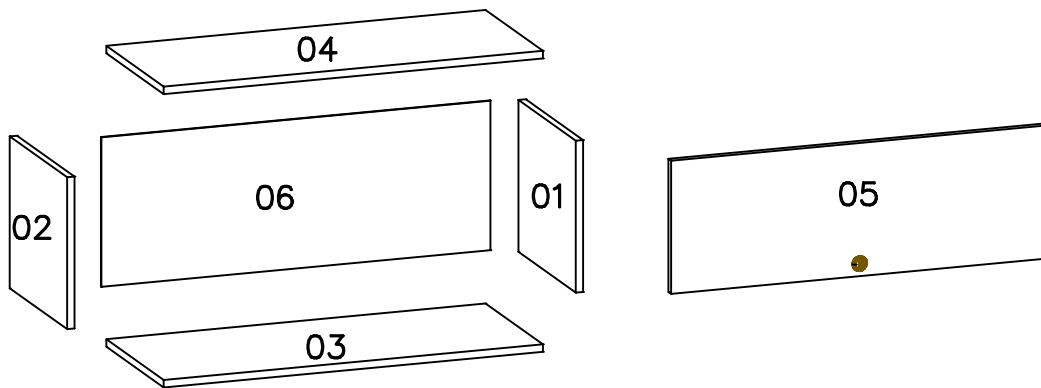
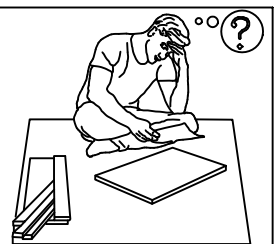

Em caso de dúvida, compare as ferragens com as imagens no decorrer do manual.

En caso de duda, compare el hardware con las imágenes del manual.

If in doubt, compare the hardware with the images throughout the manual

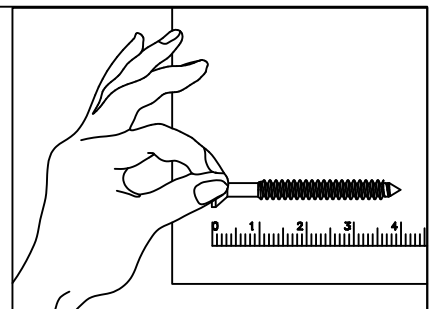

IDENTIFICAÇÃO DOS ACESSÓRIOS/ IDENTIFICACIÓN DE ACCESORIOS/ IDENTIFICATION OF ACCESSORIES



–NOTAS: A separação dos acessórios antes de iniciar a montagem facilitará a mesma. Os parafusos e cavilhas estão na escala real. Em caso de dúvida na identificação, coloque o acessório sobre a imagem.

–NOTAS:La separación de los accesorios antes de comenzar el armado facilitará el mismo. Los tornillos y taquetes son en escala real. En caso de dudas sobre la identificación, coloque el accesorio en la imagen.

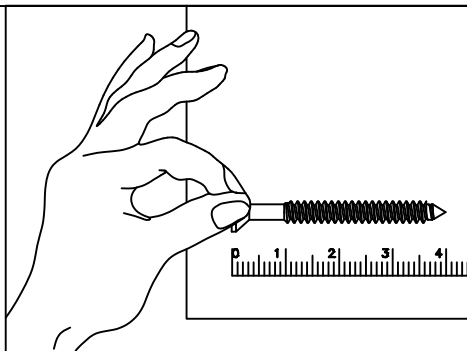
–NOTES:The separation of the accessories before you start the assembly will facilitate the same. The screws and dowels are in real scale. In case of doubts about the identification, place the accessory on the image

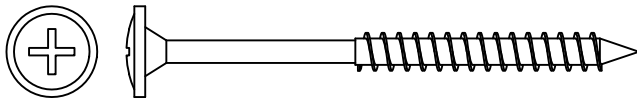
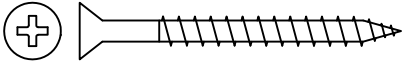
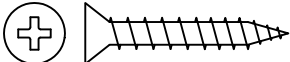

Ferragem / Herrajes / Hardware

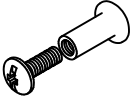
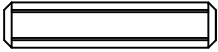
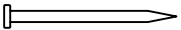
	Código/ Código/ Code	Descrição / Descripción / Description	Quan./ Cant./ Amou.
PF9	50311	 Parafuso flangeado/ Tornillo de cabeza flangead/ Flanged head screw 5,0x65mm	2
PC8	226	 Parafuso chato/ Tornillo de cabeza plana/ Flat head screw 4x40mm	8
PC4	54117	 Parafuso chato/ Tornillo de cabeza plana/ Flat head screw 3,5x25mm	3
PC3	4214	 Parafuso chato/ Tornillo de cabeza plana/ Flat head screw 3,5x14mm	12
PU	8688	 Parafuso união metálico/Tornillo de unión de metal/ Metal union bolt	4
C1	1802	 Cavilha/ Pin/ Wooden Dowel 6x30mm	8
PR1	107	 Prego/Clavo/Nail 10x10mm	23

Prezado Montador:

– Antes de iniciar a montagem verifique as condições do ambiente de montagem;
– Confira todas as peças das embalagens com a lista de peças contida neste manual;
– Separe os acessórios, confira as medidas dos parafusos com a escala;
– Siga todas as orientações deste manual de montagem para ter o direito à garantia do produto;
– Descarte as embalagens de forma correta, destinando o plástico e o papel para reciclagem;











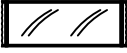

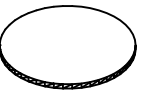
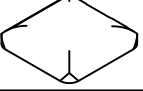

Estimado Montador:

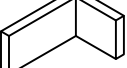
– Antes de iniciar a montagem verifique as condições do ambiente de montagem;
– Confira todas as peças das embalagens com a lista de peças contida neste manual;
– Separe os acessórios, confira as medidas dos parafusos com a escala;
– Siga todas las orientaciones deste manual de montagem para ter o direito à garantia do produto;
– Descarte como embalagens de forma correta, destinando o plástico e o papel para reciclagem;

Dear Fitter:

– Before starting montagem check as conditions of the assembly environment;
– Check out all the packaging com a list of fish contained in this manual;
– Separate the accessories, check the measures two parafuses com to scale;
– Follow all the guidelines of this manual montagem for ter or direct to guarantee of the product;
– Discard the packages correctly, allocating either plastic or paper for recycling;



Ferragem / Herrajes / Hardware			
	Código/ Código/ Code	Descrição / Descripción / Description	Quan./ Cant./ Amou.
CB	41	 Cola branca em bispnaga/Cola blanca/White glue	1
PX	63109	 Puxador/Asar/Handle	1
CG	899	 Cantoneira/Cantón /Angle bracket	2
BC	529	 Bucha invasa/Adapter sleeve/ Manga del adaptador	2
EM	58	 Etiqueta marca/Tag label "Kappesberg"	1
TP2	NG=63102 (Nogueira)	 Tapa furo/Tapa del agujero/Screw cap cover 13mm	6
GS	40534	 Silicone/Silicona/ Selecone	2
S10	17024	 Suporte aéreo/Soporte de seguridad/Safety bracket	2
CS	6959	 Capa para suporte /Cubierta de soporte/Support cover	2
DOB	61969	 Dobradiça super curva/Bisagra/Hinge 35mm	2
	62435	 Calço para dobradiça/ Bisagra de calce/ Hinge shim	2
	61971	 Parafuso da dobradiça/ Tornillo del bisagra/Hinge Screw 4,0x14	4
PG3A	35154	 Pistão a gás/Pistón de gas/Gas piston 60N	1
PG3B			1
PG3C			1
PG3D		 Parafuso/ Tornillo/ Screw	5



PRÉ-MONTAGEM/ PRE-ASSEMBLE/ PRE ARMADO

01 PASSO/ PASO/ STEP

C1		8
----	---	---

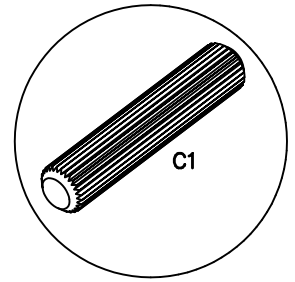
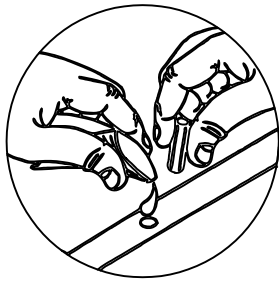
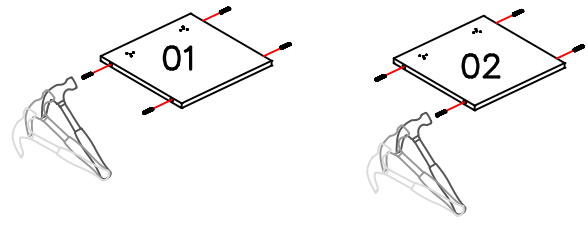

02 PASSO/ PASO/ STEP

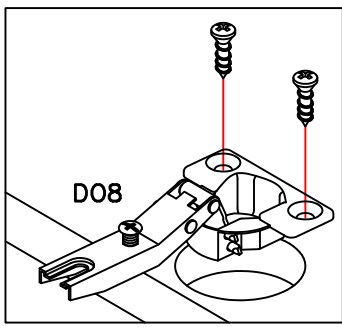

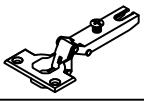
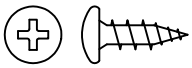

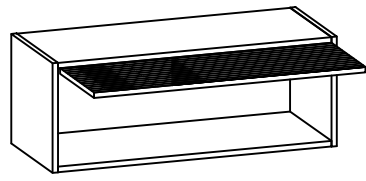
D08		2
D08		4

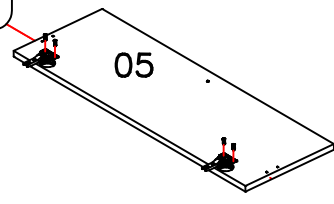

-ATENÇÃO PARA O ALINHAMENTO DAS DOBRADIÇAS
-ATENCIÓN PARA ALINEAR LAS BISAGRAS
-ATTENTION TO THE ALIGNMENT OF THE HINGES



03 PASSO/ PASO/ STEP

D08		2
PU		4

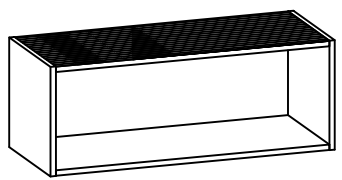
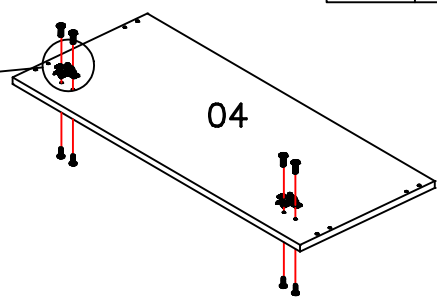
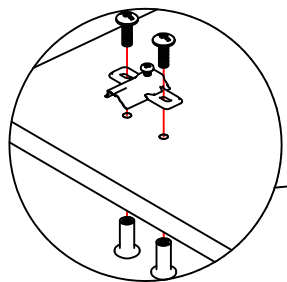

MONTAGEM/ ASSEMBLE/ ARMADO

04 PASSO/ PASO/ STEP

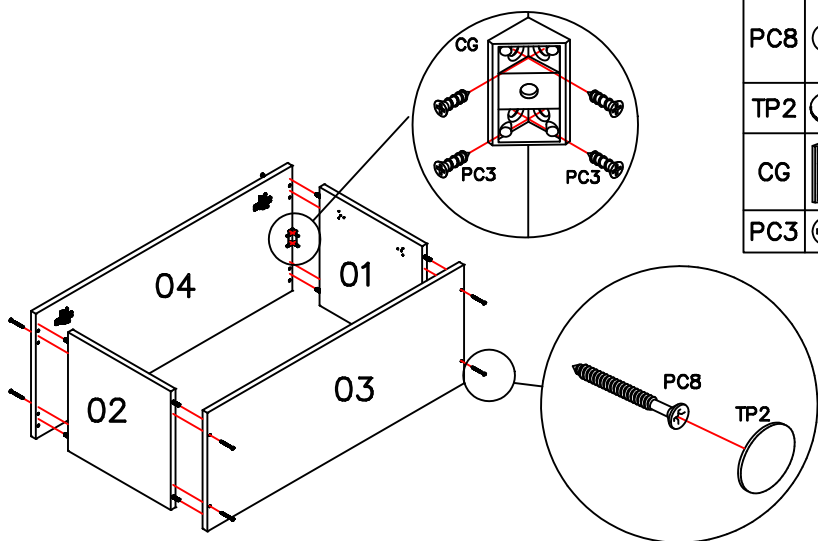
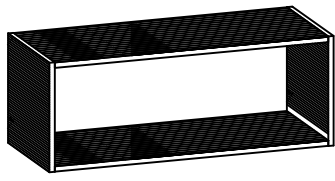

PC8		8
TP2		4
CG		2
PC3		8

05 PASSO/ PASO/ STEP

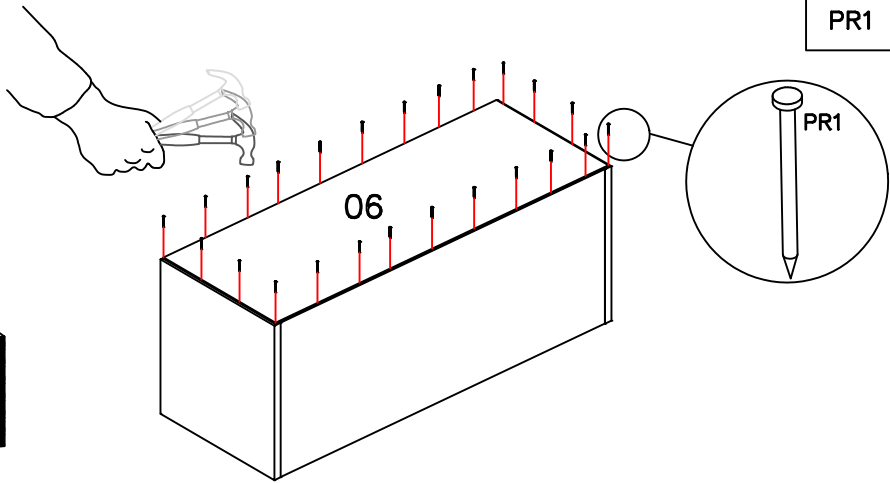
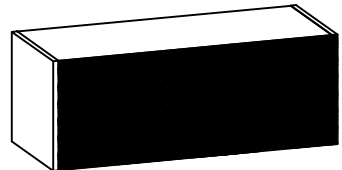

PR1		23
-----	--	----

06 PASSO/ PASO/ STEP

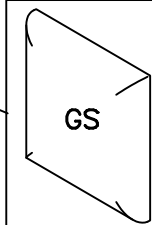
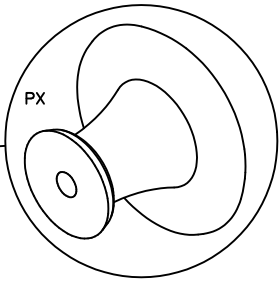
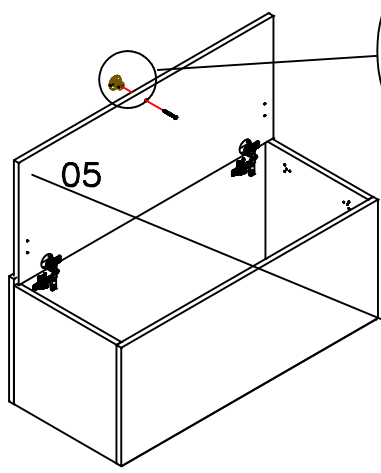

-As batentes de silicone "GS" são colocadas na porta, para suavizar eventuais impactos.
 -Los topes de silicona "GS" se colocan en la puerta, para suavizar los impactos.
 -The silicone stops "GS" are placed on the door, to soften any impacts.

PC4		1
PX		1
GS		2

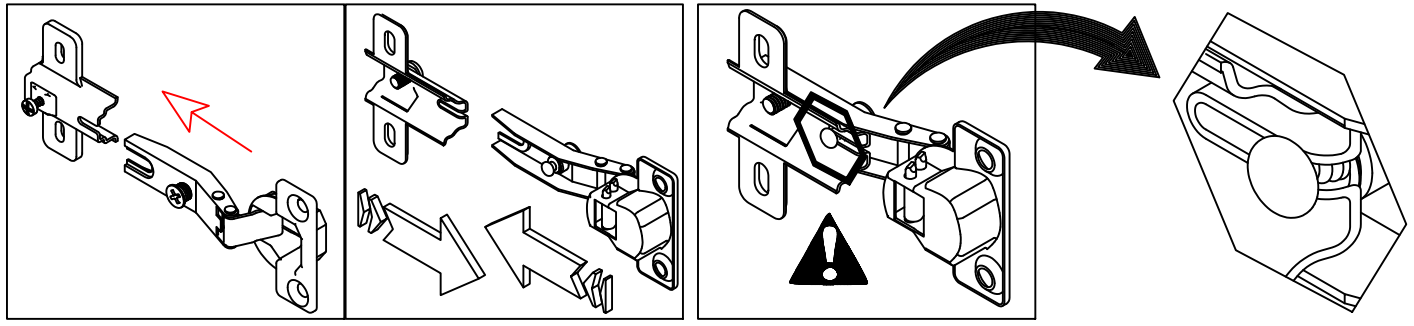

07 PASSO/ PASO/ STEP

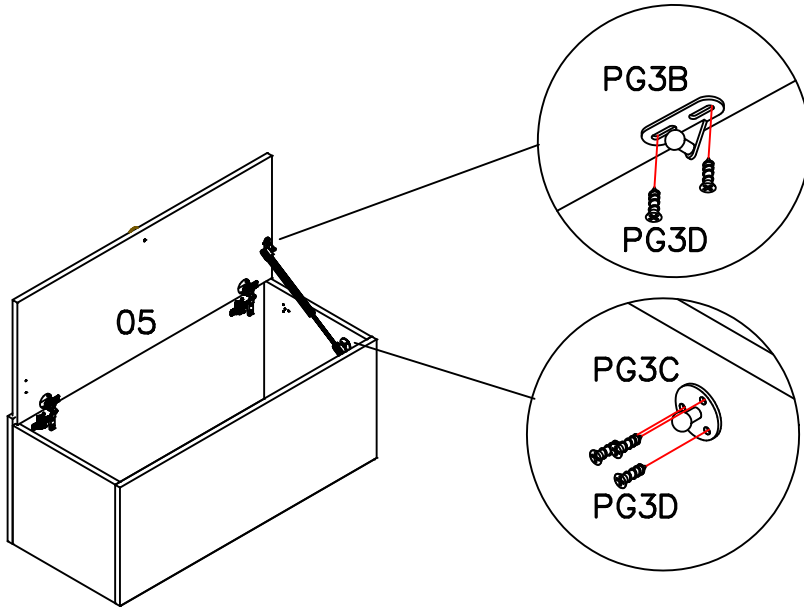

PG3A		1
PG3B		1
PG3C		1
PG3D		5

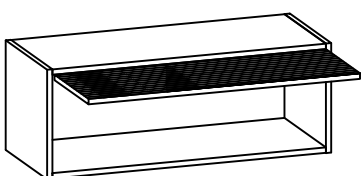
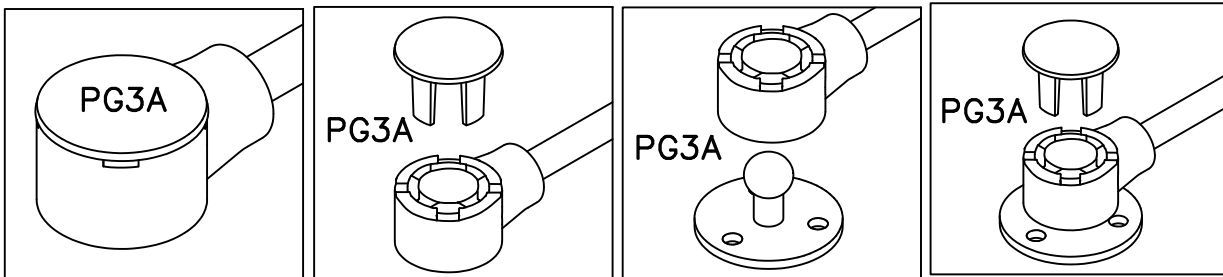

09 AJUSTE DE PORTAS/ AJUSTE DE PUERTA/ DOORS ADJUSTMENT

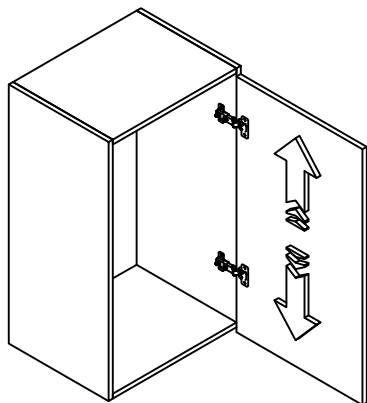

REGULAGEM VERTICAL/ AJUSTE VERTICAL/ VERTICAL ADJUSTMENT

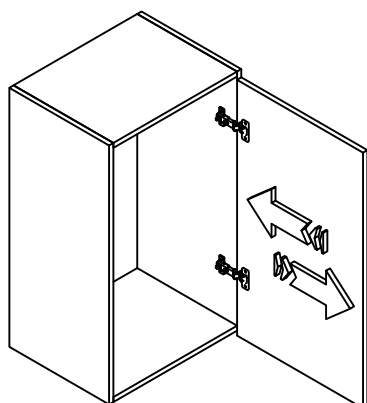
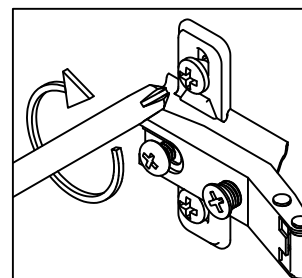
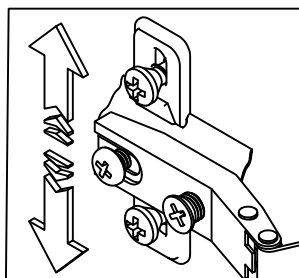
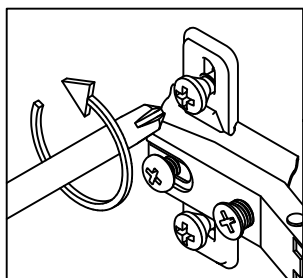



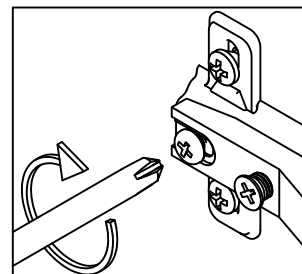
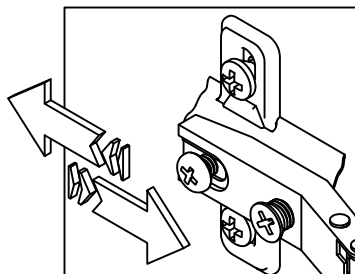
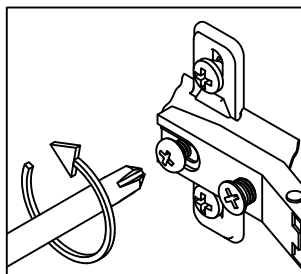



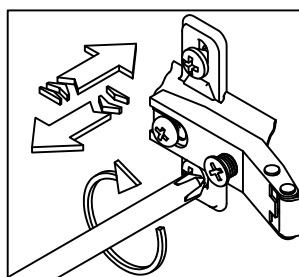
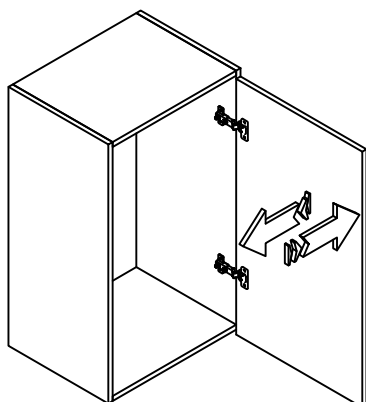

REGULAGEM PROFUNDIDADE/ AJUSTE PROFUNDIDAD/ DEPTH ADJUSTMENT

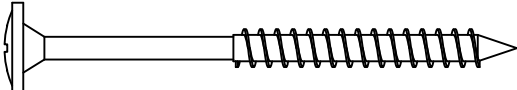

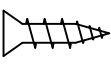

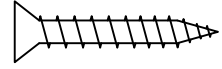

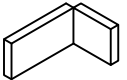
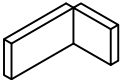
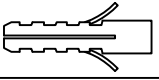
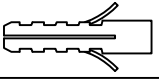
REGULAGEM HORIZONTAL/ AJUSTE HORIZONTAL/ HORIZONTAL ADJUSTMENT

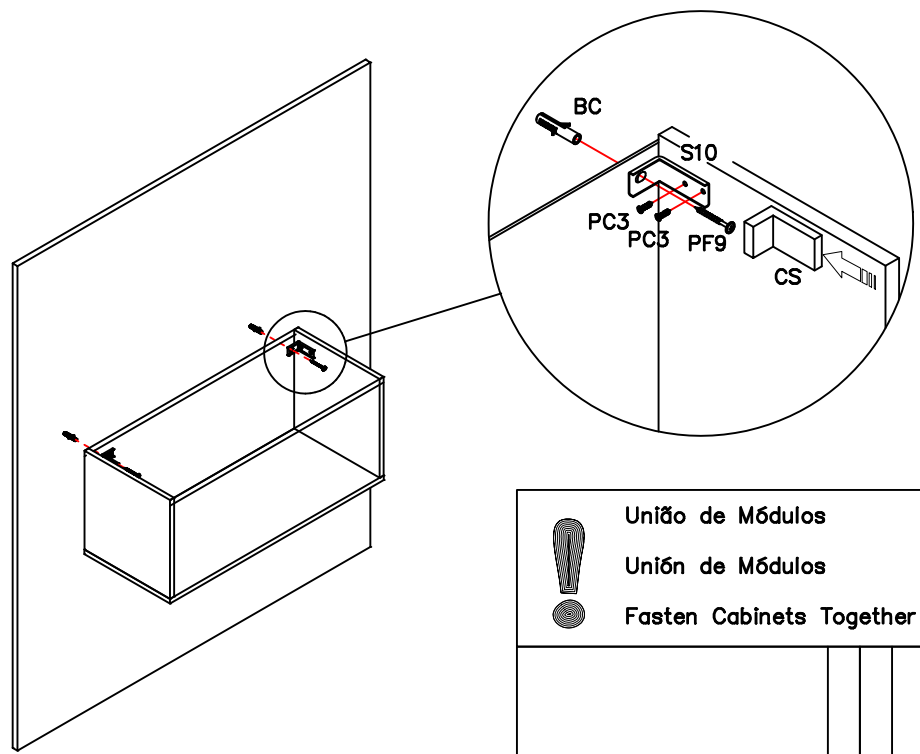

10 PASSO/ PASO/ STEP

PF9			2
PC3			4
PC4			2
S10			2
CS			2
BC			2
TP2			2



 **União de Módulos**
 **Unión de Módulos**
 **Fasten Cabinets Together**

