

Aéreo 01 Porta 400mm Connect | Aéreo 01 Puerta 400mm Connect | Aerial 01 Door 400mm Connect

### Referência/Cor

c C81-35 Duna/Cristal

c C81-42 Fendi

Requisitos para montagem

Requisitos para la montaje

Assembly Requirements

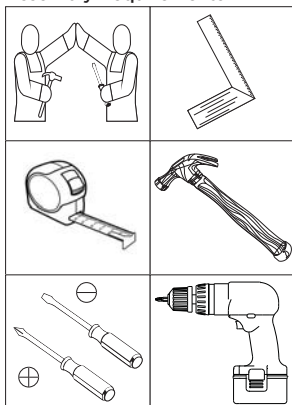

Imagens meramente ilustrativas  
Imágenes meramente ilustrativas  
Images for illustration only

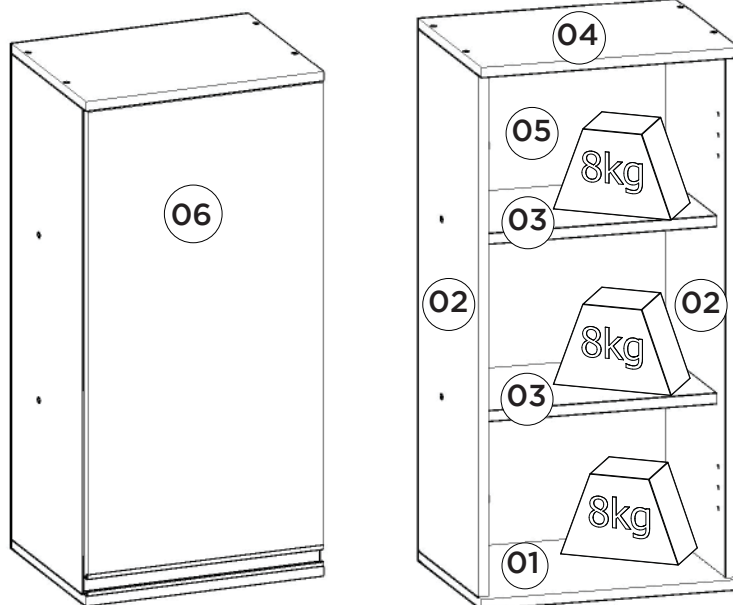









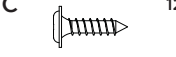
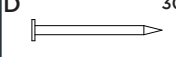

Pesos máximos recomendados com carga distribuída  
Peso máximo recomendado con la carga distribuida  
Recommended maximum weight with distributed load.

### Lista de Peças | Lista de piezas | List of parts

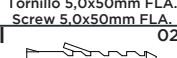
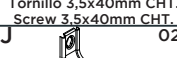
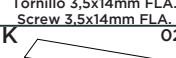
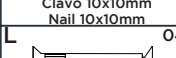
Item	Caixa Caja Box	Qtd Ctd Qty	Descrição   Descripción   Description	Medidas (mm)   Dimensions (mm)   Size (measurements) (mm)
01=04	1/1	01	Base tampo   Base cubierta   Base top	400x310x15
02	1/1	02	Lateral Direita Esquerda   Lateral Derecha Izquierda   Right Side Left	800x295x15
03	1/1	02	Prateleira   Estante   Shelf	369x250x15
04=01	1/1	01	Base tampo   Base cubierta   Base top	400x310x15
05	1/1	01	Fundo   Fondo   Bottom	824x394x3
06	1/1	01	Porta   Puerta   Door	767x396x15

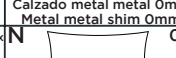
### Ferragens | Herrajes | Hardware

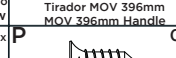
<b>A</b>  02x Parafuso 5,0x50mm FLA. Tornillo 5,0x50mm FLA. Screw 5,0x50mm FLA.	<b>B</b>  12x Parafuso 3,5x40mm CHT. Tornillo 3,5x40mm CHT. Screw 3,5x40mm CHT.	<b>C</b>  12x Parafuso 3,5x14mm FLA. Tornillo 3,5x14mm FLA. Screw 3,5x14mm FLA.	<b>D</b>  30x Prego 10x10mm Clavo 10x10mm Nail 10x10mm	<b>E</b>  16x Cavilha 8x25mm Cinta 8x25mm Dowel 8x25mm	<b>F</b>  02x Calço metal metal 0mm Calzado metal metal 0mm Metal metal shim 0mm	<b>G</b>  02x Dobradiça metal 35mm Colo Baixo Bisagra de metal 35mm Colo Bajo Metal hinge 35mm Colo Low	<b>H</b>  01x Puxador MOV 396mm Tirador MOV 396mm MOV 396mm Handle
<b>I</b>  02x Buchá plástica 8mm Buchá de plástico 8mm 8mm plastic bushing	<b>J</b>  02x Suporte de fixação Soporte de fijación Mounting bracket	<b>K</b>  02x Proteção para cantoneira Ángulo de protección Protection angle	<b>L</b>  04x Parafuso União 30mm Tornillo Unión 30mm Union Screw 30mm	<b>M</b>  02x Batente PVC para Porta Parada de PVC para Puerta PVC Door Stop	<b>N</b>  01x Sachê de cola Bolsa de pegamento Glue bag	<b>O</b>  12x Adesivo tapa parafuso 10mm Adhesivo tapón de tornillo 10mm Bolt cover adhesive 10mm	<b>P</b>  02x Parafuso 3,5x12mm CHT. Tornillo 3,5x12mm CHT. Screw 3,5x12mm CHT.



O parafuso (L) deve ser usada somente quando este módulo for acoplado a outro módulo componível Henn.



El tornillo (L) se debe utilizar sólo cuando el módulo está conectado a otro módulo componible Henn.



The screw (L) should be used only when this module is attached to another Henn modular module.

### RECOMENDAÇÃO

Para fixar o móvel na parede usar o suporte de fixação (J), o parafuso 3,5x14mm FLA (C), a Bucha 8mm (I) e o parafuso 5,0x50mm FLA (A).

### RECOMENDACIÓN

Para conectar el móvil a la pared con el soporte (J), tornillo 3,5 x14mm FLA (C), el casquillo de 8 mm (I) y el 5,0 x50mm tornillo FLA (A).

### RECOMMENDATION

To fix the furniture to the wall use the fixing bracket (J), the 3.5x14mm FLA (C) screw, the 8mm bushing (I) and the 5.0x50mm FLA screw (A).

1º

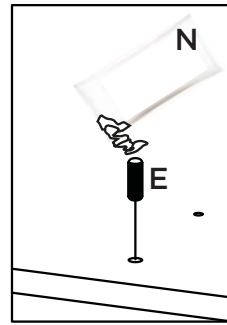
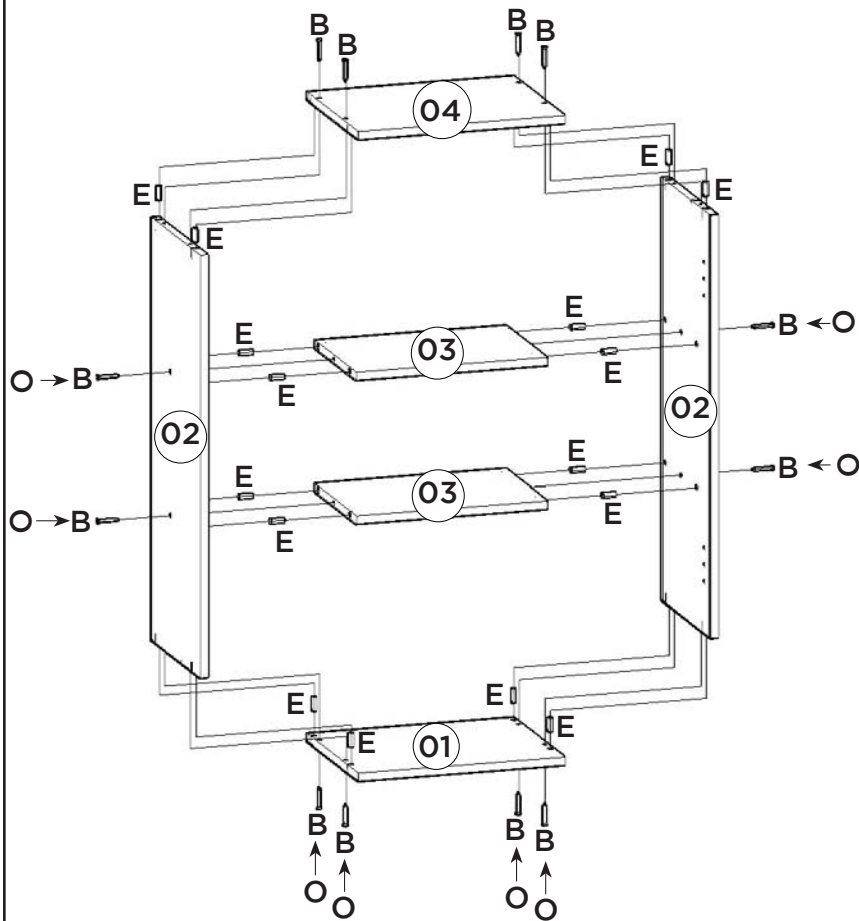

Utilizar o sachê de cola (N) em todas as cavilhas (E) do produto.

Con el pegamento sobre (N) en todos los pernos (E) producto.

Use the glue sachet (N) on all the pegs (E) of the product.

**AVISO**

Para limpeza de seu móvel, use uma flanela seca ou umedecida, e não utilize produtos químicos que possam danificar seu produto.

**SISTEMA DE MONTAGEM**

O sistema de montagem dos produtos, funciona de acordo com a ordem crescente dos números indicados no desenho. Ex: 01, 02, 03, 04... até a conclusão da montagem.

**ADVERTENCIA**

Para limpieza de su móvil, use una flanela seca o húmeda, y no utilice productos químicos que puedan dañar su producto.

**SISTEMA DE MONTAJE**

El sistema de montaje de los productos funciona de acuerdo con el orden creciente de los números indicados en el dibujo. Ej.: 01, 02, 03, 04... hasta la conclusión del montaje.

2º

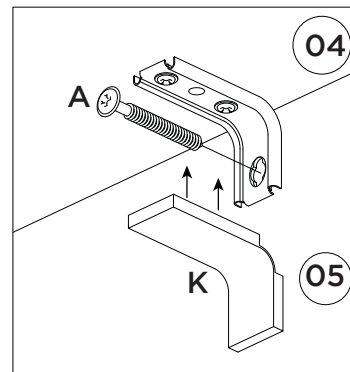
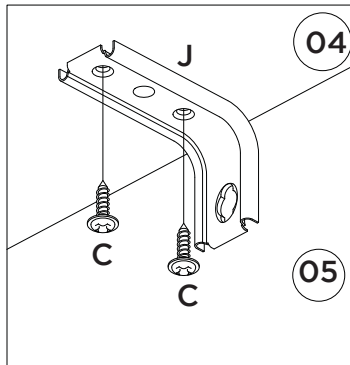
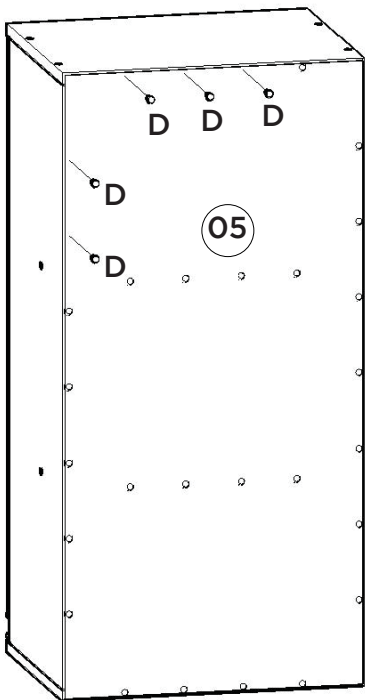

**NOTICE**

To clean your furniture, use a dry or wet cloth, and do not use chemicals that may damage your product.

**ASSEMBLY SYSTEM**

The products' assembly system works according to the increasing order of the indicated numbers. For example: 01, 02, 03, 04 ... to the end of the assembly.

3º

