

**Aéreo Canto**  
**Armário Esquinero**  
**Cozinha/Cocina**  
**Verace**

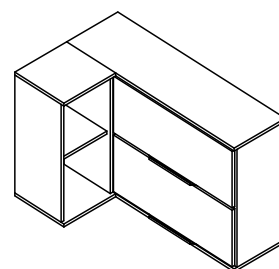

*Direito/Derecho*

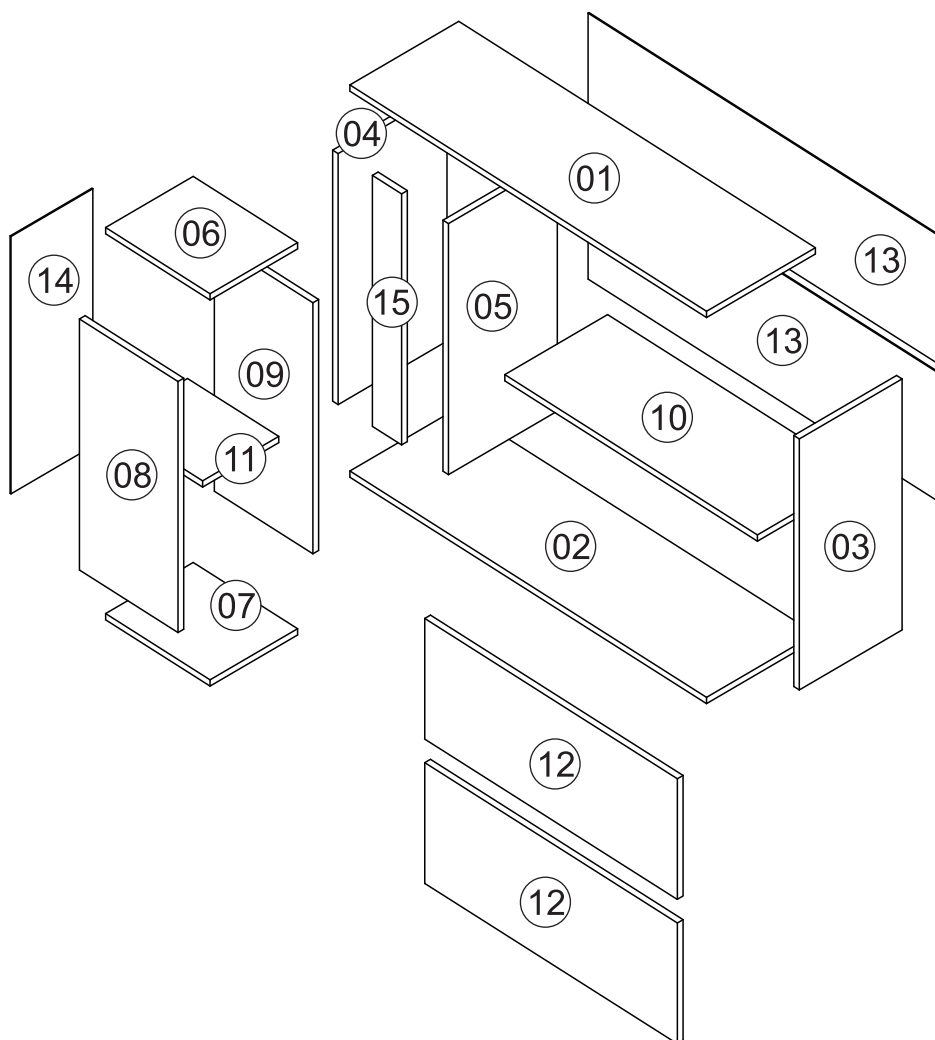
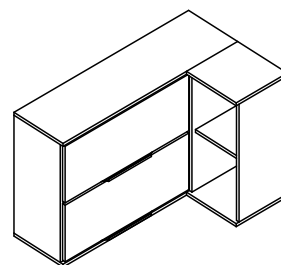

*Esquerdo/Izquierdo*

Nº	CÓDIGO ASSISTÊNCIA	NOME DA PEÇA/DESCRIPCIÓN PIEZAS	MEDIDAS (mm)	QTD.	CÓDIGO DAS PEÇAS/CÓDIGO PIEZAS			
					HAVANA	TAUPE	TAUPE	OFF WHITE
01	AVE06.05.00	Base superior/Base superior	977x286x15	01	127755		127747	
02	AVE06.01.00	Base inferior/Base inferior	977x286x15	01	48101		53309	
03	AVE06.18.00	Lateral menor/Lateral pequena	600x270x15	01	48102		53310	
04	AVE06.17.00	Lateral maior/Lateral mayor	600x286x15	01	48103		53311	
05	AVE06.19.00	Lateral interna/Divisoria	600x286x15	01	48104		53312	
06	AVE06.05.01	Base superior/Base superior	290x286x15	01	48105		53313	
07	AVE06.01.01	Base inferior/Base inferior	290x286x15	01	48106		53314	
08	AVE06.18.01	Lateral adega esquerda/Lateral izquierda	600x270x15	01	48107		53315	
09	AVE06.17.01	Lateral adega direita/Lateral derecha	600x270x15	01	48108		53316	
10	AVE06.27.00	Prateleira interna/Repisa	684x270x15	01	64695		64674	
11	AVE06.27.01	Prateleira adega/Repisa	260x255x15	01	48110		53318	
12	AVE06.25.00	Porta/Puerta	692x290x15	02		64696		64675
13	AVE06.13.00	Forro maior/Revés mayor	710x313x2.5	02	47451		47451	
14	AVE06.13.01	Forro adega/Revés	620x284x2.5	01	65687		65787	
15	AVE06.06.00	Ripa batente/Travesaño	600x80x15	01	46010		46010	

# Ferragens/Herrajes

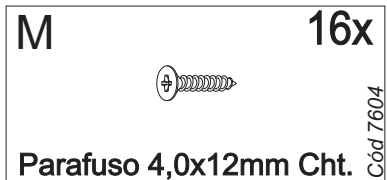
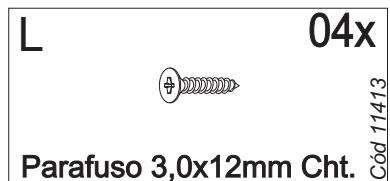
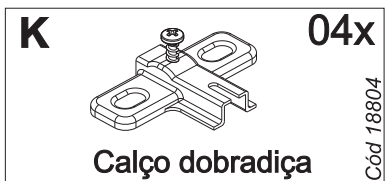
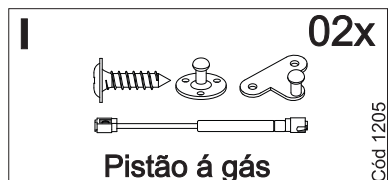
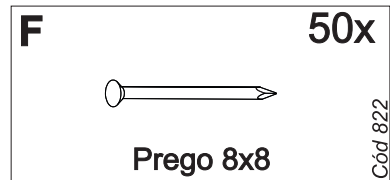
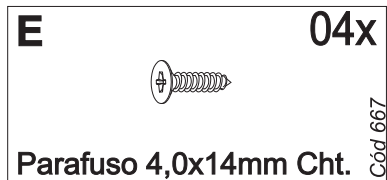
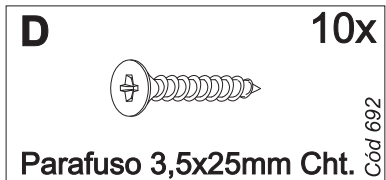
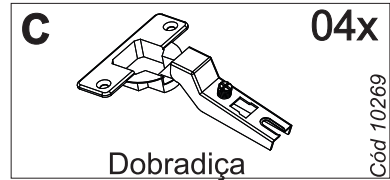
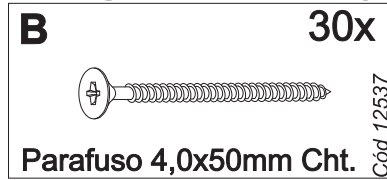
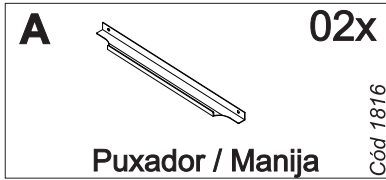

\*Usar os parafusos (D) para unir este módulo a outro.  
Usar los tornillos (D) para unirse este módulo a otro.

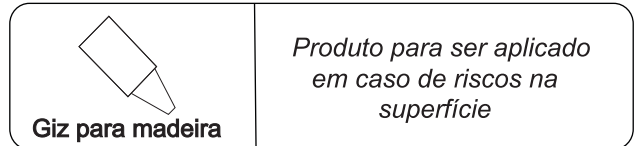
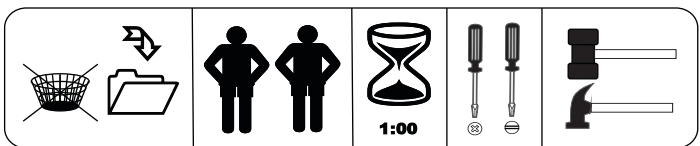

Produto para ser aplicado em caso de riscos na superfície

## Pré-Montagem/Preparación Piezas

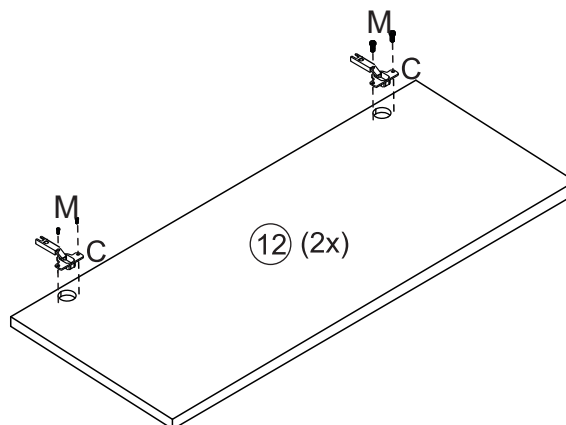

# Montagem/Montaje

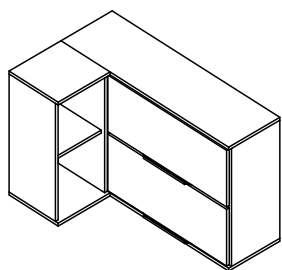

Direito/Derecho

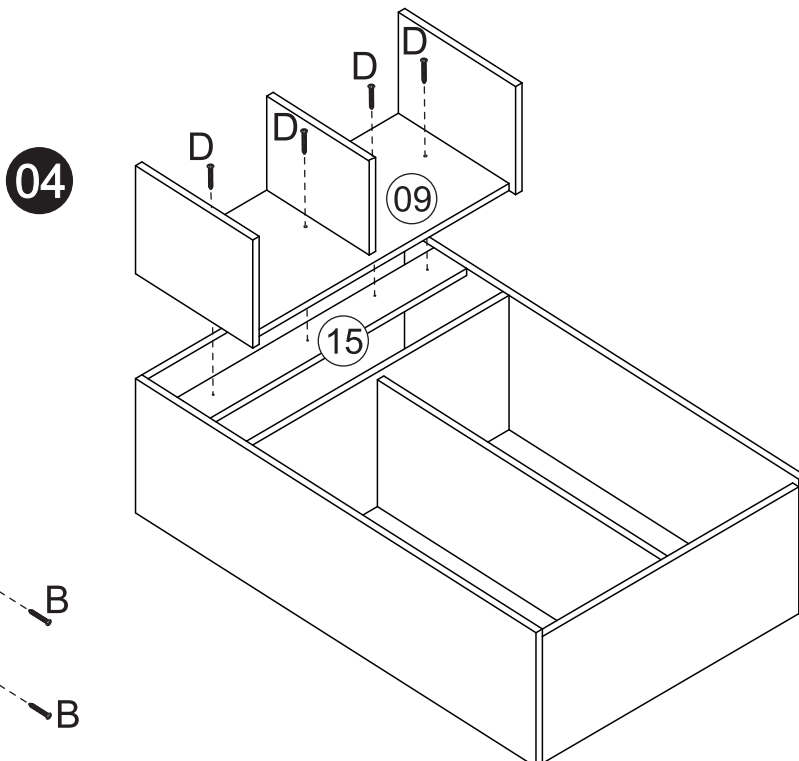
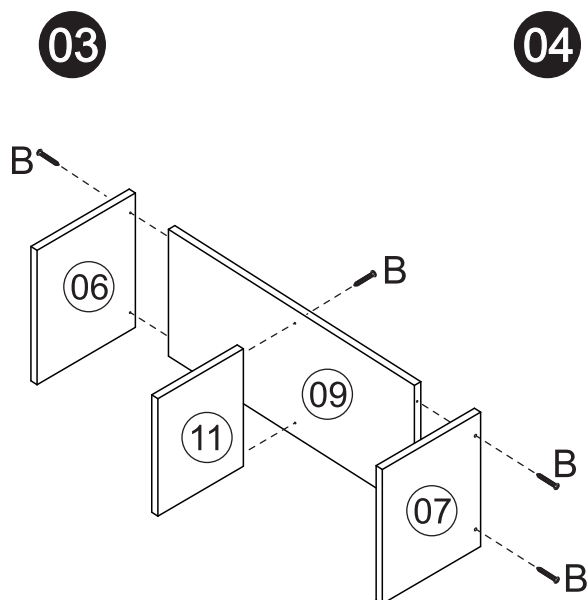
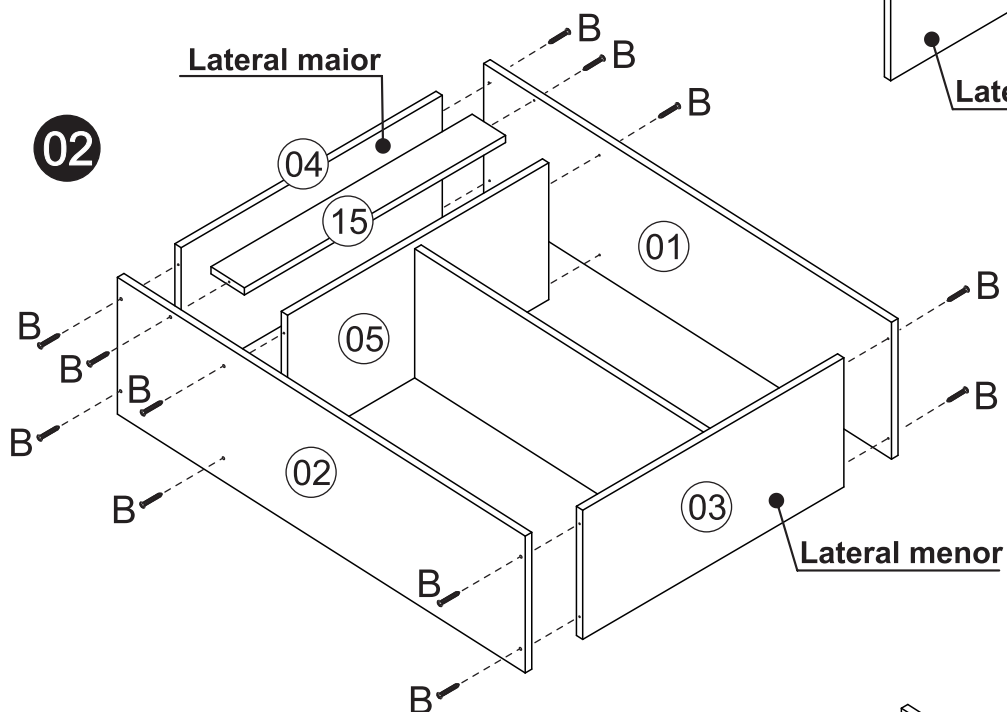
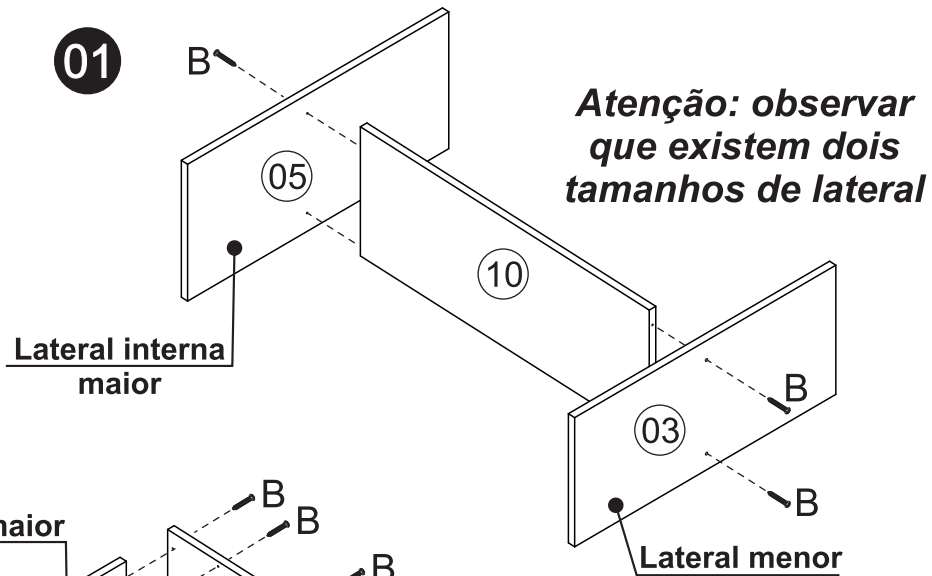

# Montagem/Montaje

05

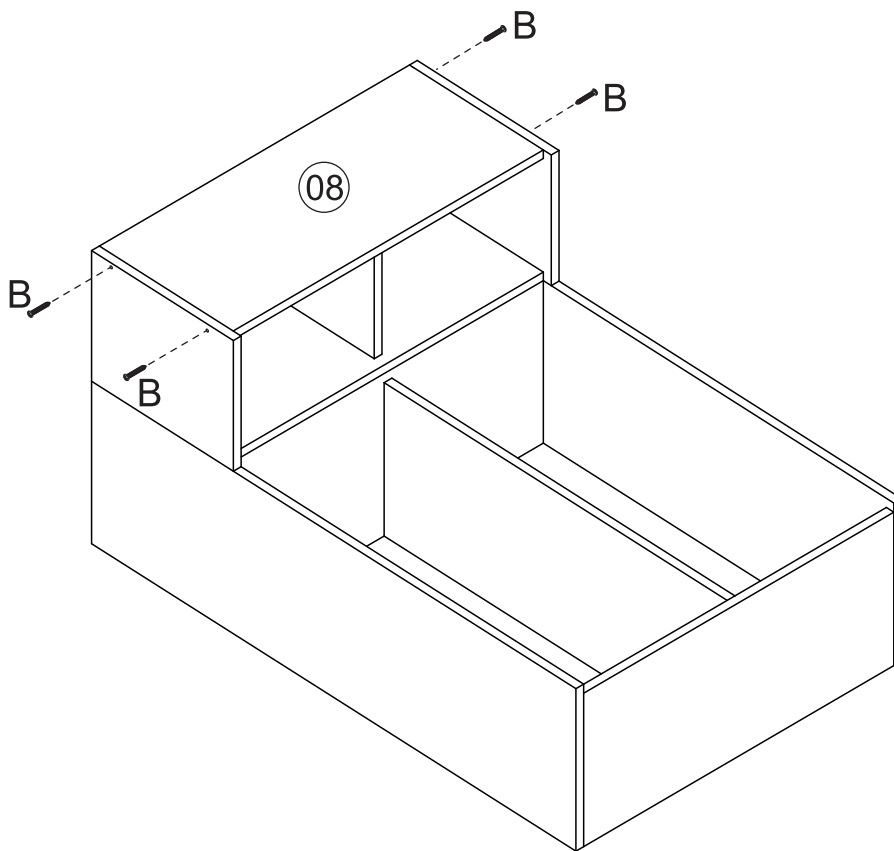

06

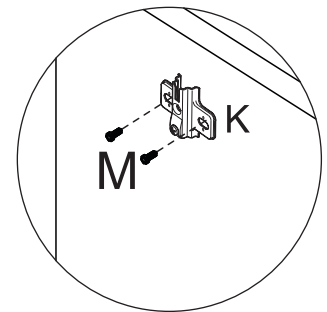
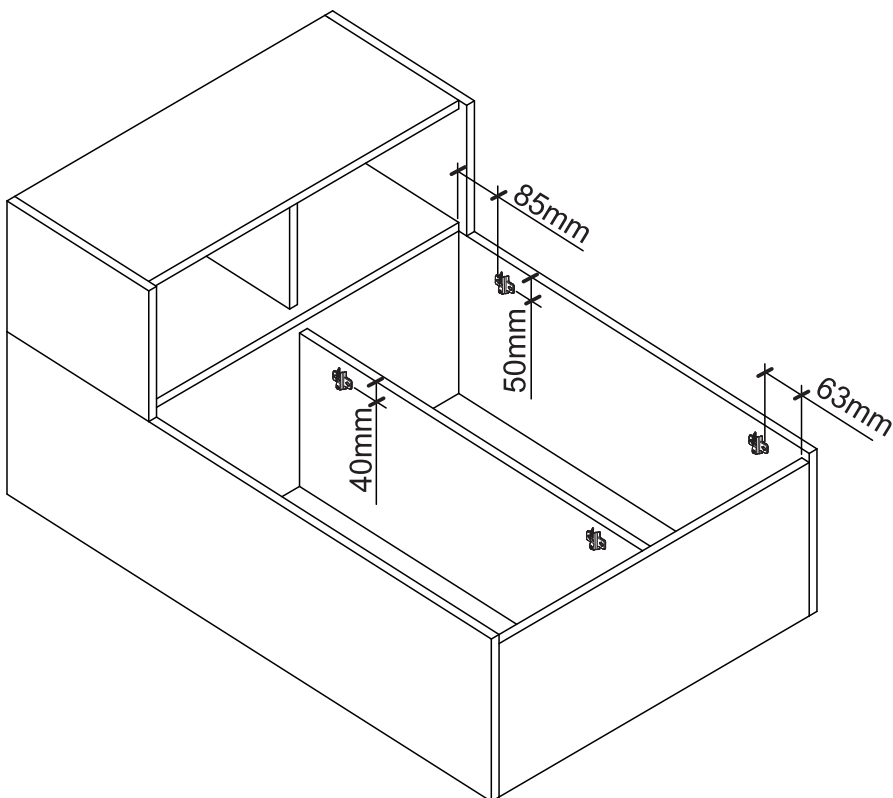

**Atenção: observar medidas indicadas para fixação do calço**

# Montagem/Montaje

07

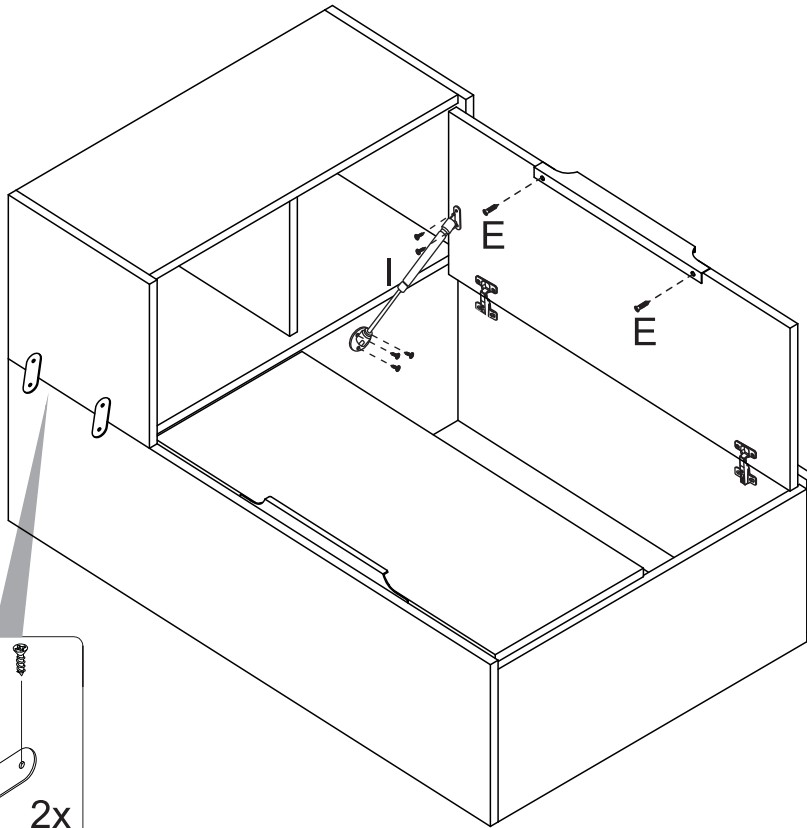

08

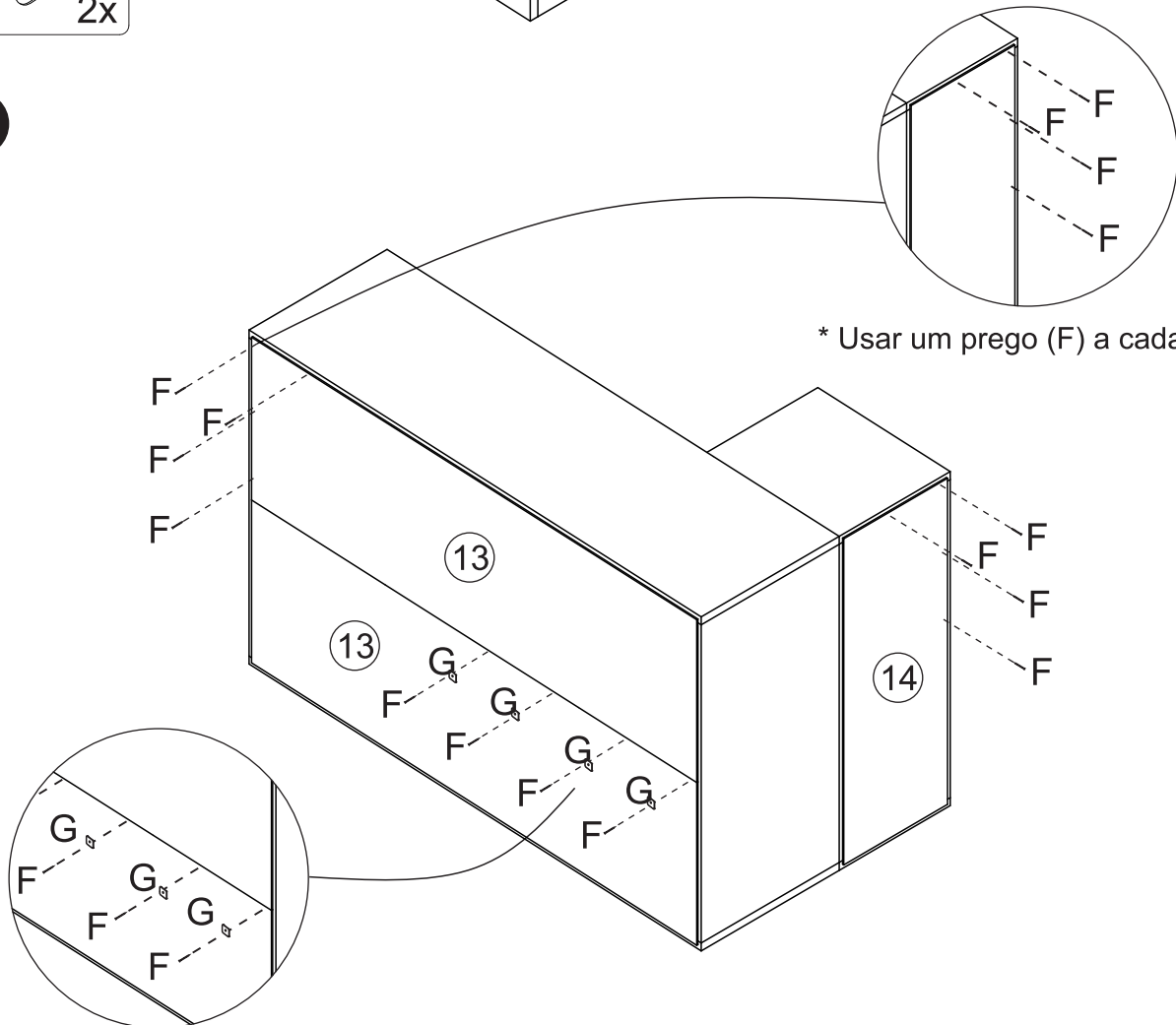

\* Usar um prego (F) e um junção (G) a cada 100mm

# Montagem/Montaje

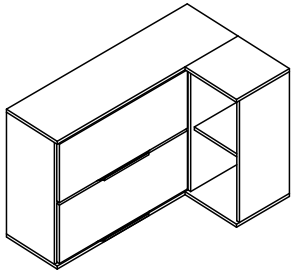

Esquerdo/Izquierdo

01

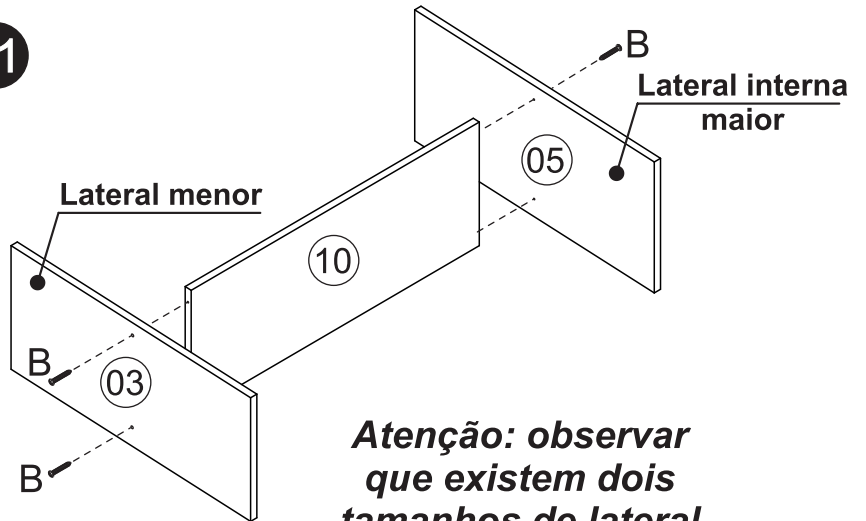

**Atenção: observar que existem dois tamanhos de lateral**

02

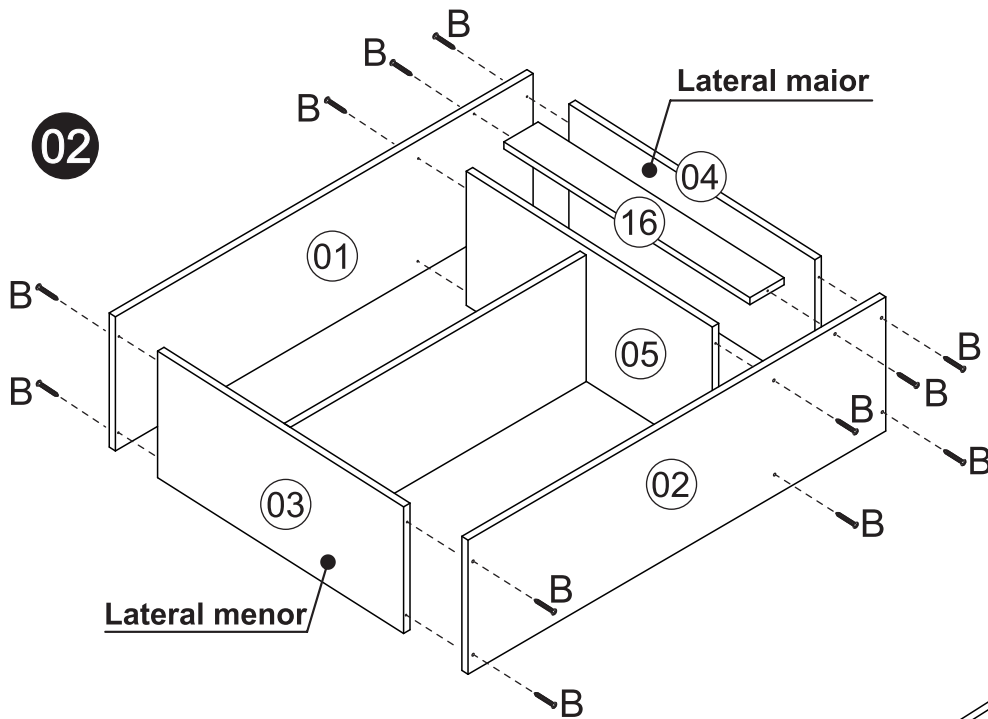

03

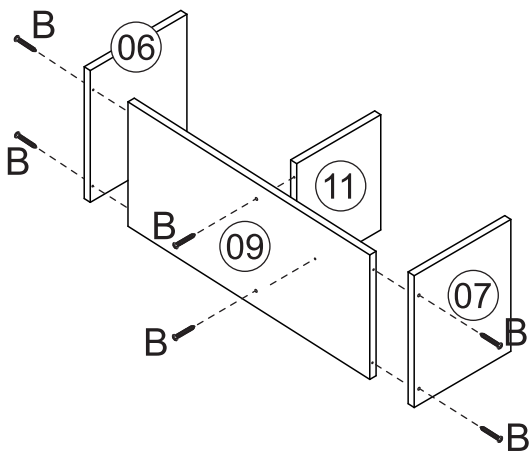

04

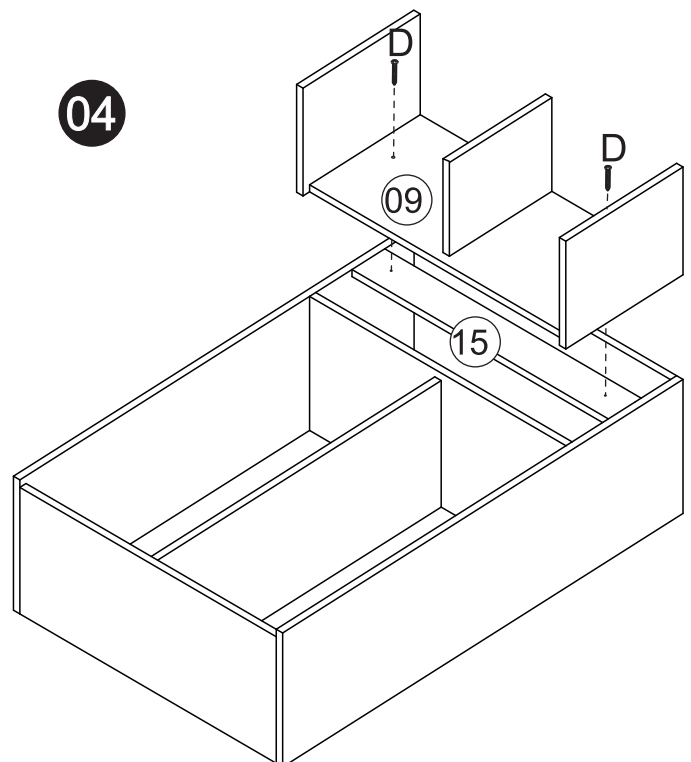

# Montagem/Montaje

05

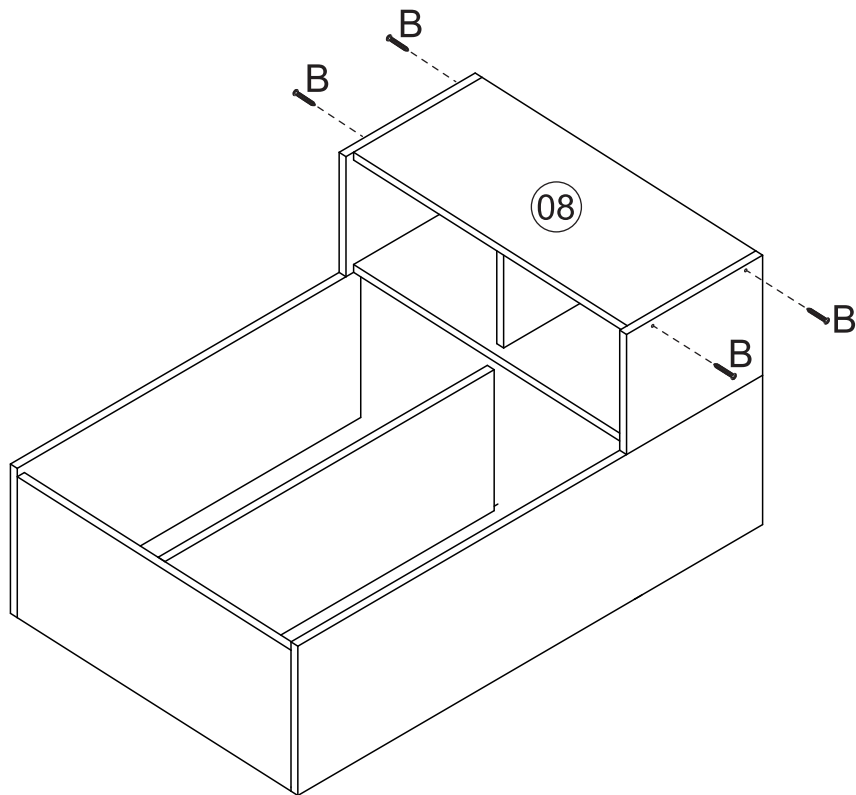

06

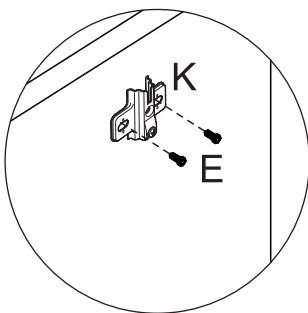

**Atenção: observar medidas indicadas para fixação do calço**

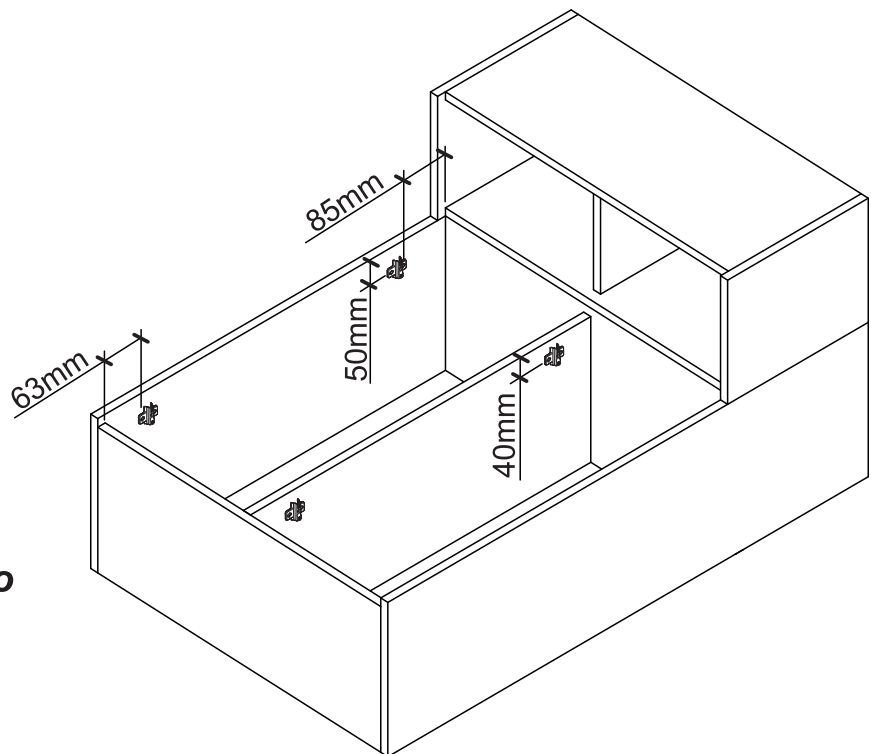

# Montagem/Montaje

07

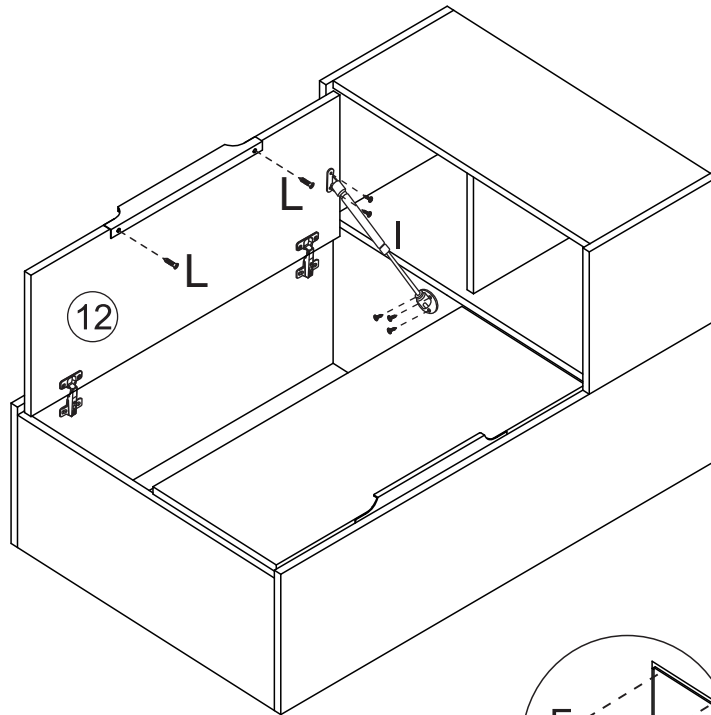
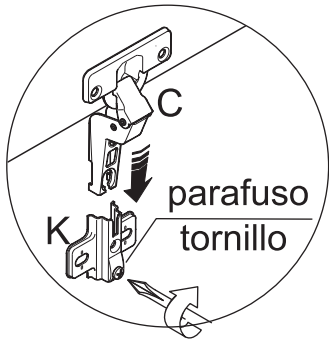

08

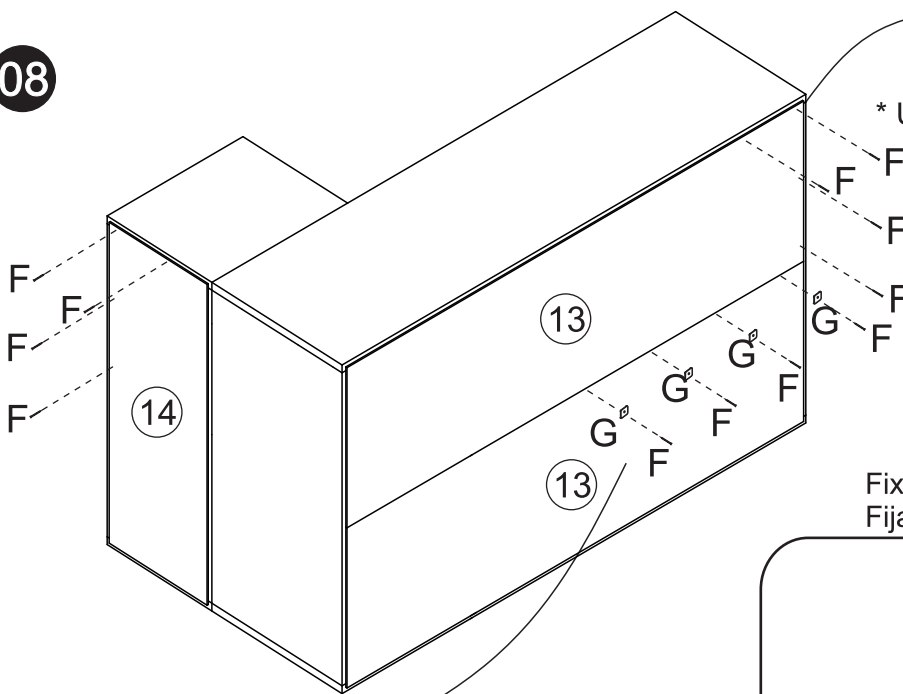

\* Usar um prego (F) a cada 12mm

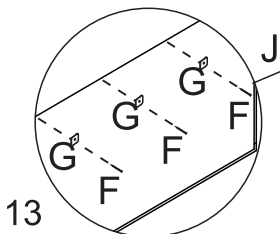

\* Usar um prego (F) e uma junção (G) a cada 12mm

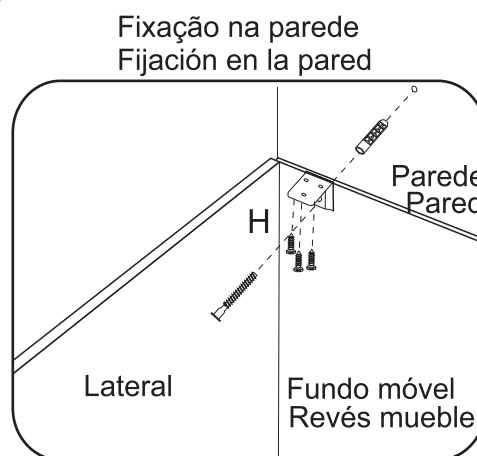

\* Fixar a cantoneira na parte interna do móvel.  
Fijar la pieza «H» en el interior del mueble.

\* Usar os outros 4 parafusos (D) para unir este módulo a outro.  
Usar los otros tornillos (D) para unirse este modulo a otro.

## Limpeza/Limpieza

- ✗ Use um pano levemente umedecido com água, seguido de pano seco.
- ✗ Use solamente un paño húmedo con agua y después un paño seco.
- ✗ Nunca utilize produtos químicos ou abrasivos.
- ✗ No utilice productos químicos o abrasivos.