

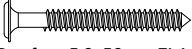









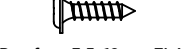
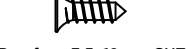

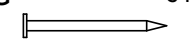
Item	Caixa Caja Box	Qtd Ctd Qty	Descrição Descripción Description	Medidas (mm) Dimensions (mm) Size (measurements) (mm)
01	1/1	01	Base Base Base	1200x265x15
02	1/1	01	Lateral esquerda Lateral izquierda Left side	632x265x12
03	1/1	01	Lateral direita Lateral derecha Right side	632x265x12
04	1/1	01	Divisória Menor Partición Menor Minor Partition	263x182x15
05	1/1	01	Prateleira Inferior Estante Inferior Lower Shelf	1175x265x12
06	1/1	01	Divisão División Division	216x218x12
07	1/1	01	Prateleira Estante Shelf	1175x220x12
08	1/1	01	Tampo Tapa Top	1200x265x12
09	1/1	02	Fundo Fondo Bottom	1193x227x3
10	1/1	01	Fundo Inferior Fondo Abajo Under Bottom	1193x203x3
11	1/1	01	Porta de Vidro Reflecta Puerta de cristal reflectante Reflecta Glass Door	1195x458x20

Ferragens | Herrajes | Hardware

A 03x  Parafuso 5,0x50mm FLA. Tornillo 5,0x50mm FLA. Screw 5,0x50mm FLA.	B 21x  Parafuso 3,5x40mm CHT. Tornillo 3,5x40mm CHT. Screw 3,5x40mm CHT.	C 12x  Parafuso 3,5x12mm FLA. Tornillo 3,5x12mm FLA. Screw 3,5x12mm FLA.	D 02x  Parafuso 3,5x12mm CHT. Tornillo 3,5x12mm CHT. Screw 3,5x12mm CHT.	E 06x  Parafuso União 11,5mm Tornillo Unión 11,5mm Union Screw 11,5mm
F 21x  Cavilha 5x25mm Cinta 5x25mm Dowel 5x25mm	G 54x  Prego 10x10mm Clavo 10x10mm Nail 10x10mm	H 01x  Perfil Puxador 2015 - 150mm Perfil de Tirador 2015 - 150mm Profile Handle 2015 - 150mm	I 20x  Fixador de fundos Fijador de fondos Bottom fixer	J 02x  Kit Pistão a Gás 60N Kit Pistón a Gas 60N 60N Gas Piston Kit
K 03x  Dobradiça metal 35mm Alta Bisagras metálicas 35mm Alta Metal hinge 35mm High	L 03x  Calço metal Médio 0mm Cuña Metalica Mediana 0mm Medium Metal shim 0mm	M 03x  Batente PVC para Porta Parada de PVC para Puerta PVC Door Stop	N 03x  Bucha plástica 8mm Bucha de plástico 8mm 8mm plastic bushing	O 03x  Suporte de fixação Soporte de fijación Mounting bracket
P 03x  Proteção para cantoneira Ángulo de protección Protection angle	Q 01x  Sachê de cola Bolsa de pegamento Glue bag	R 21x  Adesivo tapa parafuso 10mm Adhesivo tapón de tornillo 10mm Bolt cover adhesive 10mm	S 06x  Parafuso 3,5x22mm CHT Tornillo 3,5x22mm CHT Screw 3,5x22mm CHT	

O parafuso (S) deve ser usada somente quando este módulo for acoplado a outro módulo componível Briz.

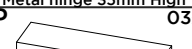
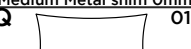
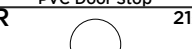
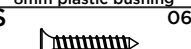
El tornillo (S) se debe utilizar sólo cuando el módulo está conectado a otro módulo componible Briz.

The screw (S) should be used only when this module is attached to another Briz modular module.

RECOMENDAÇÃO

Para fixar o móvel na parede usar o suporte de fixação (O), o parafuso 3,5x12mm FLA (C), a Bucha 8mm (N) e o parafuso 5,0x50mm FLA (A).

RECOMENDACIÓN

Para conectar el móvil a la pared con el soporte (O), tornillo 3,5 x12mm FLA (C), el casquillo de 8 mm (N) y el 5,0 x50mm tornillo FLA (A).

RECOMMENDATION

To fix the furniture to the wall use the fixing bracket (O), the 3.5x12mm FLA (C) screw, the 8mm bushing (N) and the 5.0x50mm FLA screw (A).



Ind. e Com. de Móveis Henn
Mondai - SC - Brasil

+55 49 3674.3500

@f @moveishenn
www.henn.com.br

INSTRUÇÕES DE MONTAGEM

INSTRUCCIONES DE MONTAJE
ASSEMBLY INSTRUCTIONS

Aéreo 01 Porta de Vidro Basculante
Air 01 Puerta basculante de cristal
Air 01 Tilting glass door

c B230-166 Nature/Cinza

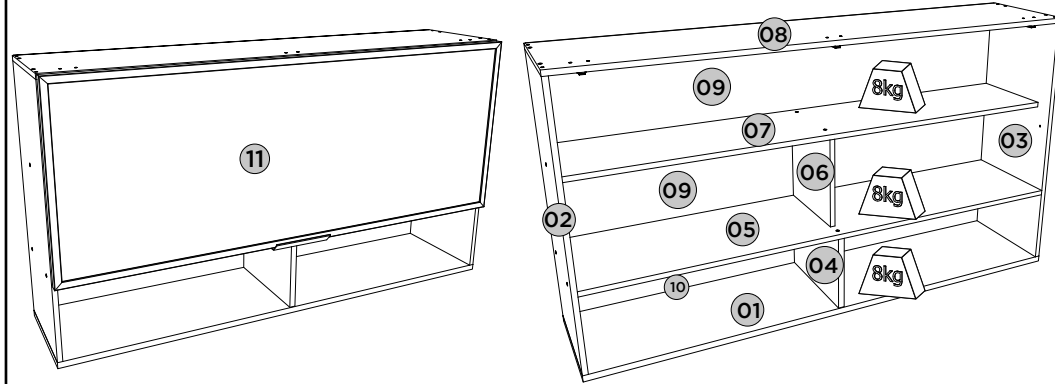

Pesos máximos recomendados com carga distribuída
Peso máximo recomendado con la carga distribuida
Recommended maximum weight with distributed load.

Requisitos para montagem
Requisitos para la montaje
Assembly Requirements

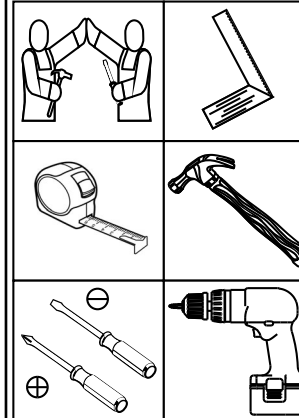

Imagens meramente ilustrativas,
não acompanha o produto.
Imágenes ilustrativas, no incluidas
con el producto.
Illustrative images, not included
with the product.

AVISO

Para limpeza de seu móvel, use uma flanela seca ou umedecida, e não utilize produtos químicos que possam danificar seu produto.

SISTEMA DE MONTAGEM

O sistema de montagem dos produtos, funciona de acordo com a ordem crescente dos números indicados no desenho. Ex: 01, 02, 03, 04... até a conclusão da montagem.

ASISTENCIA TÉCNICA

Para solicitação de Assistência Técnica você consumidor deverá entrar em contato com o Lojista a qual você realizou a compra deste produto e solicitar a assistência técnica das peças avariadas. A garantia abrange todas as peças, partes e componentes que eventualmente venham apresentar defeito de fabricação no prazo de 03 (três) meses, contando a partir da entrega do produto ao consumidor, mediante nota fiscal de compra. Se houver qualquer alteração na estrutura do produto ou ocorrer defeito por negligência do montador/consumidor em relação a instrução de montagem e manuseio, não será fornecido assistência técnica gratuita.

ADVERTENCIA

Para limpieza de su móvil, use una flanela seca o húmeda, y no utilice productos químicos que puedan dañar su producto.

SISTEMA DE MONTAJE

El sistema de montaje de los productos funciona de acuerdo con el orden creciente de los números indicados en el dibujo. Ej.: 01, 02, 03, 04... hasta la conclusión del montaje.

ASISTENCIA TÉCNICA

Para solicitar Asistencia Técnica, el consumidor debe comunicarse con el Comercio que usted realizó la compra de este producto y solicita asistencia técnica para las partes dañadas. La garantía cubre todas las partes, piezas y componentes que eventualmente puedan presentar defecto de fabricación en el plazo de 03 (tres) meses, contados a partir de la entrega del producto al consumidor, mediante factura de compra. Si se produce algún cambio en la estructura del producto o se produce un defecto por negligencia del montador/consumidor en relación con las instrucciones de montaje y manipulación, no se prestará asistencia técnica gratuita.

NOTICE

To clean your furniture, use a dry or wet cloth, and do not use chemicals that may damage your product.

ASSEMBLY SYSTEM

The products' assembly system works according to the increasing order of the indicated numbers. For example: 01, 02, 03, 04 ... to the end of the assembly.

TECHNICAL ASSISTANCE

To request Technical Assistance, the consumer must contact the retailer from whom you purchased this product and request technical assistance for the damaged parts. The warranty covers all parts, parts and components that may eventually present a manufacturing defect within a period of 03 (three) months, counting from the delivery of the product to the consumer, by means of a purchase invoice. If there is any change in the structure of the product or defect occurs due to negligence of the assembler/consumer in relation to the assembly and handling instruction, free technical assistance will not be provided.

1º

ITM/B230-

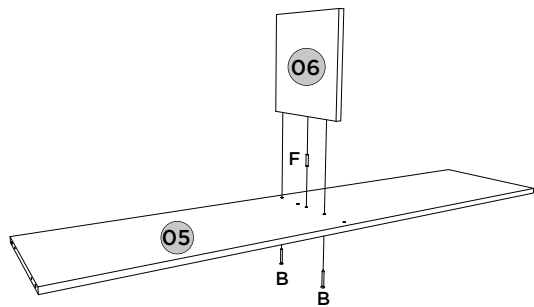

2º

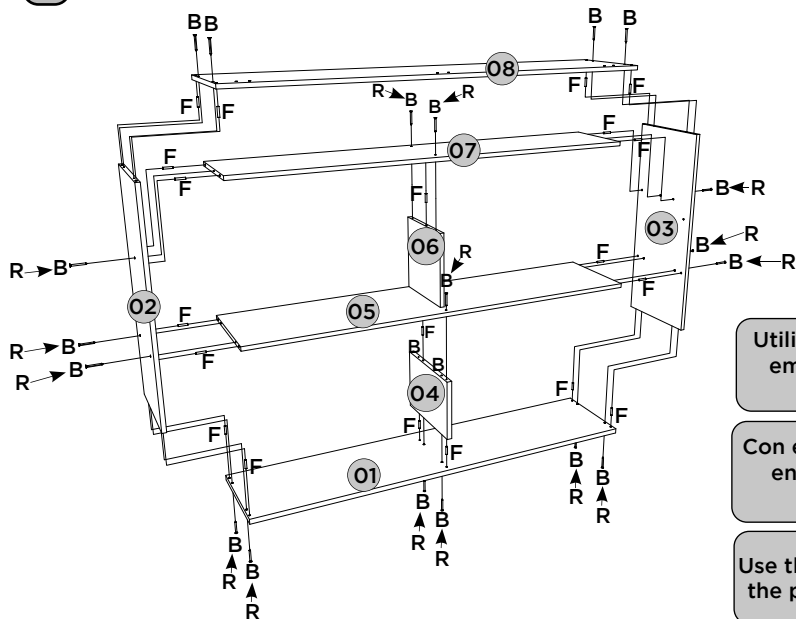

Utilizar o sachê de cola (Q) em todas as cavilhas (F) do produto.

Con el pegamento sobre (Q) en todos los pernos (F) producto.

Use the glue sachet (Q) on all the pegs (F) of the product.

3º

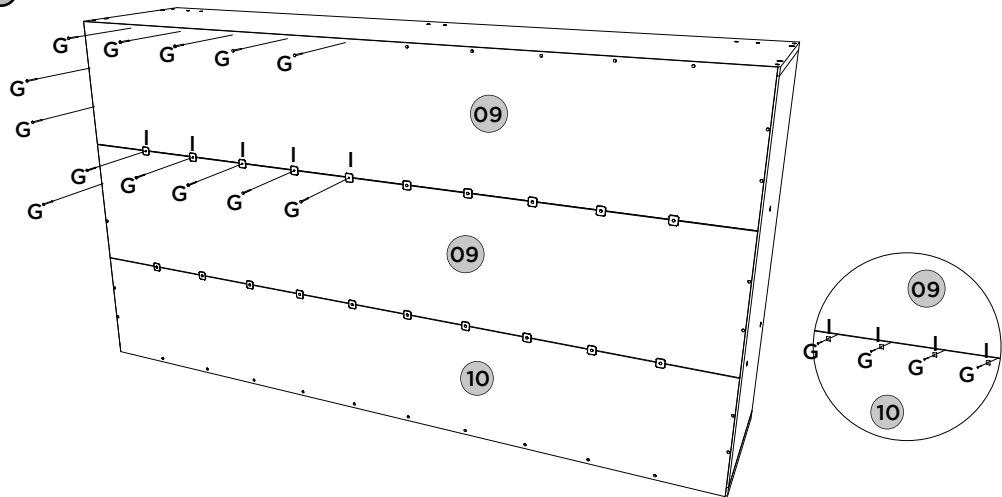

4º

Regulagem do pistão sempre o mais distante possível da dobradiça.

Ajuste de pistón siempre en la medida de lo posible, la bisagra.

Adjust the piston as far as possible from the hinge.

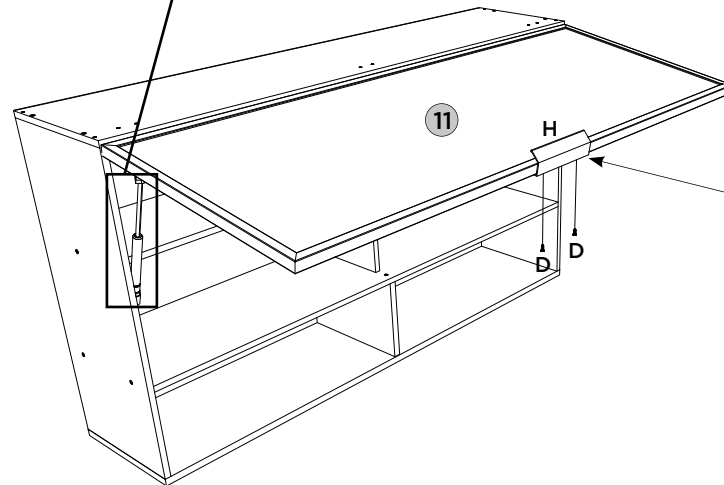

- Puxador Centralizado na porta
- Tirador centralizado en la puerta
- Centralized handle on the door

Regulagem do parafuso da dobradiça no máximo para dentro, afastando a porta doampo, isso apenas nas duas extremidades da porta. Já na dobradiça central da porta o parafuso deverá ficar na regulagem normal (no meio).

Ajuste del tornillo de la bisagra en el máximo hacia dentro, alejando la puerta de la tapa, sólo en los dos extremos de la puerta. En la bisagra central de la puerta, el tornillo deberá quedar en la regulación normal (en el centro).

Adjusting the hinge bolt to maximum inside, pushing the door off the top, this only at both ends of the door. In the central hinge of the door the bolt should be in the normal setting (in the middle).



- Video: Instalar e regular Dobradiças
- Video: Instale y ajuste las bisagras
- Video: Install and adjust hinges

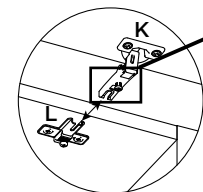
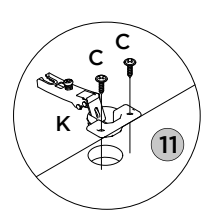
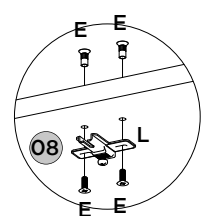

- Video: Dicas para instalar o Kit Pistão à Gás
- Video: Consejos para instalar el kit de pistón de gas
- Video: Tips for installing the Gas Piston Kit

