

# Manual de montagem

Instrucciones de montaje Assembly instructions

## AER105AMDP

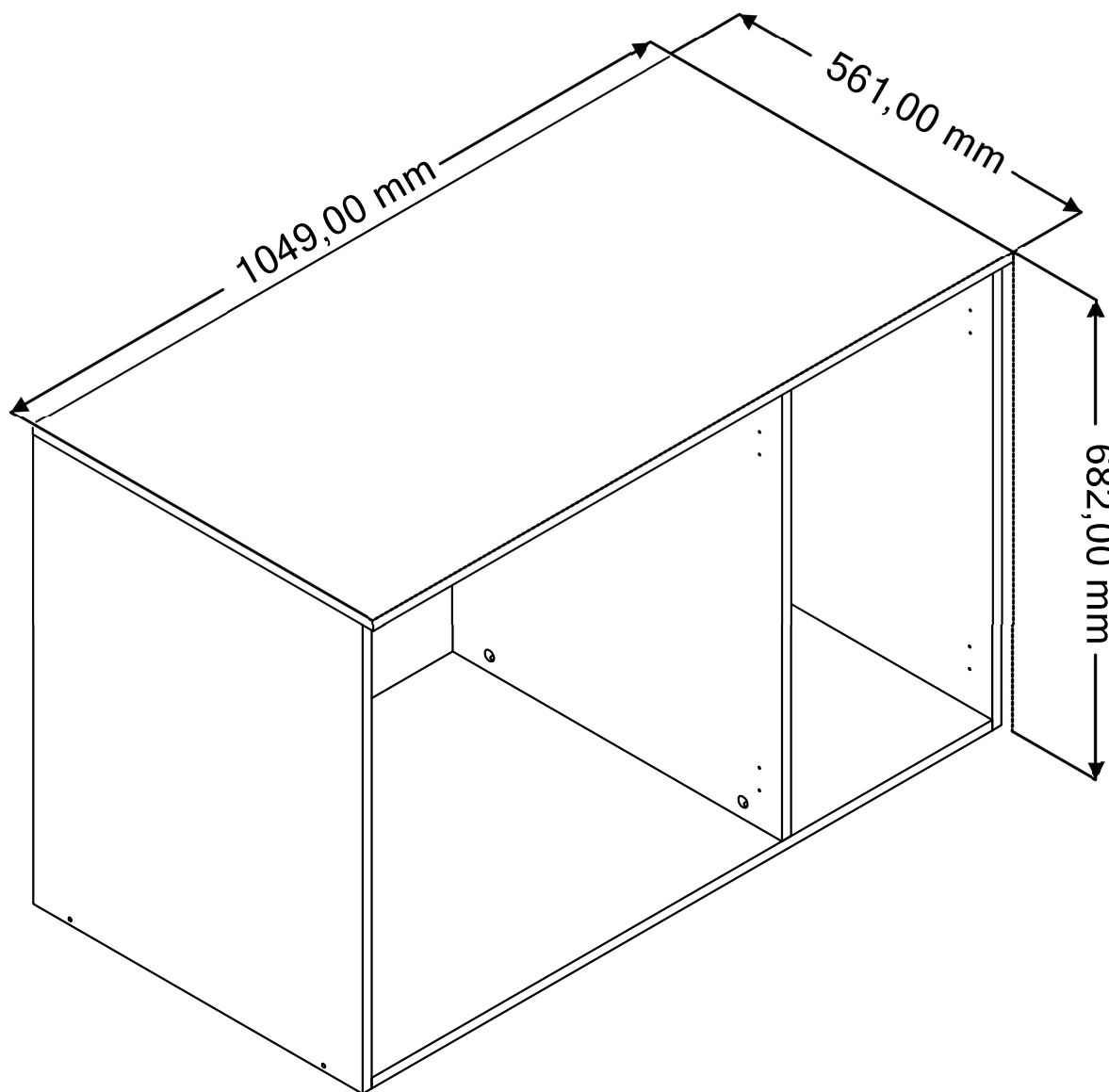

**! Imagens meramente ilustrativas !**  
Imágenes ilustrativas/Images merely illustrative.

Dúvidas? Entre em contato:  
Dudas? Ponerse em contacto:  
Doubts? Get in touch:  
(51) 3635-8839

A montagem deve ser efetuada por 2 pessoas.

El montaje debe ser efectuada por 2 personas.

The assembly must be done by 2 people.

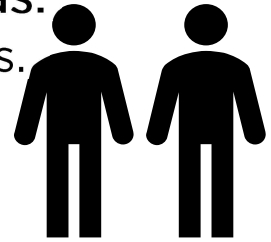

Ferramentas necessárias para montar o móvel.

Herramientas necesarias para armar el mueble.

Tools needed to assemble the furniture.



Dúvidas? Entrar em contato:

Dudas? Ponerse en  
contacto:

Doubts? Get in touch:

Fone: (51) 3635-8839

[www.kappesberg.com.br](http://www.kappesberg.com.br)



Montar o móvel sobre uma superfície limpa e plana.

Armar el mueble sobre una superficie limpia y plana.

Assemble the furniture on a clean, flat surface.

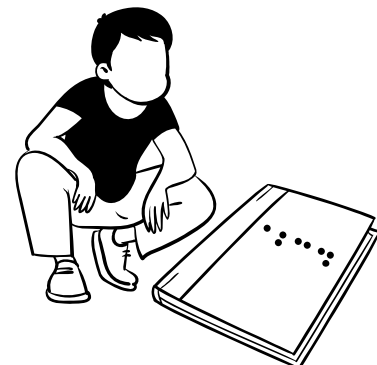

**IDENTIFICAÇÃO DAS PEÇAS / IDENTIFICACIÓN DE LAS PIEZAS  
PARTS IDENTIFICATION**

Quantidade / Cantidad / Amount	Código / Code	Descrição	Descripción	Description	C x L x E	L x W x T
1	P102304	LATERAL DIREITA	LADO DIRECTO	RIGHT SIDE	667 x 540 x 15 mm	26.26 x 21.26 x 0.59 in
1	P102305	BASE	BASE	BASE	1018 x 540 x 15 mm	40.08 x 21.26 x 0.59 in
1	P102355	LATERAL ESQUERDA	LADO EZQUIERDO	LEFT SIDE	667 x 540 x 15 mm	26.26 x 21.26 x 0.59 in
1	P102308	CHAPÉU	SOMBRERO	HAT	1049 x 558 x 15 mm	41.30 x 21.97 x 0.59 in
1	P102309	DIVISORIA	DIVISION	DIVISION	652 x 540 x 15 mm	25.67 x 21.26 x 0.59 in
2	P102310	COSTA	COSTA	COAST	1038 x 334 x 3 mm	40.87 x 13.15 x 0.12 in

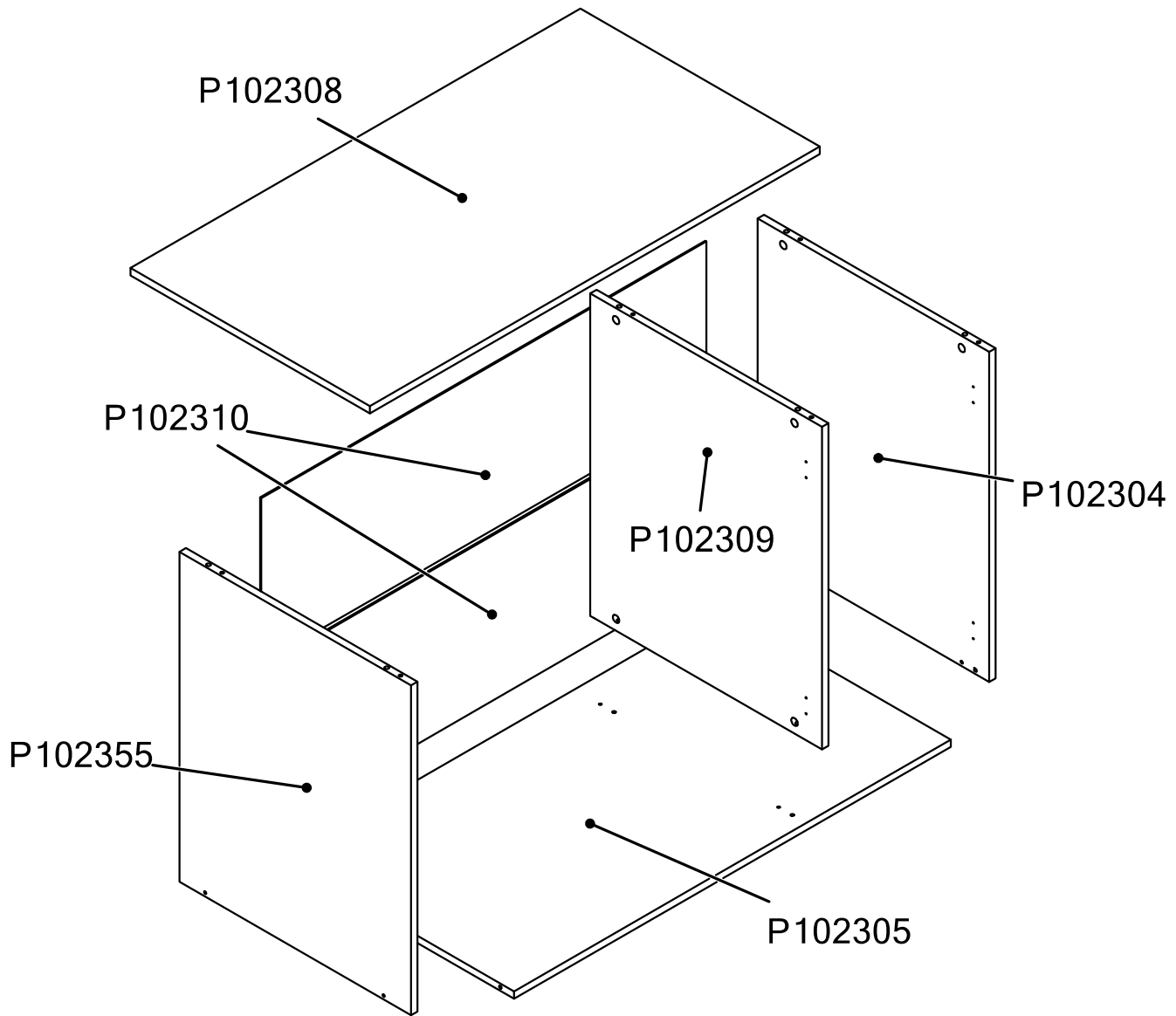









## IDENTIFICAÇÃO DOS ACESSÓRIOS / IDENTIFICACIÓN DE ACCESORIOS IDENTIFICATION OF ACCESSORIES

**NOTAS: A separação dos acessórios antes de iniciar a montagem facilitará a mesma. Em caso de dúvida na identificação, coloque o acessório sobre a régua.**

Nota: Separar los accesorios antes de iniciar el montaje facilitará el mismo. En caso de duda en la identificación, coloque el accesorio en la regla.

NOTE: Separating the accessories before starting assembly will make it easier. In case of doubt in the identification, place the accessory on the ruler.

	Quantidade / Cantidad / Amount	Código / Code	Descrição	Descripción	Description
	12	001802	CAVILHAS DE MADEIRA 6X30 PINUS	TARUGO 6X30MM	DOWEL 6X30MM
	8	030950	TAMBOR P/ MINIFIX 15MM ZAMAQ 09.11.007	CILINDRO 15MM	BARREL 15MM
	8	030945	PARAFUSO DE ACO P/ MINIFIX	TORNILLO DE ACERO PARA MINIFIX	STEEL SCREW FOR MINIFIX
	36	061971	P.PANELA 4,0 X 14 ZB P/DOBRADICA	TORNILLO 4,0 X 14	SCREW 4,0 X 14
	6	059614	DOBRAD. CURVA 35MM C/ CALCO FIXO E AMORTECEDOR	BISAGRA DE CALCE	HINGE AND SHIM
	38	000107	PREGO 10 X 10 (0,308G) LISO	CLAVO 10 X 10	NAIL 10 X 10
	1	PH	PERF. H26 1020MM BEGE	PERFIL H 1020MM	PROFILE H 1020MM
	8	19MM	TAPA FURO 19MM	TAPA DEL AGUJERO 19MM	SCREW CAP COVER 19MM

## IDENTIFICAÇÃO DOS ACESSÓRIOS / IDENTIFICACIÓN DE ACCESORIOS IDENTIFICATION OF ACCESSORIES

	5	054117	P.CHATO 3,5 X 25 CAB. PHILLIPS ZB/BC (IDELLI)	TORNILLO 3,5 X 25	SCREW 3,5 X 25
	4	000226	P.CHATO 4,0 X 40MM	TORNILLO 4,0 X 40MM	SCREW 4,0 X 40MM
	4	13MM	TAPA FURO 13MM	TAPA DEL AGUJERO 13MM	SCREW CAP COVER 13MM
	4	017024	SUP. AEREO METALICO ZINCADO BRANCO (04.08.150)	SUP. AEREO METALICO ZINCADO BRANCO (04.08.150)	SUP. AEREO METALICO ZINCADO BRANCO (04.08.150)
	8	004214	P.CHATO 3,5 X 14 CAB. PHILLIPS REBAIXADA ZB	TORNILLO 3,5 X 14MM	SCREW 3,5 X 14MM
	4	050311	P.FLANGE 5,0 X 65 CAB. PHILLIPS ZB/BC	TORNILLO 5,0 X 65	SCREW 5,0 X 65
	4	000529	BUCHAS NYLON MU 8 CINZA (2001003279)	CASQUILLO DE FIJACIÓN DE NYLON	NYLON FIXING BUSHING
	4	006959	CAPA P/SUP. AEREO METAL BRANCA 10.05.042 (005)	CUBIERTA DE SOPORTE	SUPPORT COVER

## INSTALAÇÃO MINIFIX

Identificar seta no corpo do tambor de minifix. A seta DEVE apontar para o buraco na borda do painel. Empurrar o tambor até o buraco.

## INSTALACIÓN DE LA LEVA

Identifique la flecha en los muertos de la leva. La flecha debe apuntar hacia el agujero en el borde del panel. Empuje la leva hasta el fondo del orificio.

## INSTALLING CAM

Identify arrow on head of cam. Arrow MUST point toward hole in edge of panel. Push cam all the way down into hole.

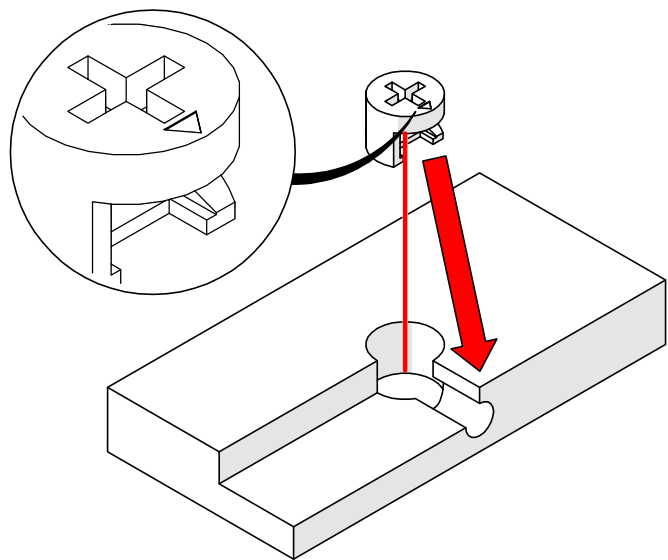

## ALINHAMENTO DO TAMBOR E PARAFUSO

A seta do tambor de minifix deve ser apontada para o buraco e inserir o parafuso do minifix do tambor contido no buraco. Certifique-se de que as peças se unam.

## ALINEACIÓN DE LA LEVA Y EL PASADOR

Asegúrese de que la flecha de la leva apunte hacia el orificio e inserte la clavija de la leva en el orificio. Asegúrese de que las piezas se unen.

## CAM AND DOWEL ALIGNMENT

Ensure the arrow on the cam points toward hole and insert cam dowel into hole. Make sure pieces join together.

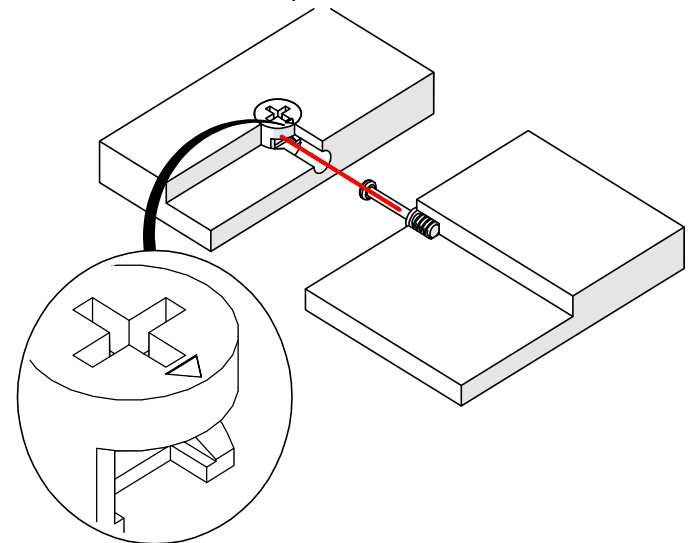

## CÂMARA DE COMPENSAÇÃO DE TENSÃO

Use uma chave de fenda para girar a came. Girar o tambor minifix (no sentido horário) até que esteja totalmente apertado. Ligeiramente mais de meia volta.

## APRIETE DE LA LEVA

Utilice un destornillador para girar la leva. Gire la leva (en el sentido de las agujas del reloj) hasta que esté completamente apretada. Un poco más de media vuelta.

## TIGHTENING CAM

Use screwdriver to turn cam. Turn cam (clockwise) until fully tightened. Slightly more than half a turn.

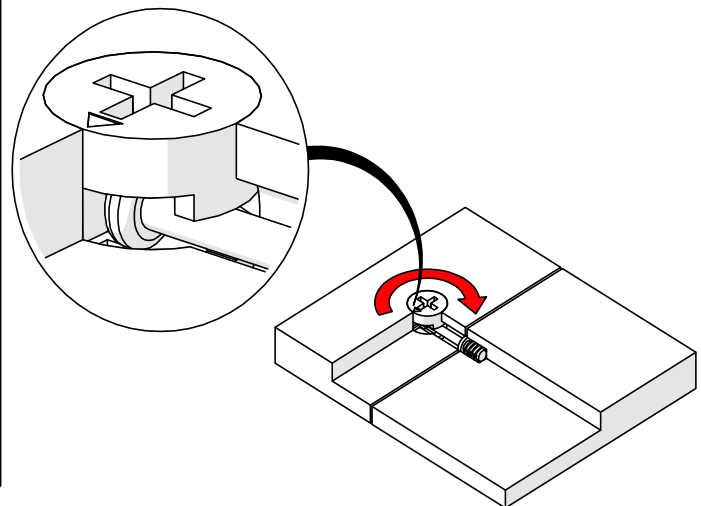

## PASSO / PASO / STEP 1

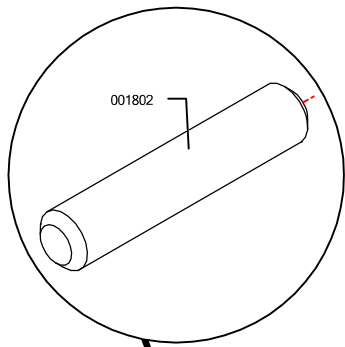

Cód.	Qtde.
001802	2

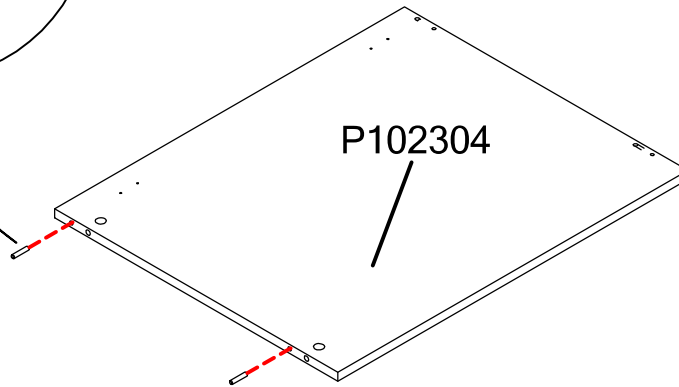

## PASSO / PASO / STEP 2

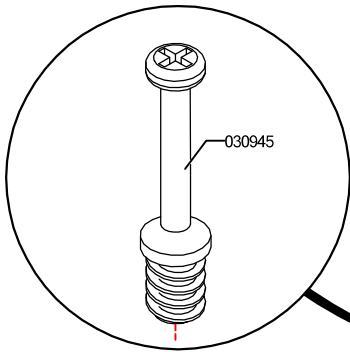

Cód.	Qtde.
001802	4
030945	2

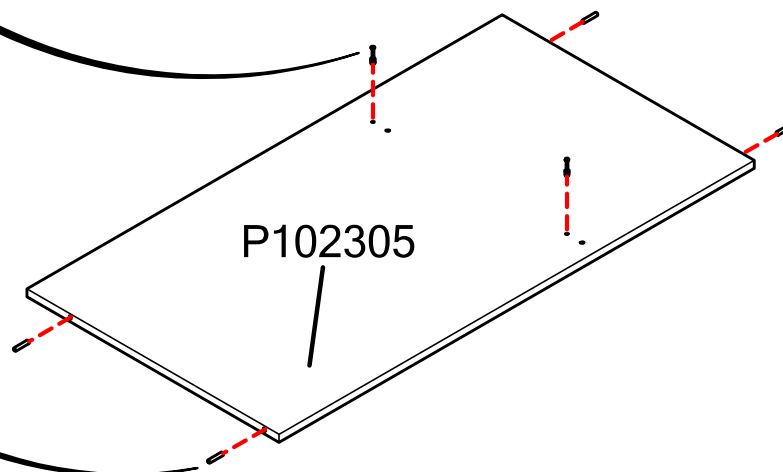
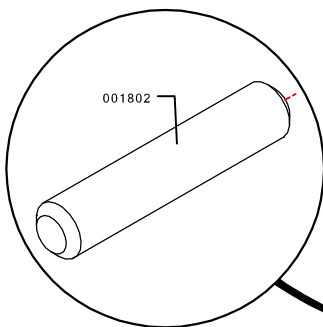



## PASSO / PASO / STEP 3

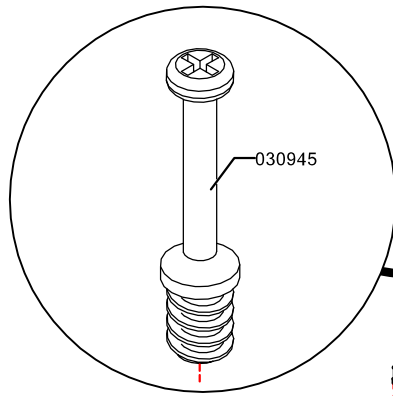

Cód.	Qtde.
030945	6

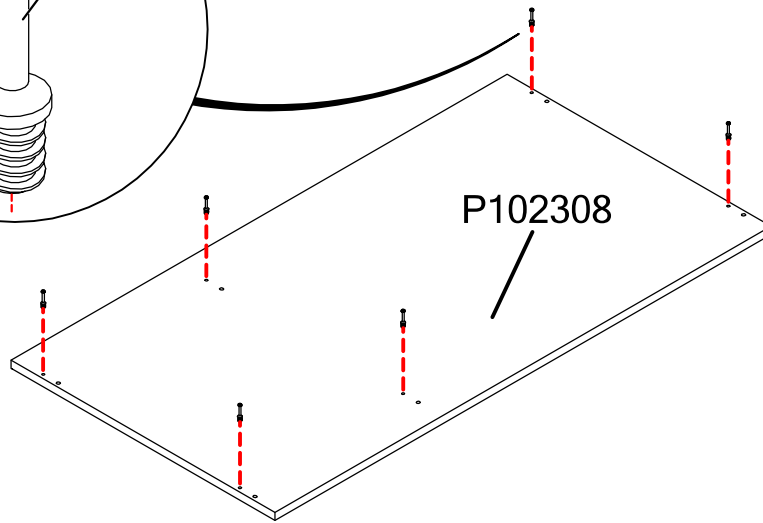

## PASSO / PASO / STEP 4

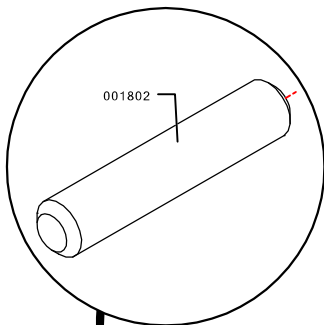

Cód.	Qtde.
001802	4

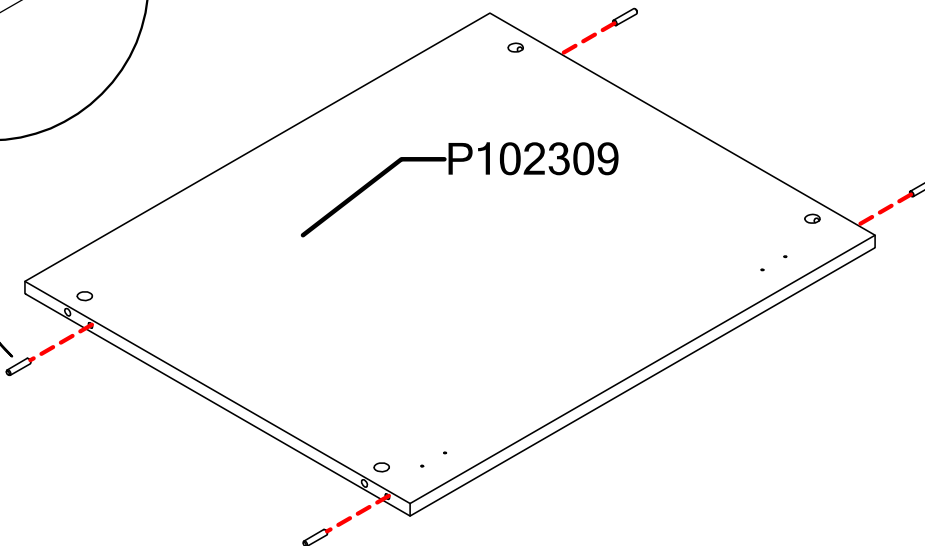

## PASSO / PASO / STEP 5

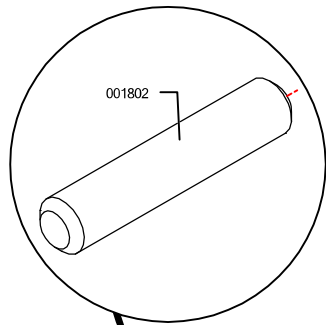

Cód.	Qtde.
001802	2

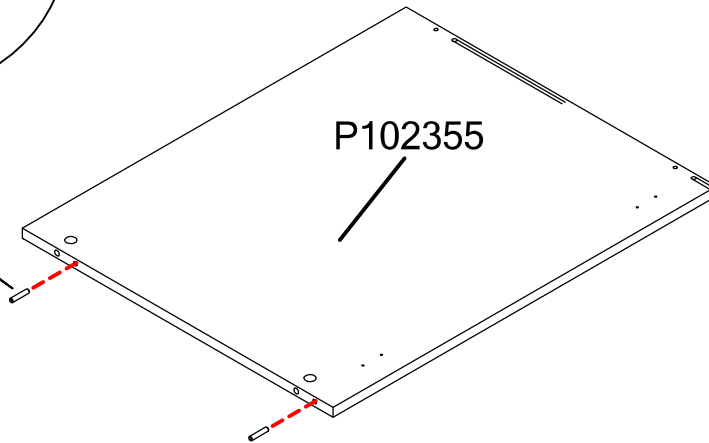

## PASSO / PASO / STEP 6

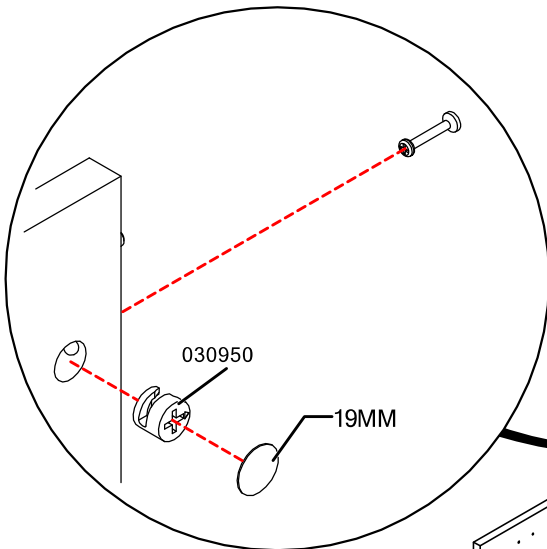

Cód.	Qtde.
030950	2
19MM	2

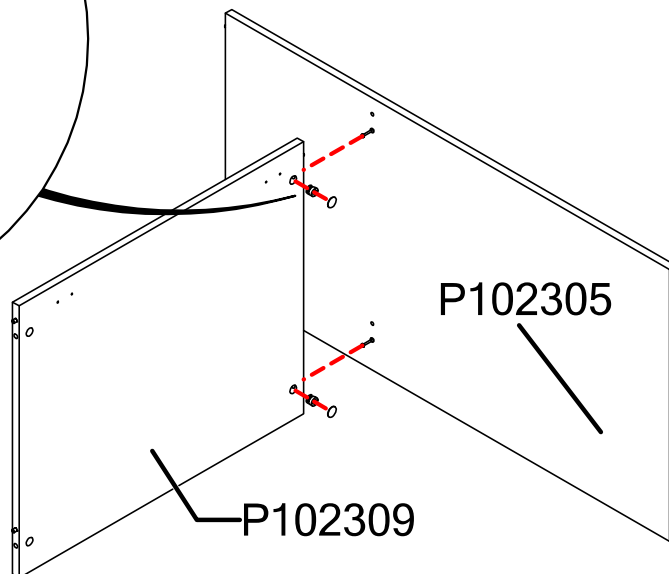

## PASSO / PASO / STEP 7

Cód.	Qtde.
000226	4
13MM	4

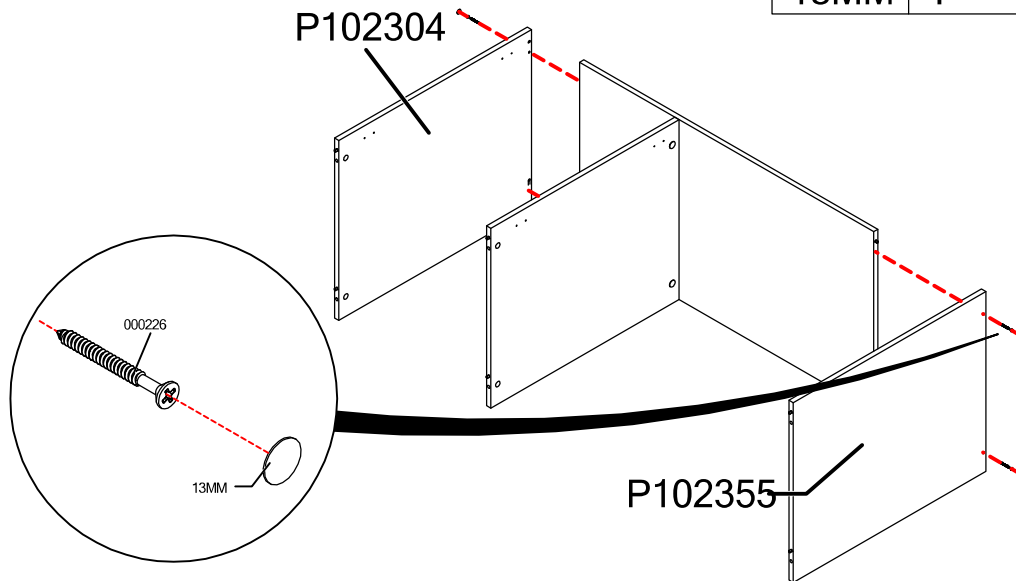

## PASSO / PASO / STEP 8

Cód.	Qtde.
030950	6
19MM	6

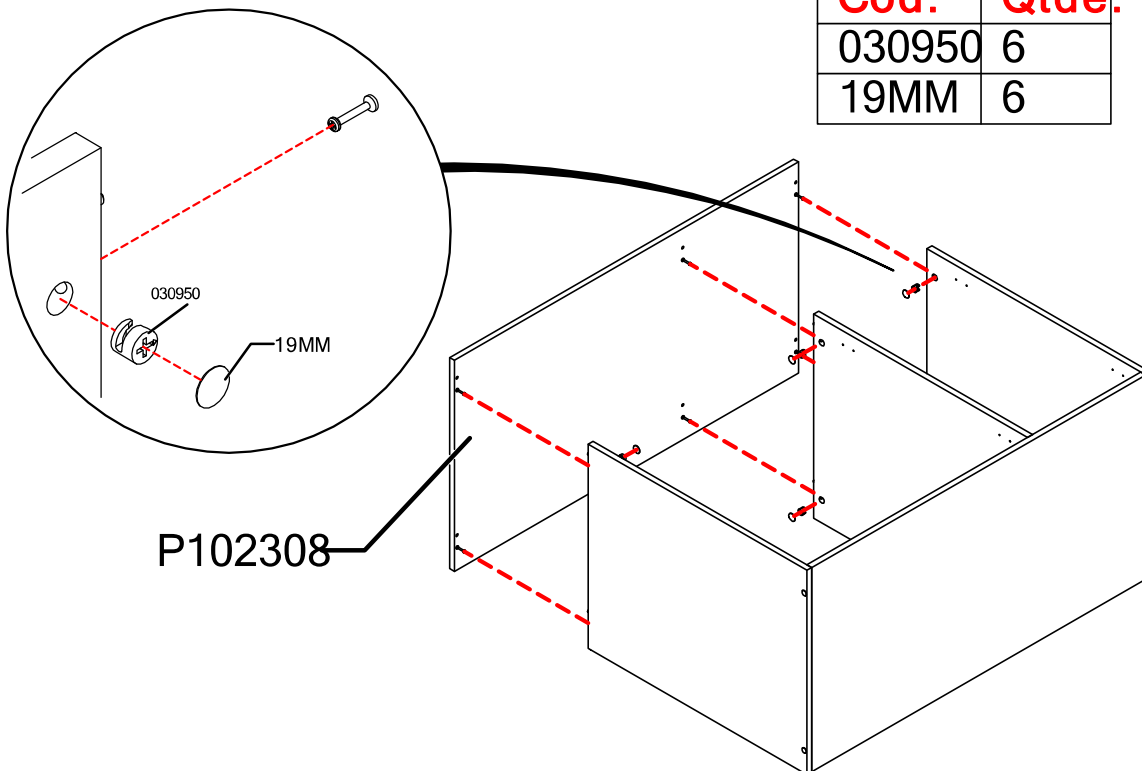

## PASSO / PASO / STEP 9

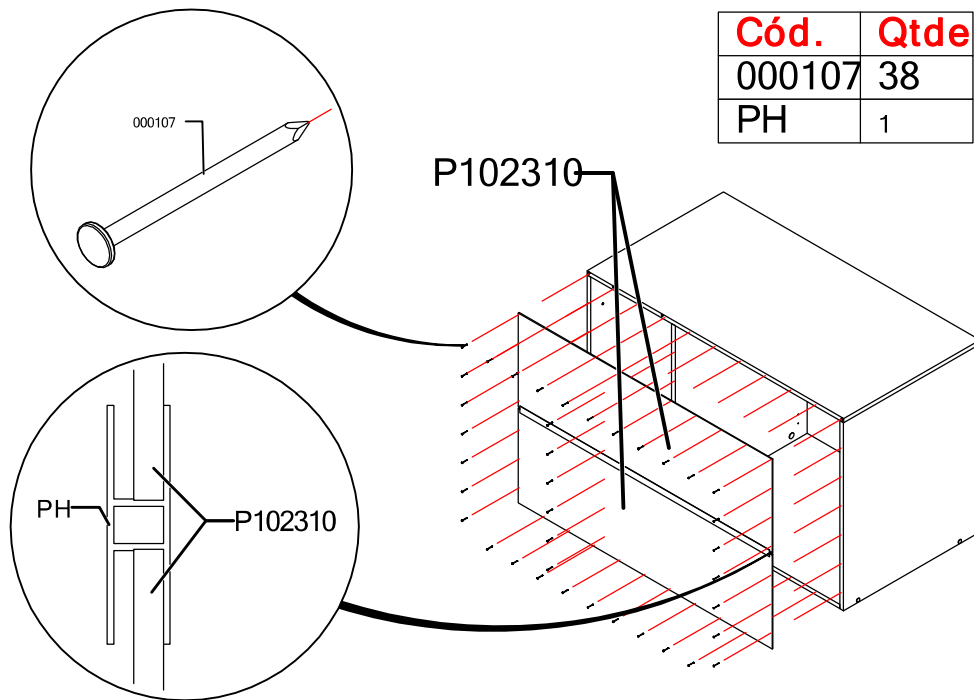

Cód.	Qtde.
000107	38
PH	1

## PASSO / PASO / STEP 10

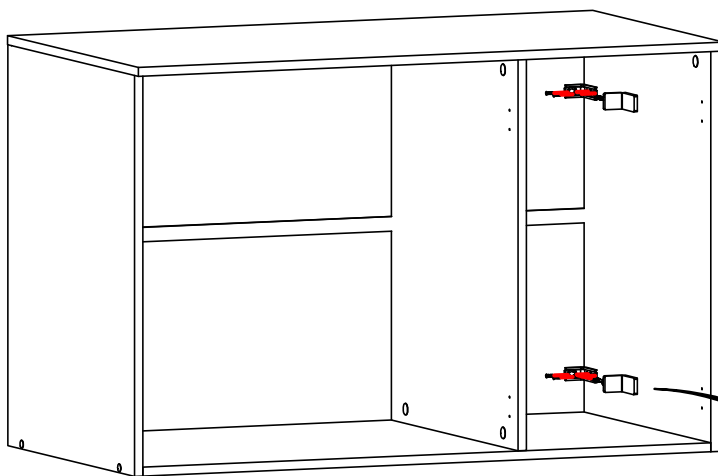

Cód.	Qtde.
000529	4
004214	8
006959	4
017024	4
050311	4

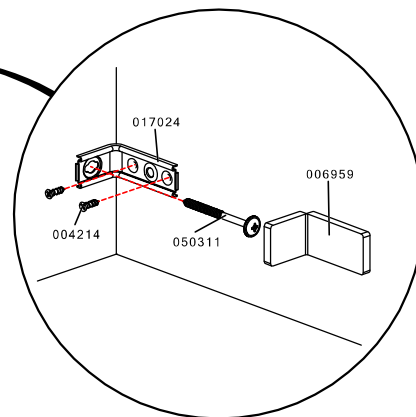

Cód.	Qtde.
059614	6
061971	36

