

Lista de Peças / List of pieces / Lista de piezas

Cód	DESCRIÇÃO	DESCRIPTION	DESCRIPCIÓN	QTD	RAW MATERIAL	DIMENSION	CÓD
01	Tampo	Top	Tapa	1	MDP 15mm	600x450x15mm	703639
02	Lateral Esquerda	Left Side	Lateral Izquierda	1	MDP 15mm	540x450x15mm	303639
03	Lateral Direita	Right Side	Lateral Derecha	1	MDP 15mm	540x450x15mm	313639
04	Base	Base	Base	1	MDP 15mm	600x450x15mm	103639
05	Costa	Back	Revés	2	MDP 03mm	590x280x03mm	403639
06	Frente de Gaveta	Drawer Front	Frente Cajón	2	MDP 15mm	562x265x15mm	83639
07	Lateral Gaveta Menor	Smaller Drawer Side	Lateral Cajón Menor	2	MDP 15mm	180x125x15mm	333607
08	Fundo de Gaveta Menor	Smaller Drawer Bottom	Fondo Cajón Menor	1	MDP 03mm	520x188x03mm	423639
09	Costa de Gaveta	Drawer Back	Revés Cajón	2	MDP 15mm	542x125x15mm	413639
10	Lateral Gaveta	Drawer Side	Lateral Cajón	2	MDP 15mm	298x125x15mm	323607
11	Fundo de Gaveta	Drawer Bottom	Fondo Cajón	1	MDP 03mm	520x306x03mm	421010

Notas Especiais:

01 -Examine completamente todas as peças do móvel antes de começar o trabalho.

02 -Recomenda-se montar o móvel conforme este Manual de Montagem.

03 -É de responsabilidade do montador seguir as instruções do Manual de Montagem, que são fundamentais para garantir a estrutura do móvel.

04 -Para limpeza, utilizar somente pano úmido e sabão neutro.

Special notes:

01 -Check all parts of the unit thoroughly before starting work.

02 -It is recommended to assemble the furniture according to this Installation Manual.

03 -It is the responsibility of the assembler to follow the instructions in the Assembly Manual, which are essential to ensure the structure of the furniture.

04 -For cleaning use only damp cloth and neutral soap.

Notas especiales:

01 -Examine completamente todas las piezas del mueble antes de iniciar el trabajo.

02 -Se recomienda montar el mueble conforme el Manual de Ensamblaje.

03 -Es de responsabilidad del montador seguir las instrucciones del Manual de Ensamblaje, que son fundamentales para garantizar la estructura del mueble.

04 -Para limpieza solamente usar trapo húmedo y jabón neutro.

Guarante certificate:

The guarantee of products manufactured by Móveis Videira LTDA covers any defects / manufacturing defects, within the period established by the Consumer Protection Code, in its Article 26, II, which provides for a legal guarantee of ninety (90) days.

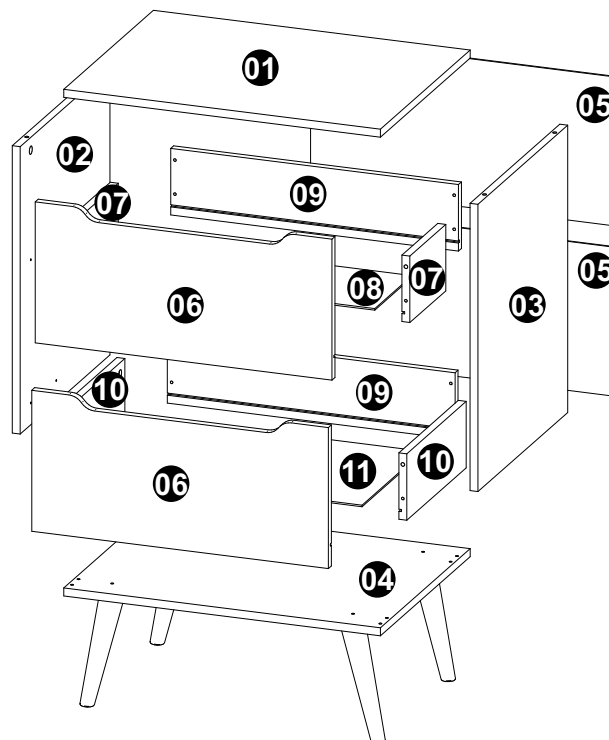

TAMANHO REAL - TAMAÑO VERDADERO - REAL SIZE

REF	DESCRIÇÃO	QTD	CÓD
A	3,5 x 14mm CC	14	3639
B	Cavilha 5 x 30mm	12	3880
C	3,5x40mm CC	04	8115

ILUSTRAÇÃO - ILUSTRACION - ILLUSTRATION

REF	DESCRIÇÃO	QTD	CÓD
D	Parafuso 5 x 50mm CF	02	2263
E	Corrediça 250mm	01	
F	Corrediça 300mm	01	
G	22 x 3mm Prego 10x10	18	3051
H	Parafuso 3,5x12 CF	08	
I	Parafuso 3,5x16 CF	16	3841
J	Pé PVC 230mm	04	
K	34x7mm Parafuso minifix	12	3771
L	15x12mm Tambor minifix	12	9516
M	5,0x40mm CC	04	4000
N	Cantoneira com capa 43x43x25mm	02	5630
O	40x8mm Buchá 8mm	02	5623

Ferramentas | Tools | Herramientas

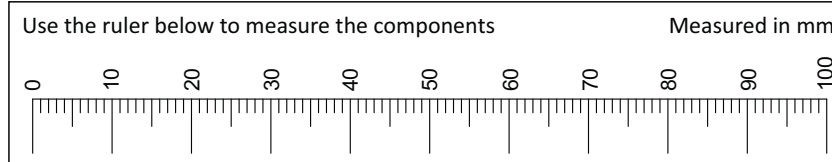
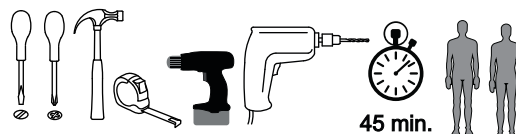

1

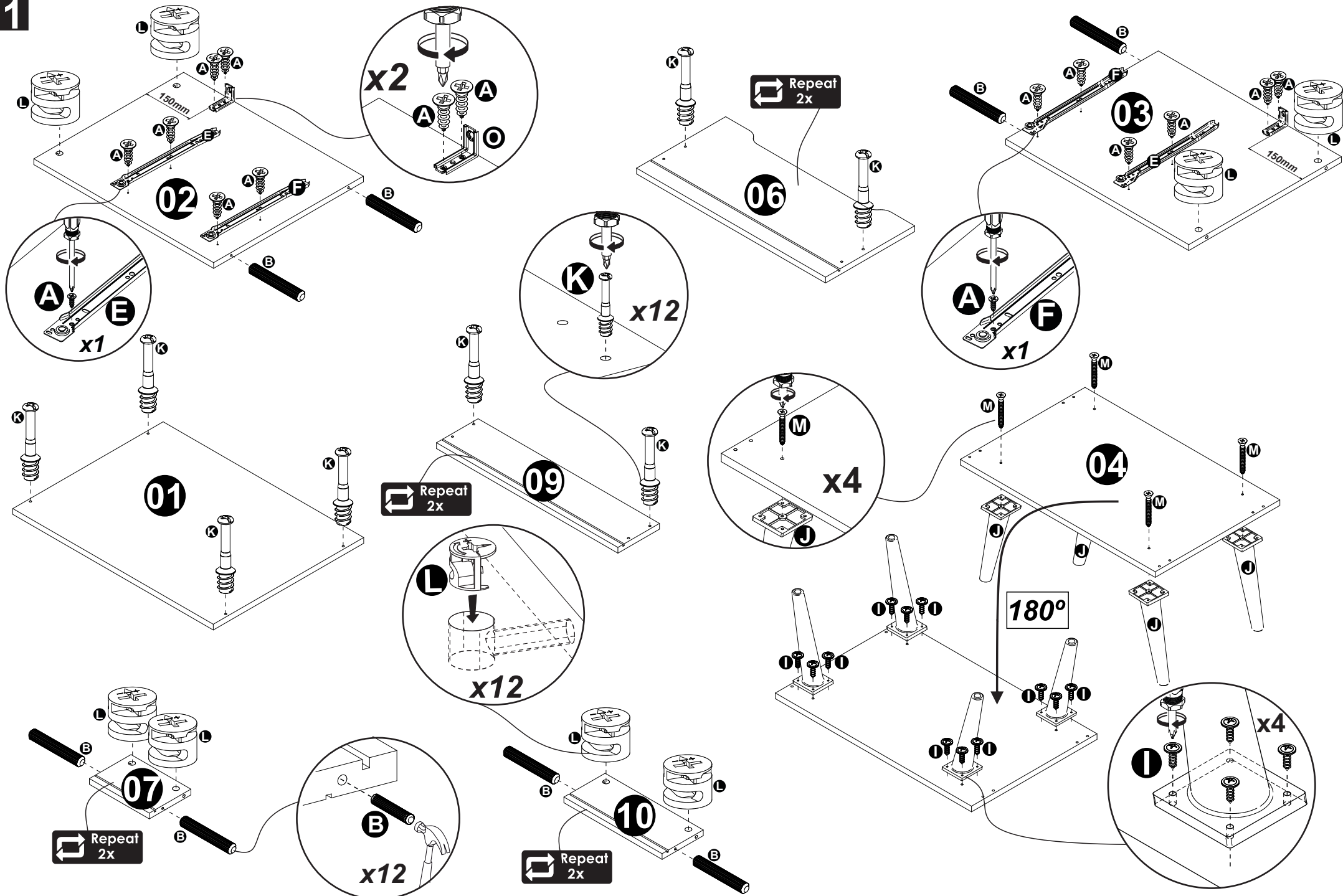

2

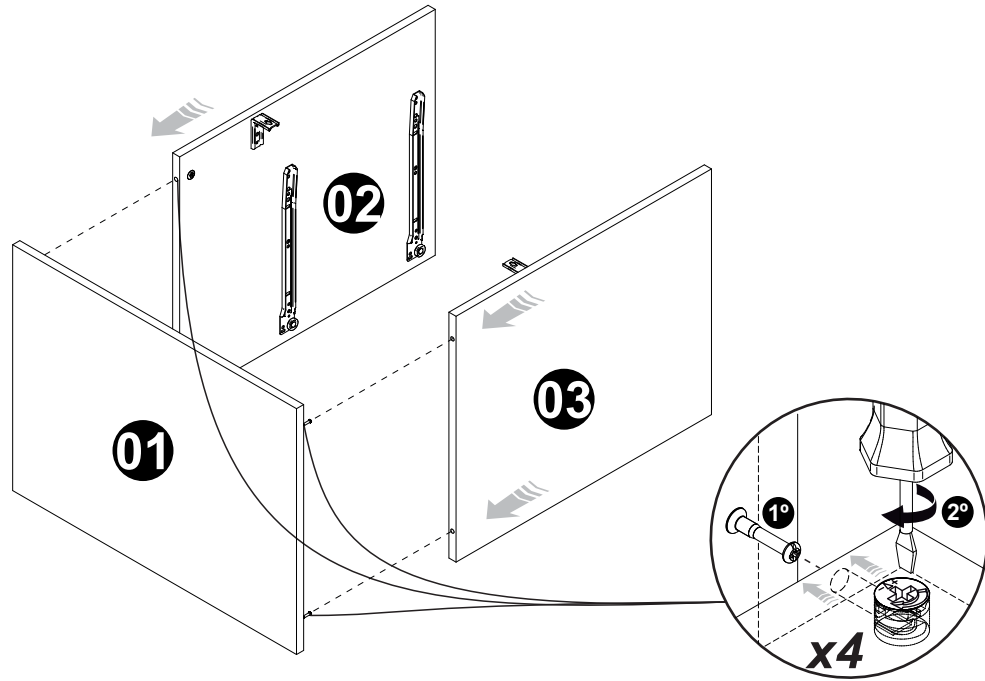

3

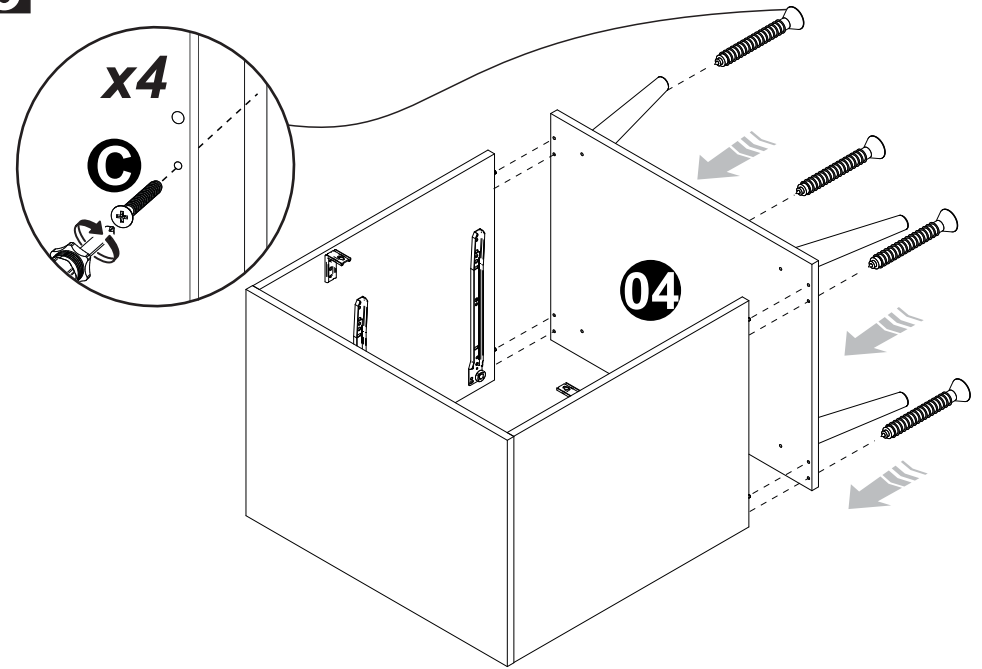

4

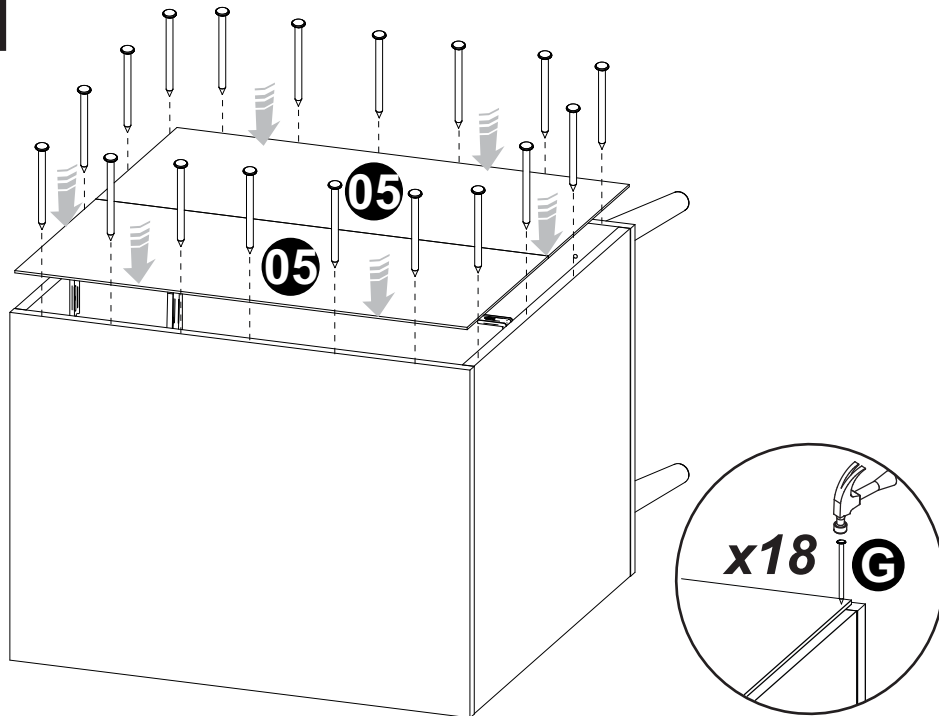

5

