



**MANUAL DE MONTAGEM  
ASSEMBLY INSTRUCTIONS  
INSTRUCCIONES DE MONTAJE**

**COD BR: BF 11**



# Sumário Summary Resumen

Introdução Introduction Introducción	.....	3
Antes de começar Before starting Antes de comenzar	.....	4
Evite acidentes Avoid accidents Evitar accidentes	.....	4
Dimensões e ferramentas Dimensions and tools Dimensiones y herramientas	.....	5
Identificação das peças Identifying parts Identificación de las piezas	.....	6
Acessórios incluídos na caixa Hardware included in box Accesorios incluidos en la caja	.....	7
Montagem do móvel Furniture assembly Montaje del mueble	.....	8

## Introdução Introduction Introducción

Leia atentamente este manual e siga os passos indicados para que o produto não perca a garantia e também para uma perfeita montagem.

Read this manual and follow the steps in order to keep the guarantee and also for the perfect fit.

Lea este manual y siga los pasos para que el producto no pierda la garantía y también para el ajuste perfecto.

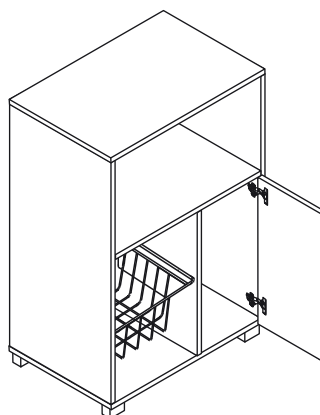

## Antes de começar Before starting Antes de comenzar

Antes de começar a montagem prepare o ambiente, deixando-o completamente limpo e com bom espaço para iniciar o trabalho.

Prepare the room before starting the assembly, leaving it completely clean and the area in good condition to start the work.

Antes de comenzar el montaje preparar el ambiente, dejándolo completamente limpio y con bueno espacio para comenzar el trabajo.

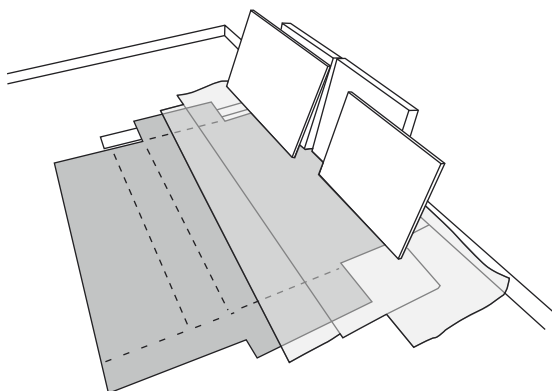

Utilize o papelão da própria embalagem para separar e apoiar as peças retiradas das caixas.

Use the cardboard of the packaging to separate and support the parts removed from the boxes.

Utilice el cartón de la embalaje para separar y apoyar las piezas desmontadas de las cajas.



Forre a área de montagem com um cobertor ou tapete. Assim, você evita avarias nas peças durante o processo de montagem.

Cover the assembly area with a blanket or carpet to avoid damaging the parts during the assembly process.

Cubrir la zona de ensamble con una manta o alfombra. De este modo, se evitan daños en las piezas durante el proceso de montaje.



## Evite acidentes Avoid accidents Prevenir accidentes

Solicitamos observar atentamente as orientações de montagem como: fixação do produto na parede, colocação de cola em locais específicos necessários, o peso suportado pelo produto, etc...

We request you to carefully observe the assembly instructions as: fixing the product on the wall, adding glue in needed and specific places, product weight limit, etc.

Pedimos que lea atentamente las instrucciones, principalmente las informaciones de fijación del producto en la pared, colocación de pegamento en local específico y necesario, el peso soportado por

Não escale ou se apoie no móvel.

Do not climb or lean on the furniture.

No se suba ni se apoye en el mueble.

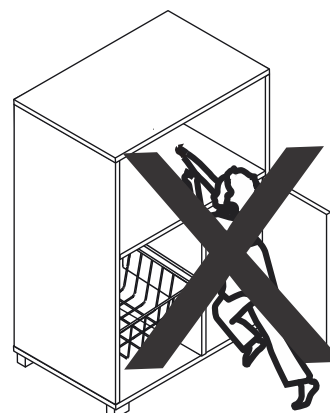

Dimensões e ferramentas  
Dimensions and tools  
Dimensiones y herramientas

Dimensões:

L: 540 A: 800 P: 355 mm

Dimensions:

W: 21.25 H: 31.49 D: 13.97 inches

Dimensiones:

L: 540 A: 800 P: 355 mm



Espaço para forno:

L: 510 A: 295 P: 340 mm

Oven space:

W: 20.07 H: 11.61 D: 13.38 inches

Espacio para el horno:

L: 510 A: 295 P: 340 mm

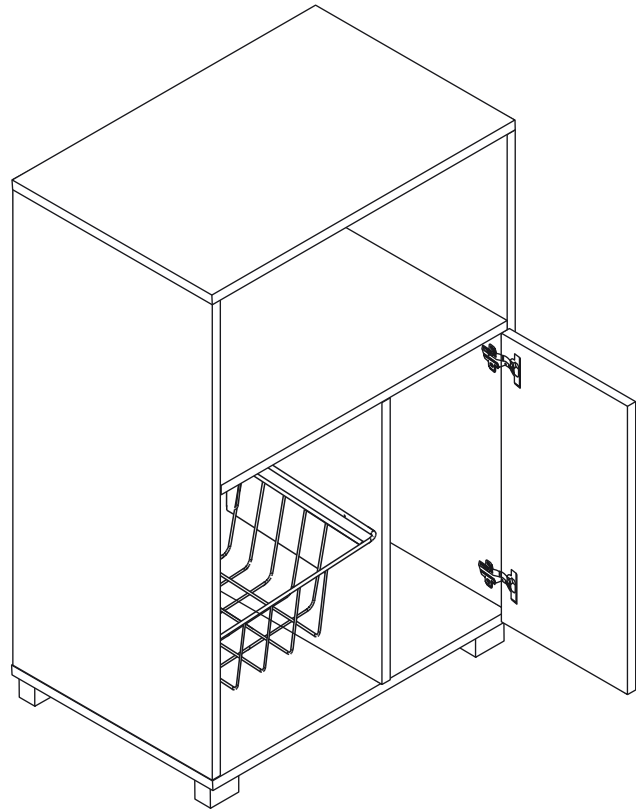

Limpeza  
Cleanig  
Limpieza



Pano levemente umedecido com água, seguido de pano seco, não utilizar produtos químico ou abrasivos.  
Slightly dampened cloth and after a dry cloth, do not use chemicals or abrasives.  
Solamente utilizar un paño húmedo y después un paño seco, no utilice productos químicos o abrasivos.

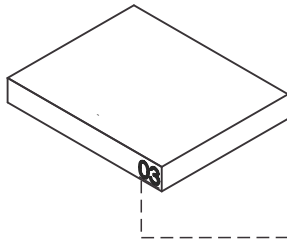

**UTILIZE ALCOOL APENAS PARA REMOVER O NUMERO DAS PEÇAS**  
**USE ALCOHOL ONLY TO REMOVE PART NUMBERS**

**UTILICE ALCOHOL SOLAMENTE PARA ELIMINAR EL NUMERO DE LAS PIEZAS**

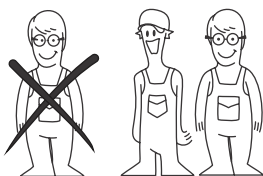

Para facilitar a montagem, utilize uma parafusadeira elétrica.  
To improve assembly, use an eletronic screwdriver.  
Para facilitar el armado, utilice un destornillador eléctrico.

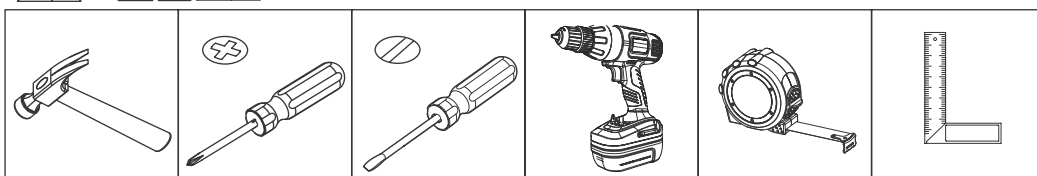

# COD BR: BF 11

PEÇA	DESCRIÇÃO	QUANT.
001	LATERAL DIREITA	1
002	LATERAL ESQUERDA	1
003	TAMPO	1
004	PRATELEIRA	1
005	COSTA	1
006	PORTA	1
007	BASE	1
008	DIVISÓRIA	1

PART	DESCRIPTION	QTY
001	RIGHT SIDE	1
002	LEFT SIDE	1
003	TOP	1
004	SHELF	1
005	BACK	1
006	DOOR	1
007	BASE	1
008	PARTITION	1

PIEZA	DESCRIPCIÓN	CANTIDAD
001	LATERAL DERECHA	1
002	LATERAL IZQUIERDA	1
003	TAPA	1
004	REPISA	1
005	REVÉS	1
006	PUERTA	1
007	BASE	1
008	PARTICIÓN	1

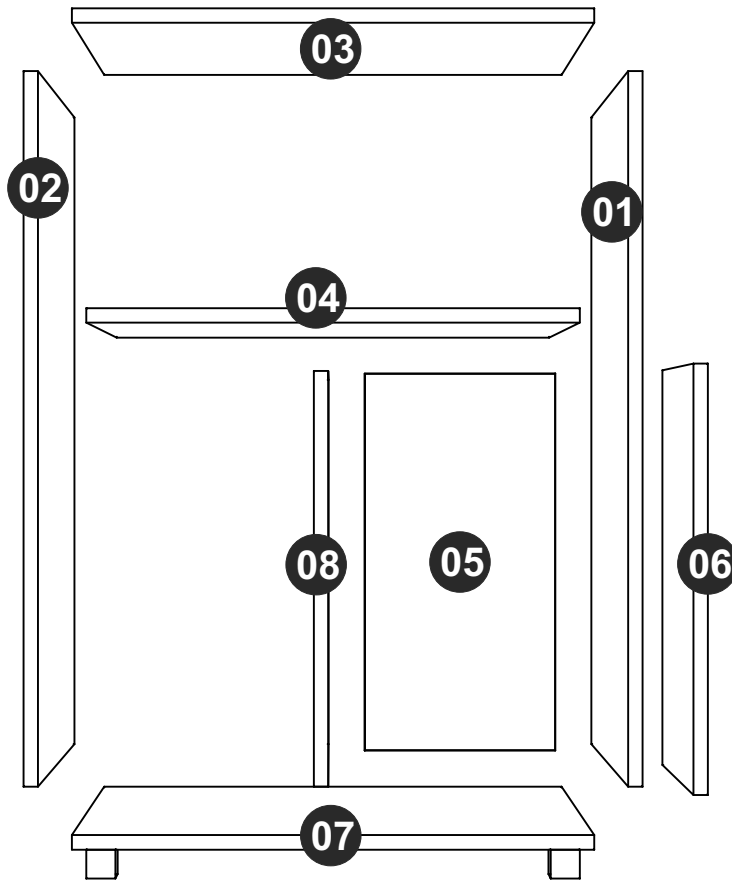



EF 000094 X 2

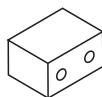

PÉS x 4  
FEET x 4  
PIES x 4



EF 000106 x 12  
3,5X14 CC



EF 000033 x 16



EF 000168 X 15  
10X10 C/C



EF 000216 X 2



EF 000008 X 1



GIZ x 01  
CHALK x 01  
TIZA x 01



EF 000132 X 5  
4X50 CC



EF 000024 X 2

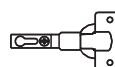

EF 000044 X 2



EF 000113 x 1  
3,5X30 CF



PUXADOR x 1  
HANDLE x 1  
MANIJA x 1



EF 000683 x 4



EF 000404 x 8  
3,5X 24 CC

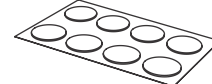

TAPA FUROS x 2  
STICKER x 2  
TAPAS PLÁSTICAS x 2



CESTA x 1  
BASKET x 1  
CESTA x 1

Utilize para medir as ferragens.

Utilice para medir el herraje.

Use for measuring the hardware.

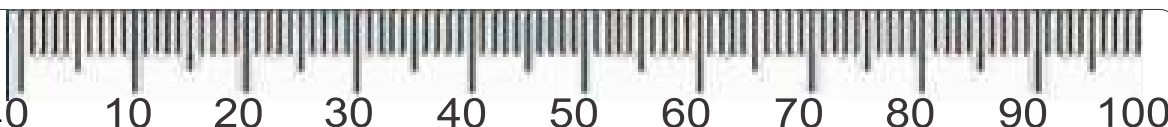

**Garantia (exclusivo para o Brasil/exclusivo de Brasil/exclusive to Brazil):**

A garantia dos produtos fabricados pela BRV Móveis, abrange eventuais defeitos-vícios de fabricação, no prazo estabelecido pelo código de Defesa do Consumidor, em seu artigo 26.II. o qual prevê a garantia de 90 (noventa) dias.

**A** = 7KG - 15.43LB

**B** = 6KG - 13.22LB

**C** = 2KG - 4.40LB

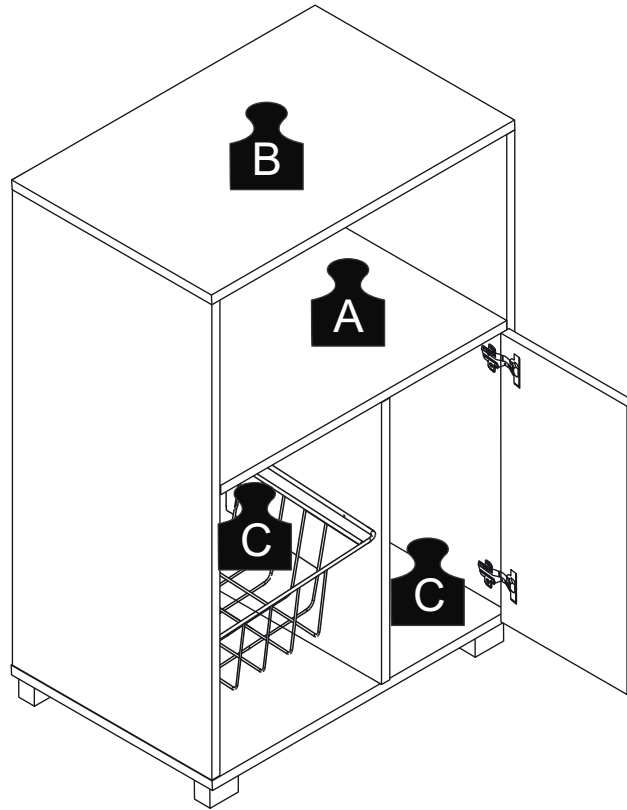

**PASSO 1 / STEP 1 / PASO 1**

Insira a ferragem EF 000033 na peça 02, 04 e 08.  
Insert hardware EF 000033 in piece 02, 04 and 08.  
Añade el herraje EF 000033 en la pieza 02, 04 y 08.

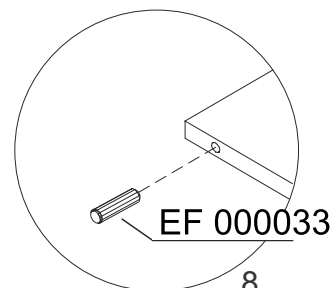
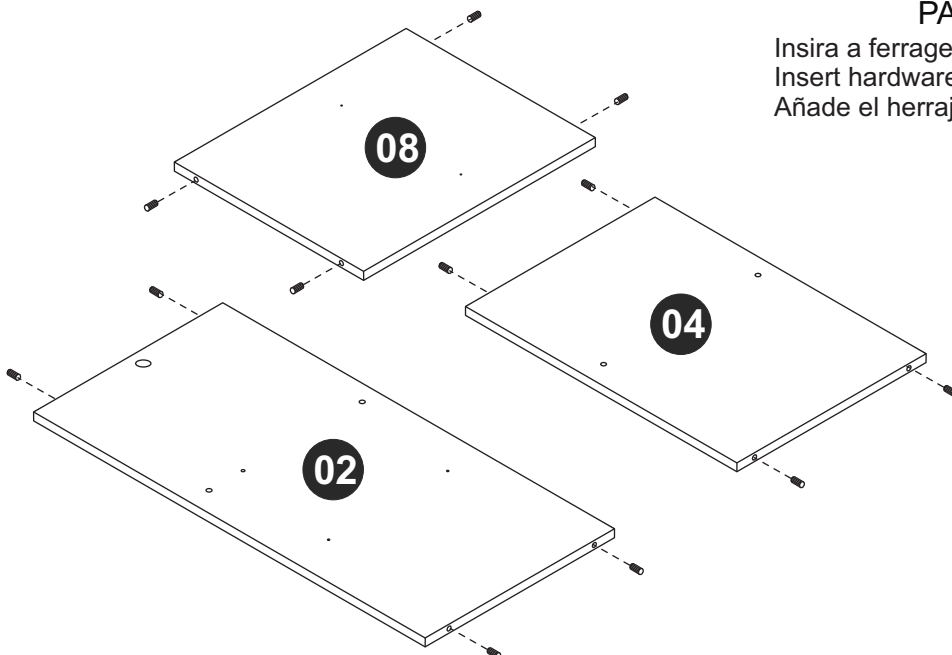



### PASSO 1 / STEP 1 / PASO 1

Fixe a ferragem EF 000024 usando a ferragem EF 000106 na peça 04.  
Fix hardware EF 000024 using hardware EF 000106 into piece 04.  
Fije el herraje EF 000024 utilizando el herraje EF 000106 en la pieza 04.

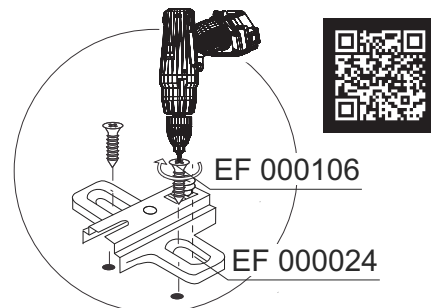
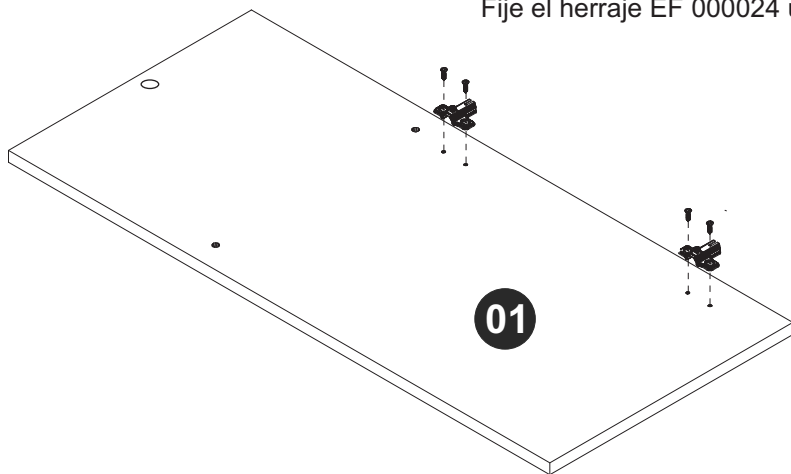

### PASSO 2 / STEP 2 / PASO 2

Fixe a ferragem EF 000044 na peça 06 utilizando a ferragem EF 000106.  
Fixe o puxador usando a ferragem EF 000113.  
Attach hardware EF 000044 on piece 06 using hardware EF 000106. Attach the handle using hardware EF 000113.  
Fije el herraje EF 000044 en la pieza 06 utilizando el herraje EF 000106.  
Fije la manija utilizando el herraje EF 000113.

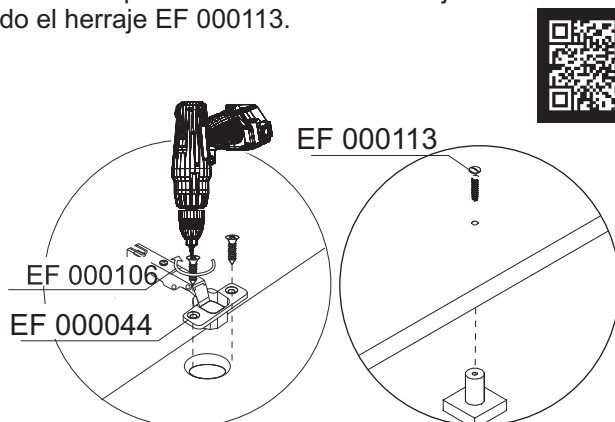
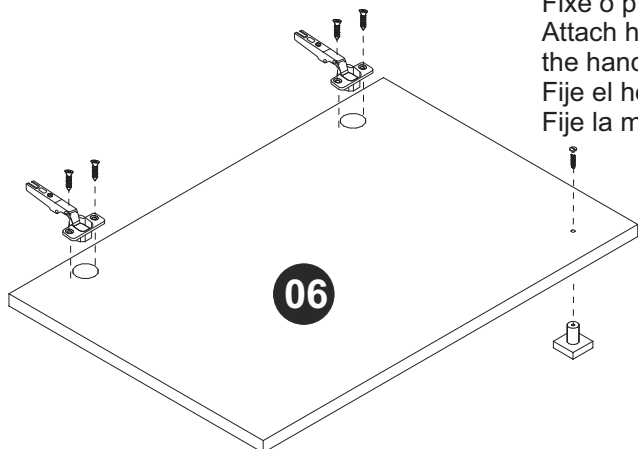

### PASSO 3 / STEP 3 / PASO 3

Fixe a ferragem EF 000094 na peça 03.  
Fix hardware EF 000094 in piece 03.  
Fije el herraje EF 000094 en la pieza 03.

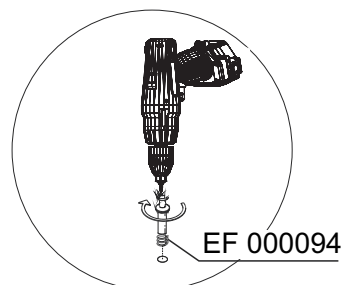
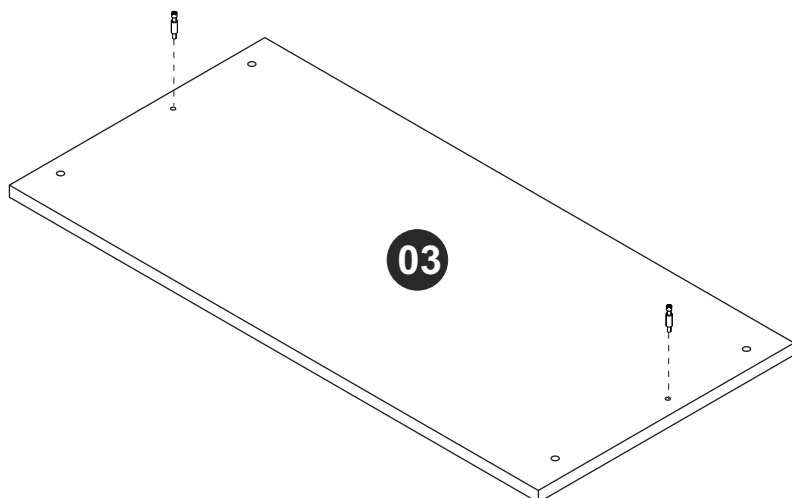

### PASSO 5 / STEP 5 / PASO 5

Conecte as peças 01, 02, 04 e 08, utilizando a ferragem EF 000132.  
Connect pieces 01, 02, 04 and 08, using hardware EF 000132.  
Junte las piezas 01, 02, 04 y 08, utilizando el herraje EF 000132.

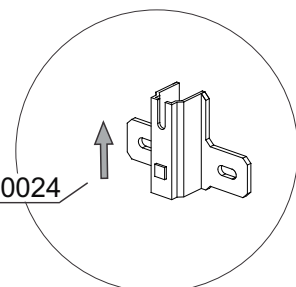
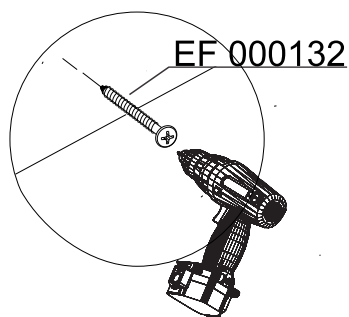
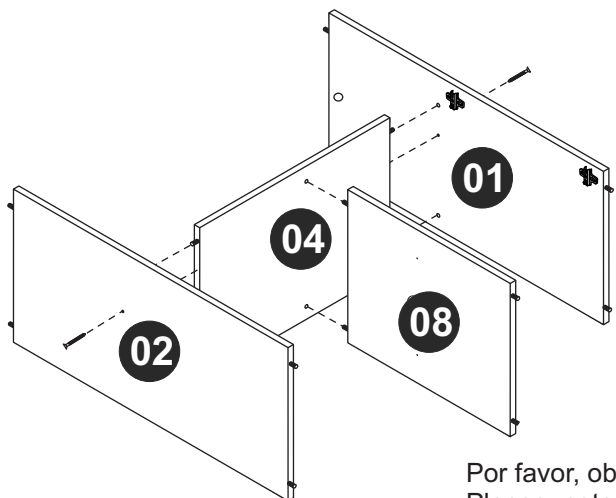

Por favor, observe a posição da ferragem EF 000024  
Please, note hardware EF 000024 position.  
Por favor, observe la posición del herraje EF000024.

### PASSO 6 / STEP 6 / PASO 6

Conecte a peça 03, insira a ferragem EF 000216 e gire para apertar.  
Connect piece 03, insert hardware EF 000216 and turn to tighten.  
Junte la pieza 03, añáde el herraje EF 000216 y gire para apretar.

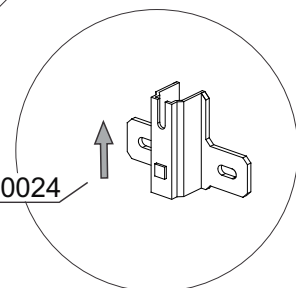
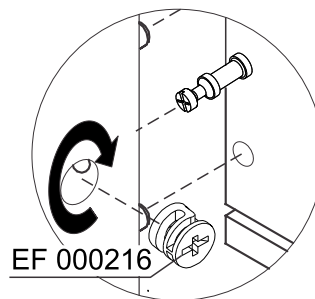
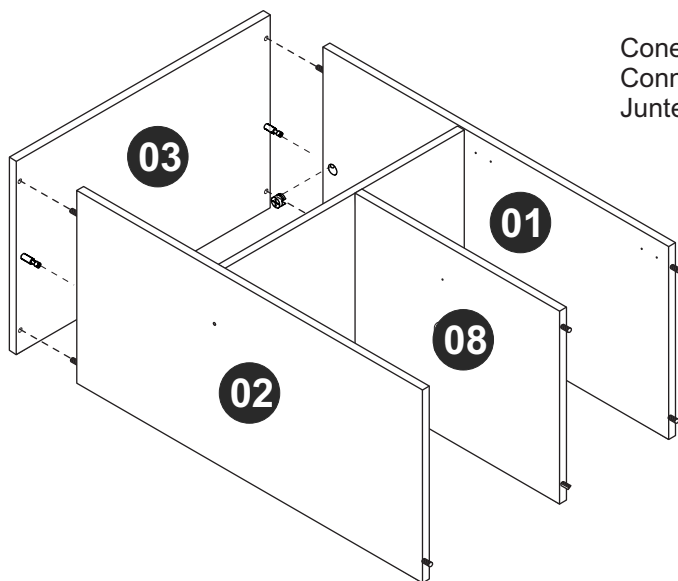

Por favor, observe a posição da ferragem EF 000024  
Please, note hardware EF 000024 position.  
Por favor, observe la posición del herraje EF000024.

### PASSO 7 / STEP 7 / PASO 7

Conecte a peça 07 utilizando a ferragem EF 000132.  
Connect pieces 07 using hardware EF 000132.  
Junte la pieza 07 utilizando el herraje EF 000132.

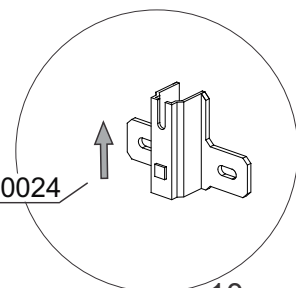
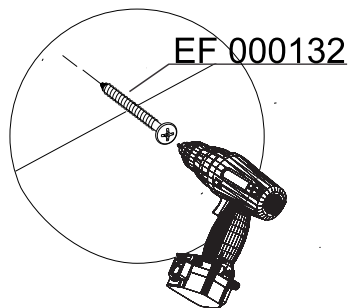
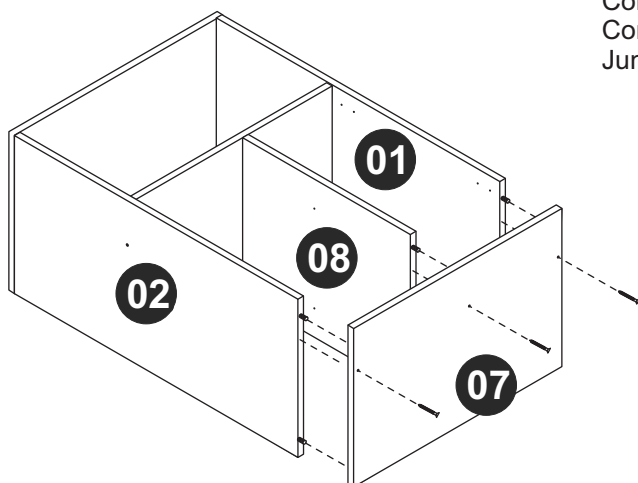

Por favor, observe a posição da ferragem EF 000024  
Please, note hardware EF 000024 position.  
Por favor, observe la posición del herraje EF000024.

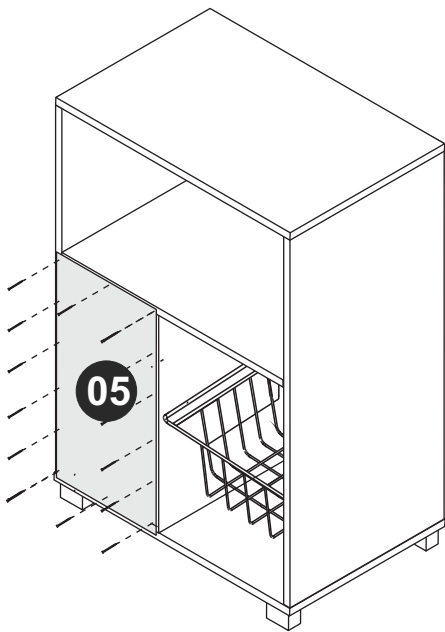

### PASSO 8 / STEP 8 / PASO 8

Fixe a peça 05 ao móvel utilizando a ferragem EF 000168.  
Fix piece 05 at the furniture using hardware EF 000168.  
Fije la pieza 05 al mueble utilizando el herraje EF 000168.

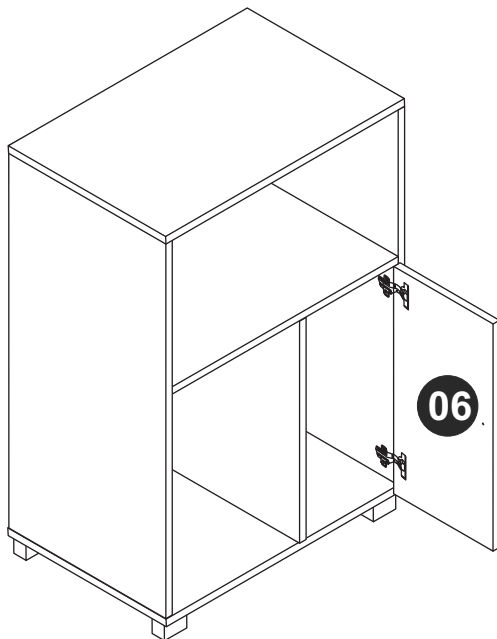
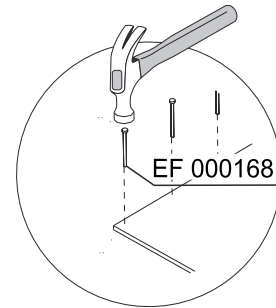

### PASSO 9 / STEP 9 / PASO 9

Conecte a peça 06 ao móvel montado.  
Connect piece 06 to the assembled furniture.  
Junte la pieza 06 al mueble armado.

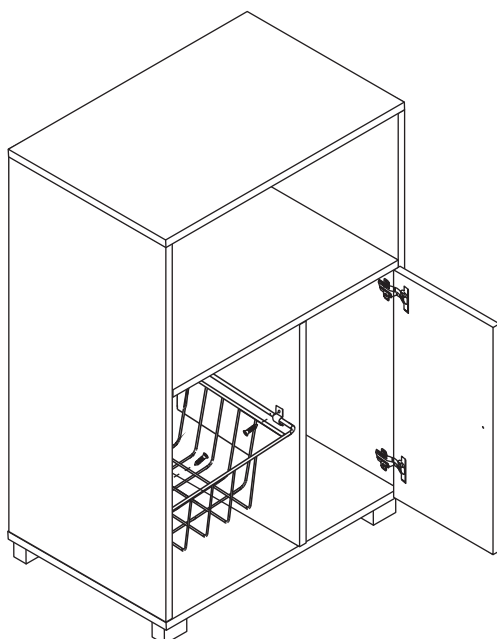
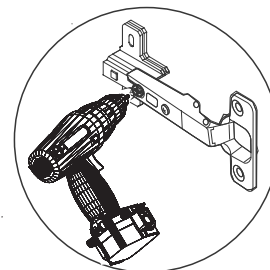

### PASSO 10 / STEP 10 / PASO 10

Utilize as ferragens EF 000683 e EF 000106 para fixar a cesta.  
Use hardware EF 000683 and EF 000106 to attach the basket.  
Utilice los herrajes EF 000683 y EF 000106 para fijar la cesta.

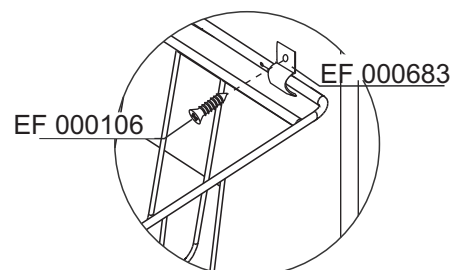

## PASSO 11 / STEP 11 / PASO 11

Use os tapa furos para cobrir os parafusos aparentes.  
Use o giz para dar o acabamento final ao produto.  
Use stickers to cover apparent screws.  
Use the chalk to give the final finish on the product.  
Utilice los tapa huecos para cubrir los tornillos aparentes.  
Utilice la tiza para dar el acabado final al producto.

