

# kappesberg

A montagem deve ser efetuada por UMA pessoa.  
El montaje debe ser efectuado por UNA persona.  
The assembly must be done by ONE people.

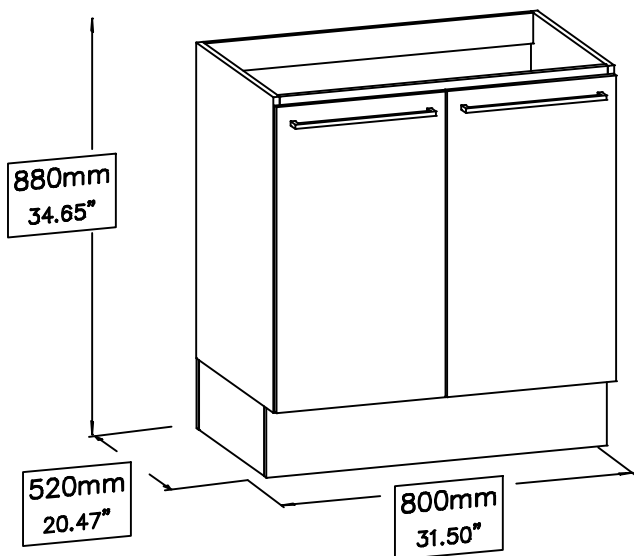

Ferramentas necessárias para montar o móvel  
Herramientas necesarias para armar el mueble.

Tools needed to assemble the furniture.

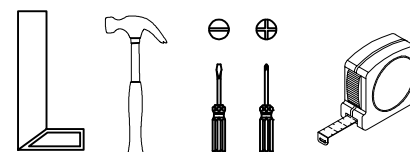

Montar o móvel sobre uma superfície limpa e plana

Armar el mueble sobre una superficie limpia y plana

Assemble the furniture on a clean and flat surface

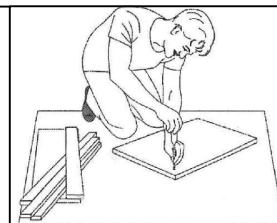

Lista de peças / Lista de piezas / List of pieces

Código / Code	Descrição	Descripción	Description	Quantidade / Cantidad / Amount	Comprimento / Longitud / Length (mm)	Comprimento / Longitud / Length (in.)	Largura / Ancho / Width (mm)	Largura / Ancho / Width (in.)	Espesura / Espesor / Thickness (mm)	Espesura / Espesor / Thickness (in.)	Caixa / Caja / Box
01	Lateral direita	Lateral derecha	Right side	1	720	28.35"	496	19.53"	15	.59"	A
02	Lateral esquerda	Lateral izquierda	Left side	1	720	28.35"	496	19.53"	15	.59"	A
03	Base	Pieza de suelo	Base	1	770	30.31"	496	19.53"	15	.59"	A
04	Prateleira	Estantería	Shelf	1	770	30.31"	430	16.93"	15	.59"	A
05	Travessa	Travesaño	Cross-piece	2	770	30.31"	70	2.76"	15	.59"	A
06	Rodapé lateral	Falda lateral	Side Skirting	2	420	16.54"	160	6.30"	15	.59"	A
07	Rodapé	Zócalo	Baseboard	2	799	31.46"	160	6.30"	15	.59"	A
08	Costas	Pieza del fondo	Back panel	2	790	31.10"	335	13.19"	3	.12"	A
09	Porta	Puerta	Door	2	698	27.48"	396	15.59"	15	.59"	A

# M623

**IDENTIFICAÇÃO DAS PEÇAS/ IDENTIFICACIÓN DE LAS PIEZAS/ PARTS IDENTIFICATION**

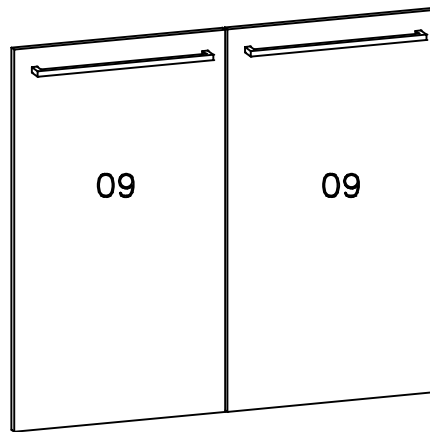
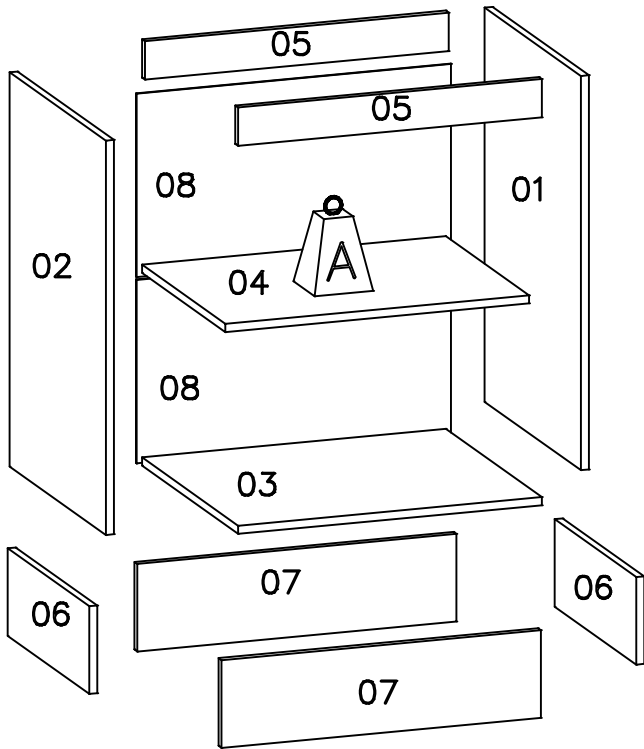
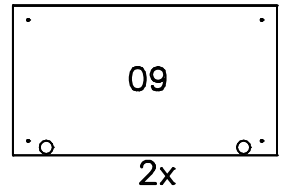
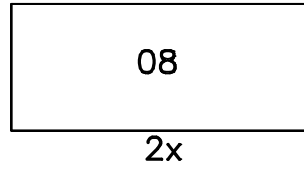
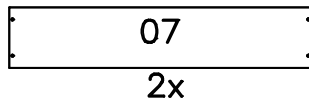
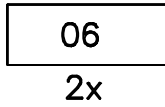
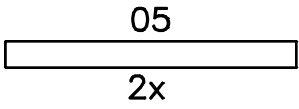
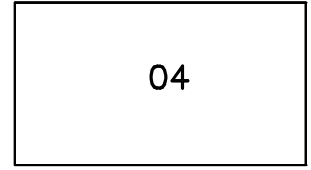
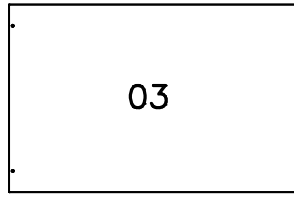
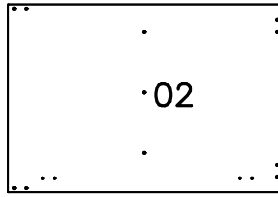
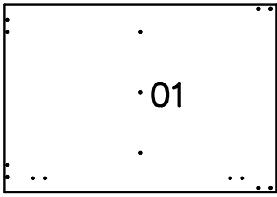

Dúvidas? entrar em contato:  
¿Dudas? Ponerse en contacto:  
Doubts? Get in touch:

Fone: (51) 3635-8839  
www.kappesberg.com.br

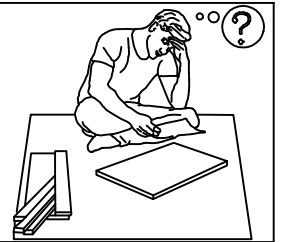

	Kg	lb
A	7	15.43lb

## M623

## IDENTIFICAÇÃO DOS ACESSÓRIOS/ IDENTIFICACIÓN DE ACCESORIOS/ IDENTIFICATION OF ACCESSORIES



–NOTAS: A separação dos acessórios antes de iniciar a montagem facilitará a mesma. Os parafusos e cavilhas estão na escala real. Em caso de dúvida na identificação, coloque o acessório sobre a imagem.

–NOTAS:La separación de los accesorios antes de comenzar el armado facilitará el mismo. Los tornillos y taquetes son en escala real. En caso de dudas sobre la identificación, coloque el accesorio en la imagen.

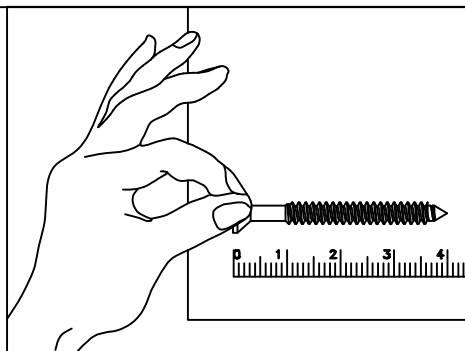
–NOTES:The separation of the accessories before you start the assembly will facilitate the same. The screws and dowels are in real scale. In case of doubts about the identification, place the accessory on the image

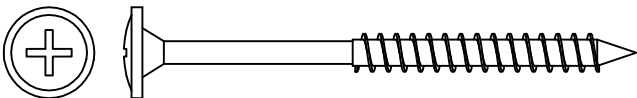
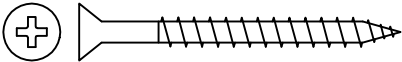
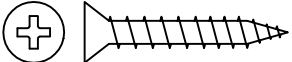

## Ferragem / Herrajes / Hardware

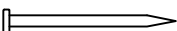
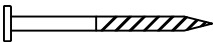
	Código/ Código/ Code	Descrição / Descripción / Description	Quan./ Cant./ Amou.
PF9	50311	 Parafuso flangeado/ Tornillo de cabeza flangead/ Flanged head screw 5,0x65mm	4
PC8	226	 Parafuso chato/ Tornillo de cabeza plana/ Flat head screw 4x40mm	11
PC4	54117	 Parafuso chato/ Tornillo de cabeza plana/ Flat head screw 3,5x25mm	6
PC3	4214	 Parafuso/ Tornillo/ Screw 3,5X14	44
C1	1802	 Cavilha/ Pin/ Wooden Dowel 6x30mm	16
PR1	107	 Prego/ Clavo/ Nail 10x10mm	21
PR2	108	 Prego/ Clavo/ Nail 12x12mm	4

## Prezado Montador:

– Antes de iniciar a montagem verifique as condições do ambiente de montagem;  
– Confira todas as peças das embalagens com a lista de peças contida neste manual;  
– Separe os acessórios, confira as medidas dos parafusos com a escala;  
– Siga todas as orientações deste manual de montagem para ter o direito à garantia do produto;  
– Descarte as embalagens de forma correta, destinando o plástico e o papel para reciclagem;

## Estimado Montador:

– Antes de iniciar a montagem verifique as condições do ambiente de montagem;  
– Confira todas as peças das embalagens com a lista de peças contida neste manual;  
– Separe os acessórios, confira as medidas dos parafusos com a escala;  
– Siga todas las orientaciones deste manual de montaje para ter o direito à garantia do produto;  
– Descarte como embalagens de forma correta, destinando o plástico e o papel para reciclagem;









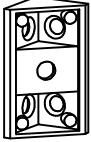

## Dear Fitter:

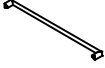
– Before starting montagem check as conditions of the assembly environment;  
– Check out all the packaging com a list of fish contained in this manual;  
– Separate the accessories, check the measures two parafuses com to scale;  
– Follow all the guidelines of this manual montagem for ter or direct to guarantee of the product;  
– Discard the packages correctly, allocating either plastic or paper for recycling;

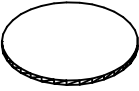

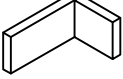
## M623

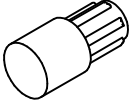
## IDENTIFICAÇÃO DOS ACESSÓRIOS/ IDENTIFICACIÓN DE ACCESORIOS/ IDENTIFICATION OF ACCESSORIES

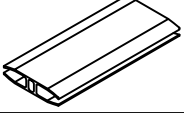
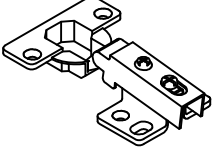
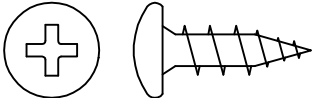
Ferragem / Herrajes / Hardware			
	Código/ Código/ Code	Descrição / Descripción / Description	Quan./ Cant./ Amou.
CG	899	 Cantoneira/Cantón /Angle bracket	4
CB	41	 Cola branca em bispaga/Cola blanca/White glue	1
LM	85	 "L" de metal/Cantón "L" de metal/Metal angle bracket "L"	8
PX	63108	 Puxador/Asar/Handle	2
SD	1901	 Sapata deslizador preta/Zapata negra/Shoe black	4
EM	58	 Etiqueta marca/Tag label "Kappesberg"	1
TP2	NGFE/NGVE=63102 (Nogueira)	 Tapa furo/Tapa del agujero/Screw cap cover 13mm	10
S10	17024	 Suporte aéreo/Suporte de seguridad/Safety bracket	2
CS	6959	 Capa para suporte /Cubierta de soporte/Support cover	2
BC	529	 Bucha invasa/Adapter sleeve/ Manga del adaptador	4
S2	118	 Suporte para prateleira/Suporte de estante/Shelf support 6x8mm	6
GS	40534	 Silicóne/Silicona/ Selecone	4
PH	NGFE/NGVE=26076 (Carvalle)	 Perfil H/Perfil de acabado/Finishing profile	1
D011	51322	 Dobradiça reta calço fixo e amortecedor/Bisagra/ Hinge 35mm	4
	61971	 Parafuso da dobradiça/ Tornillo del bisagra/Hinge Screw 4,0x14	24



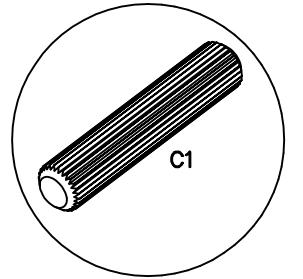
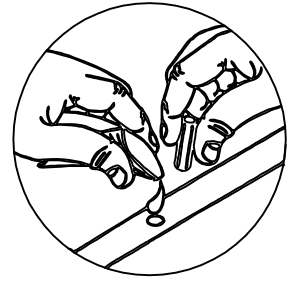
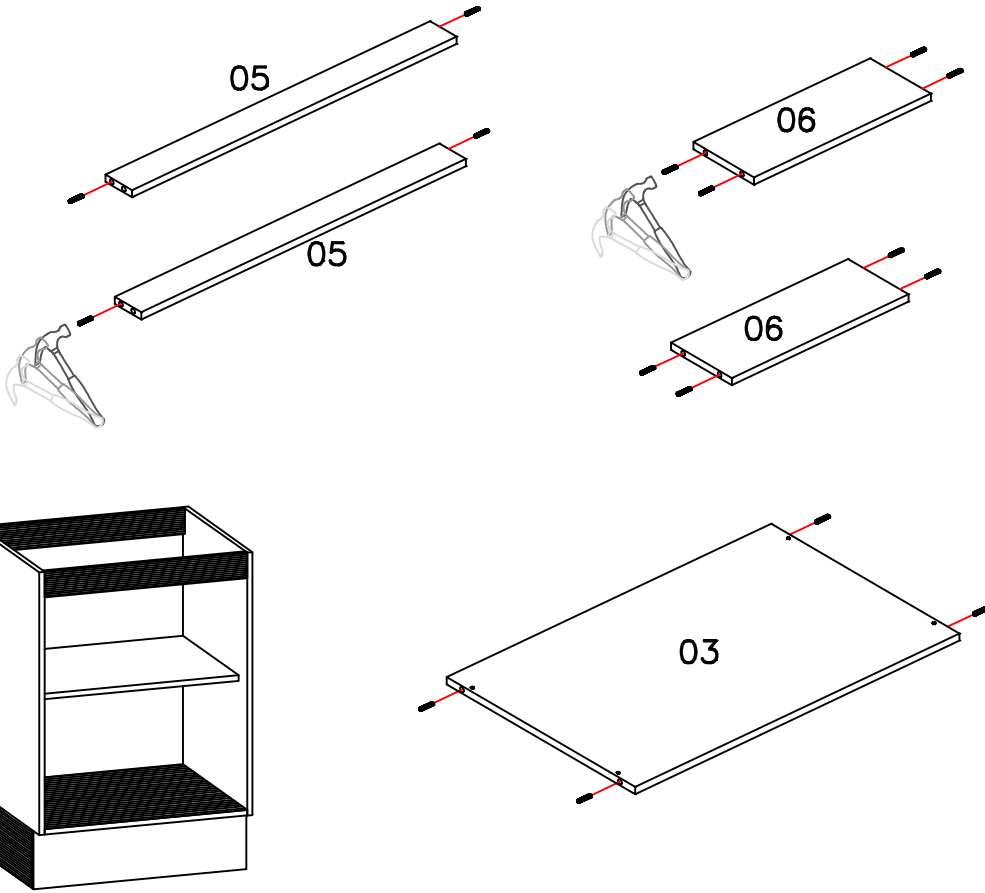

**01** PASSO/ PASO/ STEP

C1		16
----	---	----

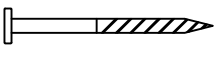

**02** PASSO/ PASO/ STEP

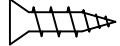
PR2		4
SD		4
CG		4
PC3		8

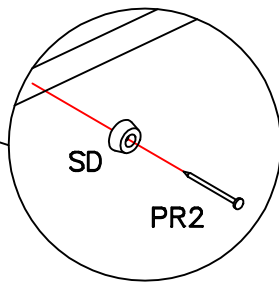
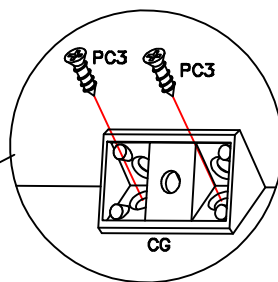
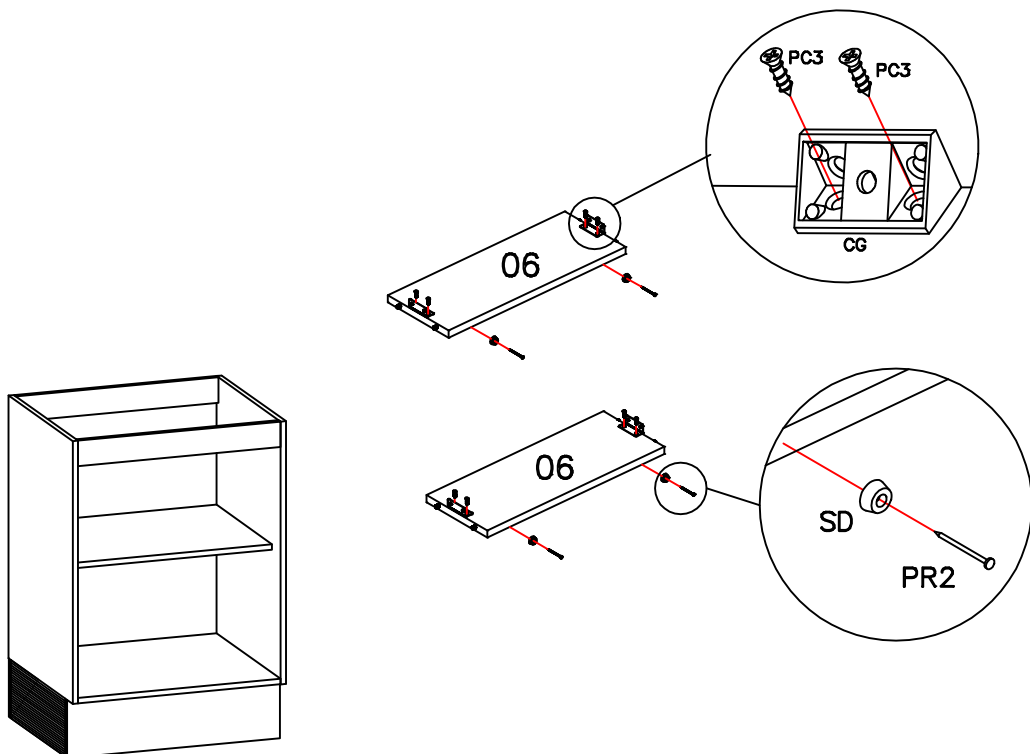

# M623

## 03 PASSO/ PASO/ STEP

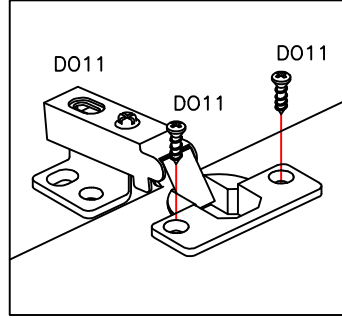

D011		4
D011		8



-ATENÇÃO PARA O ALINHAMENTO DAS DOBRADIÇAS  
 -ATENCIÓN PARA ALINEAR LAS BISAGRAS  
 -ATTENTION TO THE ALIGNMENT OF THE HINGES

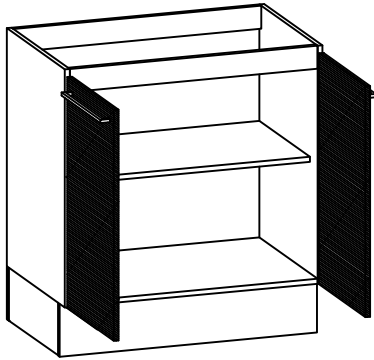
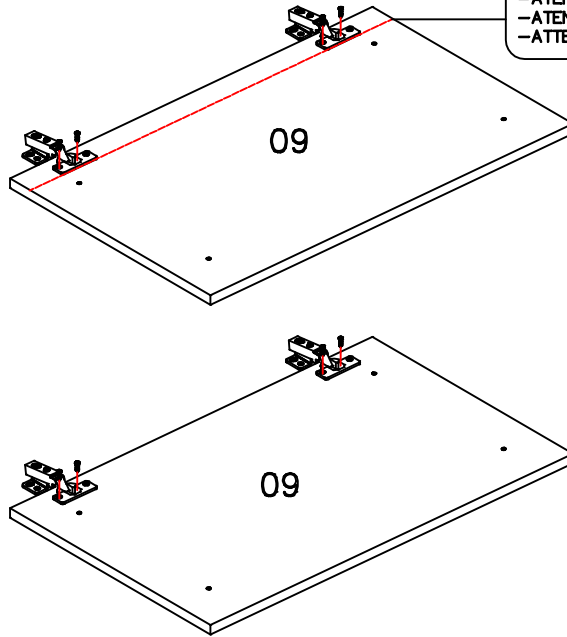

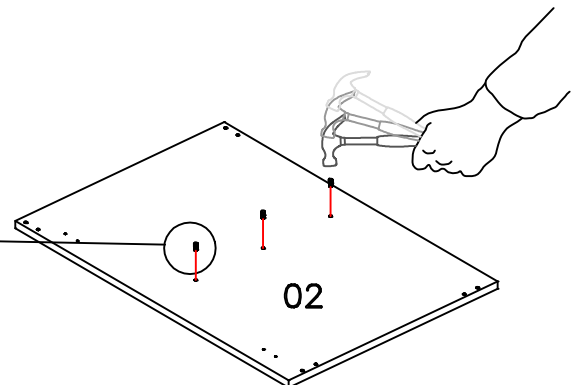
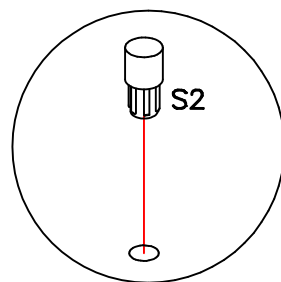
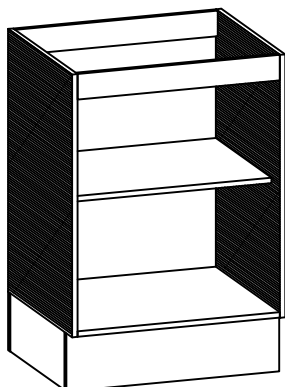
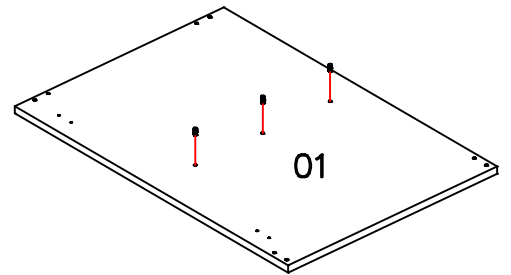

## 04 PASSO/ PASO/ STEP

S2		6
----	--	---



# M623

## 05 PASSO/ PASO/ STEP

PC8		8
TP2		8

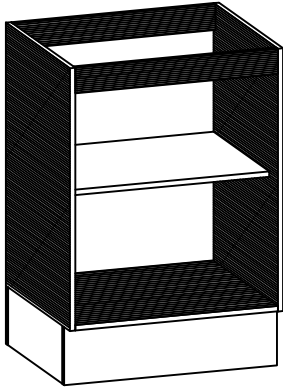
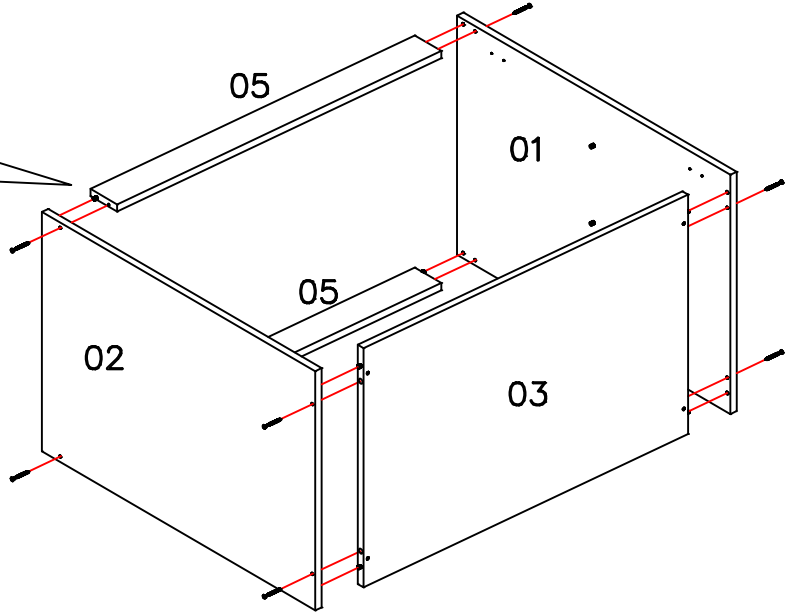
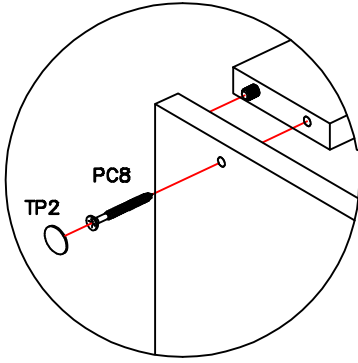

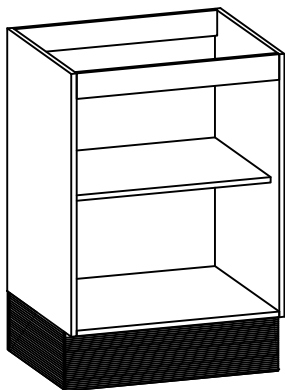
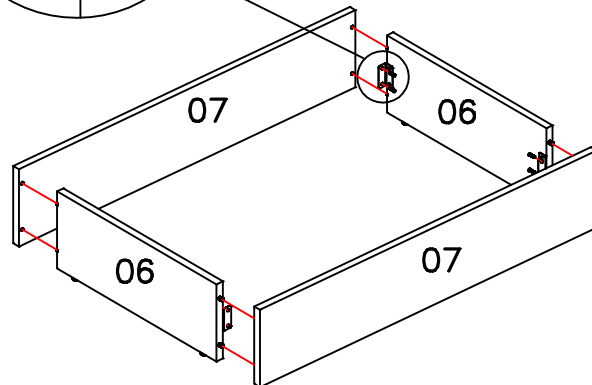
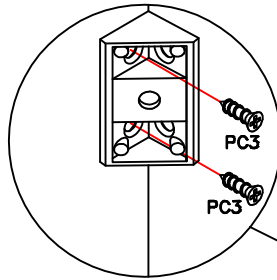

## 06 PASSO/ PASO/ STEP

PC3		8
-----	---	---



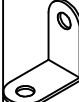

# M623

## 07 PASSO/ PASO/ STEP

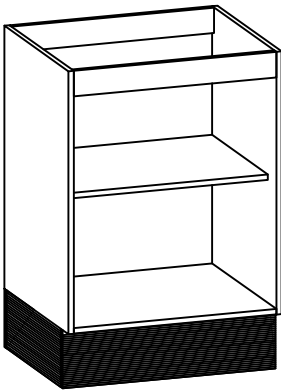
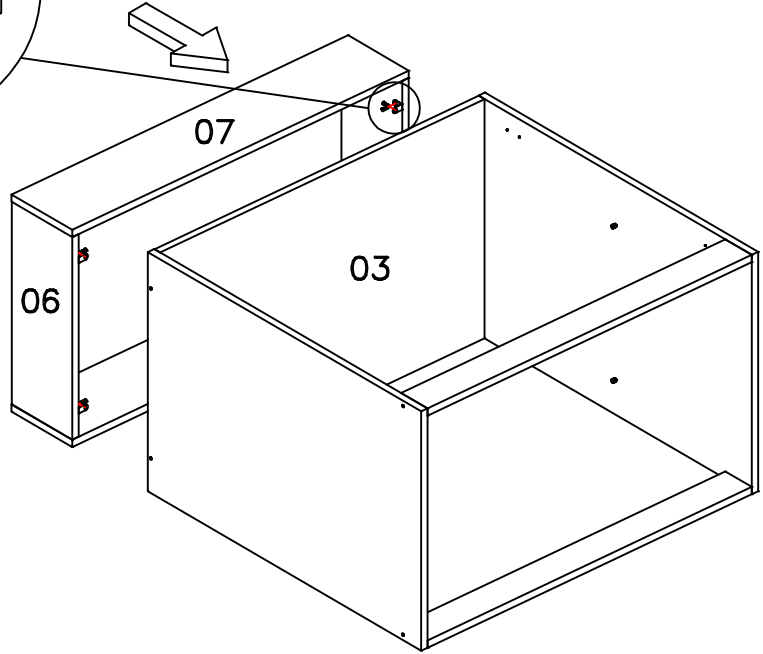
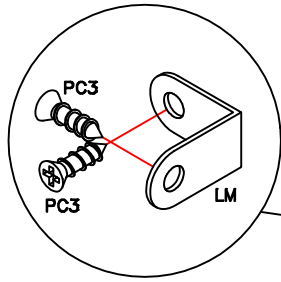
LM		4
PC3		8

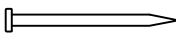

## 08 PASSO/ PASO/ STEP



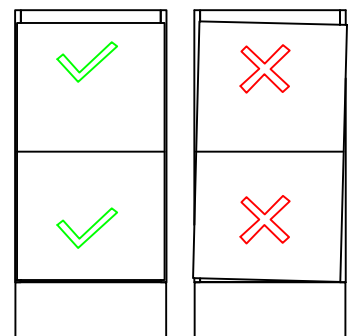
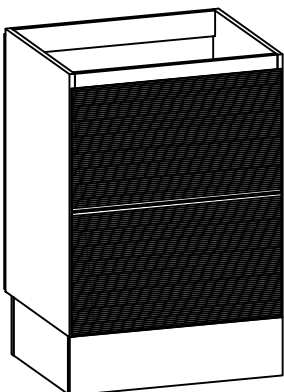
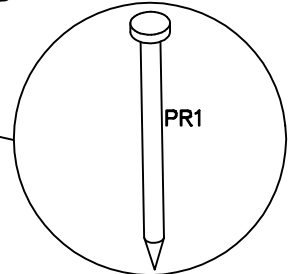
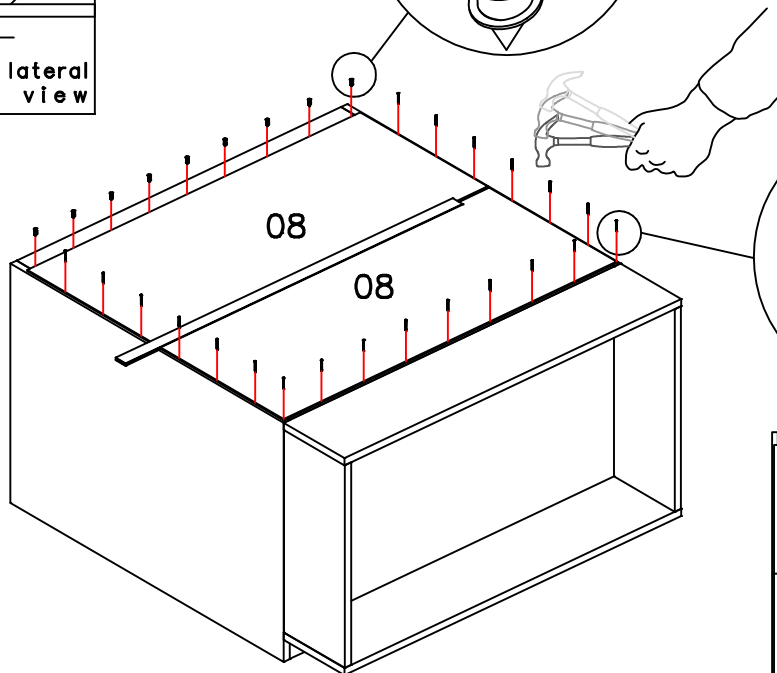
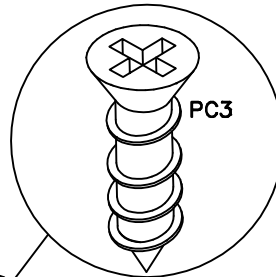
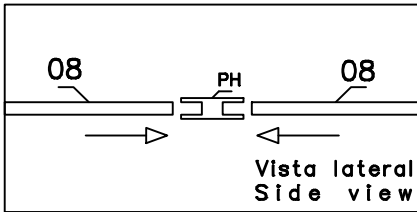

PR1		21
PC3		8
PH		1



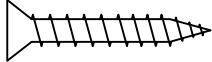

## M623

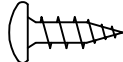
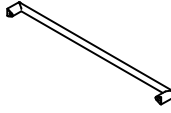
09 PASSO/ PASO/ STEP

PC4			4
D011			16
PX			2
GS			4

**NOTA:** Utilize o furo oblongo para posicionar a altura da dobradiça. E por fim quando a porta estiver posicionada de maneira correta utilize o furo circular para garantir que a mesma não se desloque.

**NOTAS:** Utilice o furo oblongo para posicionar a altura da dobradiça. E por fim quando a porta estiver posicionada de maneira correta utiliza o furo circular para garantir que a mesma não se desloque.

**NOTE:** Use the oblong edge to position at the height of the dobradiça. And for this reason, when the estiver holder is positioned in a correct way, use a circular hole to ensure that it does not loosen at the same time.

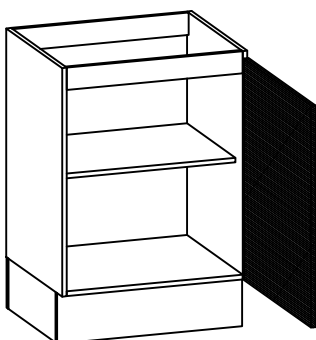
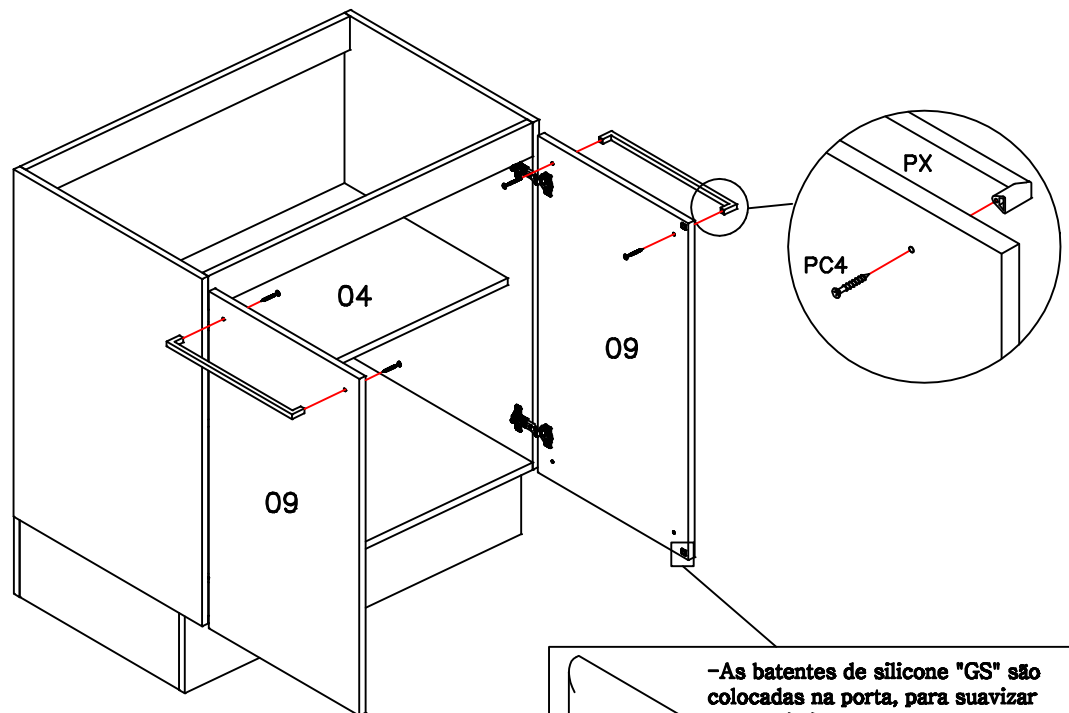
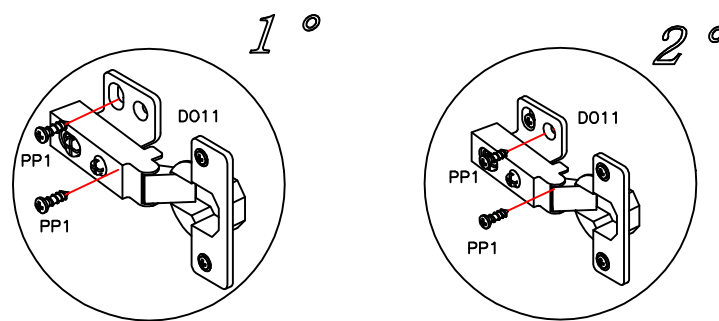

GS

-As batentes de silicone "GS" são colocadas na porta, para suavizar eventuais impactos.  
 -Los topes de silicona "GS" se colocan en la puerta, para suavizar los impactos.  
 -The silicone stops "GS" are placed on the door, to soften any impacts.



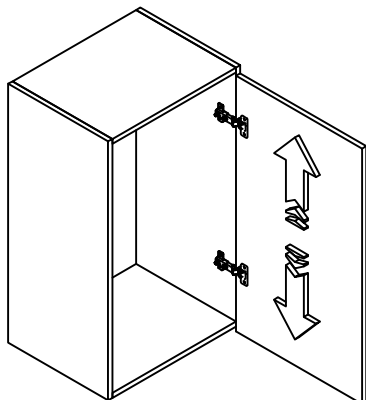
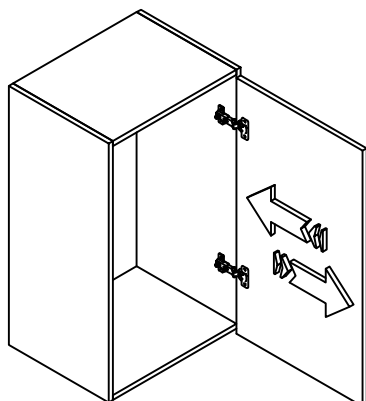
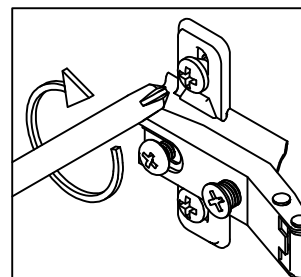
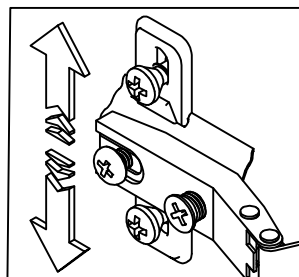
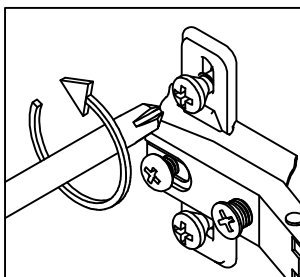
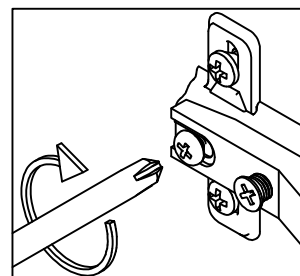
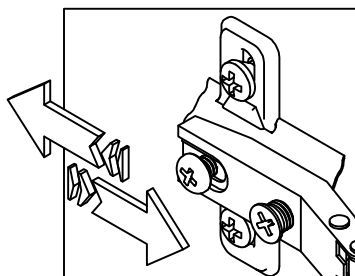
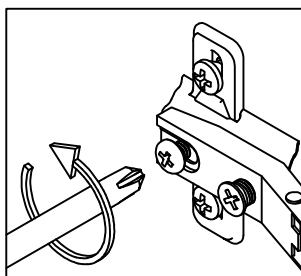
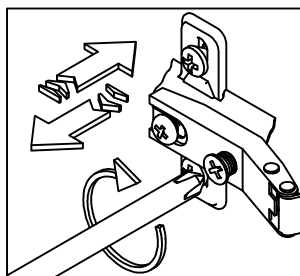
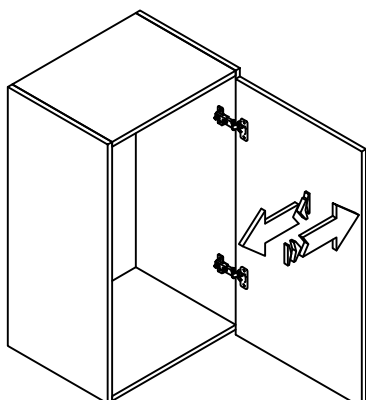

## M623

**10 AJUSTE DE PORTAS/ AJUSTE DE PUERTA/ DOORS ADJUSTMENT****REGULAGEM VERTICAL/ AJUSTE VERTICAL/ VERTICAL ADJUSTMENT****REGULAGEM PROFUNDIDADE/ AJUSTE PROFUNDIDAD/ DEPTH ADJUSTMENT****REGULAGEM HORIZONTAL/ AJUSTE HORIZONTAL/ HORIZONTAL ADJUSTMENT**

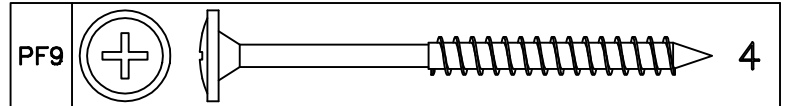
## M623

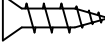
11 PASSO/ PASO/ STEP

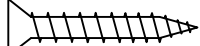
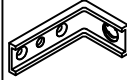
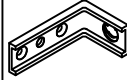
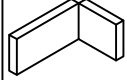
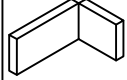
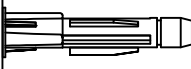
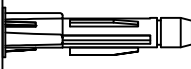

PC3			4
PC4			2
S10			2
CS			2
BC			4
TP2			2

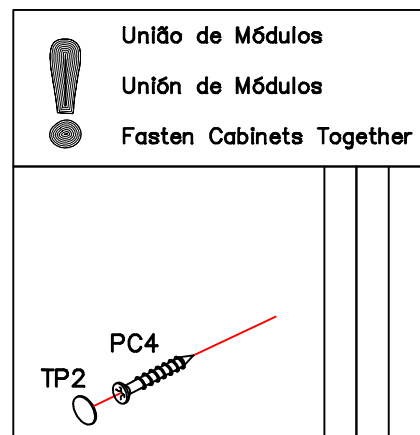
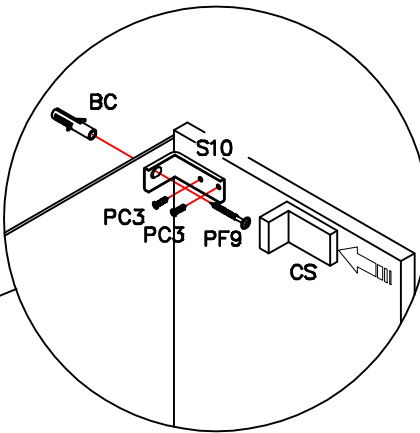
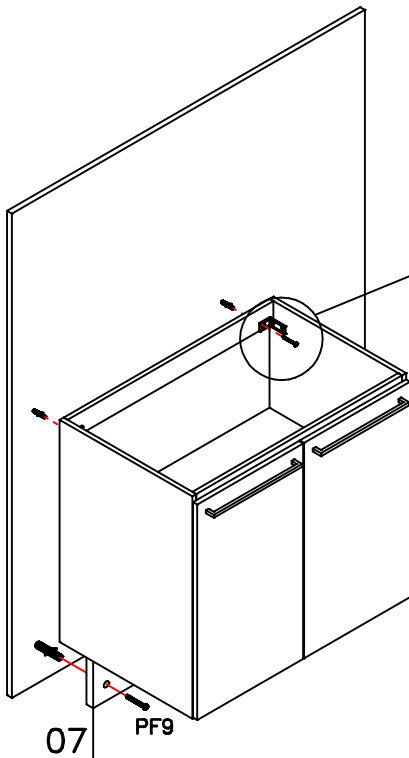

União de Módulos

Unión de Módulos

Fasten Cabinets Together

Para montar a cozinha suspensa:

- Utilize o rodapé frontal "07" que acompanha o móvel como apoio para sua fixação na parede, utilizando a bucha "BC" e o parafuso "PF9".
- Em cada lateral fixe um suporte aéreo metalizado "S10" com o parafuso "PC3" e na parede com o parafuso "PF9" e com a bucha "BC".
- Coloque uma capa "CS" em cada suporte "S10".

Para montar la cocina suspendida:

- Utilizar el rodapié frontal "07" que viene con el mueble como soporte para fijarlo a la pared, mediante el casquillo "BC" y el tornillo "PF9".
- En cada lado, fijar un soporte aéreo metalizado "S10" con el tornillo "PC3" y en la pared con el tornillo "PF9" y con el casquillo "BC".
- Colocar una funda "CS" en cada soporte "S10".

To assemble the suspended kitchen:

- Use the front skirting board "07" that comes with the furniture as a support for fixing it on the wall, using the "BC" bushing and the "PF9" screw.
- On each side, fix a metalized aerial support "S10" with the screw "PC3" and on the wall with the screw "PF9" and the bushing "BC".
- Place a cover "CS" on each support "S10".

## M623

**12** PASSO/ PASO/ STEP

PC8

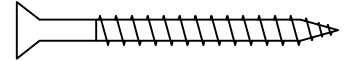

3

Produto segue com manual de instalação e todas as ferragens necessárias para sua montagem, e montagem do tampo. Caso não haja a compra do tampo os acessórios que contém no mesmo irão sobrar.

Producto a continuación con manual de instalación y todos los herrajes necesarios para su montaje, y montaje de la encimera. Si no hay compra de la tapa, los accesorios que contiene se mantendrán.

Product follows with installation manual and all the necessary hardware for its assembly, and assembly of the worktop. If there is no purchase of the top, the accessories it contains will remain.

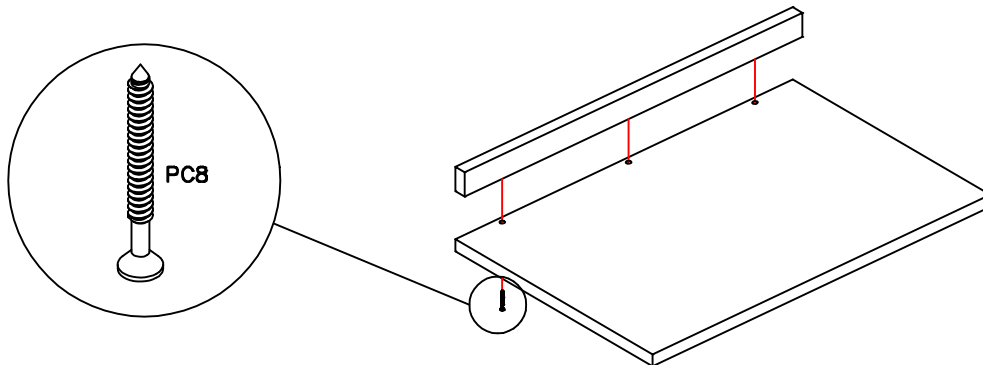
**13** PASSO/ PASO/ STEP

LM		4
PC3		8

