

Balcão Canto Obliquo 01 Porta Connect | Balcón Esquina Obliquo 1 Puerta Connect | Corner Oblique 1 Door Connect

- ☐ C67-35 - Duna/Cristal
☐ C67-42 - Fendi

Requisitos para montagem
Requisitos para la montaje
Assembly Requirements

Imagens meramente ilustrativas,
não acompanha o produto.
Imágenes ilustrativas, no incluidas
con el producto.
Illustrative images, not included
with the product.

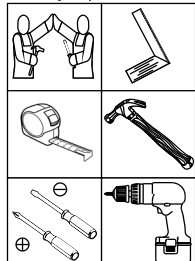
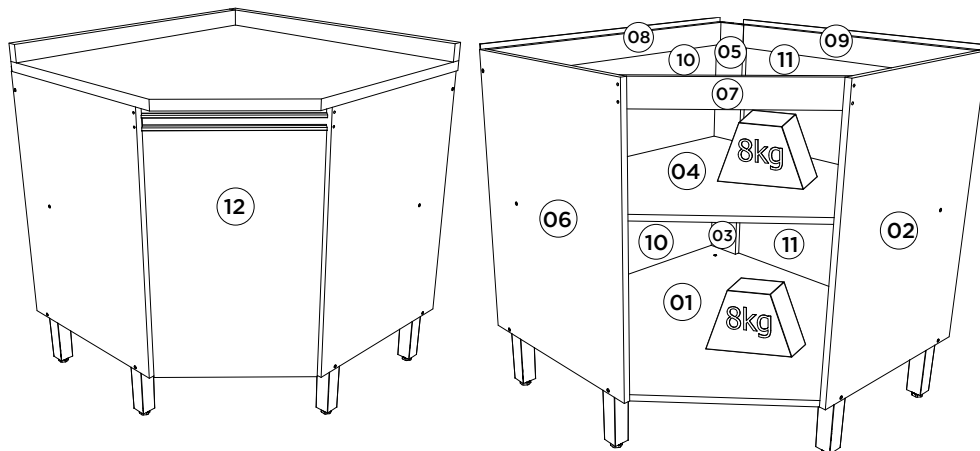

Pesos máximos recomendados com carga distribuída
Peso máximo recomendado con la carga distribuída
Recommended maximum weights with evenly distributed.

Lista de Peças | Lista de piezas | List of parts

Item	Caixa Caja Box	Qtd Ctd Qty	Descrição Descripción Description	Medidas (mm) Dimensions (mm) Size (measurements) (mm)
01	1/1	01	Base Base Base	770x770x15
02	1/1	01	Lateral Direita Lateral Derecha Right Side	675x490x15
03=05	1/1	01	Travessa sustentação apoyo travesaño support beam	322x100x15
04	1/1	01	Prateleira Estante Shelf	770x770x15
05=03	1/1	01	Travessa sustentação apoyo travesaño support beam	322x100x15
06	1/1	01	Lateral Esquerda Lateral Izquierda Right Left	675x490x15
07	1/1	01	Travessa frontal chanfrada Travesaño frontal biselado Travessa Front Bevel	427x60x15
08	1/1	01	Travessa traseira maior Travesaño trasero más grande Largest rear crossbar	755x60x15
09	1/1	01	Travessa traseira menor Travesaño trasero pequeño Minor backslash	670x60x15
10	1/1	02	Fundo maior Fondo más grande Larger fund	779x341x3
11	1/1	02	Fundo menor Fondo inferior Lower fund	697x341x3
12	1/1	01	Porta Puerta Door	625x396x15

Ferragens | Herrajes | Hardware

A	05.	B	03.	C	06.	D	04.	E	09.	F	04.	G	24.	H	25.	I	04.	J	04.	
	Parafuso 7,0x40mm CHT. Tornillo 7,0x40mm CHT. Screw 7,0x40mm CHT.		Parafuso 5,0x50mm FLA. Tornillo 5,0x50mm FLA. Screw 5,0x50mm FLA.		Parafuso 4,5x50mm CHT. Tornillo 4,5x50mm CHT. Screw 4,5x50mm CHT.		Parafuso União 30mm Tornillo Unión 30mm Union Screw 30mm		Parafuso 3,5x40mm CHT. Tornillo 3,5x40mm CHT. Screw 3,5x40mm CHT.		Parafuso 4,0x25mm CHT. Tornillo 4,0x25mm CHT. Screw 4,0x25mm CHT.		Parafuso 3,5x14mm FLA. Tornillo 3,5x14mm FLA. Screw 3,5x14mm FLA.		Parafuso 3,5x12mm CHT. Tornillo 3,5x12mm CHT. Screw 3,5x12mm CHT.		Parafuso minifix Tornillo minifix Minifix bolt		Tambor minifix Tambor minifix Minifix drum	
K	14.	L	01.	M	52.	N	13.	O	05.	P	02.	Q	02.	R	05.	S	01.	T	01x	
	Cavilha 8x25mm Cinta 8x25mm Dowel 8x25mm		Suporte metal Soporte metálico Metal support		Prego 10x10mm Clavo 10x10mm Nail 10x10mm		Fixador de fundos Fijador de fondos Bottom fixer		Cantoneira plástica Cantoneira plástica Plastic angle brackets		Calço metal p Dobradilha 45° Calzo metálico p Dobradilla 45° Metal chock p 45° hinge		Dobradilha metal 35mm 45° Bisagra de metal 35mm 45° Metal hinge 35mm 45°		Pé 145mm x 42mm Pie 145mm x 42mm Foot 145mm x 42mm		Puxador MOV 396mm Tirador MOV 396mm MOV 396mm Handle		Sachê de cola Bolsa de pegamento Glue bag	
U	02.	V	03.	W	03.	X	03.	Y	01.	Z	16.	AA	05.	AB	02.					
	Batente PVC para Porta Parada de PVC para Puerta PVC Door Stop		Bucha plástica 8mm Bucha de plástico 8mm 8mm plastic bushing		Suporte de fixação Soporte de fijación Mounting bracket		Proteção para cantoneira Ángulo de protección Protection angle		Etiqueta resinada Henn Etiqueta resinada Henn Henn resin label		Adesivo tapa parafuso 10mm Adhesivo tapón de tornillo 10mm Bolt cover adhesive 10mm		Adesivo tapa parafuso 17mm Adhesivo tapón de tornillo 17 mm Bolt cover adhesive 17mm		Giz de correção Tiza de corrección Chalk of correction					

O parafuso (D) deve ser usada somente quando este módulo for acoplado a outro módulo componível Henn.

El tornillo (D) se debe utilizar sólo cuando el módulo está conectado a otro módulo componible Henn.

The screw (D) should be used only when this module is attached to another Henn modular module.

RECOMENDAÇÃO

Para fixar o móvel na parede usar o suporte de fixação (W), o parafuso 3,5x14mm FLA (G), a Bucha 8mm (V) e o parafuso 5,0x50mm FLA (B).

RECOMENDACIÓN

Para conectar el móvil a la pared con el soporte (W), tornillo 3,5 x14mm FLA (G), el casquillo de 8 mm (V) y el 5,0 x50mm tornillo FLA (B).

RECOMMENDATION

To fix the furniture to the wall use the fixing bracket (W), the 3.5x14mm FLA (G) screw, the 8mm bushing (V) and the 5.0x50mm FLA (B) screw.

IMPORTANTE

Na Referência C67-35 vai ter 1 parafuso 3,5x40 CHT e 1 Adesivo 10mm Trama mais, púes estes poderão ser utilizados quando montado o C953- Rodapé para Balcão Canto Obliquo fechamento lateral e C964- Rodapé para Balcão Canto Obliquo Completo.

IMPORTANTE

En la Referencia C67-35 va a tener 1 tornillo 3,5x40 CHT y 1 Adhesivo 10mm Trama más, púes estos podrán ser utilizados cuando montado el C953- Rodapé para Balcão Canto Obliquo cierre lateral y C964- Rodapé para Balcão Canto Obliquo Completo.

IMPORTANTE

In Reference C67-35 will have 1 screw 3.5x40 CHT and 1 adhesive 10mm Trama more, as these can be used when mounted the C953-Oblique Corner Corner Skirting Side Closure and C964- Oblique Corner Complete Skirting Board.

1

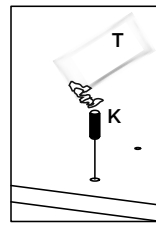
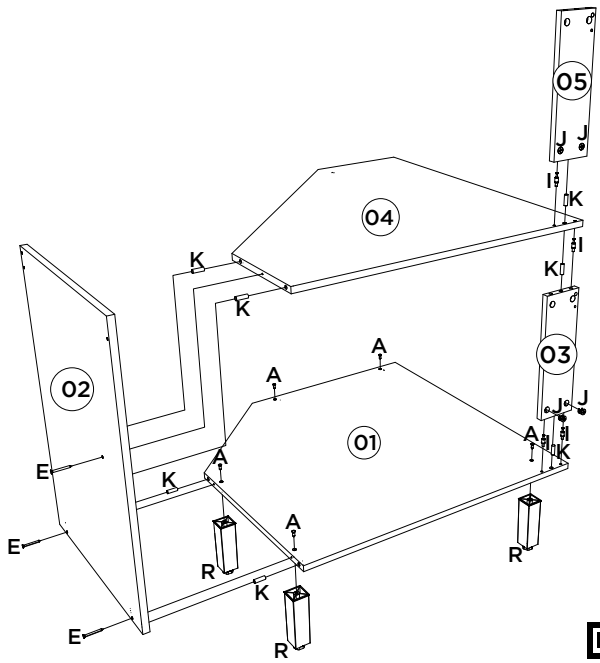

Utilizar o sachê de cola (T) em todas as cavilhas (K) do produto.

Con el pegamento sobre (T) en todos los pernos (K) producto.

Use the glue sachet (T) on all the pegs (K) of the product.

Vídeo: Dicas para fixar o Minifix

Vídeo: Consejos para arreglar Minifix

Vídeo: Tips for Fixing Minifix



2

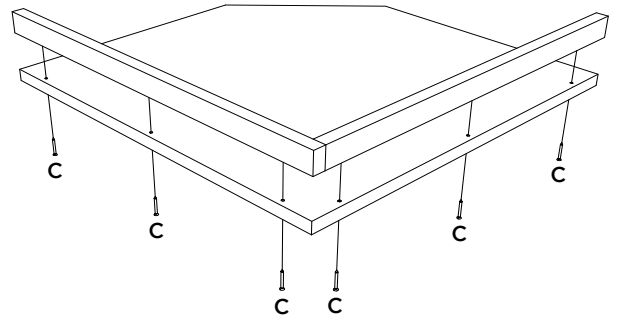

Esse tempo é opcional e é vendido separadamente (C907-33).

Esta vez es opcional y se vende por separado (C907-33).

This top is optional and is sold separately (C907-33).

3

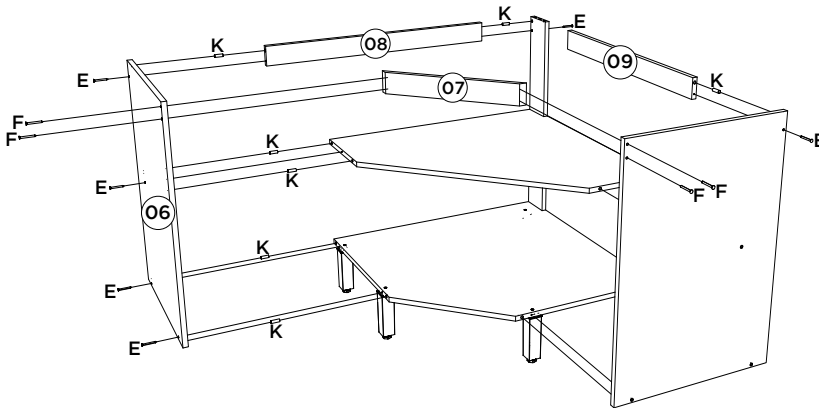

4

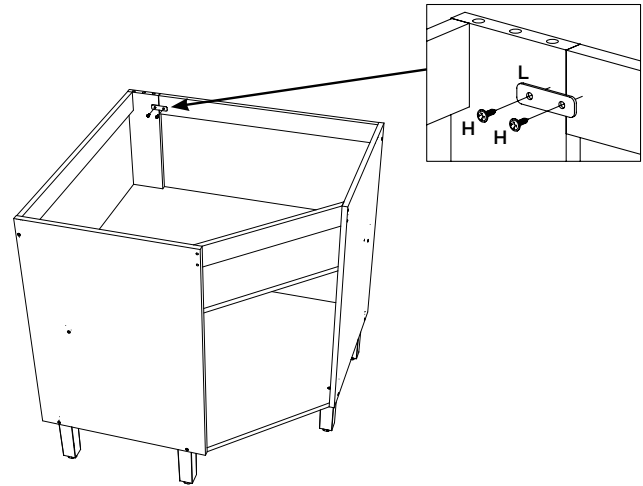

5

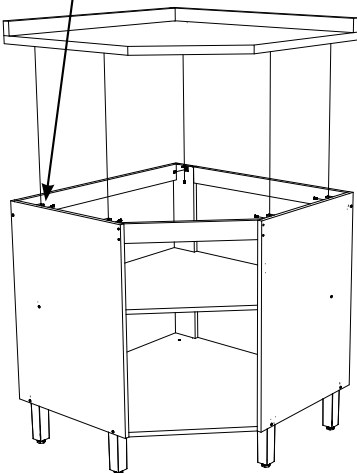
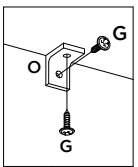

6

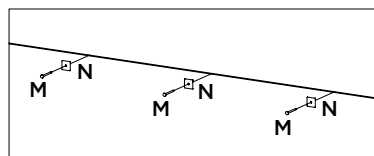
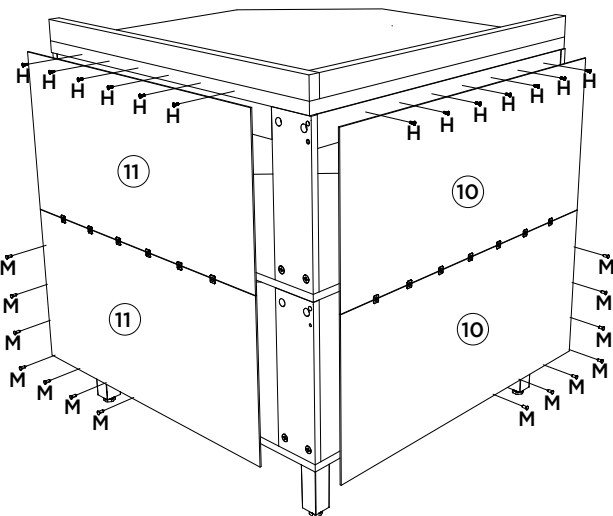

7

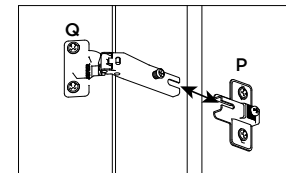
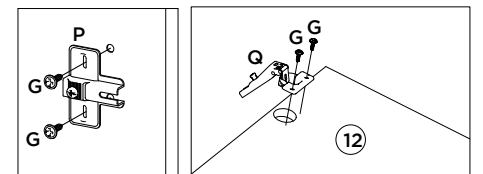
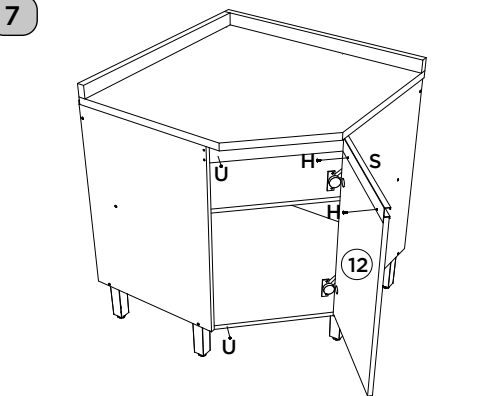

Vídeo: Instalar e regular Dobradiças

Vídeo: Instale y ajuste las bisagras

Vídeo: Install and adjust hinges

2