

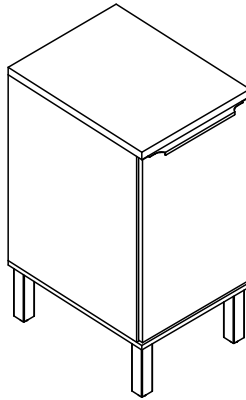

Rodovia SC-492 - Km 10 - B. Industrial
89905-000 - Bandeirante - SC
Fone: (49) 3622-4549
e-mail: mxmoveis@mxmoveis.com.br



Ref. BVE02

Balcão 400
Mueble base 400
Cozinha/Cocina
Verace

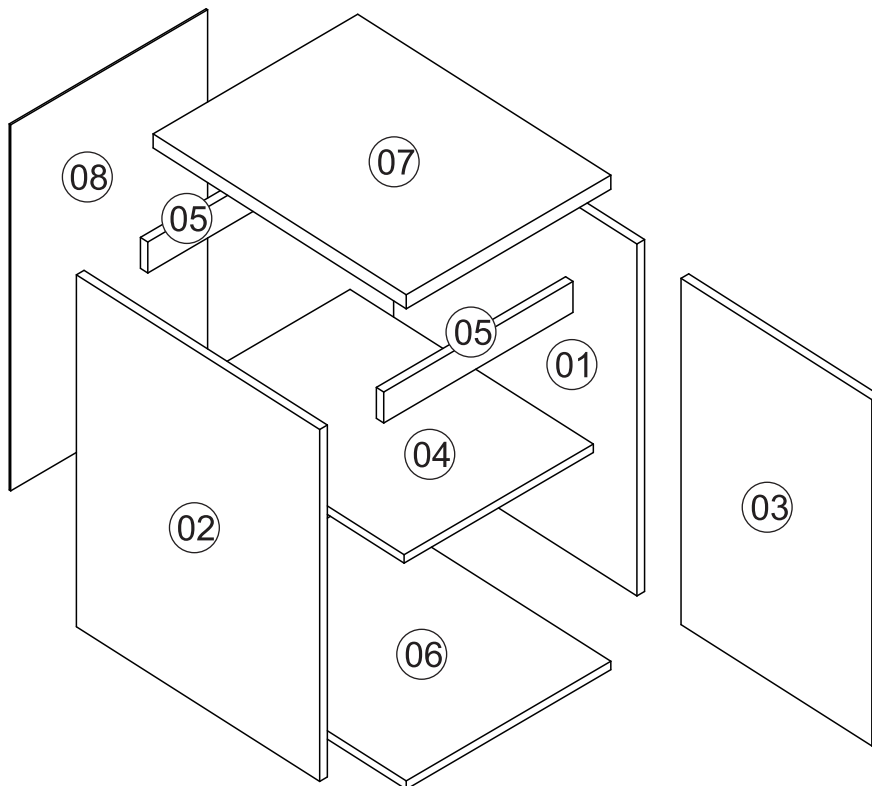



Nº	CÓDIGO ASSISTÊNCIA	NOME DA PEÇA/DESCRIPCIÓN PIEZAS	MEDIDAS (mm)	QTD.	CÓDIGO DAS PEÇAS/CÓDIGO PIEZAS			
					HAVANA	TAUPE	TAUPE	OFF WHITE
01	BVE02.17.00	Lateral externa direita/Lateral derecha	625x496x15	01	48851		53485	
02	BVE02.18.00	Lateral externa esquerda/Lateral izquierda	625x496x15	01	47852		53486	
03	BVE02.25.00	Porta balcão/Puerta	615x388x15	01		47853		53487
04	BVE02.27.00	Prateleira interna/Repisa	370x400x15	01	47501		47501	
05	BVE02.28.00	Ripa balcão/Travesaño	370x55x15	02	167678		167680	
06	BVE02.01.00	Base inferior/Base inferior	400x516x15	01	59182		59184	
07	BVE02.33.00	Tampo balcão/Tapa	400x516x25	01	176447		176689	
08	BVE02.13.00	Forno/Revés	615x390x2.5	01	47503		47503	

Ferragens/Herrajes

A 04x

 Cavilha Ø6,0x30mm
 Cód. 873

B 08x

 Parafuso 4,0x50mm Cht.
 Cód. 12537

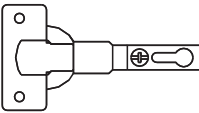
C 13x

 Parafuso 3,0x12mm Cht.
 Cód. 11413

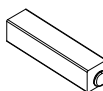
D 02x

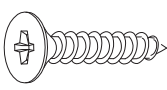
 Dobradiça 26 mm
 Cód. 10269

E 08x

 Parafuso 4,0x12mm Cht.
 Cód. 7604

F 04x

 Pé plástico
 Cód. 1973

G 04x

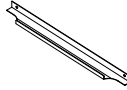
 Parafuso 3,5x25mm Cht.
 Cód. 692

H 04x

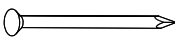
 Cantoneira metálica
 Cód. 7168

I 01x

 Puxador / Manija
 Cód. 1816

J 16x

 Prego 8x8
 Cód. 822

K 04x

 Parafuso 5,0x50mm Cht.
 Cód. 1979

L 04x

 Parafuso 3,5x40mm Cht.
 Cód. 691

D 02x



 Calço Dobradiça
 Cód. 12539

M 01x

 Bisnaga cola
 Cód. 8255

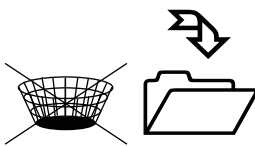
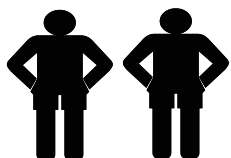

Medidas em mm

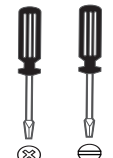
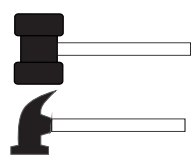
				
---	---	---	--	---

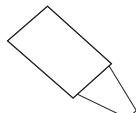
 Giz para madeira

Produto para ser aplicado em caso de riscos na superfície

Pré-Montagem/Preparación Piezas

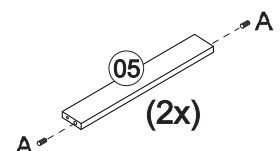
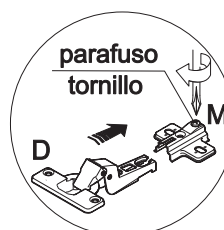
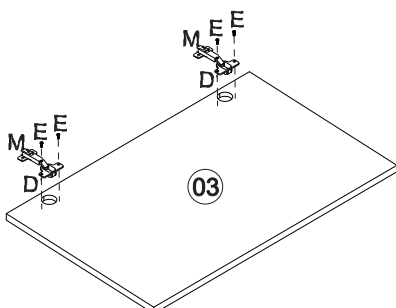

Montagem/Montaje

01

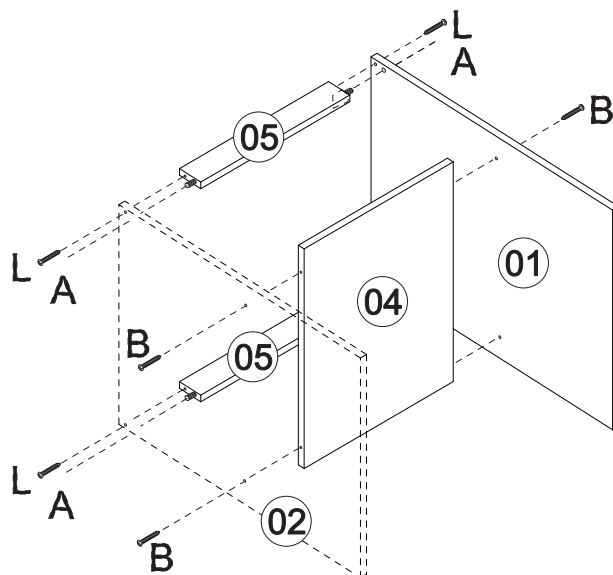

02

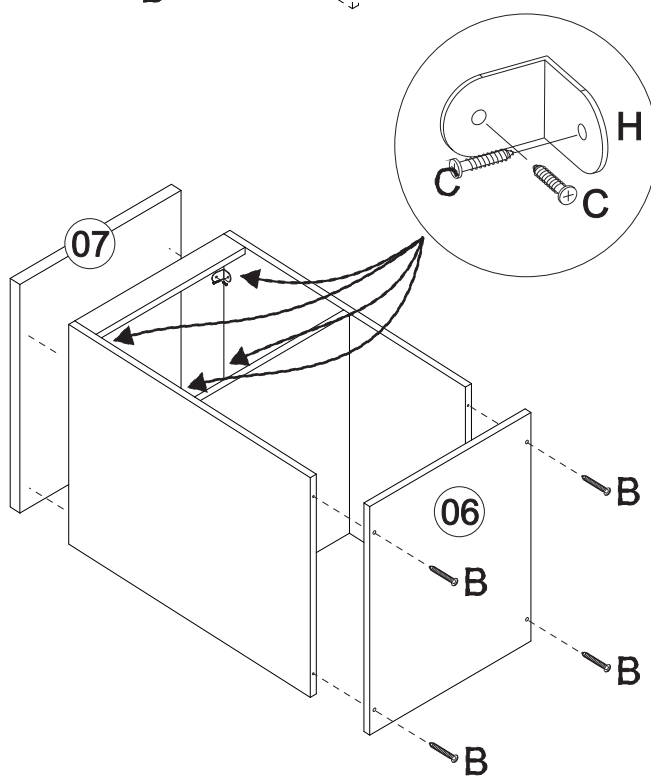

03

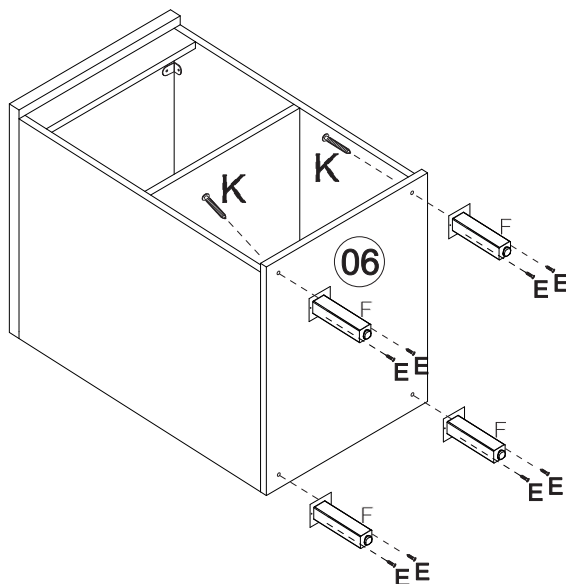

Montagem/Montaje

04

ATENÇÃO!!!

É importante colocar o móvel no esquadro antes de fixar as costas. Para isto utilize uma trena observando que a medida 1 deve ser igual à medida 2.

ATENCIÓN!!!

Es importante hacer una escuadra perfecta entre el fondo y la estructura del mueble. Observe que la medida 1 debe ser la misma que la medida 2.

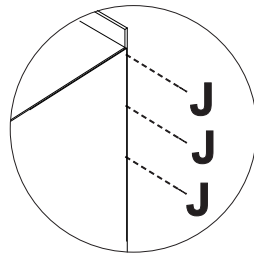
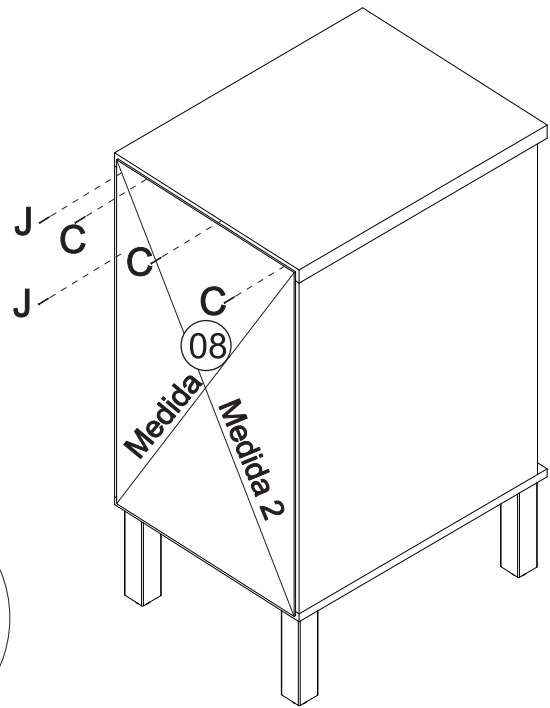

*Colocar um prego (J) a cada 100mm.

05

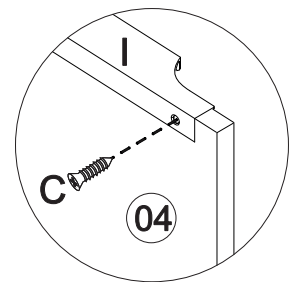
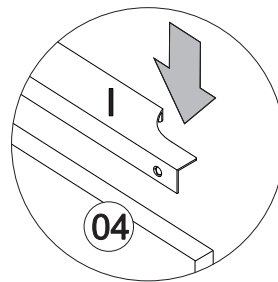
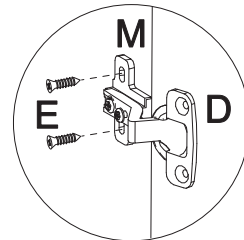
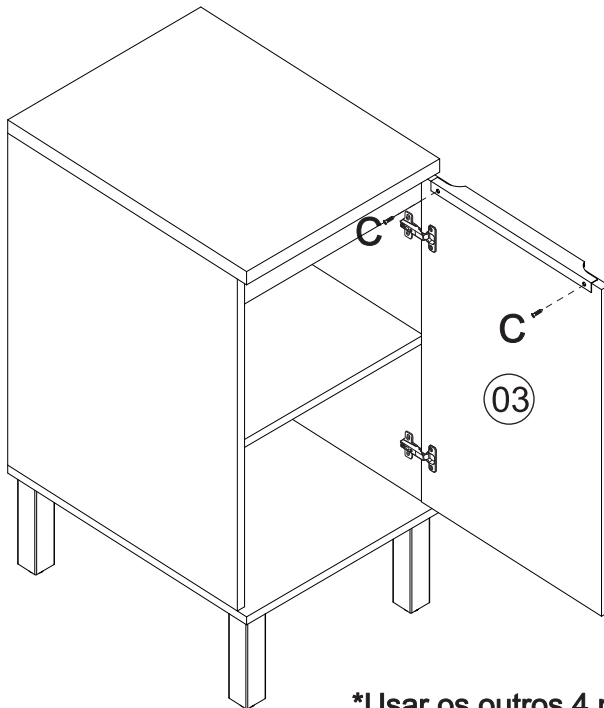

*Usar os outros 4 parafusos (G) para unir este módulo a outro.
Usar los otros tornillos (G) para unirse este modulo a otro.

Limpeza/Limpieza

- ☞ Use um pano levemente umedecido com água, seguido de pano seco.
- ☞ Use solamente un paño húmedo con agua y después un paño seco.
- ☞ Nunca utilize produtos químicos ou abrasivos.
- ☞ No utilice productos quimicos o abrasivos.