



**MANUAL DE MONTAGEM  
ASSEMBLY INSTRUCTIONS  
INSTRUCCIONES DE MONTAJE**

**COD BR: BS 01A**



# Sumário Summary Resumen

Introdução Introduction Introducción	.....	3
Antes de começar Before starting Antes de comenzar	.....	4
Evite acidentes Avoid accidents Evitar accidentes	.....	4
Dimensões e ferramentas Dimensions and tools Dimensiones y herramientas	.....	5
Identificação das peças Identifying parts Identificación de las piezas	.....	6
Acessórios incluídos na caixa Hardware included in box Accesorios incluidos en la caja	.....	7
Montagem do móvel Furniture assembly Montaje del mueble	.....	8

## Introdução Introduction Introducción

Leia atentamente este manual e siga os passos indicados para que o produto não perca a garantia e também para uma perfeita montagem.

Read this manual and follow the steps in order to keep the guarantee and also for the perfect fit.

Lea este manual y siga los pasos para que el producto no pierda la garantía y también para el ajuste perfecto.

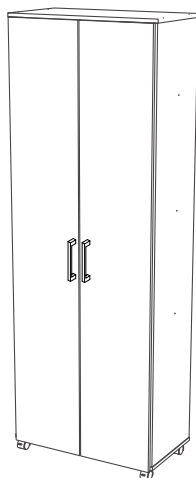

## Antes de começar Before starting Antes de comenzar

Antes de começar a montagem prepare o ambiente, deixando-o completamente limpo e com bom espaço para iniciar o trabalho.

Prepare the room before starting the assembly, leaving it completely clean and the area in good condition to start the work.

Antes de comenzar el montaje preparar el ambiente, dejándolo completamente limpio y con bueno espacio para comenzar el trabajo.

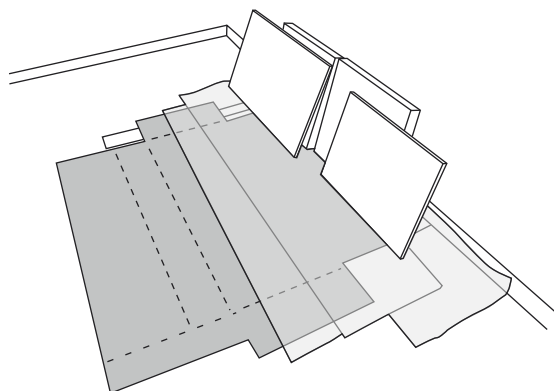

Utilize o papelão da própria embalagem para separar e apoiar as peças retiradas das caixas.

Use the cardboard of the packaging to separate and support the parts removed from the boxes.

Utilice el cartón de la embalaje para separar y apoyar las piezas desmontadas de las cajas.

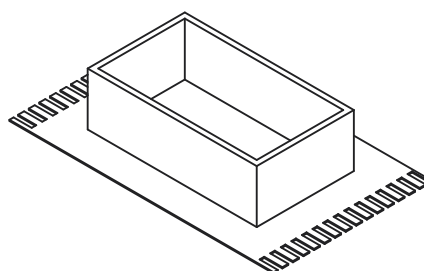

Forre a área de montagem com um cobertor ou tapete. Assim, você evita avarias nas peças durante o processo de montagem.

Cover the assembly area with a blanket or carpet to avoid damaging the parts during the assembly process.

Cubrir la zona de ensamble con una manta o alfombra. De este modo, se evitan daños en las piezas durante el proceso de montaje.



## Evite acidentes Avoid accidents Prevenir accidentes

Solicitamos observar atentamente as orientações de montagem como: fixação do produto na parede, colocação de cola em locais específicos necessários, o peso suportado pelo produto, etc...

We request you to carefully observe the assembly instructions as: fixing the product on the wall, adding glue in needed and specific places, product weight limit, etc.

Pedimos que lea atentamente las instrucciones, principalmente las informaciones de fijación del producto en la pared, colocación de pegamento en local específico y necesario, el peso soportado por el producto etc...

Não escale ou se apoie no móvel.

Do not climb or lean on the furniture.

No se suba ni se apoye en el mueble.

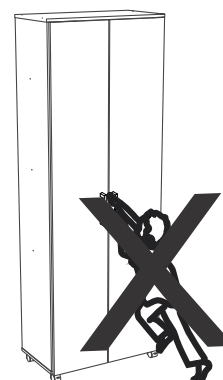

Dimensões e ferramentas  
Dimensions and tools  
Dimensiones y herramientas

Dimensões:

L: 675 A: 1885 P: 368 mm

Dimensions:

W: 26.57 H: 74.21 D: 14.48 inches

Dimensiones:

L: 675 A: 1885 P: 368 mm

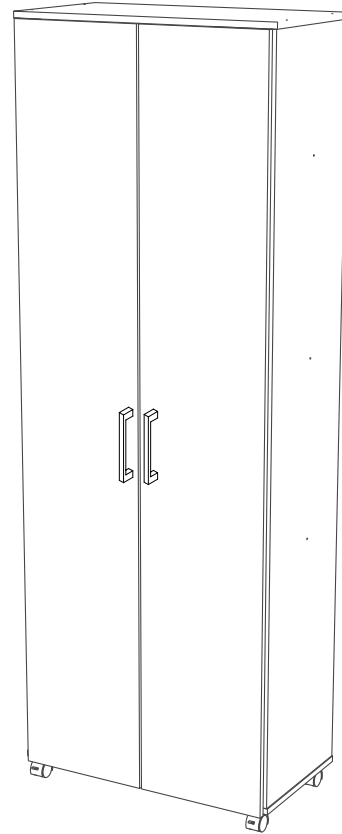

Limpeza  
Cleaning  
Limpieza

Pano levemente umedecido com água, seguido de pano seco, não utilizar produtos químico ou abrasivos.  
Slightly dampened cloth and after a dry cloth, do not use chemicals or abrasives.  
Solamente utilizar un paño húmedo y después un paño seco, no utilice productos químicos o abrasivos.

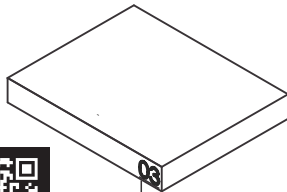

**UTILIZE ALCOOL APENAS PARA REMOVER O NUMERO DAS PEÇAS**  
**USE ALCOHOL ONLY TO REMOVE PART NUMBERS**  
**UTILICE ALCOHOL SOLAMENTE PARA ELIMINAR EL NUMERO DE LAS PIEZAS**

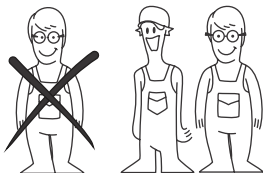

Para facilitar a montagem, utilize uma parafusadeira elétrica.  
To improve assembly, use an electronic screwdriver.  
Para facilitar el armado, utilice un destornillador eléctrico.

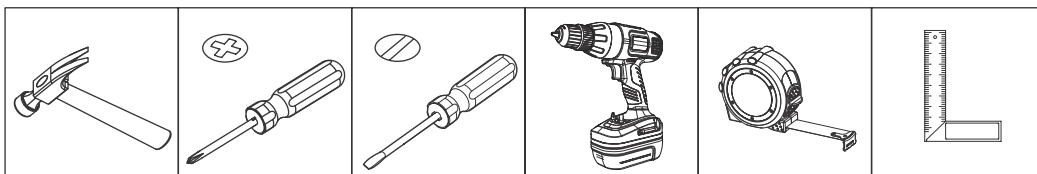

## COD BR: BS 01A

PEÇA	DESCRIÇÃO	QUANT.
001	LATERAL ESQUERDA	1
002	LATERAL DIREITA	1
003	TAMPO / BASE	2
004	PRATELEIRA MENOR	2
005	PRATELEIRA MAIOR	1
006	COSTA	1
007	PORTA	2
008	DIVISÓRIA	1

PART	DESCRIPTION	QTY
001	LEFT SIDE	1
002	RIGHT SIDE	1
003	TOP / BASE	2
004	LOWER SHELF	2
005	LONGER SHELF	1
006	BACK	1
007	DOOR	2
008	PARTITION	1

PIEZA	DESCRIPCIÓN	CANTIDAD
001	LATERAL IZQUIERDA	1
002	LATERAL DERECHA	1
003	TAPA / BASE	2
004	REPISA MENOR	2
005	REPISA MAYOR	1
006	REVÉS	1
007	PUERTA	2
008	PARTICIÓN	1

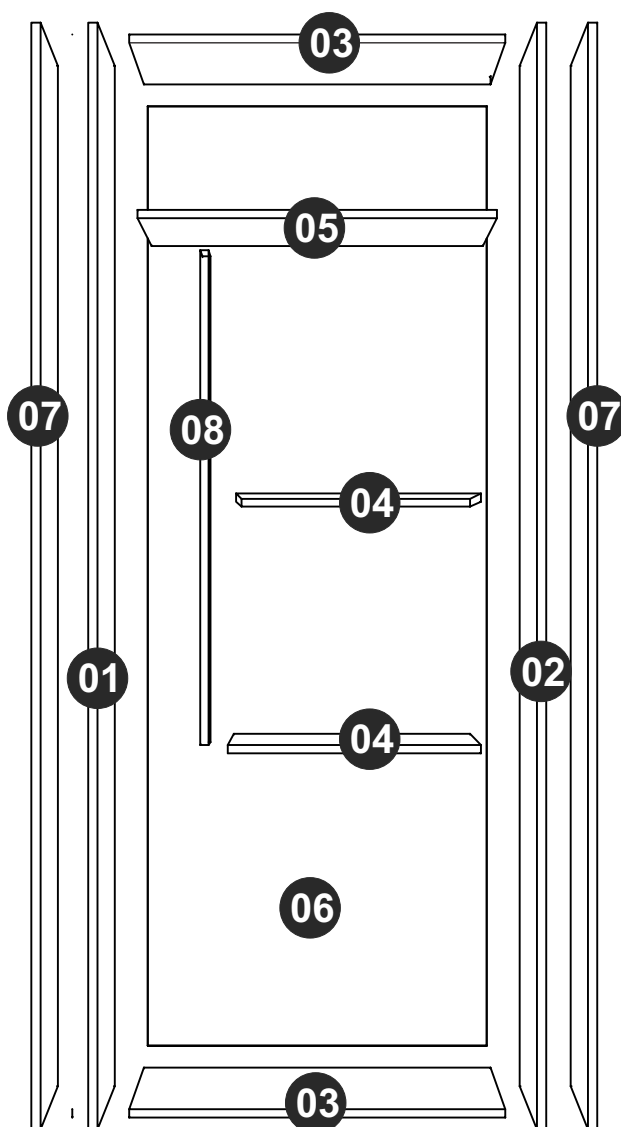



PERFIL PLASTICO x 1  
 PLASTIC PROFILE x 1  
 PERFIL PRASTICO x 1



PÉS x 4  
 FEET x 4  
 PIES x 4



EF 000106 x 24  
 3,5X14 CC



EF 000033x 17  
 8x30



PUXADOR x 2  
 HANDLE x 2  
 MANIJA x 2



EF 000132 X 15  
 4 X 50 CC



EF 000344 X 2



GIZ x 01  
 CHALK x 01  
 TIZA x 01

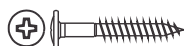

EF 000112 X 4  
 3,5 X 25 CF

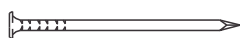

EF 000168 X 50  
 10 X 10 C/C



EF 000248 x 19  
 3,5X14 CP



EF 000024 X 6



EF 000246 X 1  
 5X50 CF



EF 000016 X 1

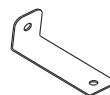

EF 000529 X 1

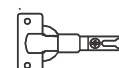

EF 000044 X 6

Utilize para medir as ferragens.

Utilice para medir el herraje.

Use for measuring the hardware.

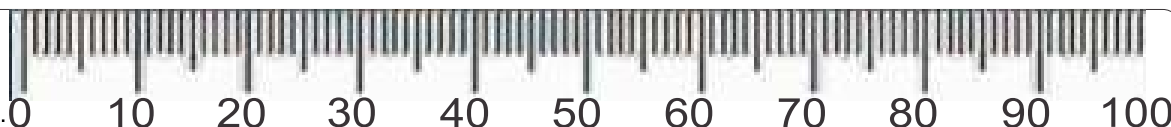

**Garantia (exclusivo para o Brasil/exclusivo de Brasil/exclusive to Brazil):**

A garantia dos produtos fabricados pela BRV Móveis, abrange eventuais defeitos-vícios de fabricação, no prazo estabelecido pelo código de Defesa do Consumidor, em seu artigo 26.II. o qual prevê a garantia de 90 (noventa) dias.

**A** = 8KG - 17.63LB

**B** = 5KG - 11.02LB

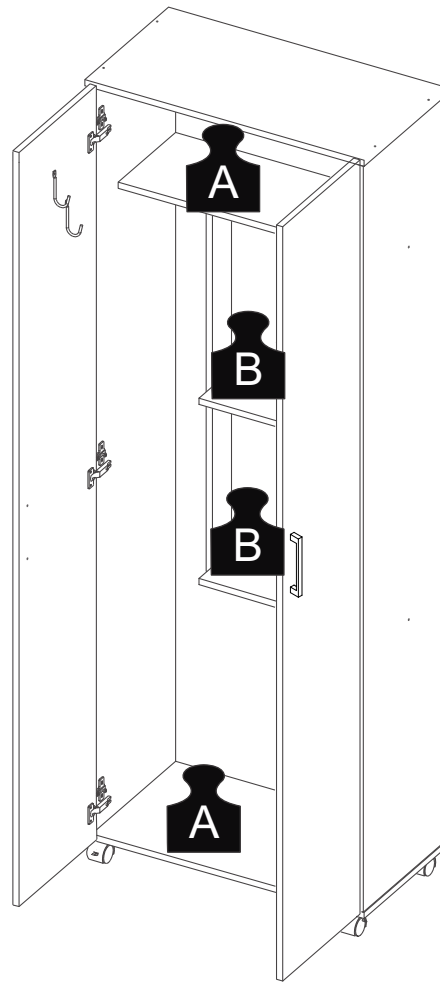

**PASSO 1 / STEP 1 / PASO 1**

Insira a ferragem EF 000033 na peças 01, 02, 04, 05 e 08.  
Insert hardware EF 000033 into pieces 01, 02, 04, 05 and 08.  
Añade el herraje EF 000033 en las piezas 01, 02, 04, 05 y 08.

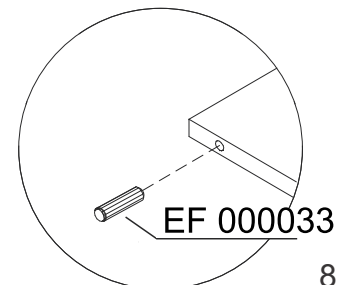
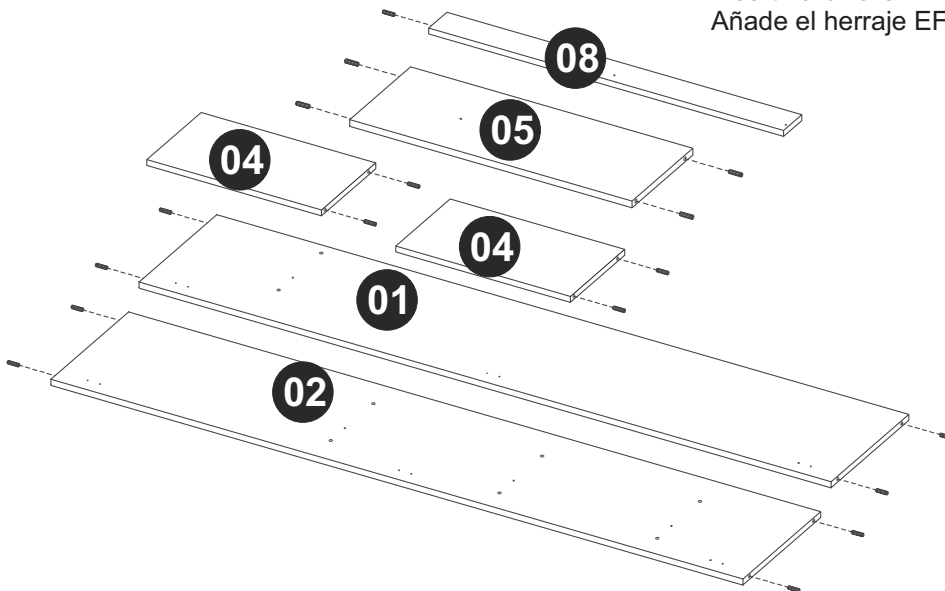



## PASSO 2 / STEP 2 / PASO 2

Fixe a ferragem EF 000024 usando a ferragem EF 000106 nas peças 01 e 02.  
Fix hardware EF 000024 using hardware EF 000106 to pieces 01 and 02.  
Fije el herraje EF 000024 utilizando el herraje EF 000106 en las piezas 01 y 02.

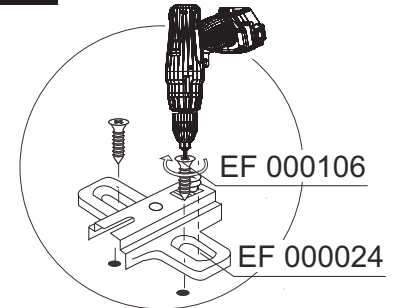
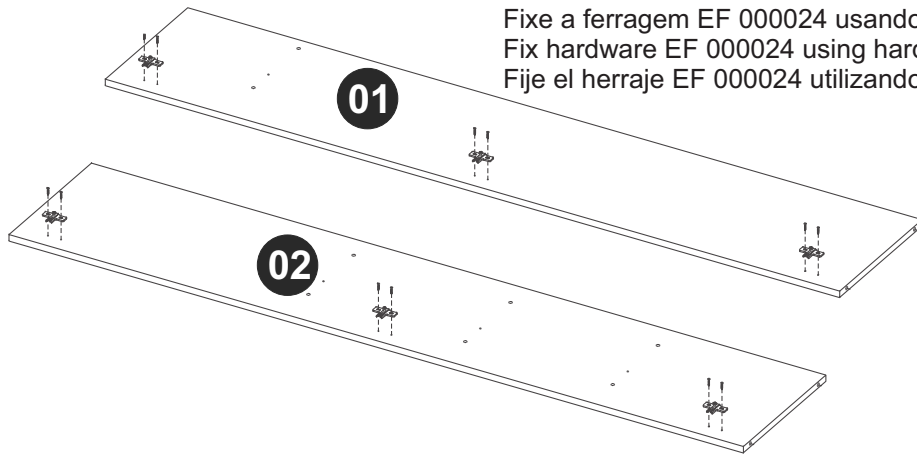

## PASSO 3 / STEP 3 / PASO 3

Fixe o puxador na peça 07 usando a ferragem EF 000112.  
Fixe a ferragem EF 000044 usando a ferragem EF 000106.  
Fix the handle at piece 07 using hardware EF 000112. Fix hardware EF 000044 using hardware EF 000106.  
Fije la manija en la pieza 07 utilizando el herraje EF 000112.  
Fije el herraje EF 000044 utilizando el herraje EF 000106.

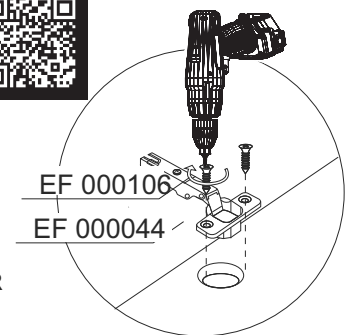
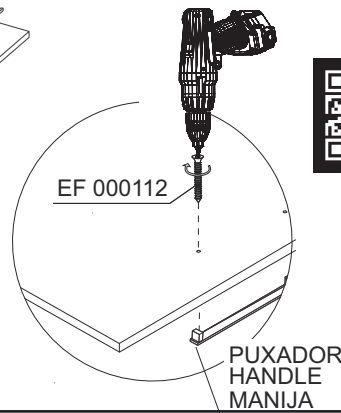
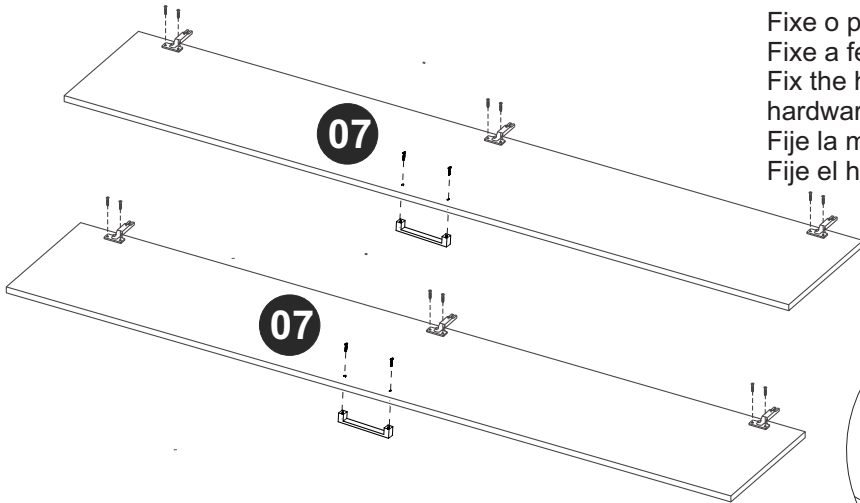

## PASSO 4 / STEP 4 / PASO 4

Fixe as peças 05 e 08 utilizando a ferragem EF 000132.  
Attach pieces 05 and 08 using hardware EF 000132.  
Fije las piezas 05 y 08 utilizando el herraje EF 000132.

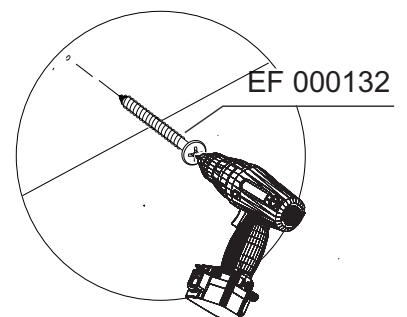
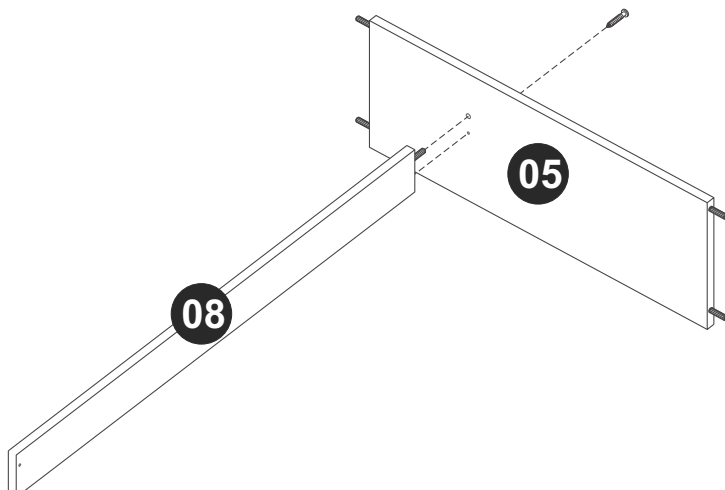

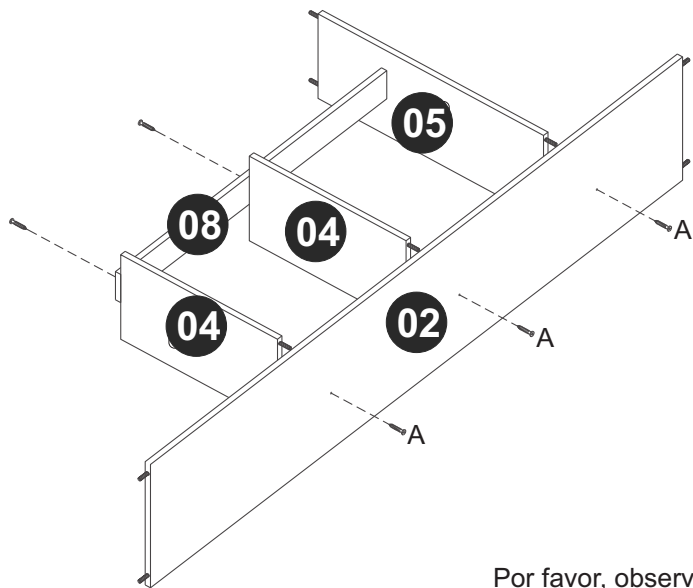

### PASSO 5 / STEP 5 / PASO 5

Fixe as peças 02, 04 e 08 utilizando a ferragem EF 000132.  
 Attach pieces 02, 04 and 08 using hardware EF 000132.  
 Fije las piezas 02, 04 y 08 utilizando el herraje EF 000132.

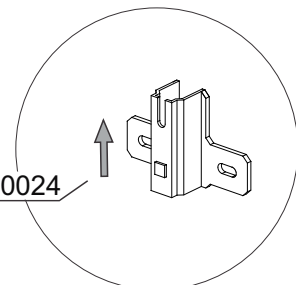
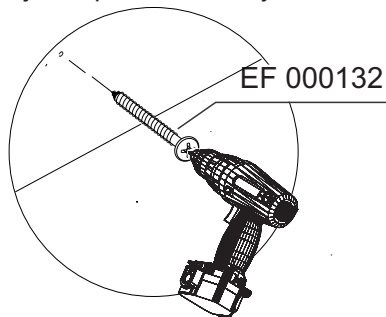

Por favor, observe a posição da ferragem EF 000024  
 Please, note hardware EF 000024 position.  
 Por favor, observe la posición del herraje EF000024.

EF 000024

### PASSO 6 / STEP 6 / PASO 6

Use a ferragem EF 000132 para fixar a peça 01 à parte montada no passo anterior.  
 Use hardware EF 000132 to attach piece 01 to the part assembled in the previous step.  
 Utilice el herraje EF 000132 para juntar la pieza 01 a la parte armada en el paso anterior.

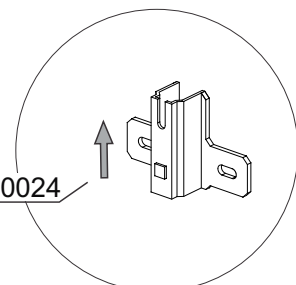
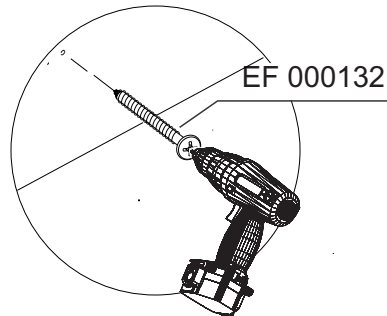
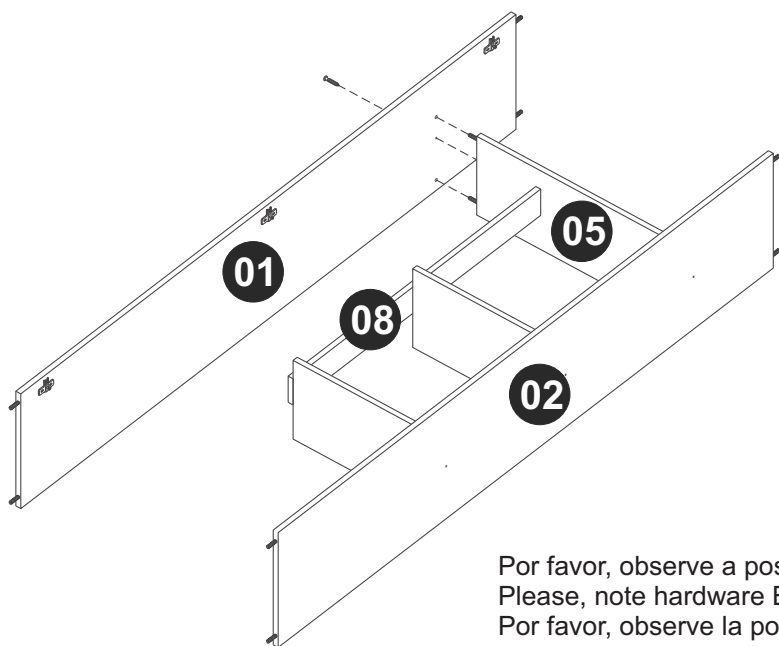

Por favor, observe a posição da ferragem EF 000024  
 Please, note hardware EF 000024 position.  
 Por favor, observe la posición del herraje EF000024.

EF 000024

### PASSO 7 / STEP 7 / PASO 7

Use a ferragem EF 000132 para fixar as peças 03 à parte montada no passo anterior.  
 Use hardware EF 000132 to attach pieces 03 to the part assembled in the previous step.  
 Utilice el herraje EF 000132 para juntar las piezas 03 a la parte armada en el paso anterior.

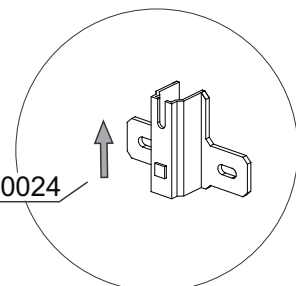
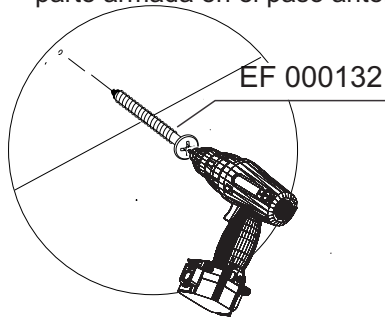
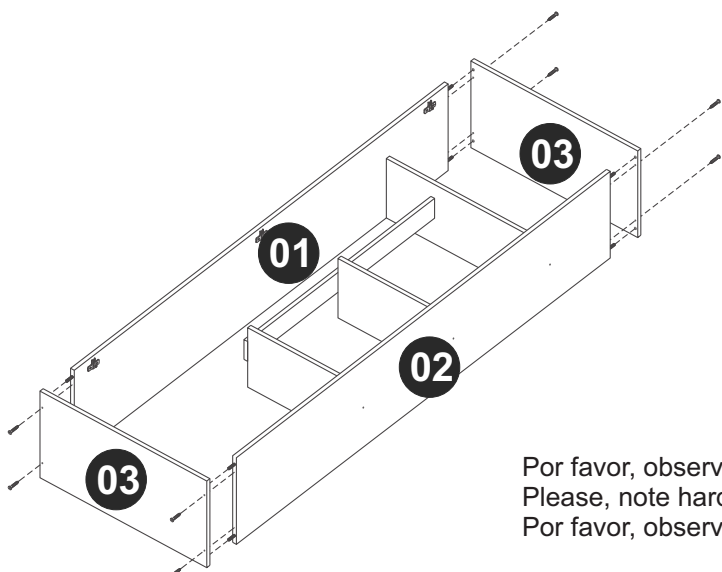

Por favor, observe a posição da ferragem EF 000024  
 Please, note hardware EF 000024 position.  
 Por favor, observe la posición del herraje EF000024.

EF 000024

### PASSO 8 / STEP 8/ PASO 8

Fixe os rodízios utilizando a ferragem EF 000248.  
Attach the casters using hardware EF 000248.  
Fije las ruedas utilizando el herraje EF 000248.

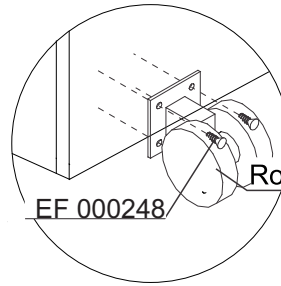
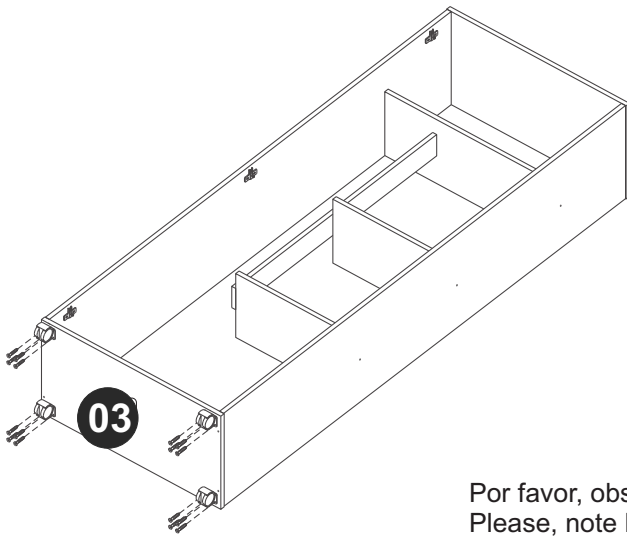

Rodízio/Ruedas/Caster

EF 000248

EF 000024

Por favor, observe a posição da ferragem EF 000024  
Please, note hardware EF 000024 position.  
Por favor, observe la posición del herraje EF000024.

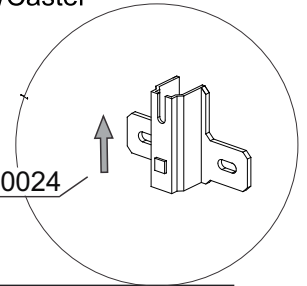

### PASSO 9 / STEP 9 / PASO 9

Use o perfil plástico para unir as peças 06 e fixe ao móvel utilizando a ferragem EF 000168.  
Use the plastic profile to join pieces 06, attach to the furniture using hardware EF 000168.  
Utilice el perfil plastico para juntar las piezas 06, fije al mueble utilizando el herraje EF 000168.

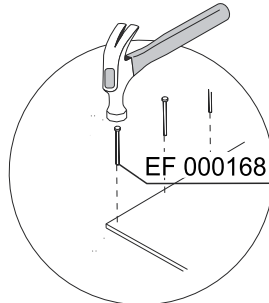
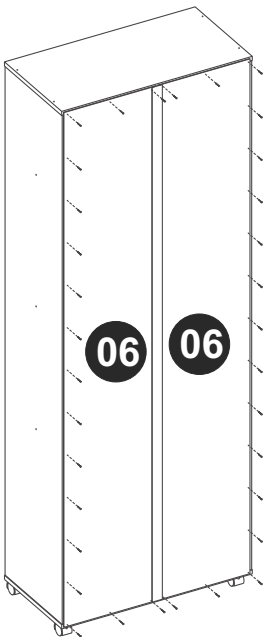

EF 000168

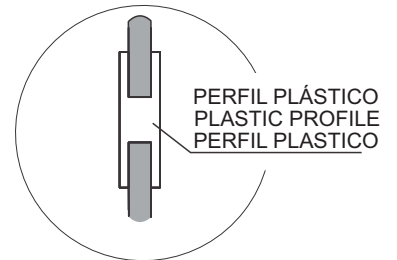

PERFIL PLÁSTICO  
PLASTIC PROFILE  
PERFIL PLASTICO

### PASSO 10 / STEP 10 / PASO 10

Fixe as peças 07, de acordo com a imagem.  
Attach pieces 07, according the image.  
Fije las piezas 07, de acuerdo con la imagen.

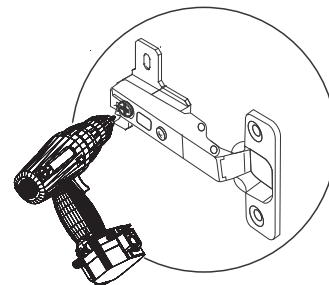
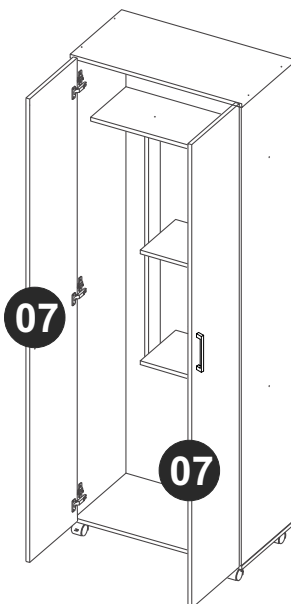

### PASSO 11 / STEP 11 / PASO 11

Fixe a ferragem EF 000344 na peça 07 utilizando a ferragem EF 000248.  
Attach hardware EF 000344 in piece 07 using hardware EF 000248.  
Fije el herraje EF 000344 en la pieza 07 utilizando el herraje EF 000248.

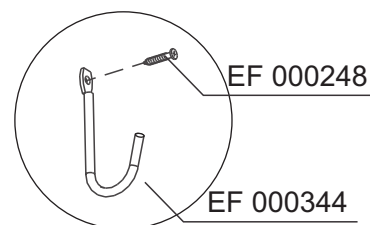
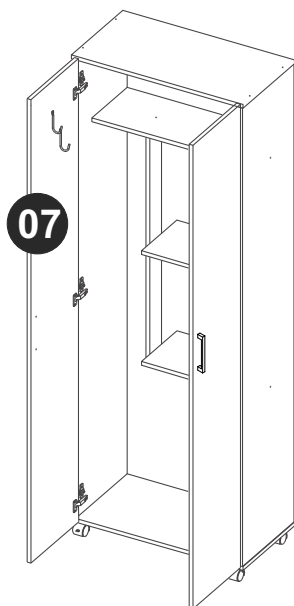

### PASSO 12 / STEP 12 / PASO 12

Use o parafuso EF 000248 para fixar a ferragem EF 000529 ao móvel.  
Use hardware EF 000248 to fix the hardware EF 000529 at the furniture.  
Utilice el herraje EF 000248 para fijar el herraje EF000529 al mueble.

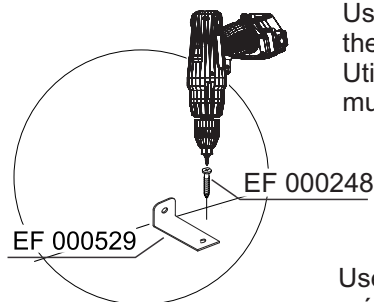
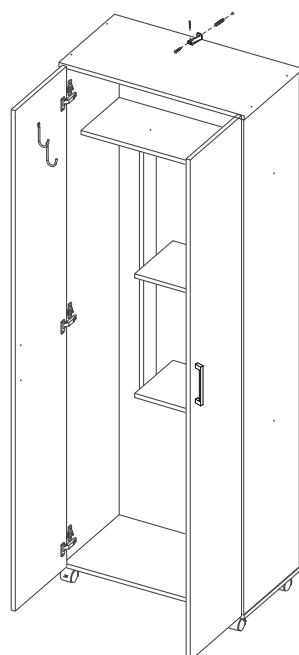

Use as ferragens EF 000246 e EF 000016 para fixar o móvel na parede.  
Use hardwares EF 000246 and EF 000016 for fixing the furniture to the wall.  
Utilice los herrajes EF000246 y EF000016 para fijar el mueble en la pared.

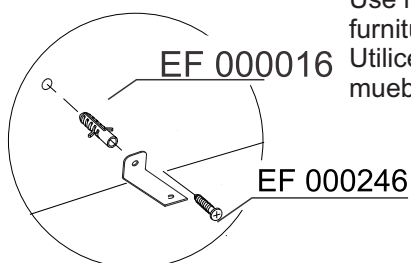

### PASSO 13 / STEP 13 / PASO 13

Use o giz para dar o acabamento final ao produto.  
Use os tapa furos para cobrir os parafusos aparentes.  
Use the chalk to give the final finish on the product.  
Use stickers to cover apparent screws.  
Utilice la tiza para dar el acabado final al producto.  
Utilice los tapa huecos para cubrir los tornillos aparentes.

