

# BB-2610

## Instruções de Montagem Assembly Instructions Instrucciones de Armado

Acesse Vídeos de Montagens  
Access Mounting Videos  
Acceder a los Vídeos de Montaje  
[www.tecnomobili.ind.br](http://www.tecnomobili.ind.br)

**ammo**  
mobili

Estrada RSC 453, Km s/n° | Garibaldi | RS  
CEP: 95720-000 | Fone / Fax: 54.3464.2050  
[sac@moveisvideira.com.br](mailto:sac@moveisvideira.com.br)

### Lista de Peças / List of pieces / Lista de piezas

C6D	DESCRIÇÃO	DESCRIPTION	DESCRIPCIÓN	QTD	RAW MATERIAL	DIMENSION	CÓD
01	Tampo	Top	Tapa	01	MDP 25mm	1600x360x25mm	702609
02	Lateral Esquerda	Left Side	Lateral Izquierda	01	MDP 25mm	680x360x25mm	312610
03	Lateral Direita	Left Right	Lateral Derecha	01	MDP 25mm	680x360x25mm	302610
04	Prateleira Móvel Maior	Larger Mobile Shelf	Estante Móvil Maior	01	MDP 15mm	1024x224x25mm	202609
05	Pilastra	Pillar	Pilar	01	MDP 15mm	343x125x15mm	652609
06	Travessa do Pega	Touch Traverse	Traviessa de Toque	01	MDP 15mm	1548x45x15mm	602609
07	Travessa	Traverse	Traviessa	01	MDP 15mm	1548x45x15mm	612609
08	Costa	Back	Costa	02	MDP 3mm	1570x350x3mm	402609
09	Divisão	Division	División	01	MDP 15mm	680x344x15mm	502610
10	Base	Base	Base	01	MDP 25mm	1600x360x25mm	102609
11	Roda Pé Frontal	Front Baseboard	Roda Pié Frontal	01	MDP 15mm	1520x132x15mm	812609
12	Roda Pé Traseiro	Back Baseboard	Roda Pié Posterior	01	MDP 15mm	1520x132x15mm	802609
13	Roda Pé Menor Lateral	Bottom Side Baseboard	Roda Pié Menor Lateral	02	MDP 15mm	300x132x15mm	822609
14	Roda Pé Menor Interno	Internal Bottom Baseboard	Roda Pié Menor Interno	02	MDP 15mm	300x132x15mm	832609
15	Aplik	Aplik	Aplik	03	MDP 15mm	1518x25x15mm	852609
16	Porta	Door	Puerta	03	MDP 15mm	642x513x15mm	82610
17	Frente de Gaveta	Front Drawer	Frente Cajón	01	MDP 15mm	467x125x15mm	92609
18	Costa de Gaveta	Back Drawer	Costa de Cajón	01	MDP 15mm	453x125x15mm	412609
19	Lateral de Gaveta	Drawer Side	Lateral de Cajón	02	MDP 15mm	298x125x15mm	312609
20	Fundo de Gaveta	Bottom Drawer	Fondo Gaveta	01	MDP 3mm	431x306x3mm	422609

#### Notas Especiais:

**01** -Examine completamente todas as peças do móvel antes de começar o trabalho.

**02** -Recomenda-se montar o móvel conforme este Manual de Montagem.

**03** -É de responsabilidade do montador seguir as instruções do Manual de Montagem, que são fundamentais para garantir a estrutura do móvel.

**04** -Para limpeza, utilizar somente pano úmido e sabão neutro.

#### Special notes:

**01** -Check all parts of the unit thoroughly before starting work.

**02** -It is recommended to assemble the furniture according to this Installation Manual.

**03** -It is the responsibility of the assembler to follow the instructions in the Assembly Manual, which are essential to ensure the structure of the furniture.

**04** -For cleaning use only damp cloth and neutral soap.

#### Notas especiales:

**01** -Examine completamente todas las piezas del mueble antes de iniciar el trabajo.

**02** -Se recomienda montar el mueble conforme el Manual de Ensamblaje.

**03** -Es de responsabilidad del montador seguir las instrucciones del Manual de Ensamblaje, que son fundamentales para garantizar la estructura del mueble.

**04** -Para limpieza solamente usar trapo húmedo y jabón neutro.

#### Guarante certificate:

The guarantee of products manufactured by Móveis Videira LTDA covers any defects / manufacturing defects, within the period established by the Consumer Protection Code, in its Article 26, II, which provides for a legal guarantee of ninety (90) days.

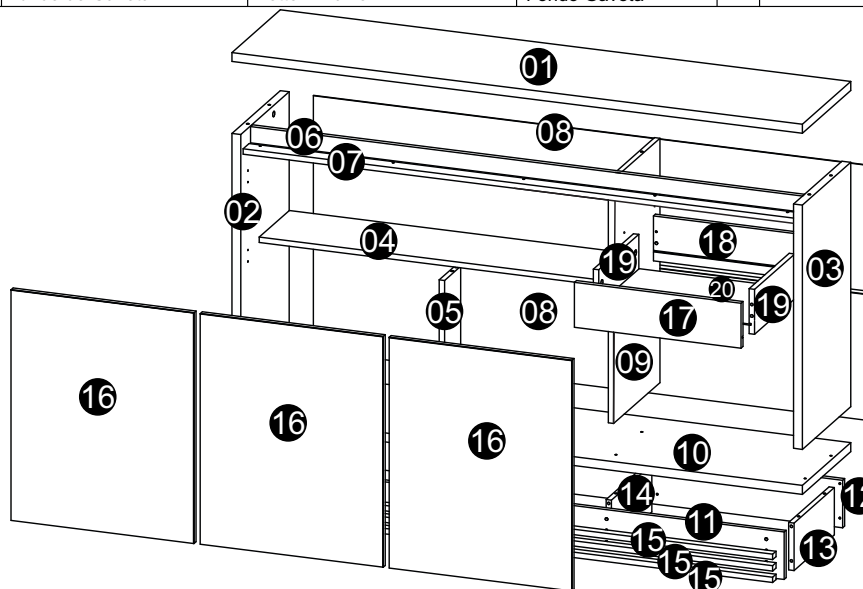





#### Ferramentas | Tools | Herramientas





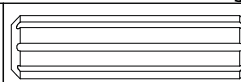

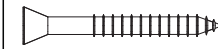



Use the ruler below to measure the components

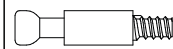

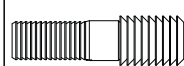
### TAMANHO REAL - TAMANO VERDADERO - REAL SIZE

REF	DESCRIÇÃO	QTD	CÓD
A	 Cavilha 8 x 30mm	08	2806
B	 3,5 x 14mm CC	32	3639
C	 Parafuso 3,5x25 CC	05	0286
D	 3,5 x 14mm CF	04	3814

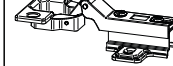
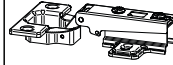
### LUSTRAÇÃO - ILUSTRACION - ILLUSTRATION

REF	DESCRIÇÃO	QTD	CÓD
E	 Bigfer Corrediça 300mm	01	7312
F	 34 x 7mm Parafuso Minifix	42	3771
G	 15 x 12mm Tambor Minifix	42	9516
H	 22x3mm Prego 10x10	55	3051
I	 Cavilha Escalonada 6x8mm	12	8670
J	 14x8x5mm c/Estria Suporte Prateleira	04	3748
K	 Tapa Furo	06	
L	 14 x 4mm Sapata Deslizadora	08	8112
M	 32x45x20mm Distanciador de corrediça	02	6522
N	 Dobradiça Alta Albras 35mm Calço N°8	04	5797
O	 Dobradiça Reta Albras 35mm Calço N°8	02	6606
P	 13 x 13 x 3mm Fixador de Costa	01	6524
Q	 Perfil I 1550mm	01	

Revisão: 02  
Data: 12/05/2022

# BB-2610

Instruções de Montagem  
Assembly Instructions  
Instrucciones de Armado

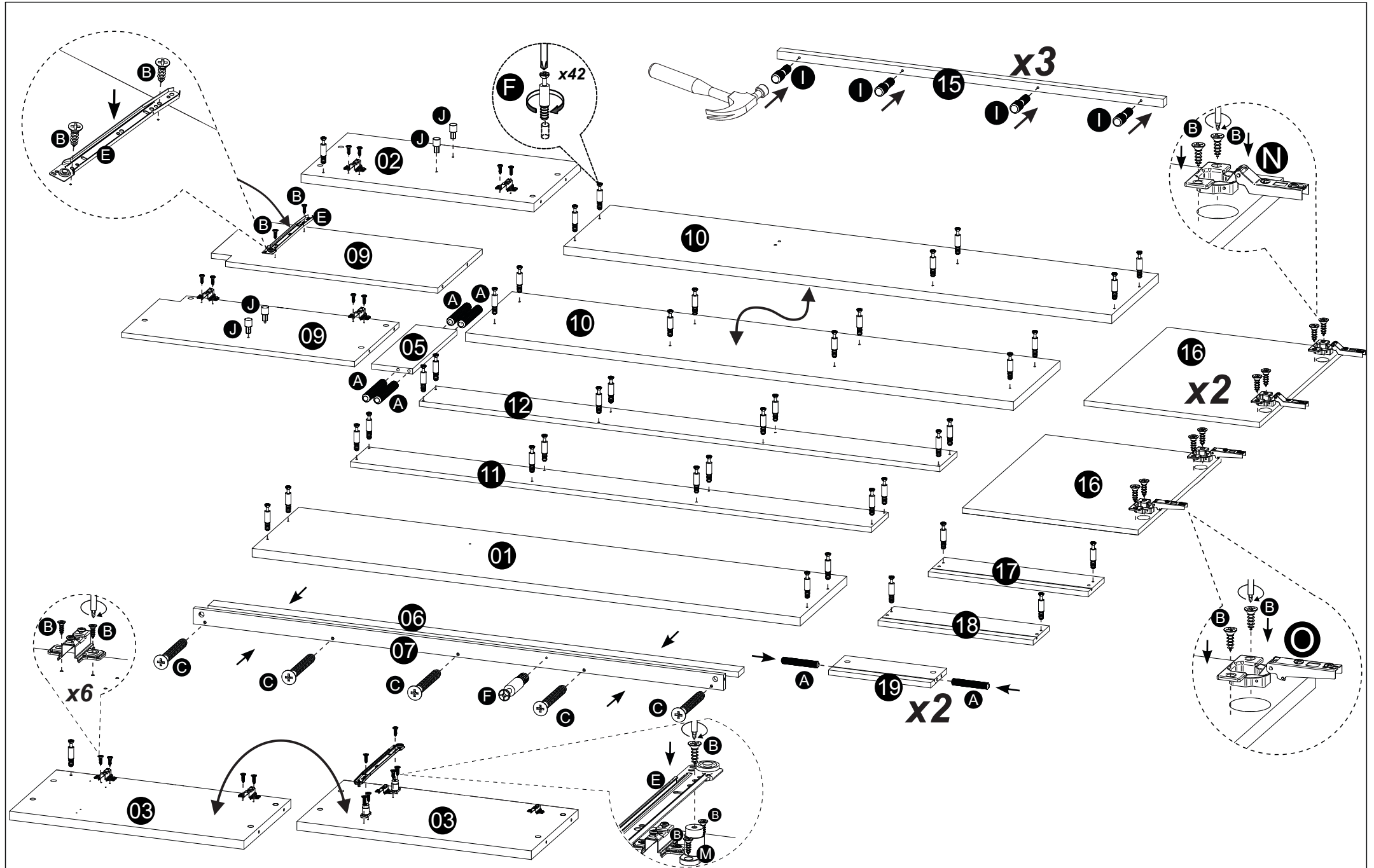

01

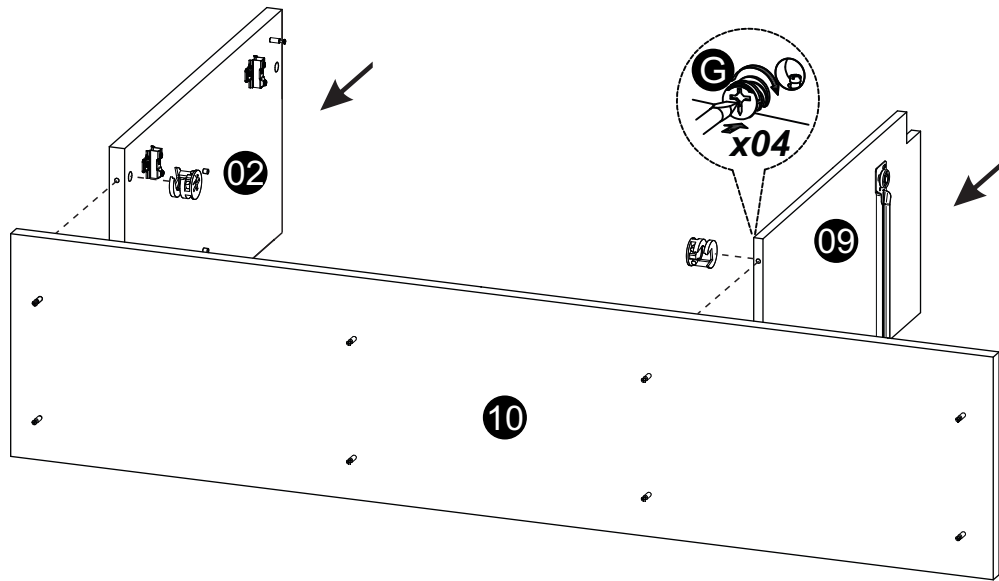

02

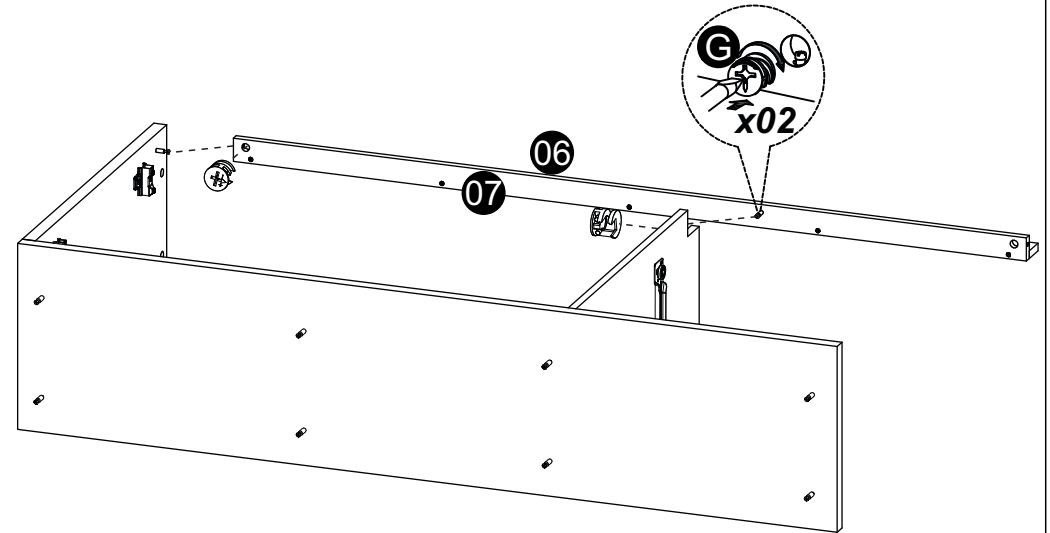

03

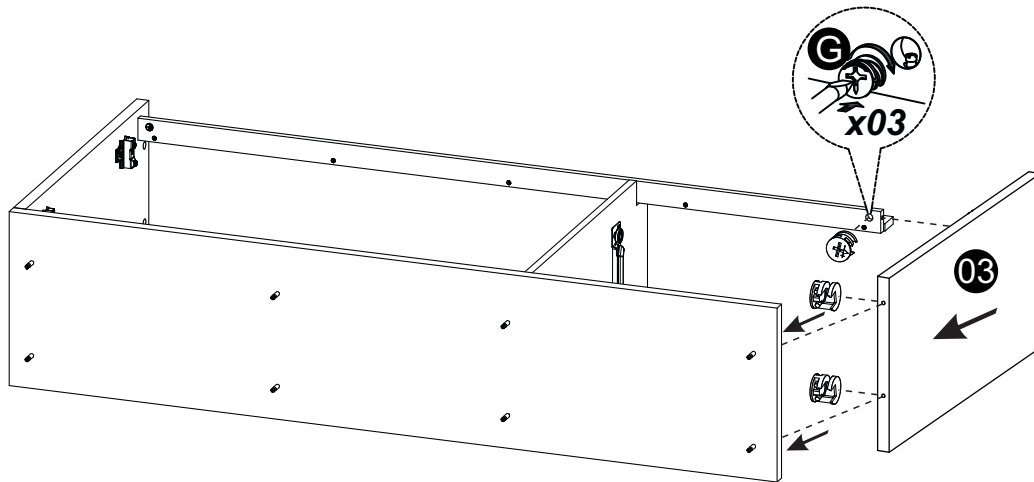

04

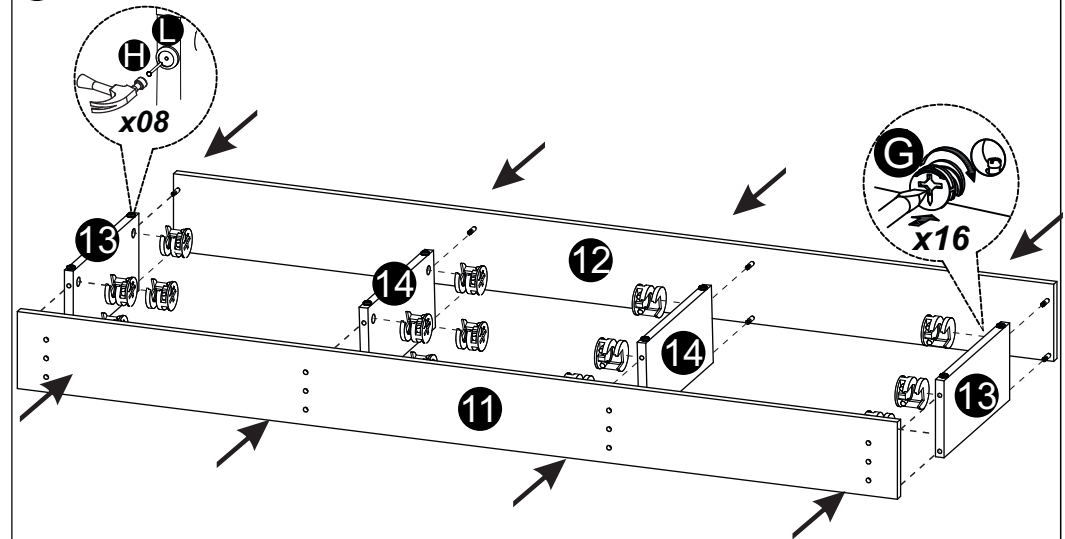

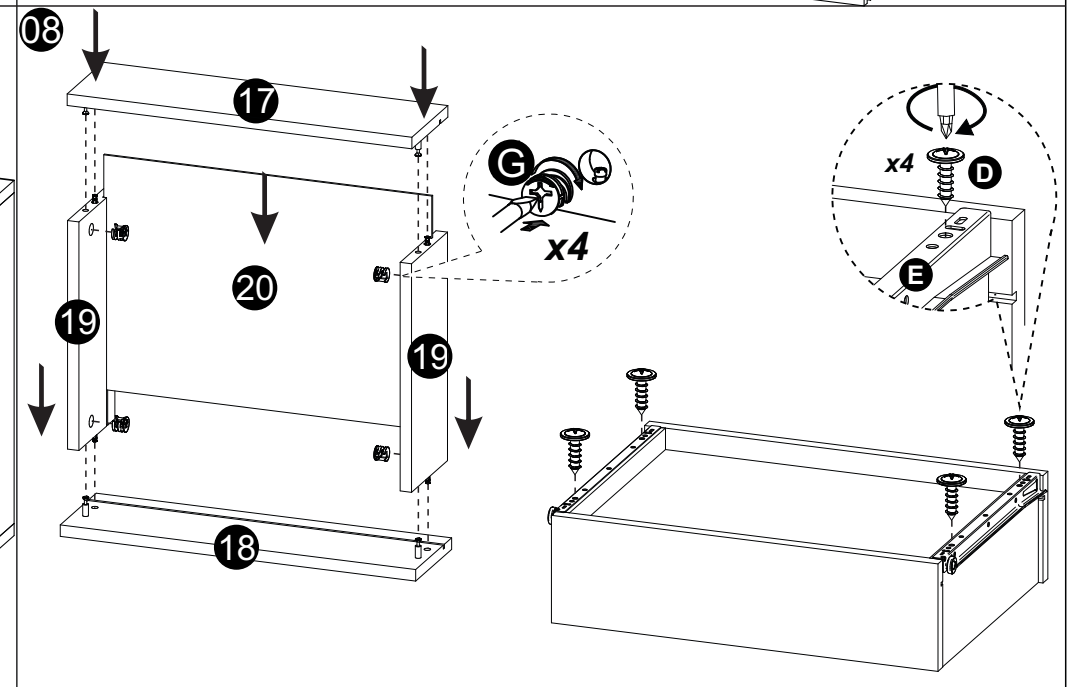
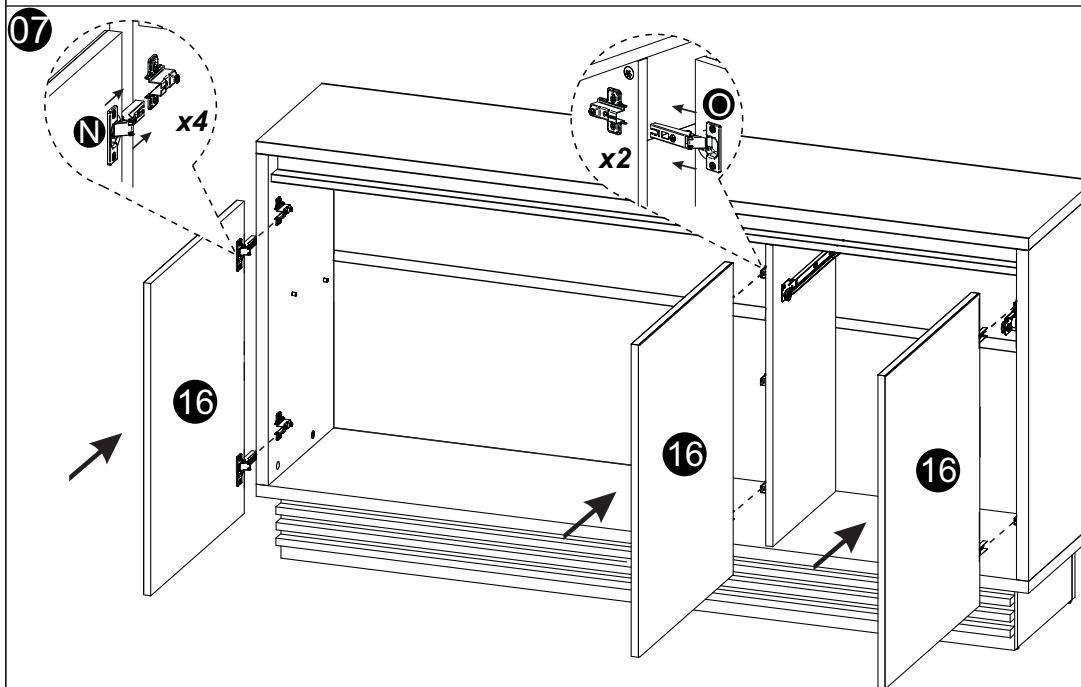
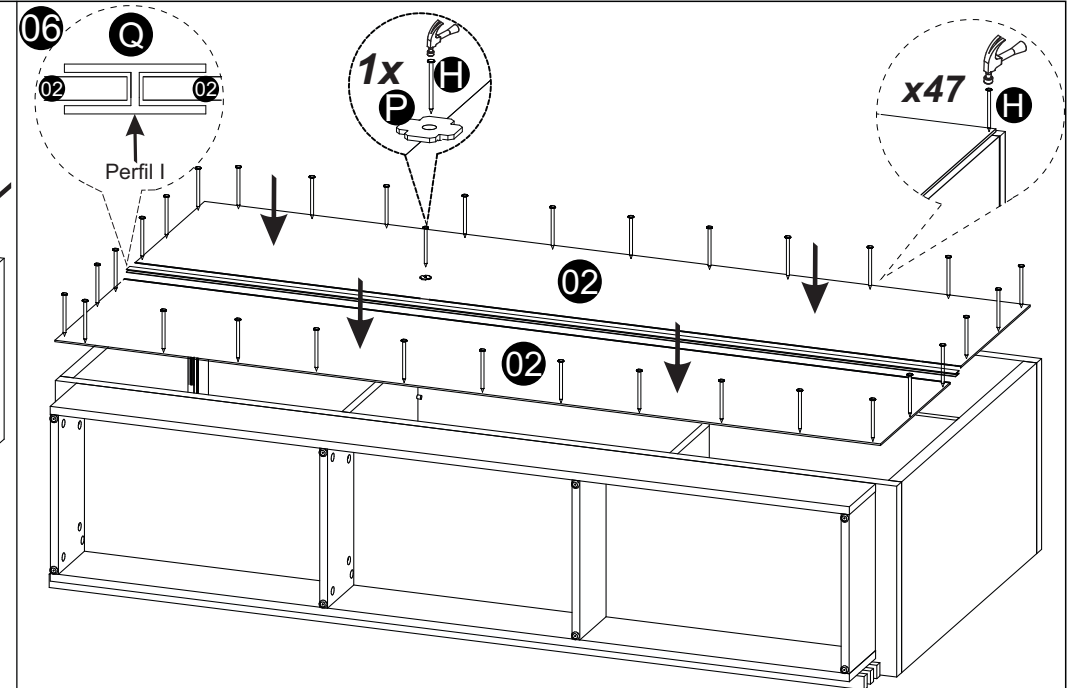
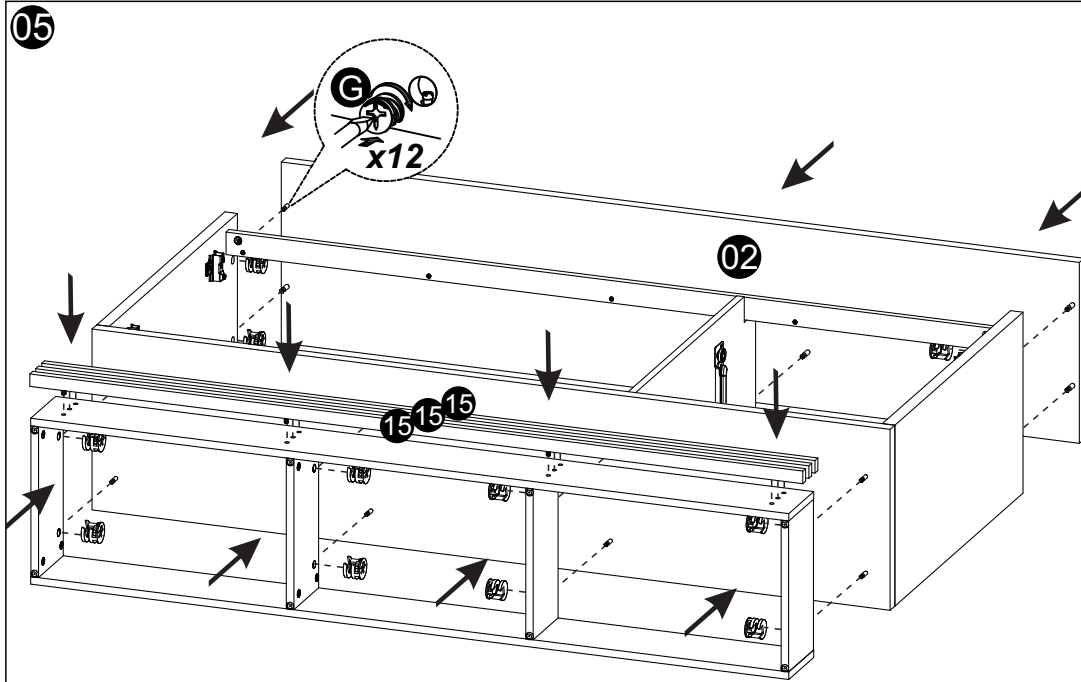

09

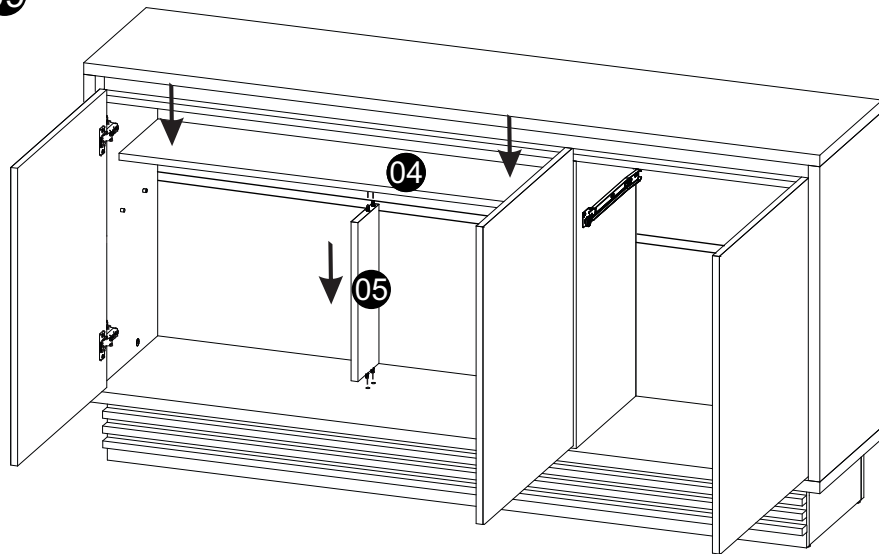

10

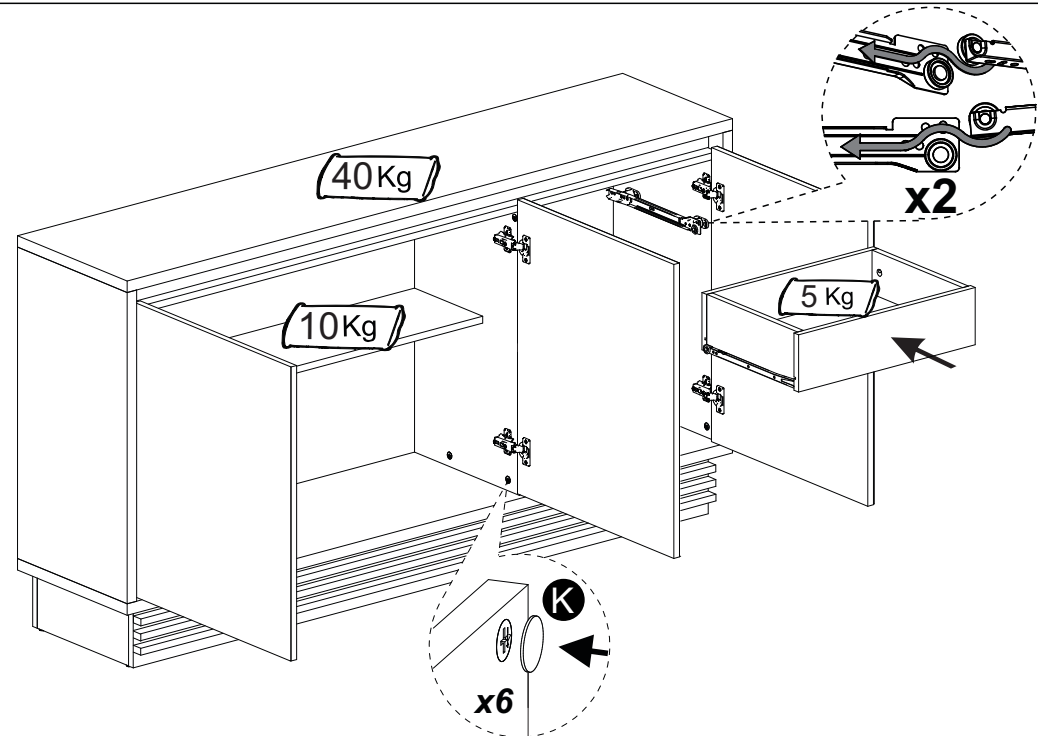

**IMPORTANTE:** ANTES DE ENCAIXAR A GAVETA REGULE AS PORTAS, SÓ APÓS A REGULAGEM A GAVETA DEVE SER ENCAIXADA.

**IMPORTANT:** BEFORE FITTING THE DRAWER, ADJUST THE DOORS ONLY AFTER ADJUSTMENT THE DRAWER MUST BE FITTED.

**IMPORTANTE:** ANTES DE COLOCAR EL CAJÓN, AJUSTE LAS PUERTAS, SOLO DESPUÉS DEL AJUSTE DEBE INSTALARSE EL CAJÓN.

**Ajuste das Portas**  
**Ajustes de las Puertas**  
**Doors Adjustment**

