

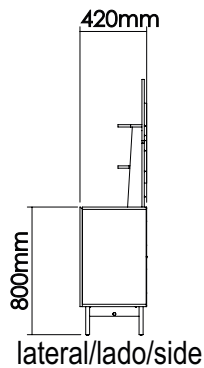

Cantinho Café Viena

Aparador de café Viena / Vienna coffee sideboard
Versão 1.0 / Versión 1.0 / Version 1.0

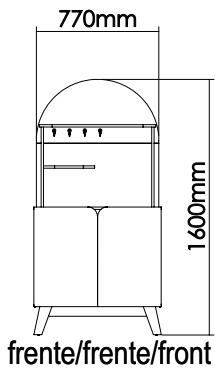

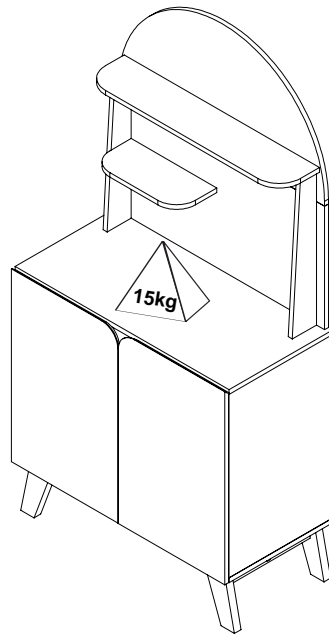
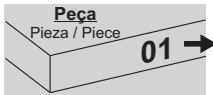



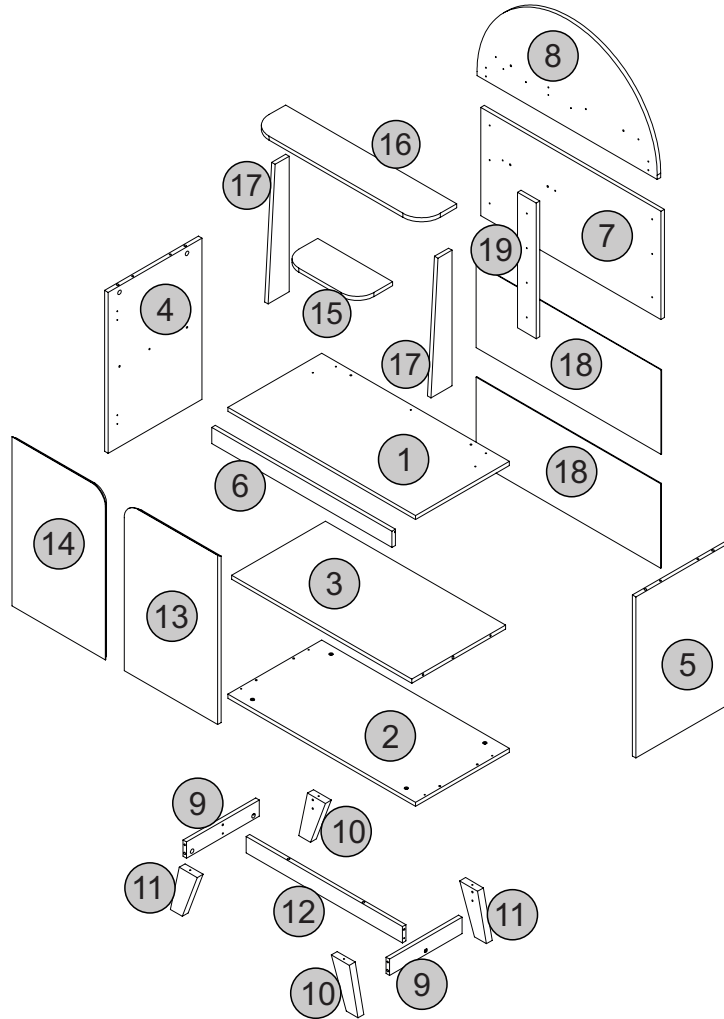
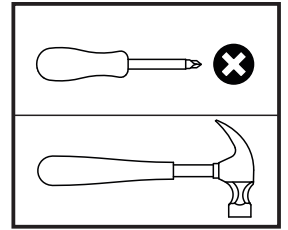







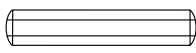

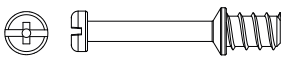

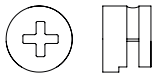
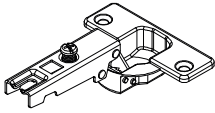
- O número na borda da peça corresponde ao manual.
- Para retirada do número usar Lustra-Móveis, Alcool em Gel ou Borracha.
- El número en el borde de la pieza coincide con el manual.
- Use una goma de borrar blanca, alcohol en gel o lustrador para muebles para eliminar los números.
- The number on the edge of the piece matches the manual.
- Use a White eraser, Alcohol Gel or Furniture Polish to remove the numbers.

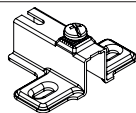

| Descrição | Descripción | Description | Qty |
|---|--------------------------|---------------------|-----|
| 1-Tampo (800x400x15mm) | 1-Tapa | 1-Top | 1 |
| 2-Base (800x400x15mm) | 2-Base | 2-Base | 1 |
| 3-Prateleira Fixa (678x400x15mm) | 3-Estante Fijo | 3-Fixed Shelf | 1 |
| 4-Lateral Esquerda (595x400x15mm) | 4-Lado izquierdo | 4-Left side | 1 |
| 5-Lateral Direita (595x400x15mm) | 5-Lado derecho | 5-Right side | 1 |
| 6-Travessa Porta (768x60x15mm) | 6-Bandeja de puerta | 6-Door Tray | 1 |
| 7-Painel Traseiro Inferior (768x400x15mm) | 7-Panel trasero inferior | 7-Lower Back Panel | 1 |
| 8-Painel Traseiro Superior (768x400x15mm) | 8-Panel trasero superior | 8-Top Back Panel | 1 |
| 9-Travessa dos Pés (310x60x15mm) | 9-Riel de Pie | 9-Foot Rail | 2 |
| 10-Pé Esquerdo (180x77x25mm) | 10-Pie Izquierdo | 10-Left Foot | 2 |
| 11-Pé Direito (180x77x25mm) | 11-Pie Derecho | 11-Right Foot | 2 |
| 12-Travessa Base (666x60x15mm) | 12-Bandeja básica | 12-Base Tray | 1 |
| 13-Porta Direita (625x398x15mm) | 13-Puerta derecha | 13-Right Door | 1 |
| 14-Porta Esquerda (625x398x15mm) | 14-Puerta izquierda | 14-Left Door | 1 |
| 15-Prateleira Menor (320x150x15mm) | 15-Estante más pequeño | 15-Smaller Shelf | 1 |
| 16-Prateleira Superior (730x150x15mm) | 16-Estante superior | 16-Top Shelf | 1 |
| 17-Travessa (500x90x15mm) | 17-Plato | 17-Platter | 2 |
| 18-Traseiro (788x312x3mm) | 18-Trasero | 18-Rear | 2 |
| 19-Travessa Traseiro (500x80x15mm) | 19-Travesaño trasero | 19-Rear Crossmember | 1 |

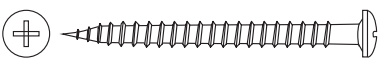
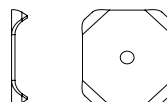
Lista de Materiais

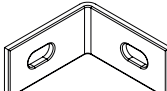
Lista de Materiales/ Hardware List

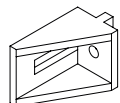
| | | | | | | | |
|----------|---|--|-----------|----------|---|---|-----------|
| A |  | Cavilha / Tarugo / Dowel Ø6x30mm | 22 | J |  | Parafuso / Tornillo / Screw / Ø4,0x20mm CP | 04 |
| B |  | Minifix / Minifix / Minifix Ø7x30mm | 12 | K |  | Gancho / Gancho / Hook / | 04 |
| C |  | Tambor / Tambor / Minifix Cam Ø15x12mm | 12 | L |  | Dobradiça / Bisagra / Hinge / | 04 |
| D |  | Tapa furo adesivo / Adhesivo / Hole Cover Ø18mm | 18 | M |  | Calço Dobradiça / Cuña de Bisagra / Hinge Shim / | 04 |
| E |  | Parafuso Tornillo / Screw Ø4x14mm CP | 26 | N |  | Sapata Fixa / Pata Fija / Fixed Foot Ø5,0x10mm | 04 |
| F |  | Parafuso Tornillo / Screw Ø3,5x12mm CC | 04 | O |  | Prego / Clavo / Nail 8x8 | 25 |
| G |  | Parafuso / Tornillo / Screw / Ø3,5x40mm CP | 25 | P |  | Fixador / fijador / Fixator | 05 |
| H |  | Parafuso / Tornillo / Screw / Ø3,5x25mm CF | 02 | Q |  | Cantoneira / Esquina / Coner | 02 |
| I |  | Parafuso / Tornillo / Screw / Ø5,0x40mm CF | 06 | R |  | Suporte / Soporte / Suport | 03 |

DICAS PARA FIXAR MINIFIX

TIP TO FASTEN THE MINIFIX
PISTA PARA ARREGLAR EL MINIFIX



Produto Moldado / Silicona / Silicone
8mm

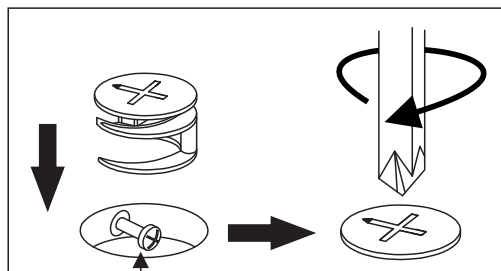

Cabeça do parafuso precisa estar no centro

La cabeza del tornillo debe estar en el centro
Screw head has to be in the center

Parafuso Minifix

Tornillo minifix/Minifix screw

Fixe o parafuso até o ressalto encostar na superfície da peça (veja o exemplo abaixo).

Tighten the screw until its overhang part lean on the piece surface (see the example below).

Fije el tornillo hasta que su parte sobresaliente toque la superficie de la pieza (vea el ejemplo abajo).

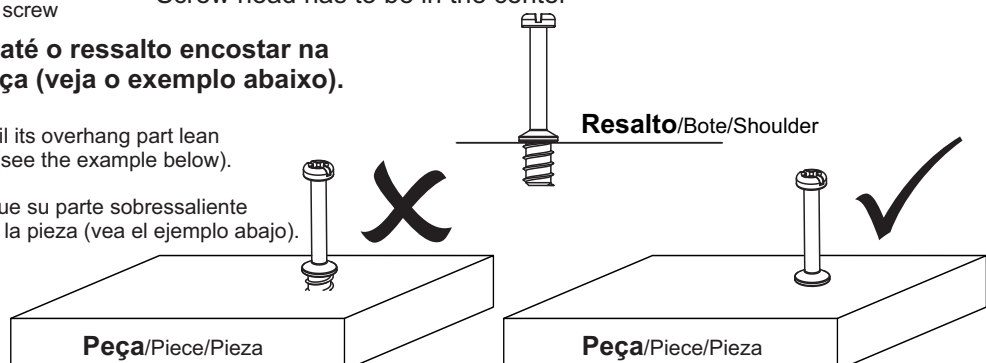

Passo 1

Paso/Step

PEÇA
Pieza/Piece

1 - TAMPO x1

FERRAGEM
Herraje/Hardware

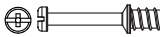
B  04

FERRAMENTA
Herramienta/Tool

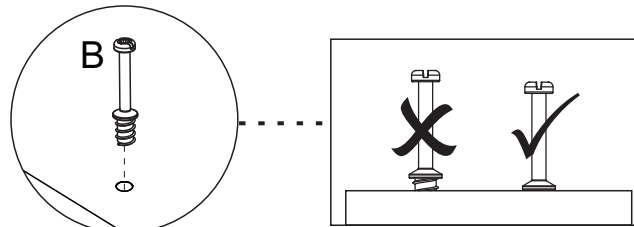
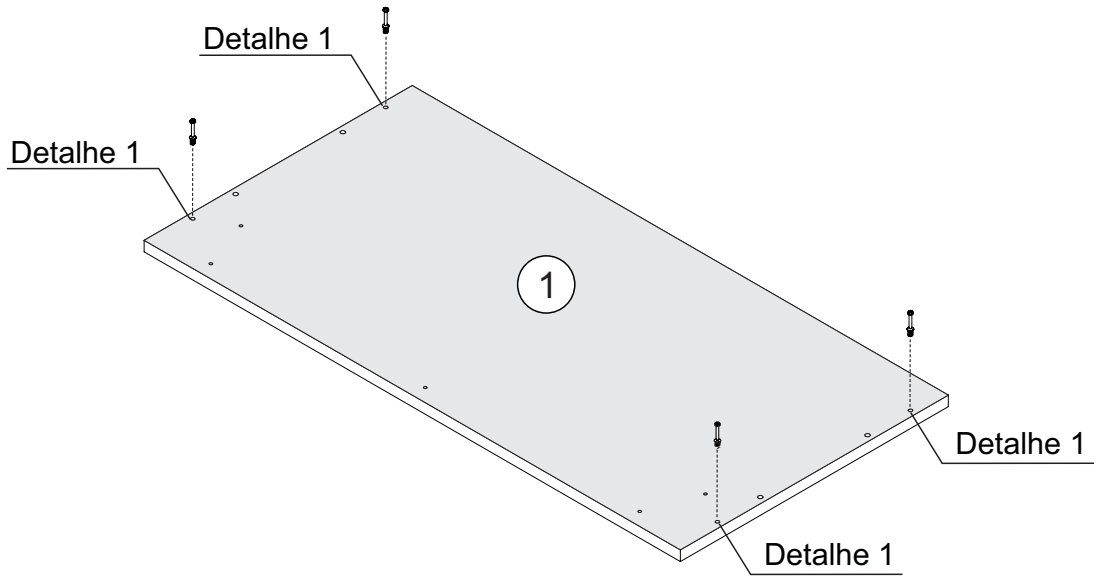
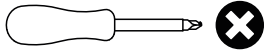

Detalhe 1
Detalle/Detail

Passo 2

Paso/Step

PEÇA
Pieza/Piece

3 - PRATELEIRA FIXA x1

FERRAGEM
Herraje/Hardware

A  04

FERRAMENTA
Herramienta/Tool

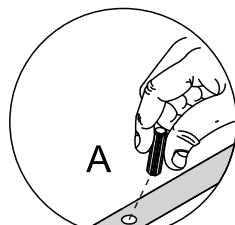
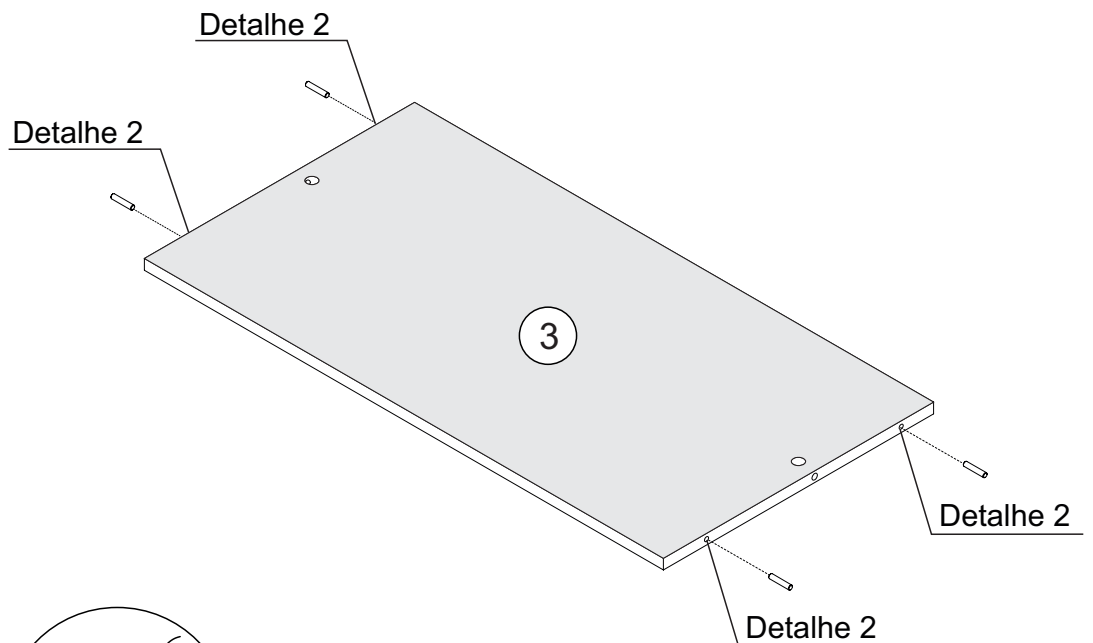
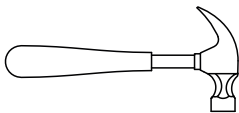

Detalhe 2
Detalle/Detail

Passo 3

Paso/Step

PEÇA
Pieza/Piece

4 - LATERAL ESQUERDA x1

FERRAGEM
Herraje/Hardware

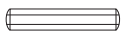
A  04

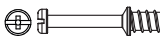
B  01

E  04

M  02

FERRAMENTA
Herramienta/Tool

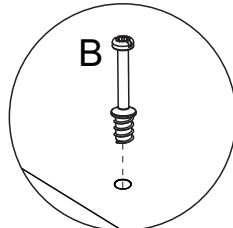
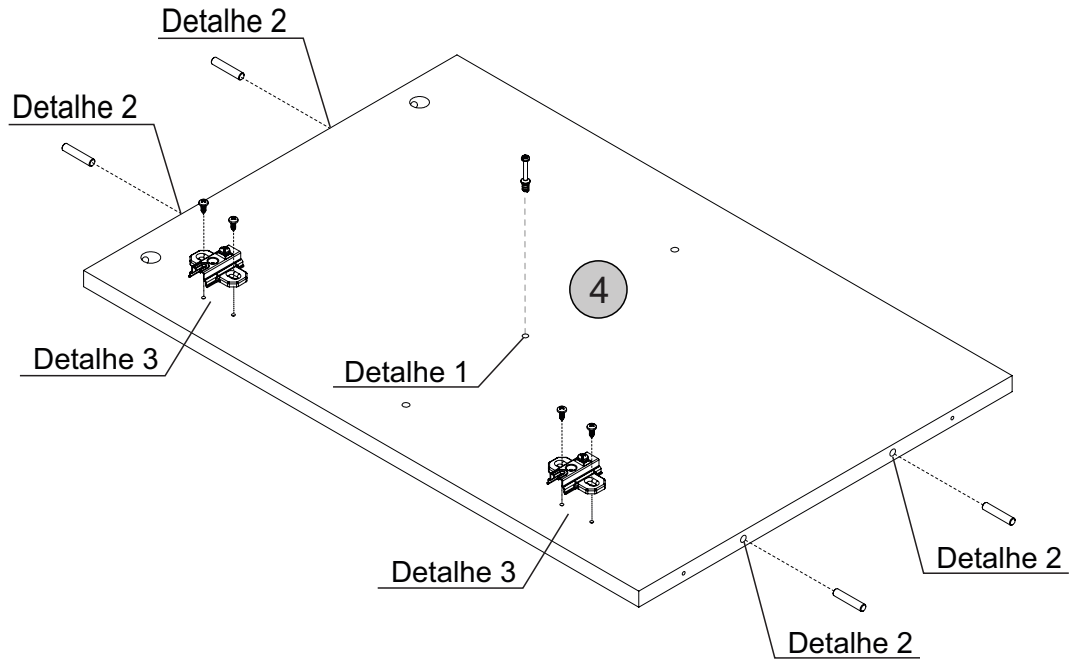
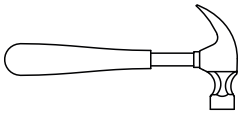
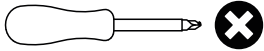

Detalhe 1
Detalle/Detail

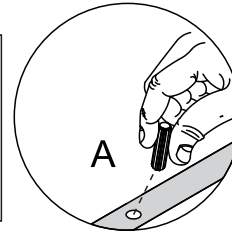
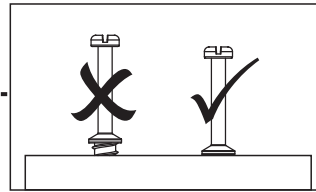

Detalhe 2
Detalle/Detail

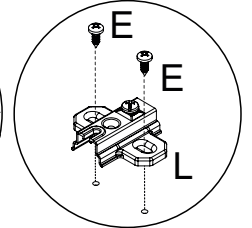

Detalhe 3
Detalle/Detail

Passo 4

Paso/Step

PEÇA
Pieza/Piece

5 - LATERAL DIREITA x1

FERRAGEM
Herraje/Hardware

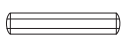
A  04

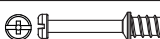
B  01

E  04

M  02

FERRAMENTA
Herramienta/Tool

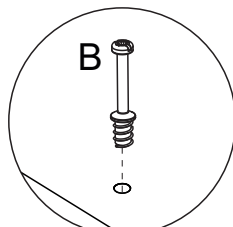
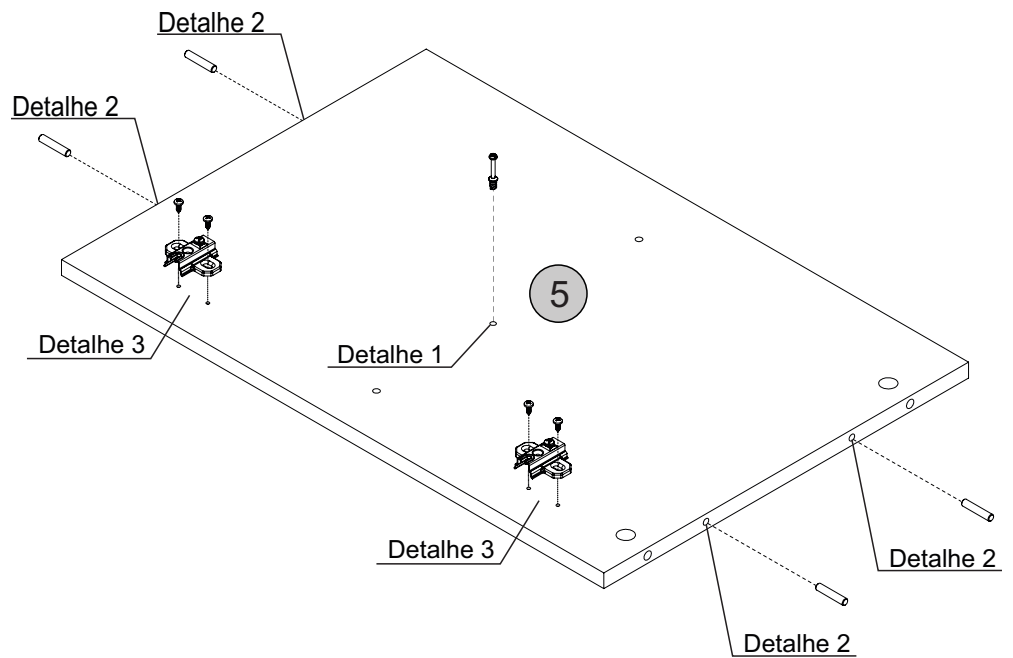
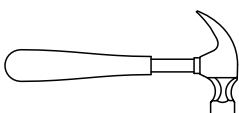
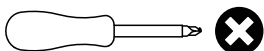

Detalhe 1
Detalle/Detail

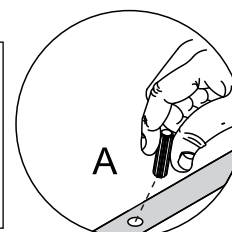
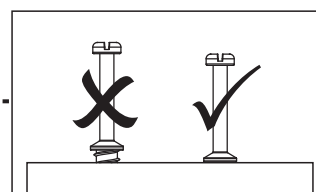

Detalhe 2
Detalle/Detail

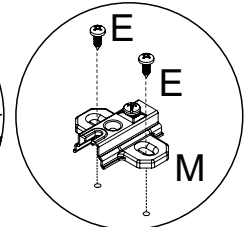

Detalhe 3
Detalle/Detail

Passo 5

Paso/Step

PEÇA

Pieza/Piece

7 - PAINEL TRASEIRO INF. x1

FERRAGEM

Herraje/Hardware

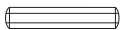
A  02

FERRAMENTA

Herramienta/Tool

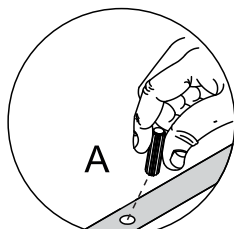
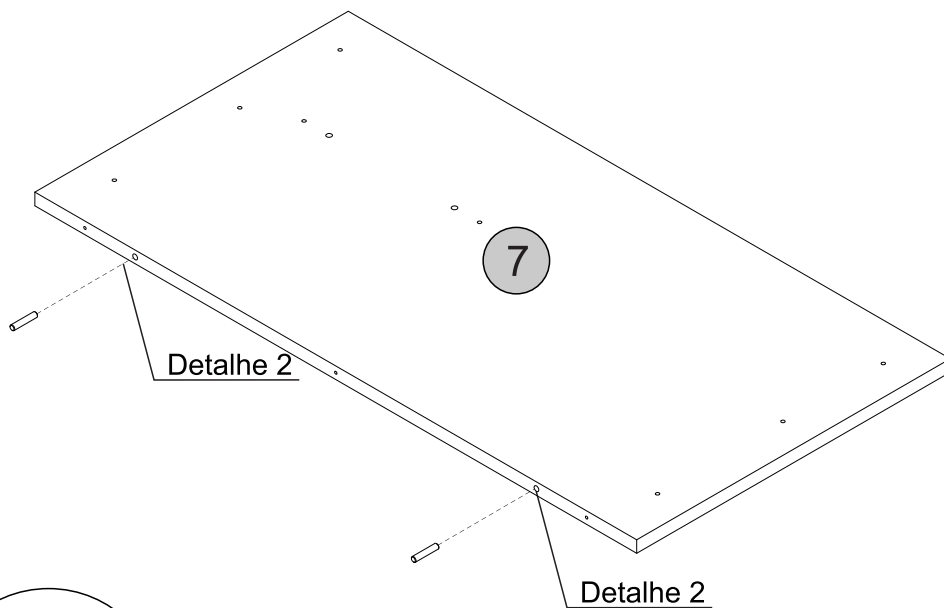
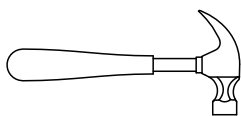

Detalhe 2
Detalle/Detail

Passo 6

Paso/Step

PEÇA

Pieza/Piece

8 - PAINEL TRASEIRO SUP. x1

FERRAGEM

Herraje/Hardware

F  04

K  04

FERRAMENTA

Herramienta/Tool

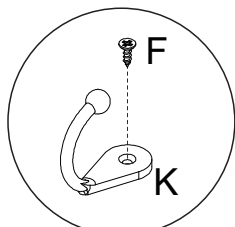
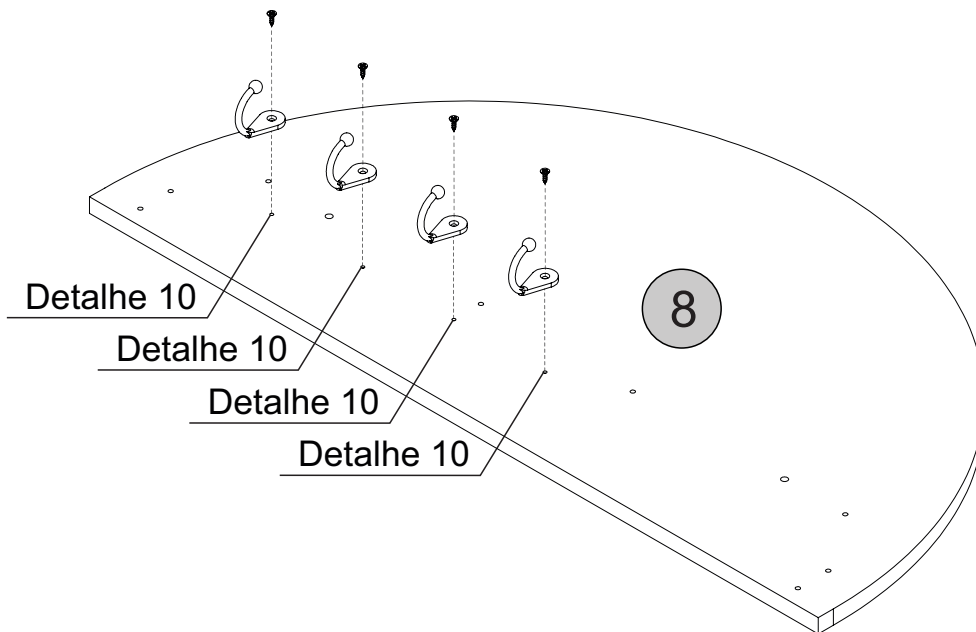
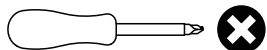

Detalhe 10
Detalle/Detail

Passo 7

Paso/Step

PEÇA

Pieza/Piece

16 - PRATELEIRA SUPERIOR x1

FERRAGEM

Herraje/Hardware

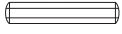
A  02

FERRAMENTA

Herramienta/Tool

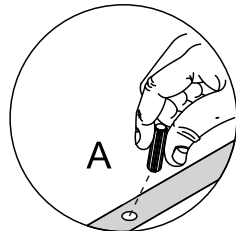
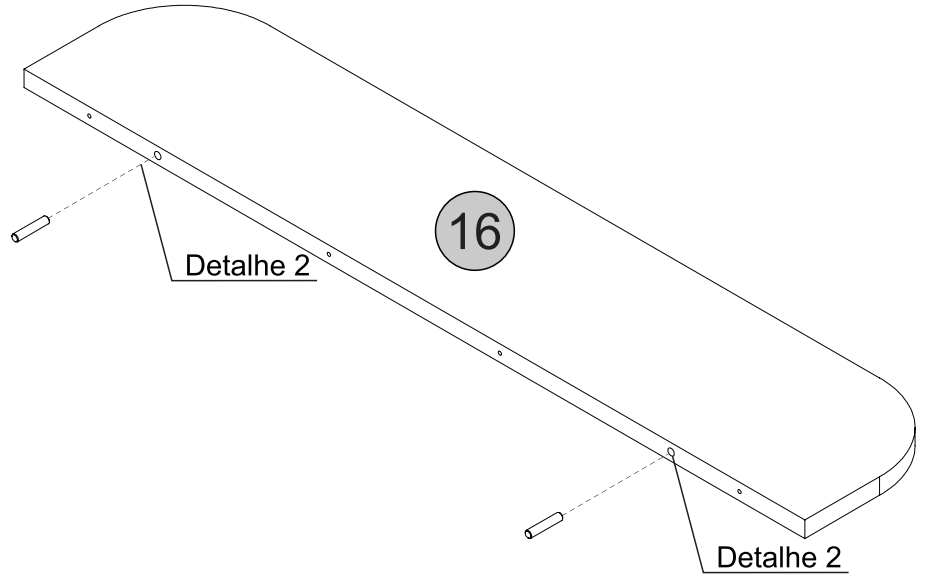
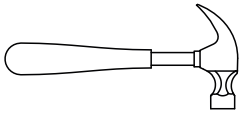

Detalhe 2
Detalle/Detail

Passo 8

Paso/Step

PEÇA

Pieza/Piece

16 - PRATELEIRA SUPERIOR x1

FERRAGEM

Herraje/Hardware

A  02

FERRAMENTA

Herramienta/Tool

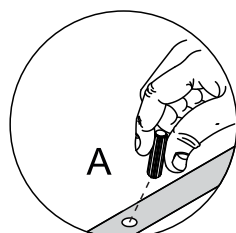
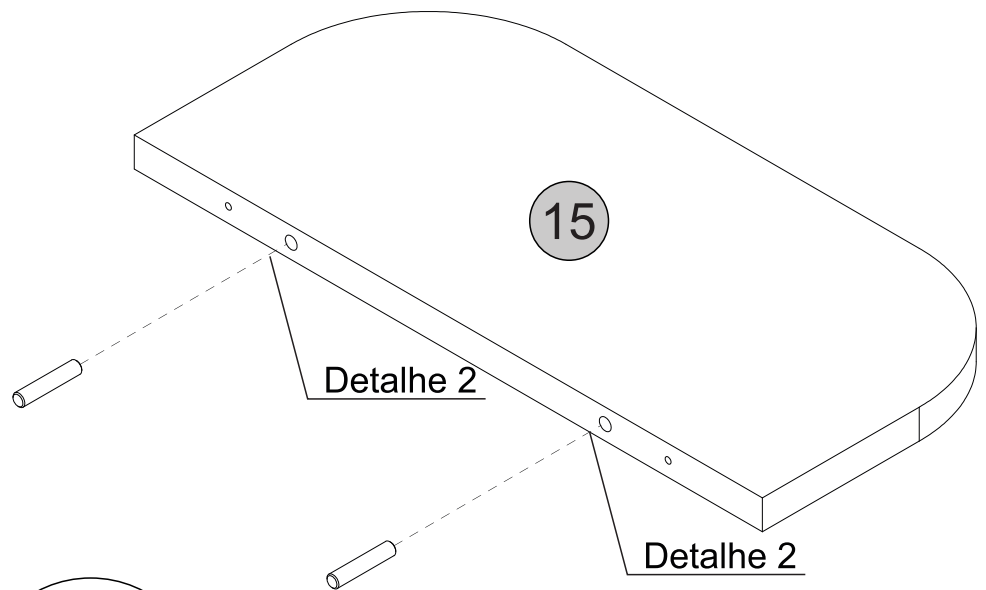
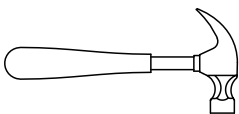

Detalhe 2
Detalle/Detail

Passo 9

Paso/Step

PEÇA
Pieza/Piece

10 - PÉ ESQUERDO x2

11 - PÉ DIREITO x2

FERRAGEM
Herraje/Hardware

B  04

N  04

FERRAMENTA
Herramienta/Tool

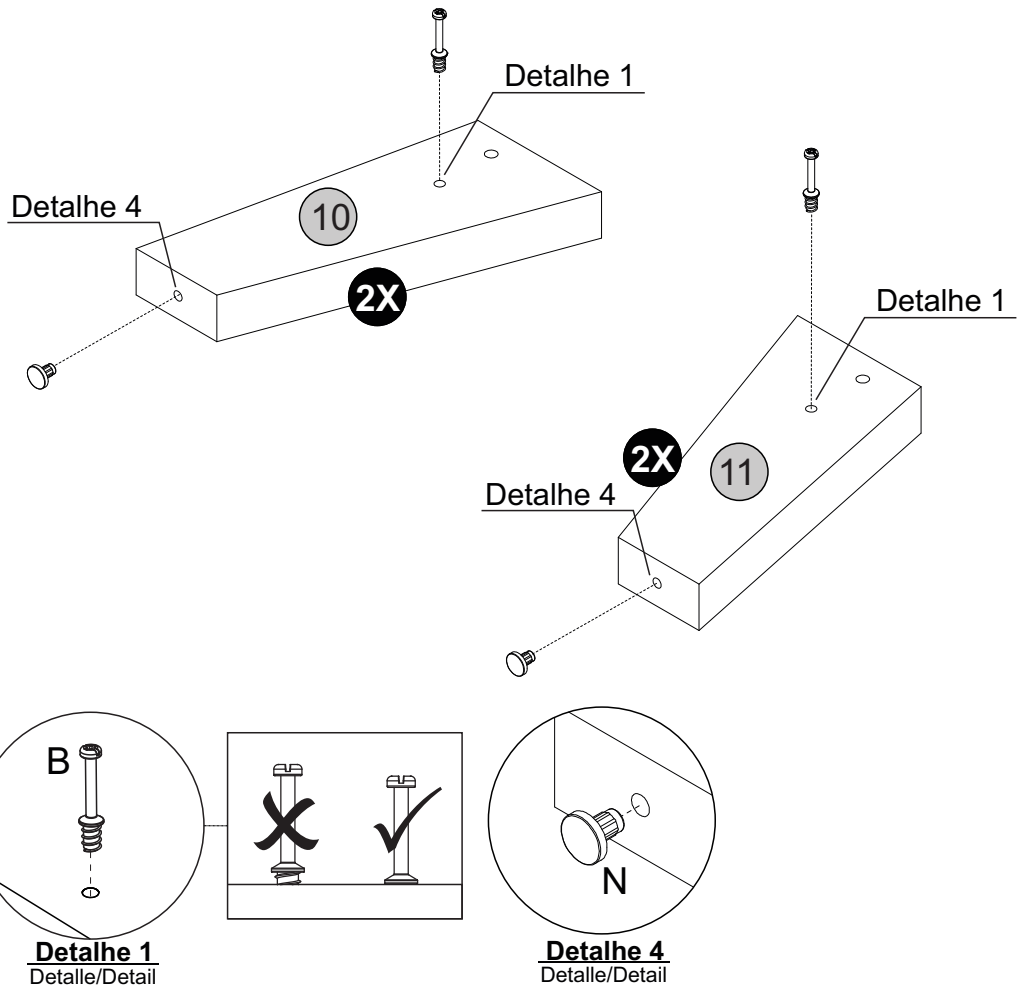
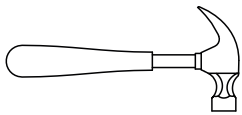
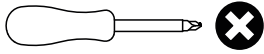

Passo 10

Paso/Step

PEÇA
Pieza/Piece

9 - TRAVESSA DOS PÉS x2

FERRAGEM
Herraje/Hardware

A  04

FERRAMENTA
Herramienta/Tool

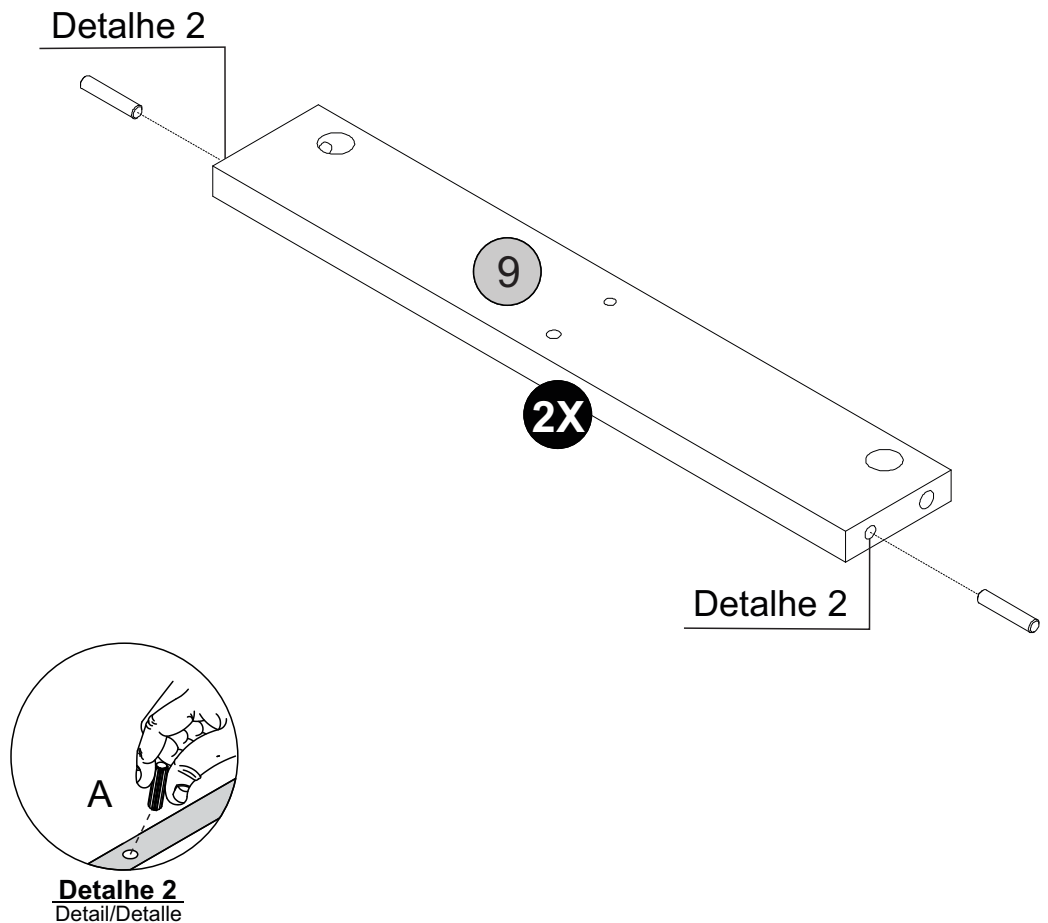
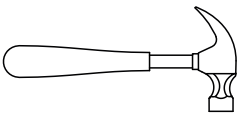

Passo 11

Paso/Step

PEÇA
Pieza/Piece

12 - TRAVESSA BASE x1

FERRAGEM
Herraje/Hardware

A  02

FERRAMENTA
Herramienta/Tool

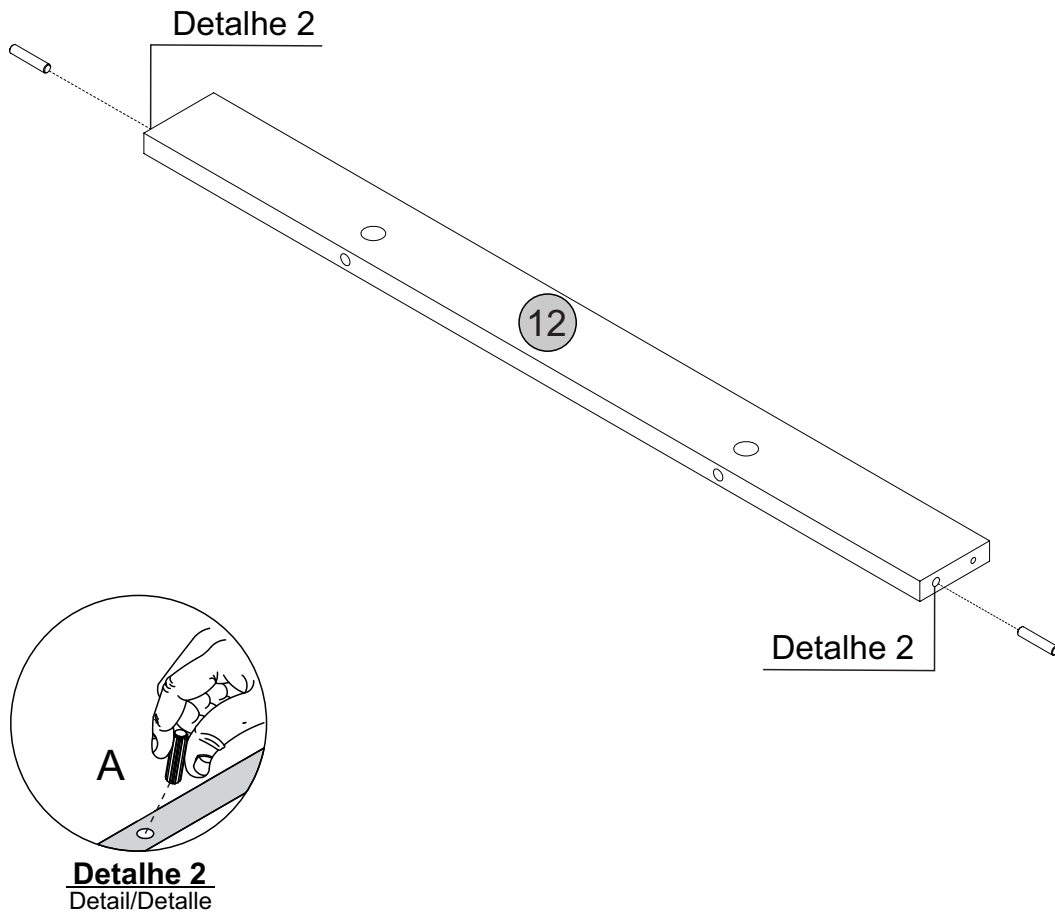
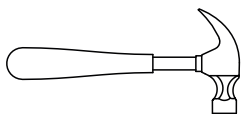

Passo 12

Paso/Step

PEÇA
Pieza/Piece

06 - TRAVESSA PORTA x1

FERRAGEM
Herraje/Hardware

Q  02

R  03

E  05

FERRAMENTA
Herramienta/Tool

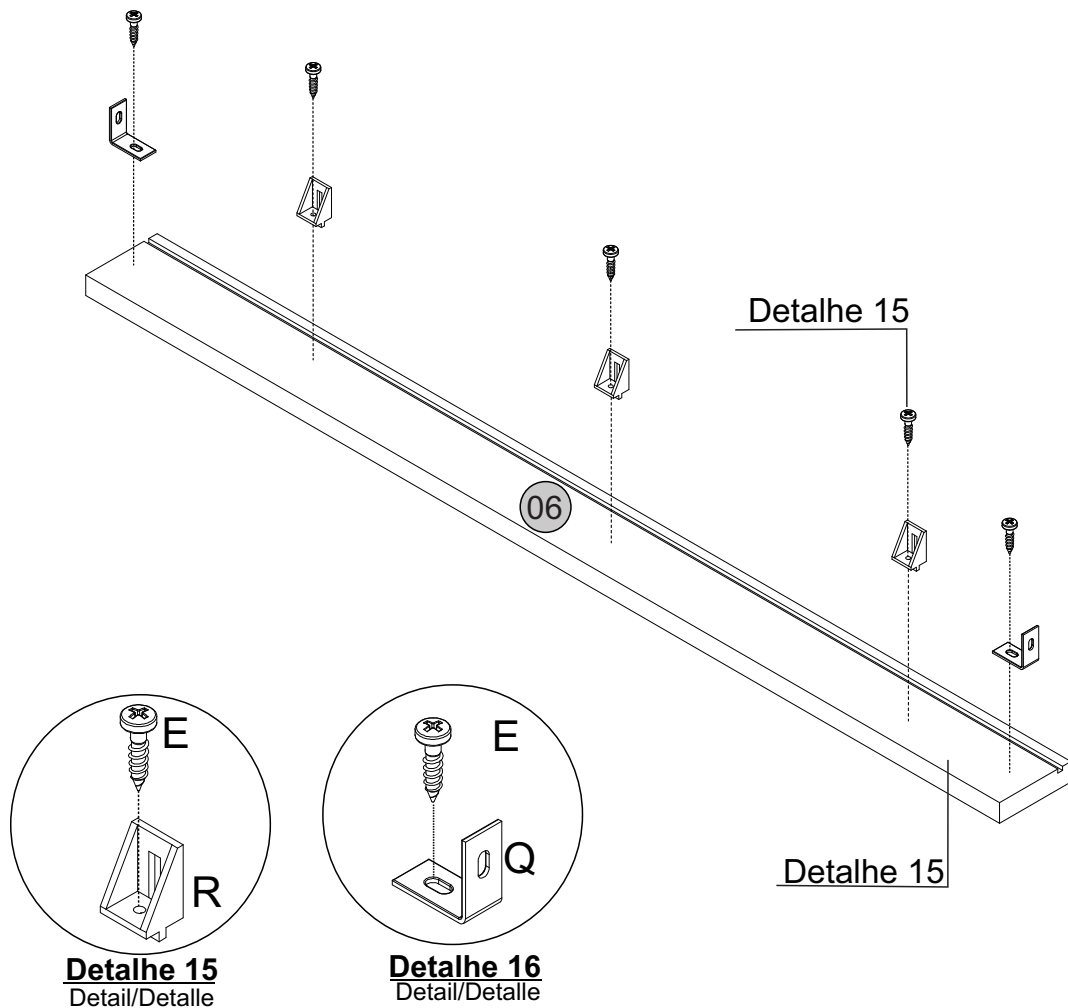
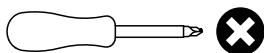

Passo 13

Paso/Step

PEÇA
Pieza/Piece

14 - PORTA ESQUERDA x1

FERRAGEM
Herraje/Hardware

E  04

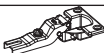
L  02

FERRAMENTA
Herramienta/Tool

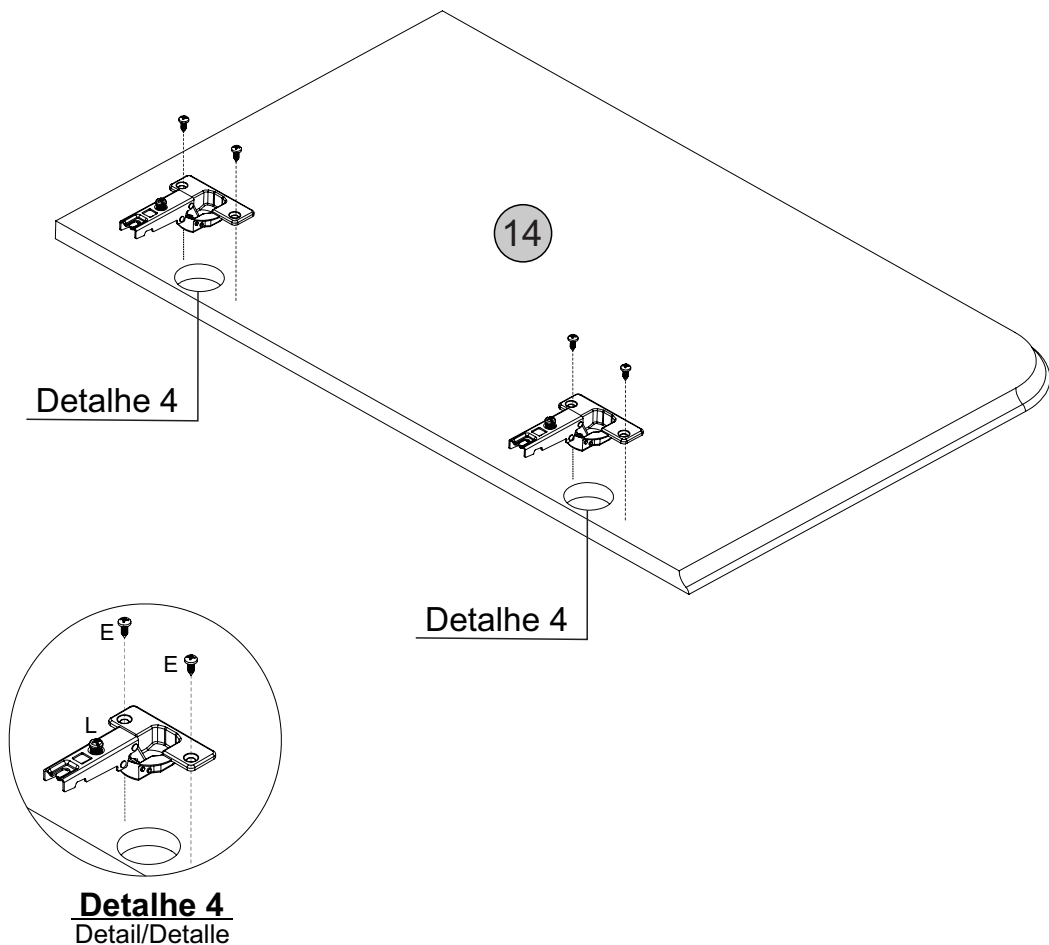
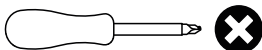

Passo 14

Paso/Step

PEÇA
Pieza/Piece

13 - PORTA DIREITA x1

FERRAGEM
Herraje/Hardware

E  04

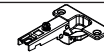
L  02

FERRAMENTA
Herramienta/Tool

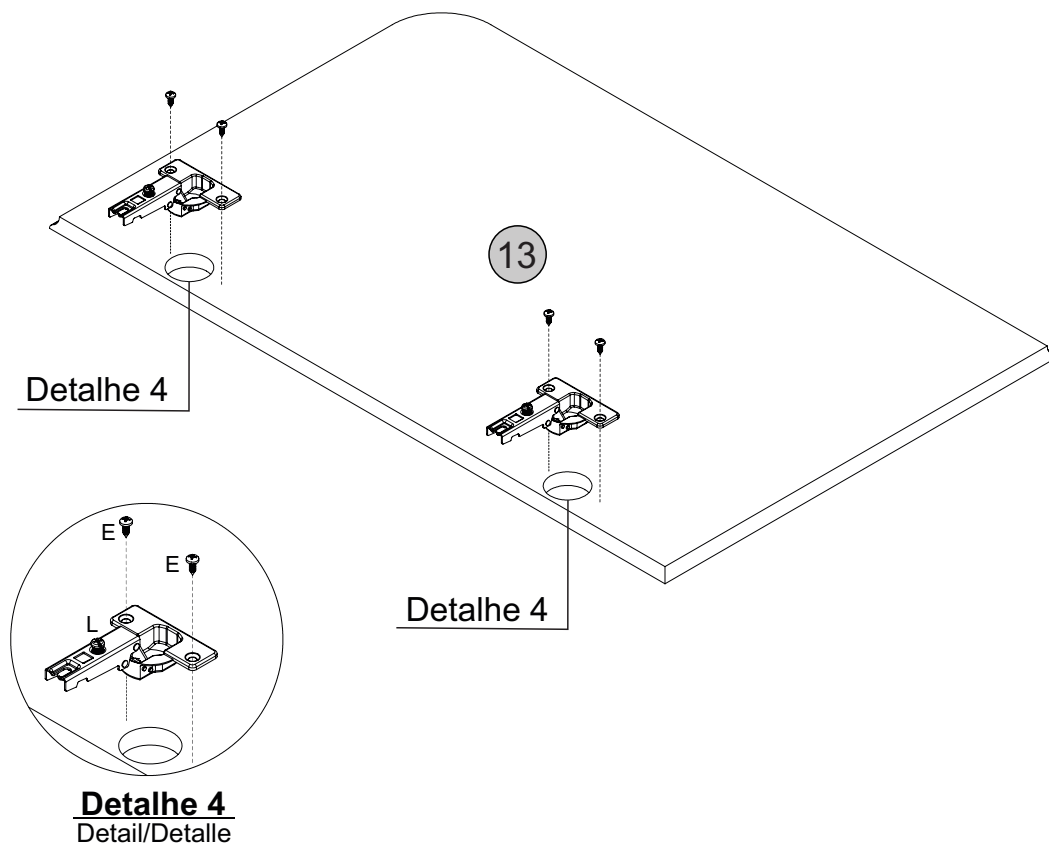
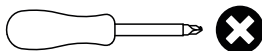

Passo 15

Paso/Step

PEÇA
Pieza/Piece

9 - TRAVESSA DOS PÉS x2

12 - TRAVESSA BASE x1

FERRAGEM
Herraje/Hardware

D  x2

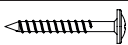
I  x2

FERRAMENTA
Herramienta/Tool

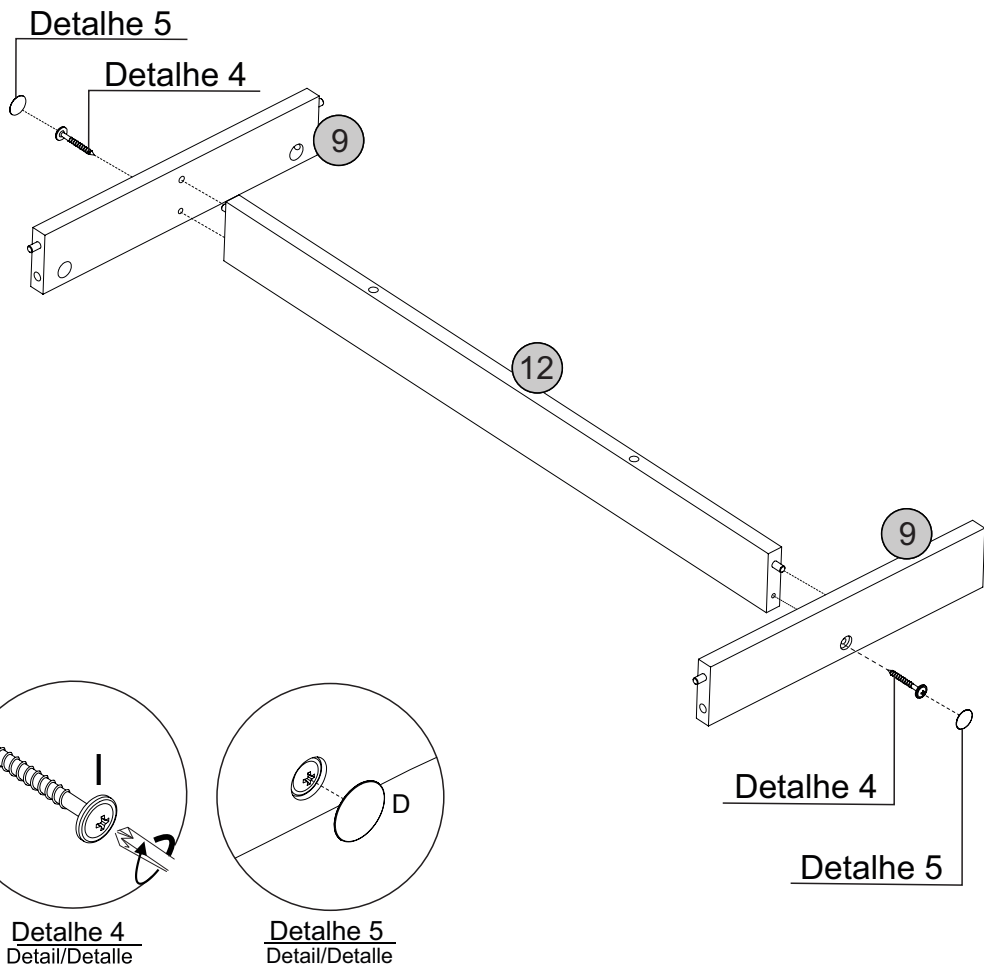
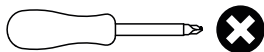

Passo 16

Paso/Step

PEÇA
Pieza/Piece

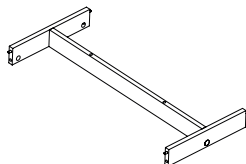

10 - PÉ ESQUERDO x2

11 - PÉ DIREITO x2

FERRAGEM
Herraje/Hardware

C   x4

D  x4

FERRAMENTA
Herramienta/Tool

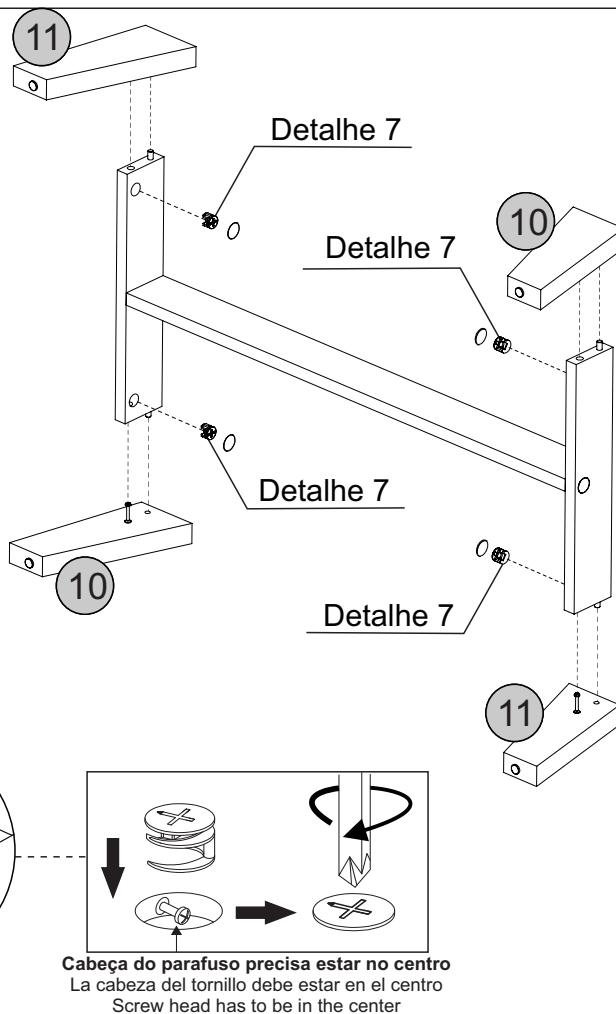
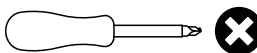

Detalhe 7
Detalle/Detail

Cabeça do parafuso precisa estar no centro
La cabeza del tornillo debe estar en el centro
Screw head has to be in the center

Passo 17

Paso/Step

PEÇA
Pieza/Piece

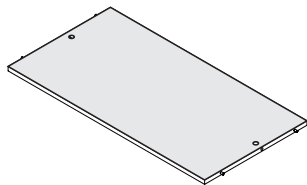

4 - LATERAL ESQUERDA x1

FERRAGEM
Herraje/Hardware

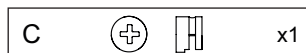

FERRAMENTA
Herramienta/Tool

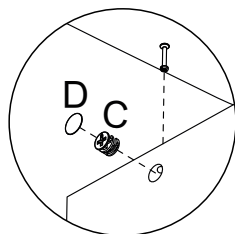
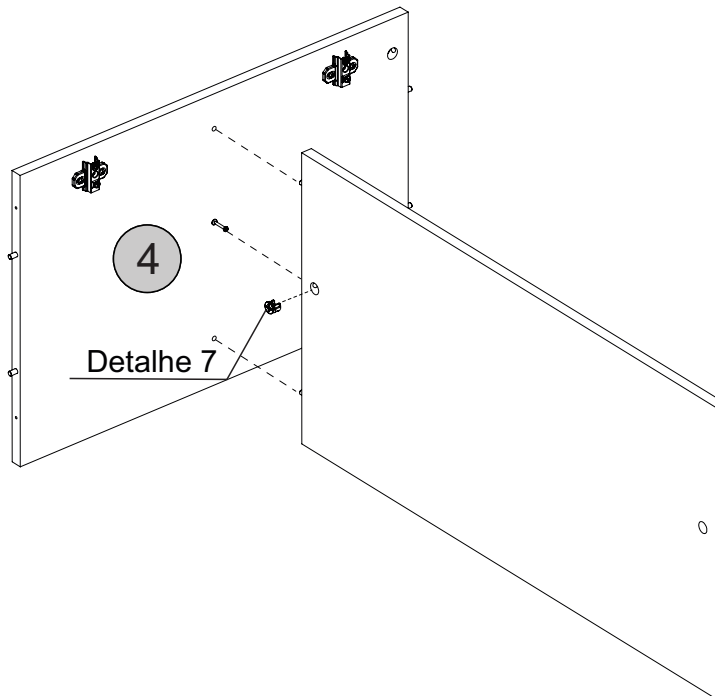
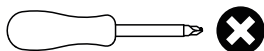

Detalhe 7
Detalle/Detail

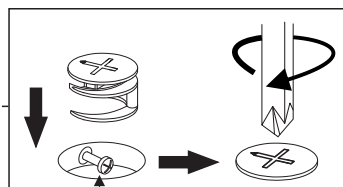

Cabeça do parafuso precisa estar no centro
La cabeza del tornillo debe estar en el centro
Screw head has to be in the center

Passo 18

Paso/Step

PEÇA
Pieza/Piece

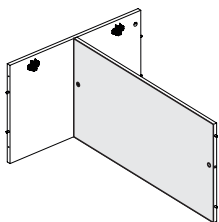

5 - LATERAL DIREITA x1

FERRAGEM
Herraje/Hardware

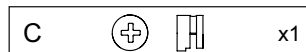

FERRAMENTA
Herramienta/Tool

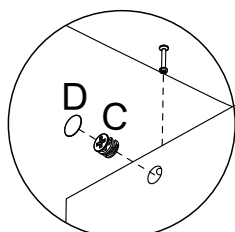
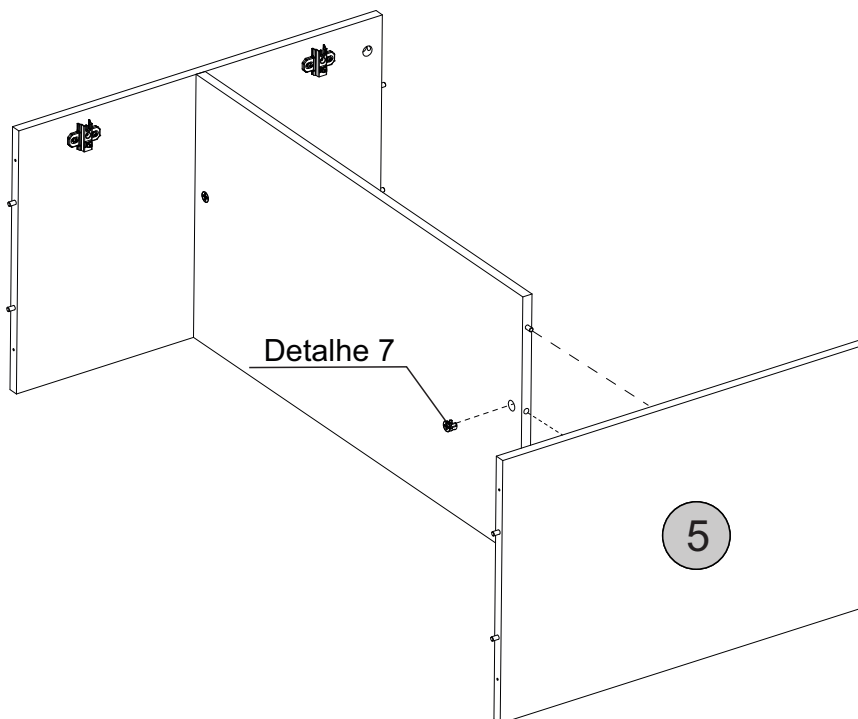
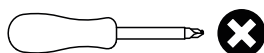

Detalhe 7
Detalle/Detail

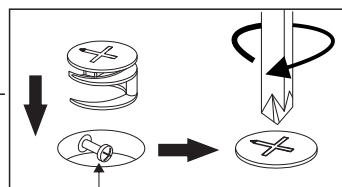

Cabeça do parafuso precisa estar no centro
La cabeza del tornillo debe estar en el centro
Screw head has to be in the center

Passo 19

Paso/Step

PEÇA
Pieza/Piece

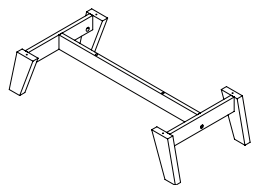

2-BASE

x1

FERRAGEM
Herraje/Hardware

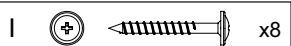

FERRAMENTA
Herramienta/Tool

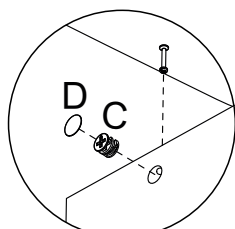
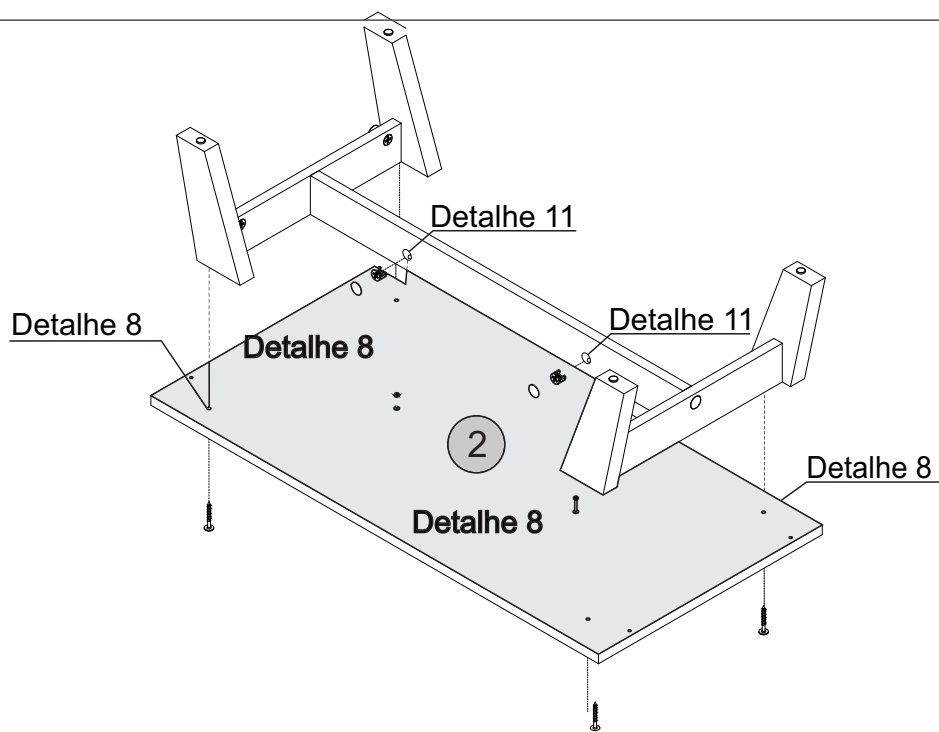
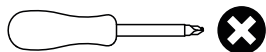

Detalhe 7
Detalle/Detail

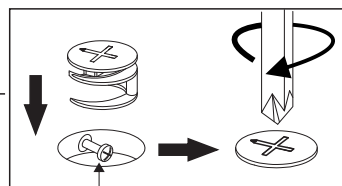

Cabeça do parafuso precisa estar no centro
La cabeza del tornillo debe estar en el centro
Screw head has to be in the center

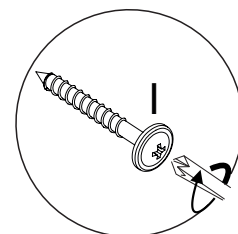

Detalhe 8
Detail/Detalle

Passo 20

Paso/Step

PEÇA
Pieza/Piece

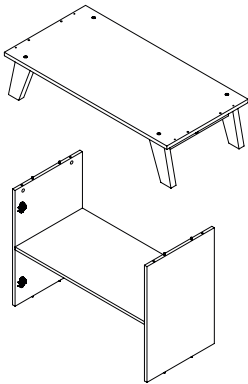

FERRAGEM
Herraje/Hardware



FERRAMENTA
Herramienta/Tool

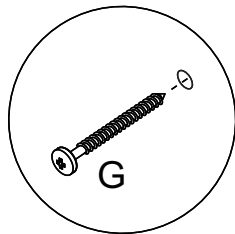
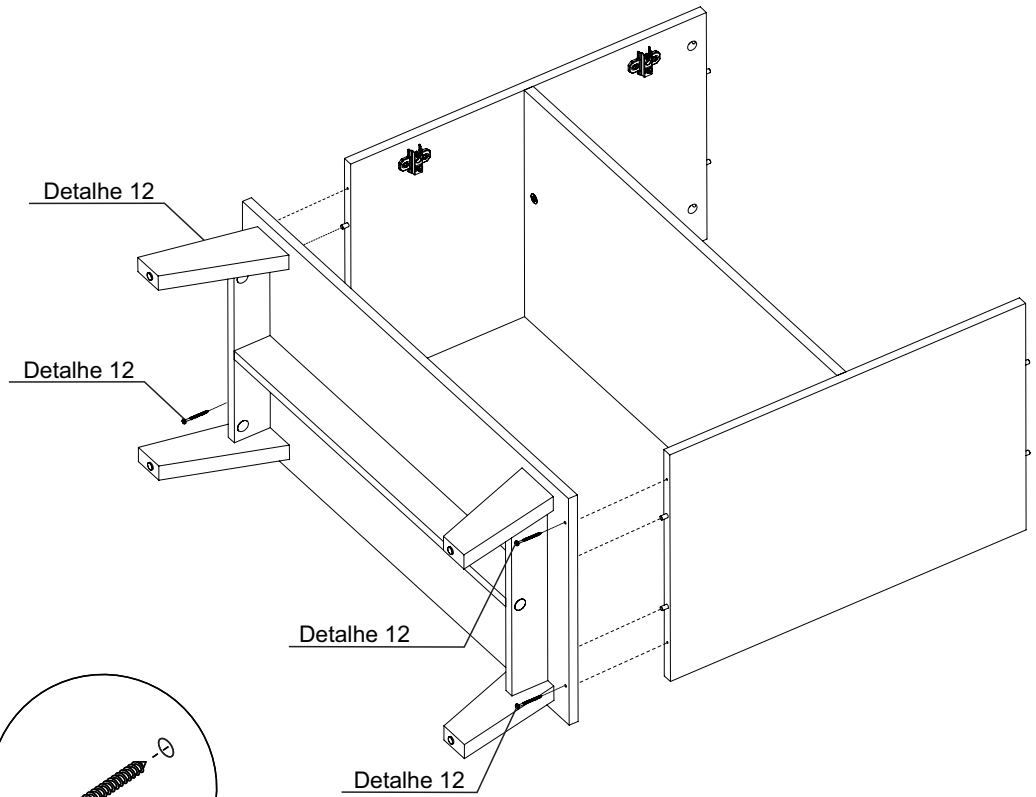
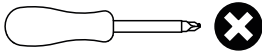

Detalhe 12
Detalle/Detail

Passo 21

Paso/Step

PEÇA
Pieza/Piece

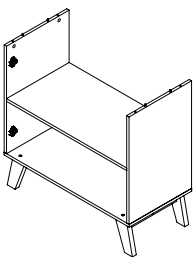

1 - TAMPO x1

FERRAGEM
Herraje/Hardware

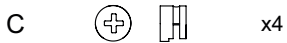

x4



x4

FERRAMENTA
Herramienta/Tool

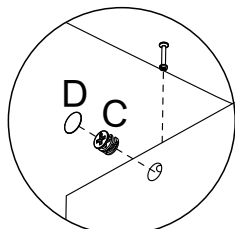
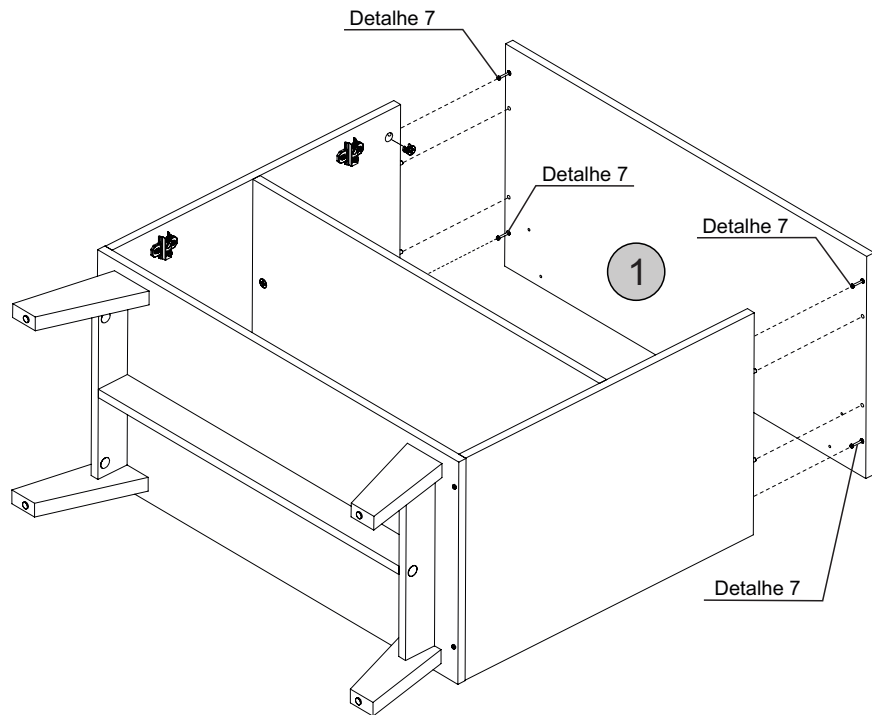
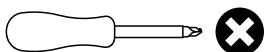

Detalhe 7
Detalle/Detail

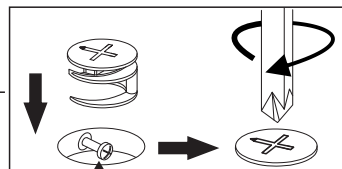

Cabeça do parafuso precisa estar no centro
La cabeza del tornillo debe estar en el centro
Screw head has to be in the center

Passo 22

Paso/Step

PEÇA

Pieza/Piece

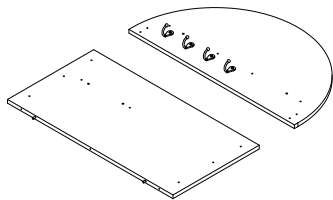

19 - TRAVESSA TRASEIRO x1

FERRAGEM

Herraje/Hardware

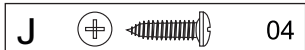

FERRAMENTA

Herramienta/Tool

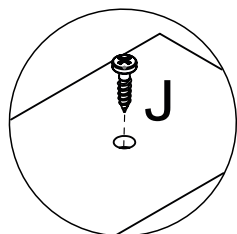
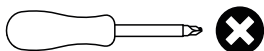

Detalhe 7
Detail/Detalle

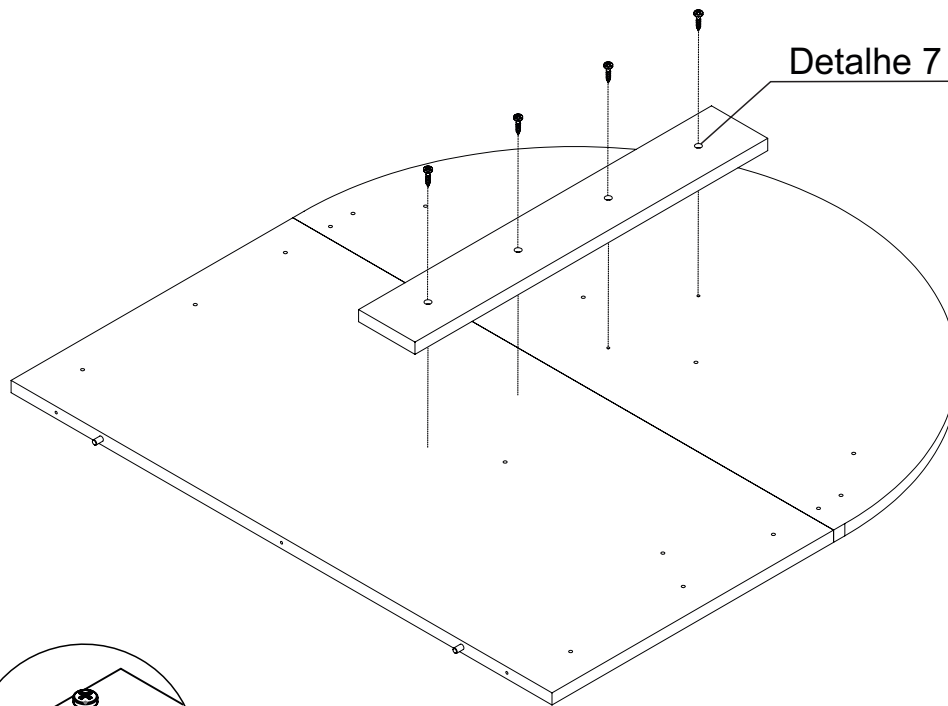

Passo 23

Paso/Step

PEÇA

Pieza/Piece

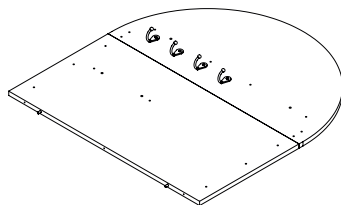

17 - TRAVESSA x1

FERRAGEM

Herraje/Hardware



FERRAMENTA

Herramienta/Tool

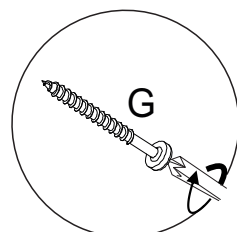
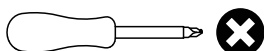

Detalhe 12
Detail/Detalle

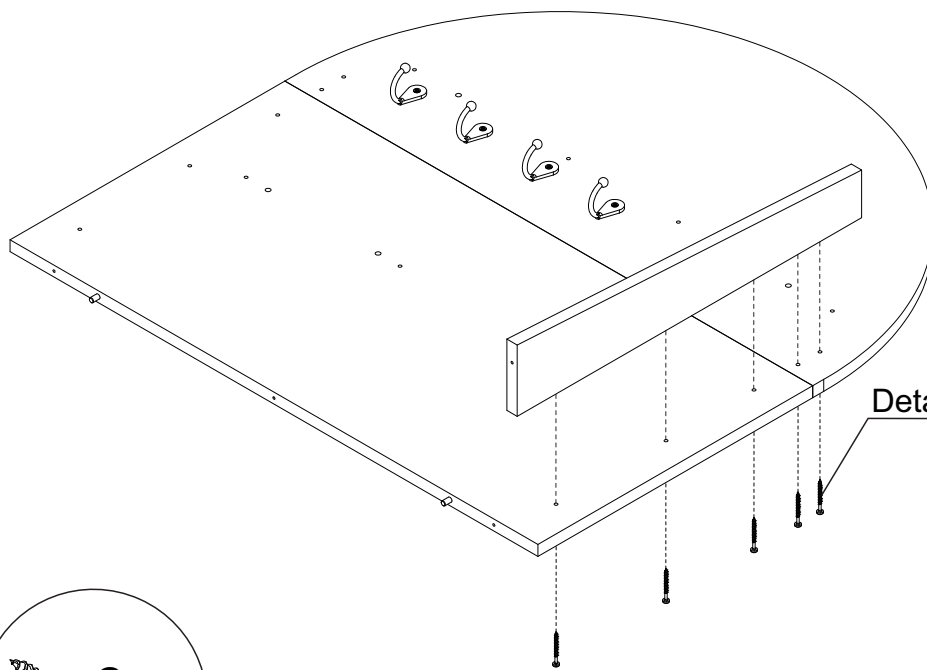

Detalhe 12

Passo 24

Paso/Step

PEÇA

Pieza/Piece

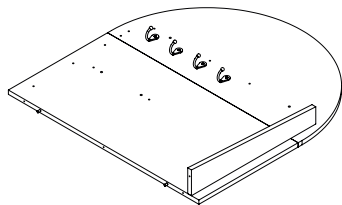

17 - TRAVESSA x1

FERRAGEM

Herraje/Hardware

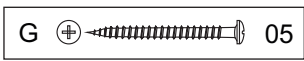

FERRAMENTA

Herramienta/Tool

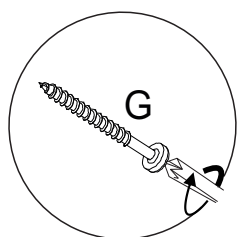
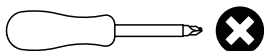

Detalhe 12
Detail/Detalle

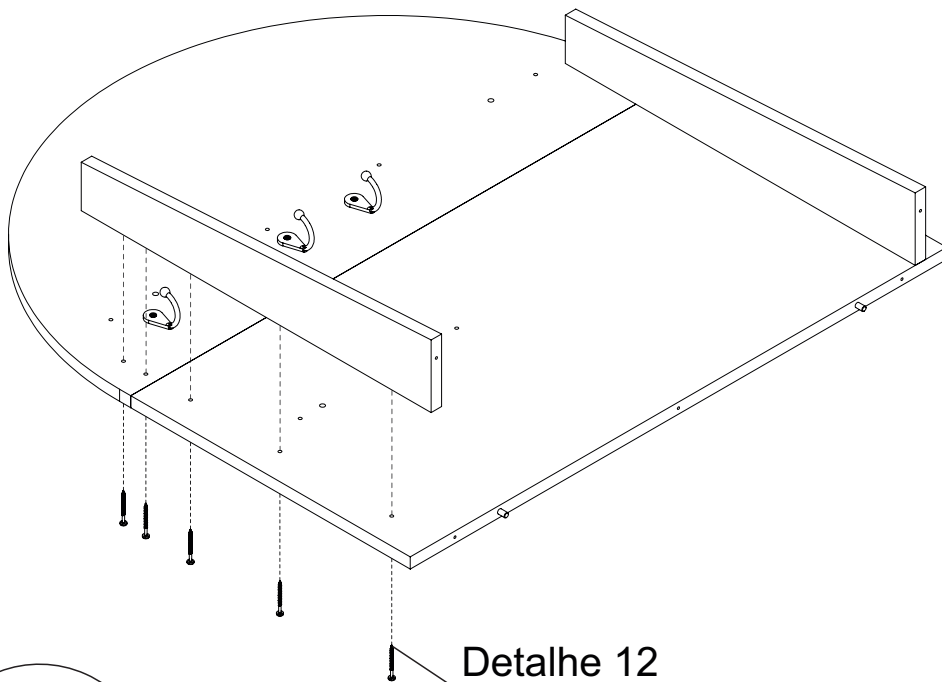

Passo 25

Paso/Step

PEÇA

Pieza/Piece

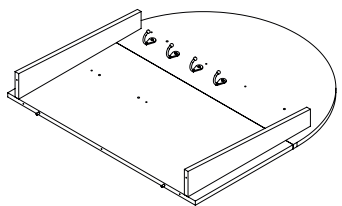

15 - PRATELEIRA MENOR x1

FERRAGEM

Herraje/Hardware

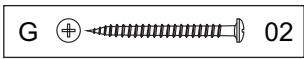

FERRAMENTA

Herramienta/Tool

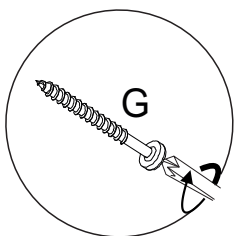
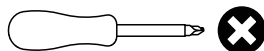

Detalhe 12
Detail/Detalle

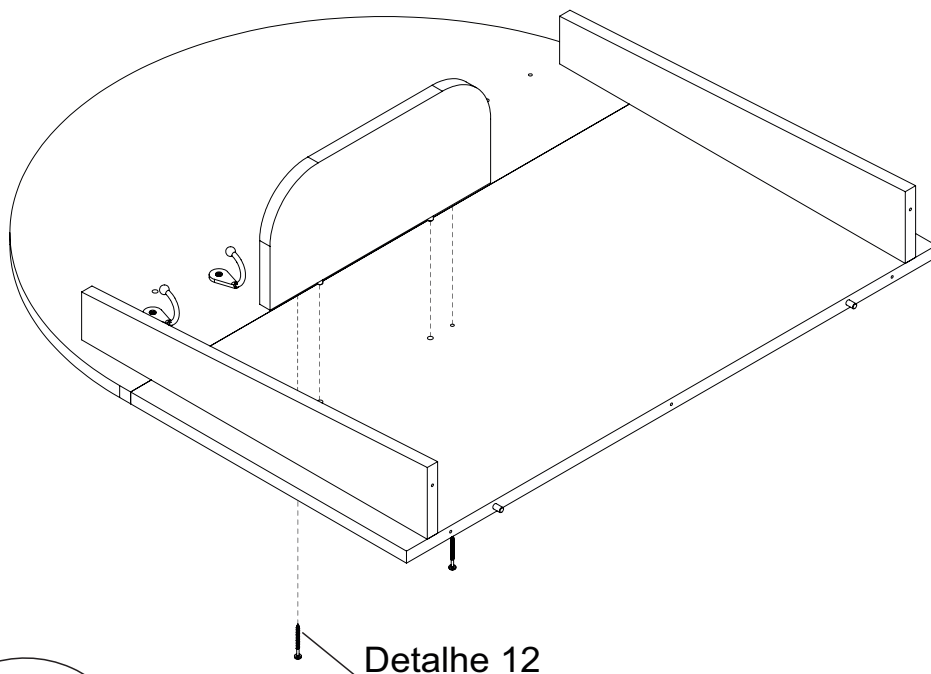

Passo 26

Paso/Step

PEÇA

Pieza/Piece

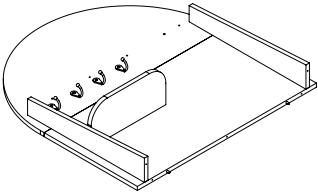

16 - PRATELEIRA SUPERIOR x1

FERRAGEM

Herraje/Hardware

G  04

FERRAMENTA

Herramienta/Tool

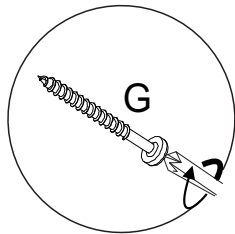
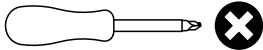

Detalhe 12
Detail/Detaille

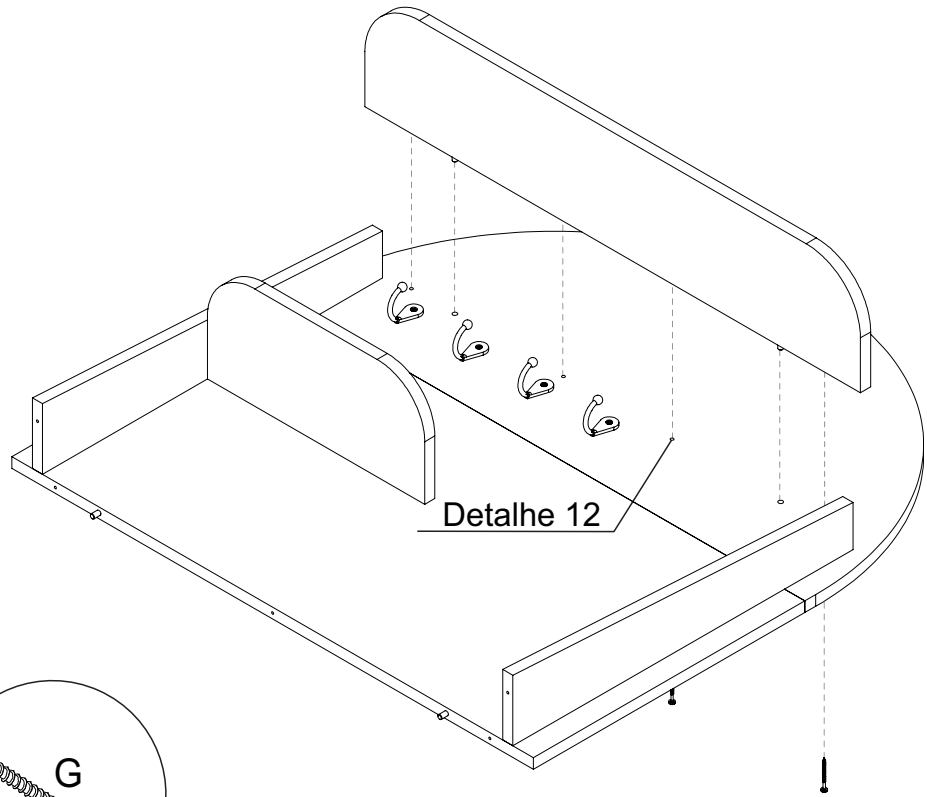

Passo 27

Paso/Step

PEÇA

Pieza/Piece

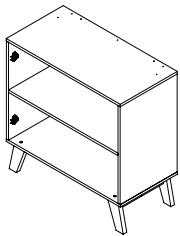
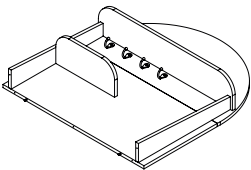

FERRAGEM

Herraje/Hardware

G  05

FERRAMENTA

Herramienta/Tool

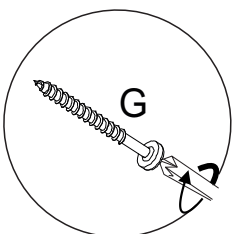
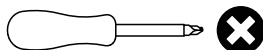

Detalhe 12
Detail/Detaille

Detalhe 12

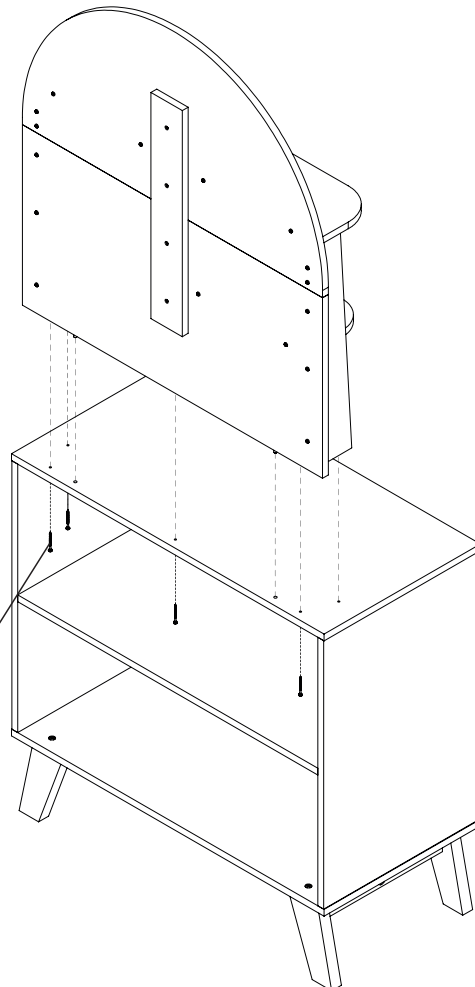

Passo 28

Paso/Step

PEÇA
Pieza/Piece

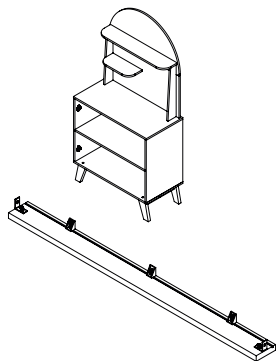

FERRAGEM
Herraje/Hardware

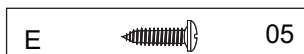

FERRAMENTA
Herramienta/Tool

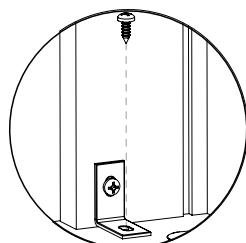
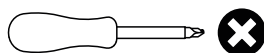

Detalhe 18
Detail/Detalle

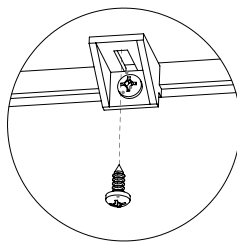

Detalhe 19
Detail/Detalle

Detalhe 19

Detalhe 18

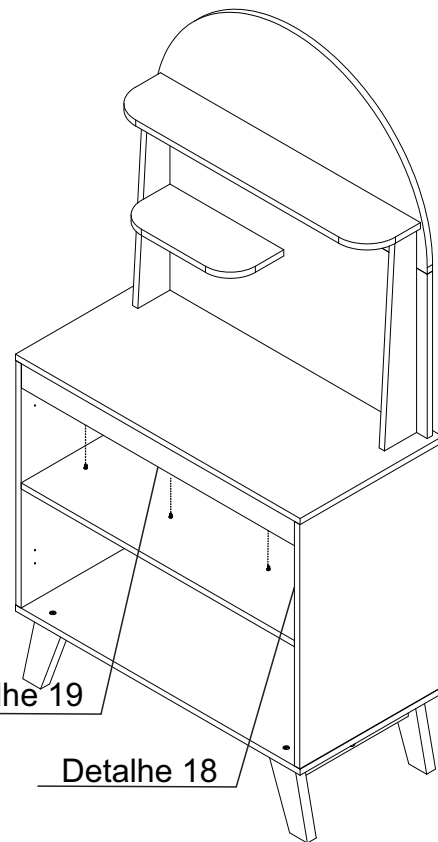

Passo 29

Paso/Step

PEÇA
Pieza/Piece

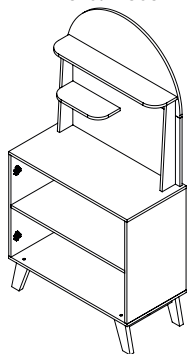

13 - PORTA DIREITA x2

14 - PORTA ESQUERDA x2

FERRAMENTA
Herramienta/Tool

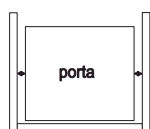
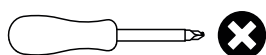

Ajuste de Largura

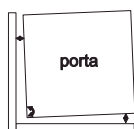

Ajuste Interno



Ajuste de Profundidade

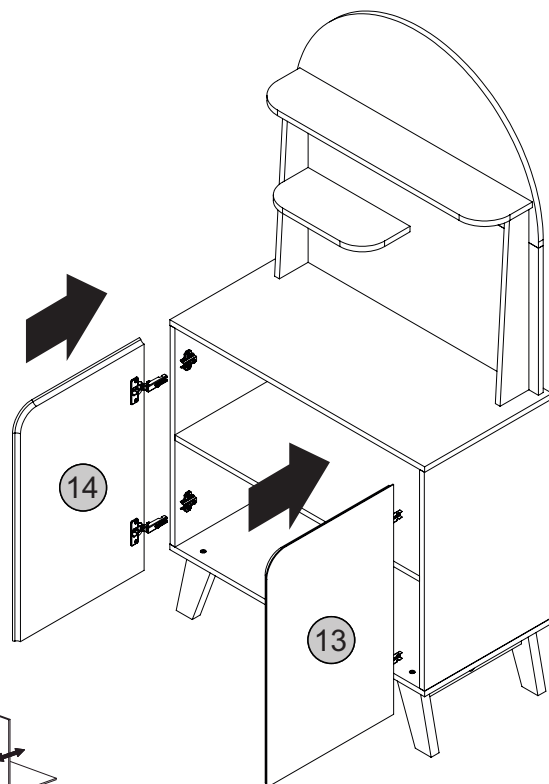
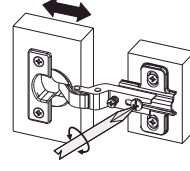
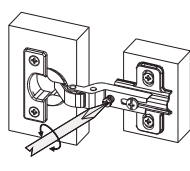
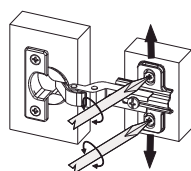

Passo 30

Paso/Step

PEÇA
Pieza/Piece

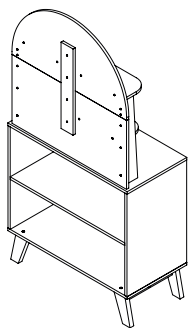

18 - TRASEIRO

x2

FERRAGEM
Hardware/Herraje

O  25

P  05

FERRAMENTA
Herramienta/Tool

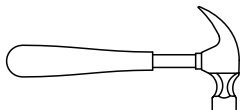

Detalhe 13

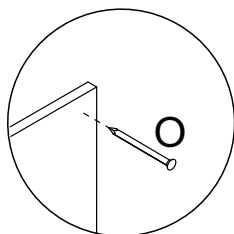

Detalhe 13
Detail/Detalle

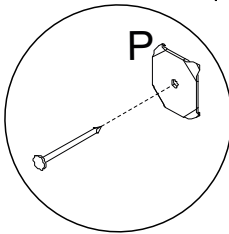

Detalhe 14
Detail/Detalle

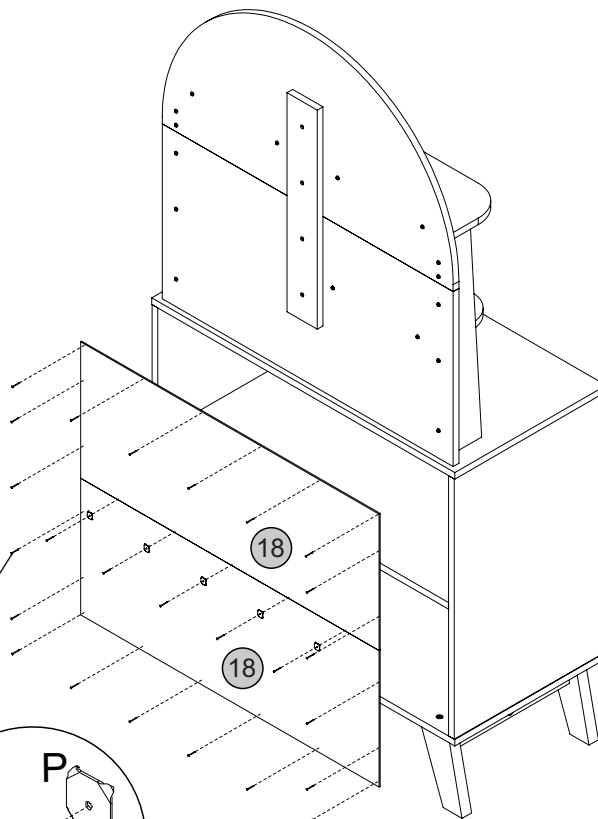

Passo 31

Paso/Step

