



**JCM**  
m o v e l a r i a

# Buffet Harmonia Harmonia Sideboard Bufetera Harmonia



Indicamos que a montagem dos produtos seja realizada com parafusadeira eléctrica e por um montador profissional.  
**We recommend that a professional furniture assembler assemble the product by using a cordless screwdriver.**  
Se recomienda que un montador de muebles profesional realice el montaje del producto con un destornillador eléctrico.

AVISO: Não nos comprometemos pelo mal-uso, montagem e fixação do produto à parede. Portanto, não somos responsáveis por danos e quedas do produto, eletrônicos e pertences neles contidos. É importante o uso de brocas e ferramentas compatíveis na montagem.  
NOTICE: The company is not responsible for the misuse, assembly, and wall fixation, as well as the damages and falls that the products, electronics, and belongings therein might suffer. It is important to use suitable drills and tools to assemble the product.  
ATENCIÓN: La empresa no se responsabiliza del mal uso, montaje y fijación del producto a la pared, así como de daños y caídas del producto, electrónicos u objetos. Es importante el uso de taladros y herramientas compatibles con el montaje.

Dica: para evitar possíveis avarias, use a embalagem do produto como apoio durante a montagem.  
**Tip: to avoid damages, use the product packaging as a base during the assembly.**  
Pista: para evitar daños, use el envase del producto como apoyo durante el montaje.

## RELAÇÃO DE FERRAGENS | HARDWARE LIST | LISTADO DE HERRAJES

BATENTE 2 FUROS	(A)	2-HOLES STOP	(A)	DETENDER 2 AGUJEROS	(A)		01
CALÇO DOBRADIÇA 12mm	(B)	12mm HINGE MOUNTING PLATE	(B)	BASE DE BISAGRA 12mm	(B)		04
CALÇO DOBRADIÇA 5mm	(C)	5mm HINGE MOUNTING PLATE	(C)	BASE DE BISAGRA 5mm	(C)		02
CANTONEIRA 04 FUROS	(D)	4-HOLE ANGLE BRACKET	(D)	REFUERZO DE ÁNGULO 4 AGUJEROS	(D)		08
DOBRADIÇA ALTA 26mm	(E)	26mm HALF OVERLAY HINGE	(E)	BISAGRA ACODADA 26mm	(E)		06
PARAFUSO 3,5x14	(F)	3.5x14 SCREW	(F)	TORNILLO 3,5x14	(F)		58
PARAFUSO 3,5x30 FLANG.	(G)	3.5x30 FLANGE SCREW	(G)	TORNILLO TIPO FLANGE 3,5x30	(G)		03
PARAFUSO 3,5x35 FLANG.	(H)	3.5x35 FLANGE SCREW	(H)	TORNILLO TIPO FLANGE 3,5x35	(H)		08
PARAFUSO 5x40	(I)	5x40 SCREW	(I)	TORNILLO 5x40	(I)		10
PARAFUSO MINIFIX	(J)	MINIFIX BOLT	(J)	PERNO MINIFIX	(J)		06
PINO SUPORTE PRATELEIRA	(K)	SHELVES SUPPORTS	(K)	SUPORTES ESTANTES	(K)		04
PREGO 8x8 C/C	(L)	8x8 NAIL	(L)	CLAVO 8x8	(L)		30
PUXADOR	(M)	HANDLE	(M)	TIRADOR	(M)		03
TAMBOR MINIFIX	(N)	MINIFIX CAM	(N)	CAJA DEL MINIFIX	(N)		06

RELAÇÃO DE PEÇAS | PARTS LIST | LISTADO DE PARTES

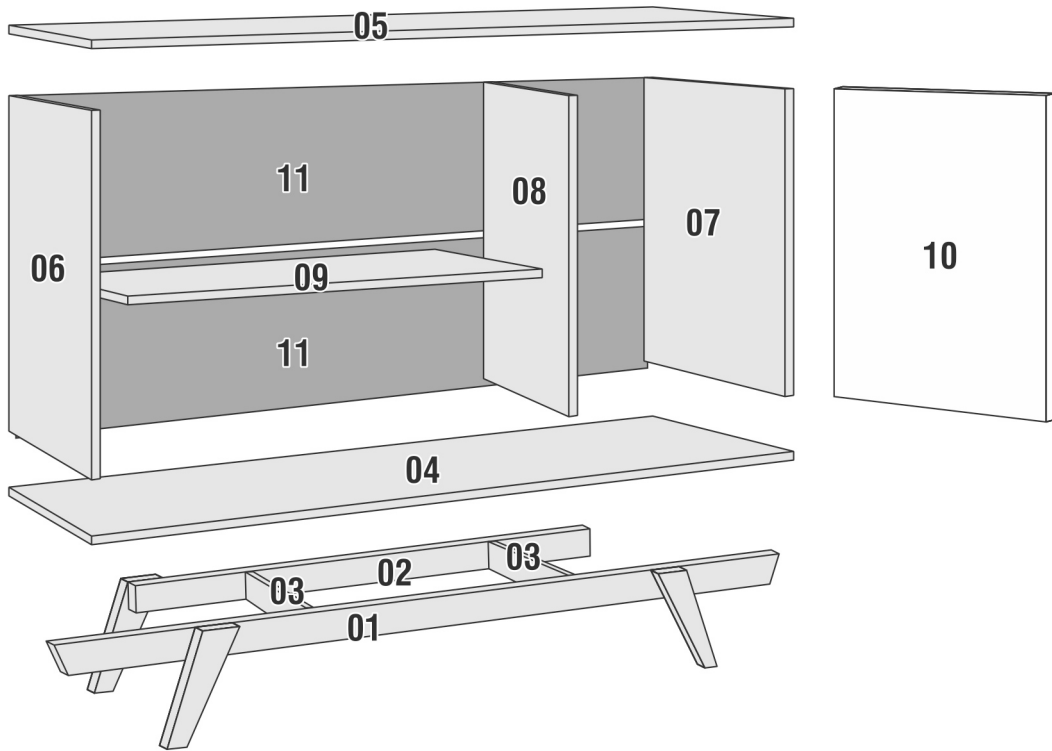

**01** Rodapé Frontal  
Front Toe  
Zócalo Frontal 1Pc



**02** Rodapé Traseiro  
Back Toe  
Zócalo Trasero 1Pc



**03** Rodapé Interno  
Internal Toe  
Zócalo Interno 2Pcs



**04** Base  
Bottom  
Base 1Pc



**05** Tampo  
Top  
Tapa 1Pc



**06** Lateral Esquerda  
Left Side  
Lateral Izquierdo 1Pc



**07** Lateral Direita  
Right Side  
Lateral Derecho 1Pc



**08** Divisão  
Divider  
División 1Pc



**09** Prateleira  
Shelf  
Estante 1Pc



**10** Porta  
Door  
Puerta 3Pcs



**11** Costas  
Back  
Trasero 2Pcs

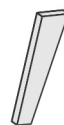

Pé  
Foot  
Pata 4Pcs

Passo 01 IDENTIFIQUE AS PEÇAS JÁ COLOCANDO OS SEUS ACESSÓRIOS. COMECE A MONTAGEM PELA PEÇA 5. ENCAIXE AS PEÇAS 6, 7 E 8 NA PEÇA 5 COM MINIFIX (J+N) E PARAFUSE O BATENTE 2 FUROS(A+F).

**Step 01 IDENTIFY THE PARTS AND FASTEN THEIR HARDWARE. START THE ASSEMBLY BY PART 5. FASTEN PARTS 7, 8, AND 11 TO PART 5 WITH MINIFIX(J+N) AND FASTEN STOP 2 HOLES(A+F).**

**Paso 01 IDENTIFIQUE LAS PARTES Y FIJE SUS HERRAJES. EMPIECE EL MONTAJE POR LA PARTE 5. FIJE LAS PARTES 7, 8 Y 11 A LA PARTE 5 CON MINIFIX(J+N) Y FIJE O DETENTER 2 AGUJEROS (A+F).**

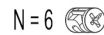
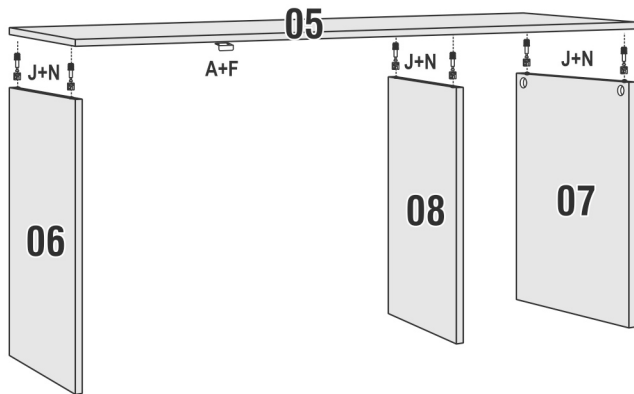

Passo 02 PARAFUSE A PEÇA 4 NAS PEÇAS 6, 7 E 8 COM PARAFUSO 5x40(I).

**Step 02 FASTEN PART 4 TO PARTS 6, 7, AND 8 WITH 5x40 SCREW (I).**

**Paso 02 FIJE LA PARTE 4 A LAS PARTES 6, 7 Y 8 CON TORNILLO 5x40 (I).**

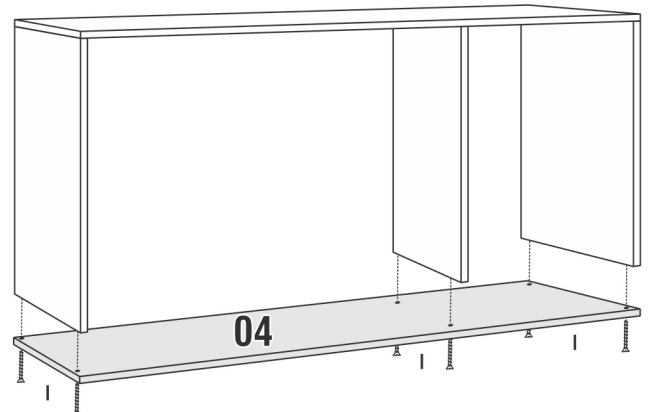

Passo 04 PARAFUSE OS PÉS NA PEÇA 4 COM PARAFUSO 5x40(I) E CANTONEIRA 4 FUROS(D+F).

**Step 04 FASTEN THE FEET TO PART 4 WITH 5x40 SCREW(I) AND 4-HOLE ANGLE BRACKET(D+F).**

**Paso 04 FIJE LAS PATAS A LA PARTE 4 CON TORNILLO 5x40(I) Y REFUERZO DE ÁNGULO 4 AGUJEROS(D+F).**

Passo 03 PARAFUSE OS PÉS NA PEÇA 4 COM PARAFUSO 5x40(I).

**Step 03 FASTEN THE FEET TO PART 4 WITH 5x40 SCREW(I).**

**Paso 03 FIJE LAS PATAS A LA PARTE 4 CON TORNILLO 5x40(I).**

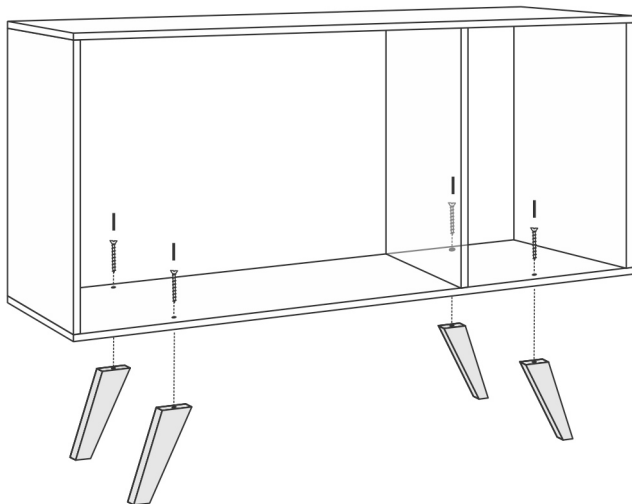

Passo 03 FAÇA A MONTAGEM DOS PÉS CONFORME A IMAGEM COM AS RESPECTIVAS FERRAGENS.

**Step 03 AS THE PICTURE SHOWS, USE THE HARDWARE TO FASTEN THE FEET.**

**Paso 03 UTILICE LOS HERRAJES PARA FIJAR LAS PARTES SEGÚN EL DISEÑO.**

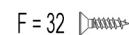
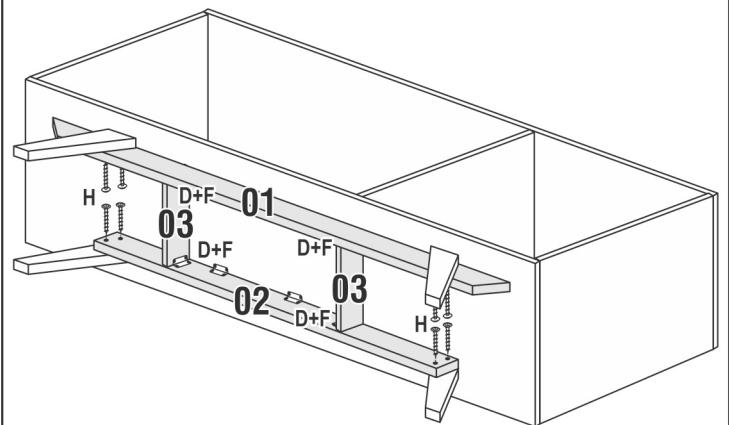

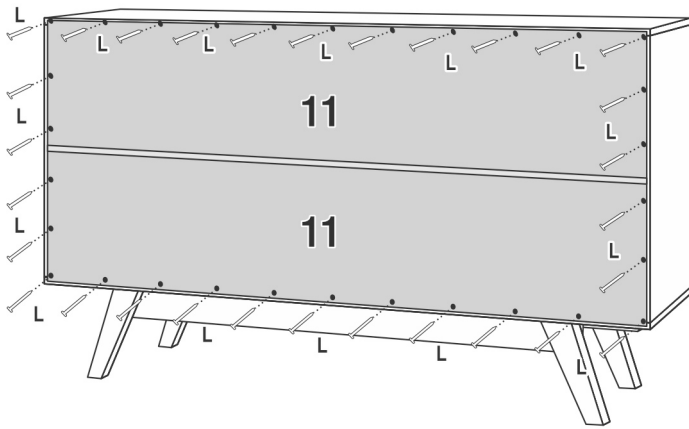

Passo 04 PREGUE AS COSTAS COM PREGO 8x8 C/C (L).  
**Step 04 FASTEN THE BACK PANELS WITH 8x8 NAILS (L).**  
 Paso 04 FIJE LOS PANELES TRASEROS CON CLAVOS 8x8 (L).



L = 30 

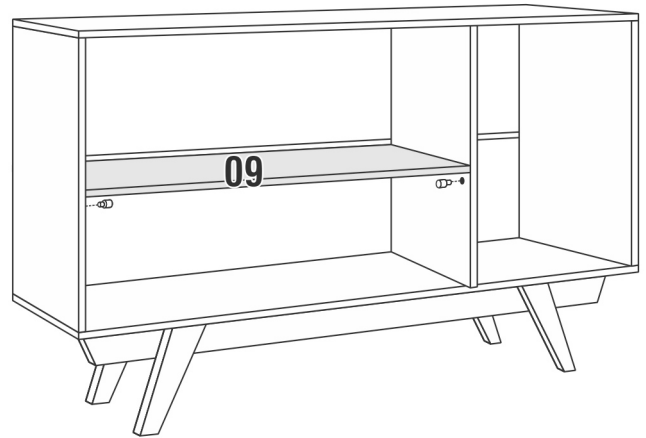



Passo 06 MONTE AS PRATELEIRAS 10 COM PINO SUPORTE (K).  
**Step 06 THEN FASTEN THE SHELVES 10 WITH THE SHLEVES SUPPORTS (K).**  
 Paso 06 MONTE LOS ESTANTES 10 CON SOPORTES DE ESTANTES (K).

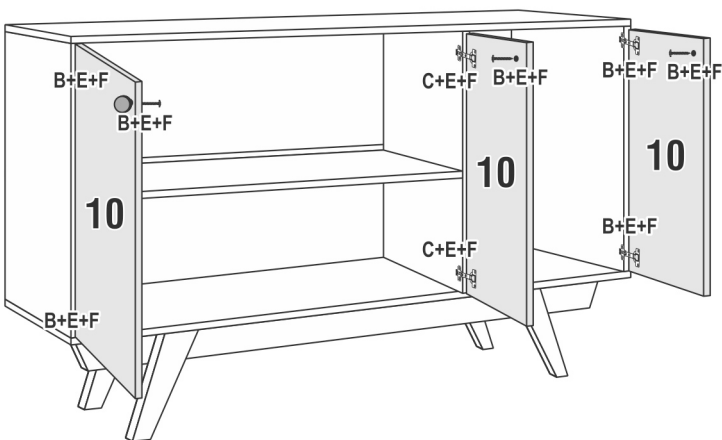

K = 04 

Passo 07 MONTE E FIXE AS PORTAS 10 NAS PEÇAS 6, 7 E 8 COM AS RESPECTIVAS FERRAGENS.  
**Step 07 USE THE HARDWARE TO ASSEMBLE THE DOORS 10 AND ATTACH THEM TO PARTS 6, 7, AND 8.**  
 Paso 07 UTILICE LOS HERRAJES PARA MONTAR LAS PUERTAS 10 Y FÍJELAS A LAS PARTES 6, 7 Y 8.



B = 4  C = 2  E = 6  F = 24 

G = 3  M = 3 

Passo 08 PRODUTO MONTADO.  
**Step 08 PRODUCT ASSEMBLED.**  
 Paso 08 PRODUCTO MONTADO.

