

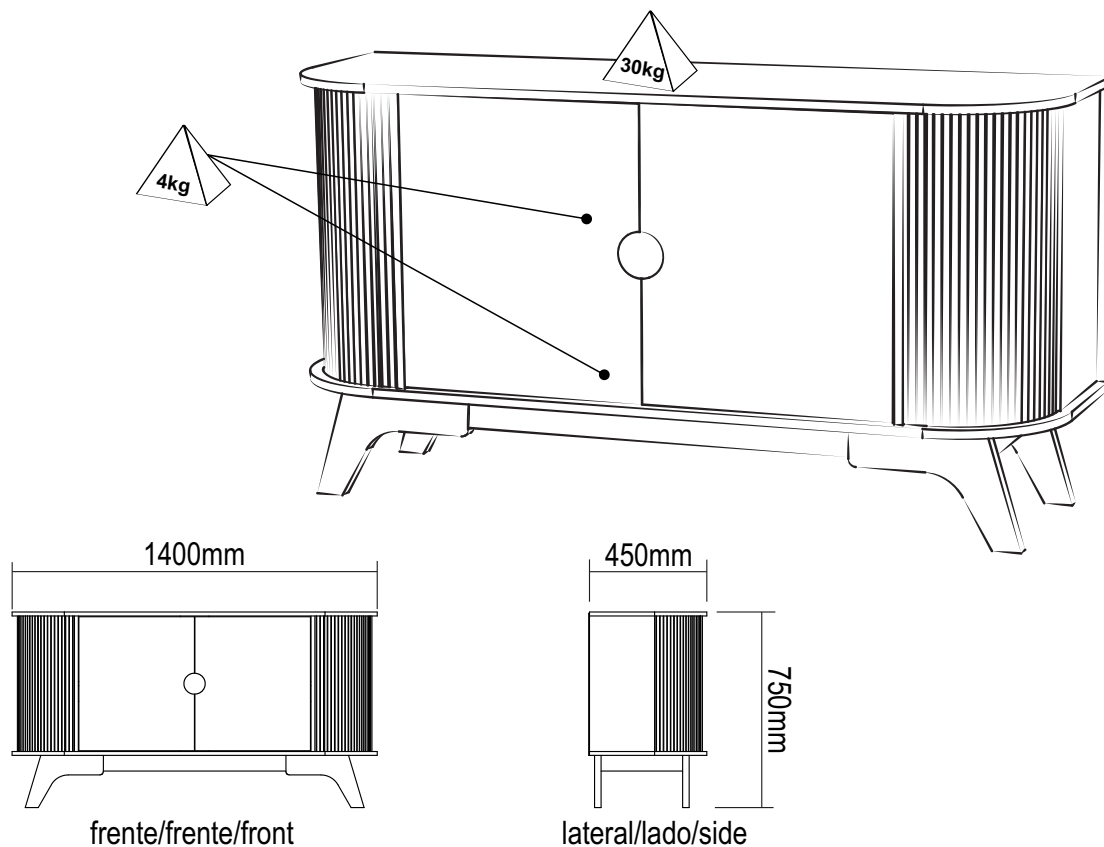

Buffet Vivaldi

Buffet Vivaldi / Vivaldi Buffet

Versão 1.0 / Versión 1.0 / Version 1.0



Conservação e Limpeza - Conservación y Limpieza - Conservation and Cleaning

Não expor o produto ao sol, altas temperaturas e umidade. Não arrastar objetos sobre a superfície do móvel (ex.: TV, equipamentos eletrônicos, objetos decorativos...). Manter em local seco e arejado. Para a limpeza, utilizar um pano seco e macio. Não é necessário o uso de materiais abrasivos ou álcool.

No exponga el producto a la luz solar, las altas temperaturas y la humedad. No arrastre los objetos en la superficie de la unidad (por ejemplo, TV, equipos electrónicos, objetos de decoración ...). Mantener en un lugar fresco y seco. Para la limpieza, utilizar un paño seco y suave. El uso de materiales abrasivos o del alcohol no es necesario.

Do not expose the product to sunlight, high temperatures and humidity. Do not drag objects across the surface of the unit (TV, electronic equipments, decorative objects ...). Keep it in a cool and dry place. For cleaning, use a dry and soft cloth. Do not use abrasive materials or alcohol.

Garantia

Este certificado de Garantia é uma vantagem adicional oferecida ao consumidor, porém para que o mesmo tenha validade é imprescindível que seja apresentada a NOTA FISCAL de compra do produto.

Com este produto, a **Artely** tem como objetivo atender plenamente o proprietário-consumidor, proporcionando a garantia na forma aqui estabelecida, pelo período de três meses a partir da data da nota fiscal de compra. A **Artely** restringe a sua responsabilidade à substituição gratuita das peças defeituosas, em caso de defeitos ou avarias devidamente constatados como sendo de fabricação, durante a vigência desta garantia.

A **Artely** declara a garantia nula e sem efeito se o produto for alterado, adulterado, molhado ou consertado e ainda pela prática de montagem inadequada ou mau uso. Também será considerada nula em casos de força maior, como aqueles causados por agentes da Natureza (chuvas, incêndios, excesso de umidade, cupins,...) e eventos externos como objetos arrastados sobre a superfície do móvel (ex.: TV, DVD, aparelho de som, objetos decorativos...).

Para exercer seus direitos de comprador é importante que antes de montar seu produto você leia com atenção as instruções de cada passo do manual de montagem que acompanha o móvel.

Caso o produto não esteja em conformidade, entre em contato com a loja onde efetuou a compra e faça sua reclamação, apontando os defeitos técnicos observados. Para agilizar o seu atendimento, tenha sempre em mãos o manual de montagem com os respectivos números das peças defeituosas, conforme descritas no manual.

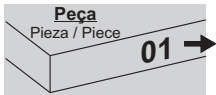



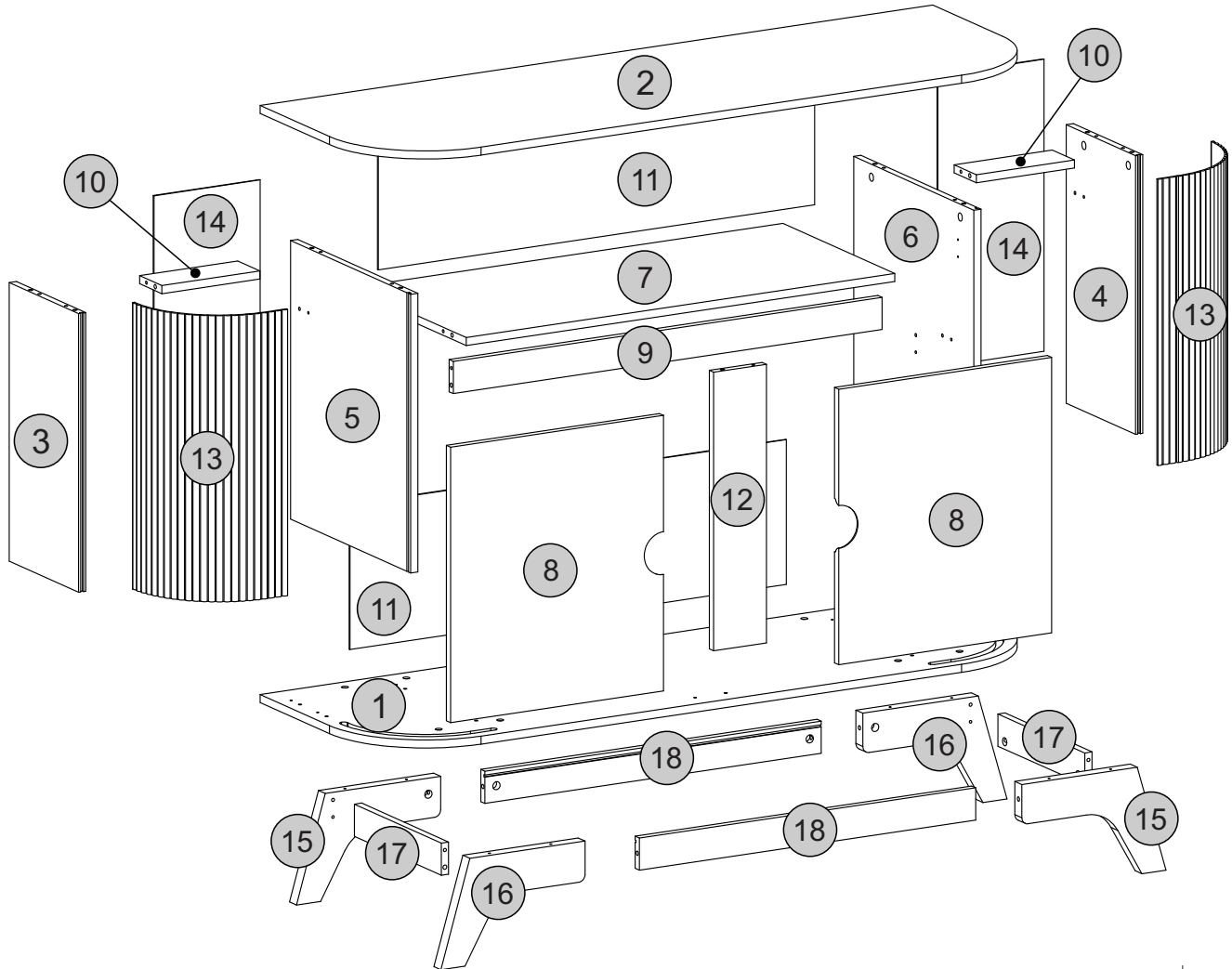
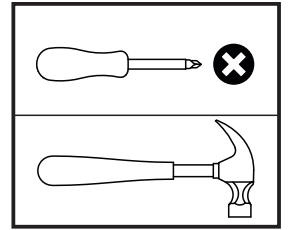





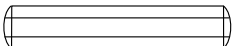

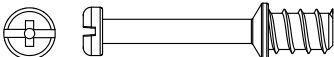

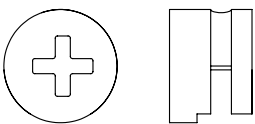
- O número na borda da peça corresponde ao manual.
- Para retirada do número usar Lustra-Móveis, Alcool em Gel ou Borracha.
- El número en el borde de la pieza coincide con el manual.
- Use una goma de borrar blanca, alcohol en gel o lustrador para muebles para eliminar los números.
- The number on the edge of the piece matches the manual.
- Use a White eraser, Alcohol Gel or Furniture Polish to remove the numbers.

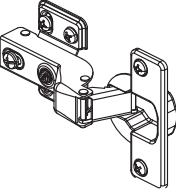

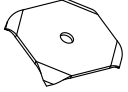
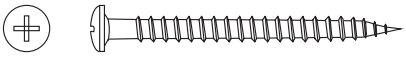
Descrição	Description	Descripción	Qty
1-Base (1400x450x15mm)	1-Base	1-Base	1
2-Tampo (1400x450x15mm)	2-Top	2-Tapa	1
3-Lateral Esquerda (520x250x15mm)	2-Lado izquierdo	3-Left side	1
4-Lateral Direita (520x250x15mm)	4-Lado derecho	4-Right side	1
5-Divisão Esquerda (520x433x15mm)	5-División izquierdo	5-Left Division	1
6-Divisão Direita (520x433x15mm)	6-División derecho	6-Right Division	1
7-Prateleira (892x403x15mm)	7-Anaqueil	7-Shelf	1
8-Porta (514x443x15mm)	8-Puerta	8-Door	2
9-Travessa Prateleira (892x60x15mm)	9-Travessaño anaquel	9-Shelf Rail	1
10-Travessa Traseira (204x80x15mm)	10-Travessaño traseiro	10-Back Rail	2
11-Traseira Central (908x270x3mm)	11-Taseiro central	11-Center Rail	2
12-Travessa Porta (520x110x15mm)	12-Travessaño puerta	12-Door Rail	1
13-Painel (534x316x5mm)	13-Panel	13-Panel	2
14-Traseiro (545x221x3mm)	14-Trasero	14-Back	2
15-Pé Esquerdo (300x200x25mm)	15-Pie Izquierdo	15-Left Foot	2
16-Pé Direito(300x200x25mm)	16-Pie Derecho	16-Right Foot	2
17-Travessa Pé (313x60x15mm)	17-Travessaño Pie	17-Foot Rail	2
18-Travessa (700x60x15mm)	18-Travessaño	18-Rail	2

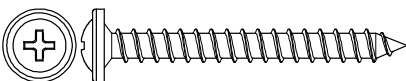
Lista de Materiais Lista de Materiales/ Hardware List

A		Cavilha / Tarugo / Dowel Ø6x30mm	32	I		Produto Moldado / Silicona / Silicone	04
B		Minifix Minifix / Minifix Ø7x30mm	24	J		Haste Dupla Minifix Minifix Doble Varilla / Double Rod Minifix	04
C		Tambor Tambor / Minifix Cam Ø15x12mm	32	K		Sapata Fixa / Pata Fija / Fixed Foot Ø5x10mm	04
D		Tapa furo adesivo / Adhesivo / Hole Cover Ø18mm	08	L		Dobradiça / Bisagra / Hinge / Metal - 35mm	04
E		Parafuso / Tornillo / Screw Ø4,0x14mm CP	36	M		Fixador / Fijador / Fixer	16
F		Parafuso Tornillo / Screw Ø3,5x40mm CP	08	N		Suporte Angular Soporte Angular / Plastic Corner Brace	06
G		Parafuso Tornillo / Screw Ø5,0x40mm	08				
H		Prego / Clavo / Nail 8x8	42				

DICAS PARA FIXAR MINIFIX

TIP TO FASTEN THE MINIFIX
PISTA PARA ARREGLAR EL MINIFIX

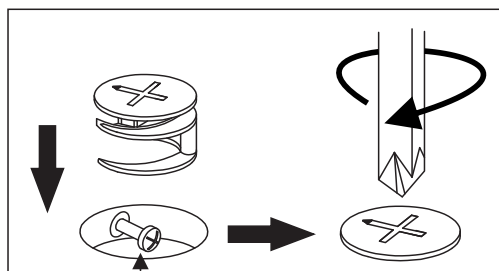

Cabeça do parafuso precisa estar no centro

La cabeza del tornillo debe estar en el centro

Screw head has to be in the center

Parafuso Minifix

Tornillo minifix/Minifix screw

Fixe o parafuso até o ressalto encostar na superfície da peça (veja o exemplo abaixo).

Tighten the screw until its overhang part lean on the piece surface (see the example below).

Fije el tornillo hasta que su parte sobresaliente toque la superficie de la pieza (vea el ejemplo abajo).

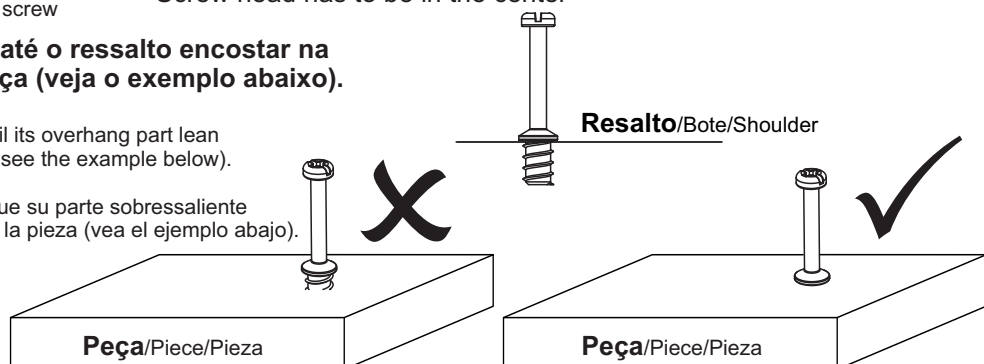

Passo 1

Paso/Step

PEÇA
Pieza/Piece

1 - BASE x1

FERRAGEM
Herraje/Hardware

B  01

FERRAMENTA
Herramienta/Tool

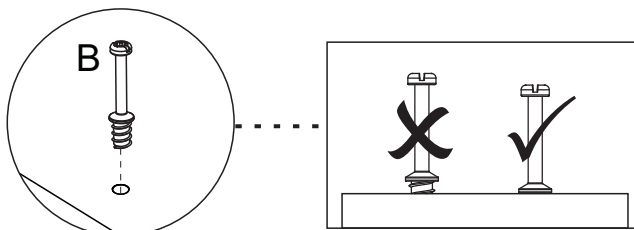
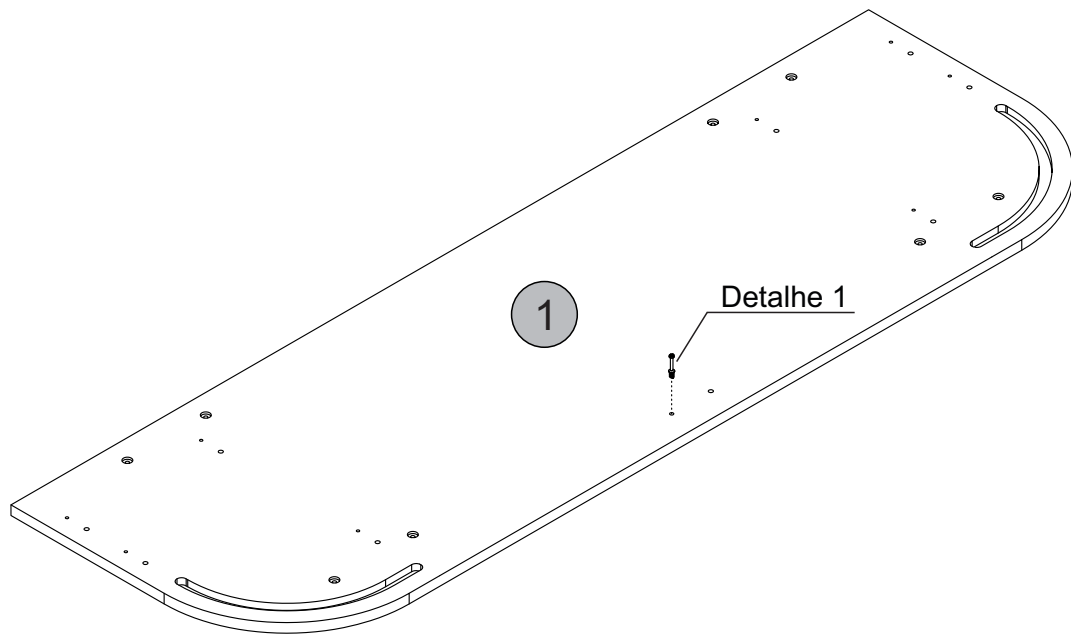
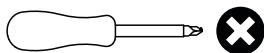

Detalhe 1
Detalle/Detail

Passo 2

Paso/Step

PEÇA
Pieza/Piece

2 - TAMPO x1

FERRAMENTA
Herramienta/Tool

B  09

FERRAMENTA
Herramienta/Tool

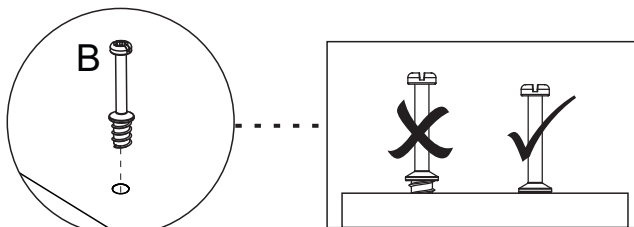
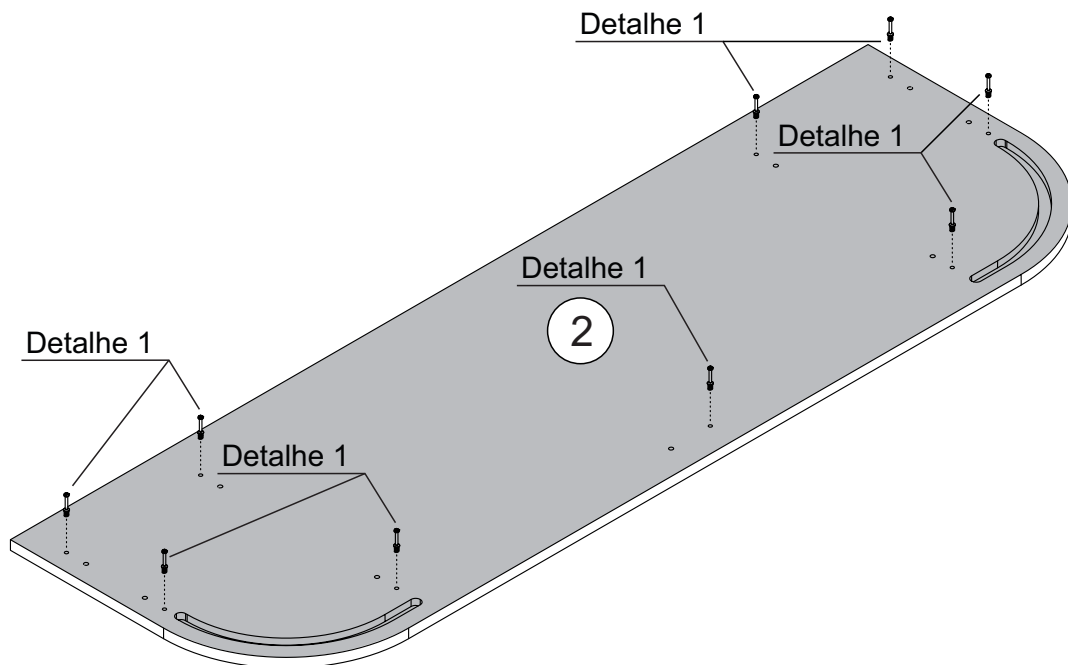
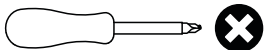

Detalhe 1
Detalle/Detail

Passo 3

Paso/Step

PEÇA
Piece/Pieza

3 - LATERAL ESQUERDA x1

4 - LATERAL DIREITA x1

FERRAGEM
Hardware/Herraje

A  08

B  02

FERRAMENTA
Tool/Herramienta

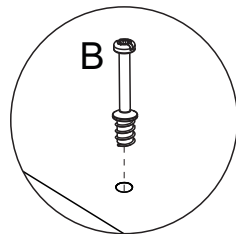
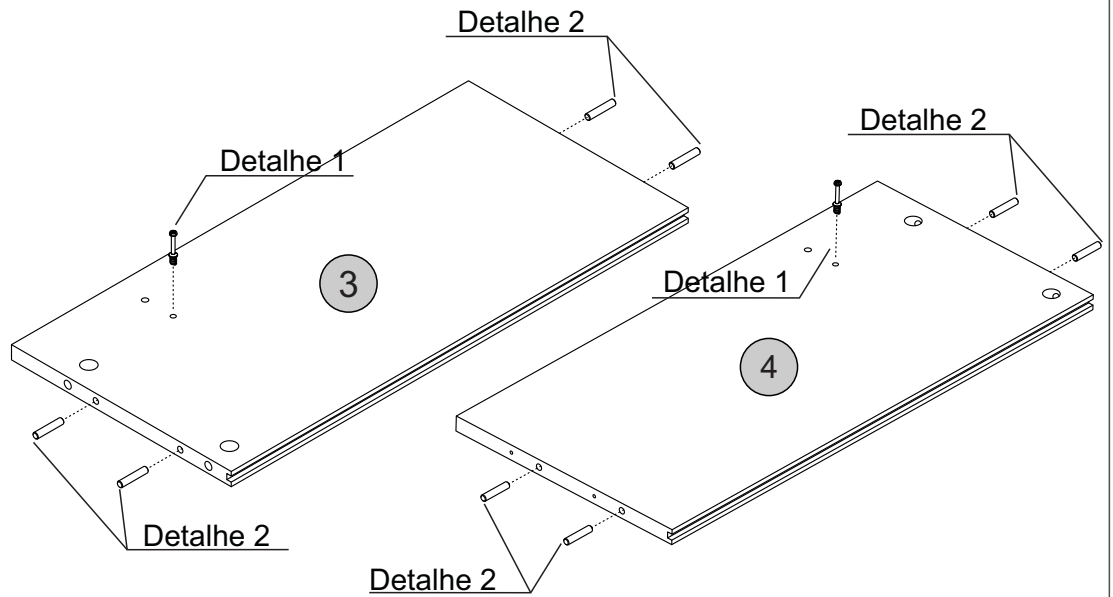
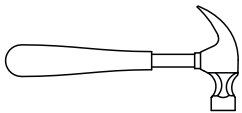
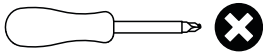

Detalhe 1
Detalle/Detail

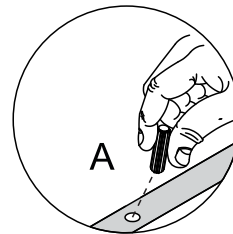
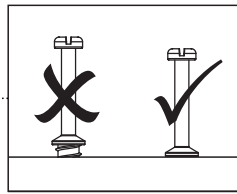

Detalhe 2
Detail/Detalle

Passo 4

Paso/Step

PEÇA
Piece/Pieza

4 - LATERAL DIREITA

FERRAGEM
Hardware/Herraje

A  04

B  04

FERRAMENTA
Tool/Herramienta

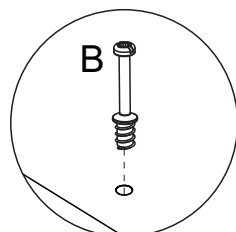
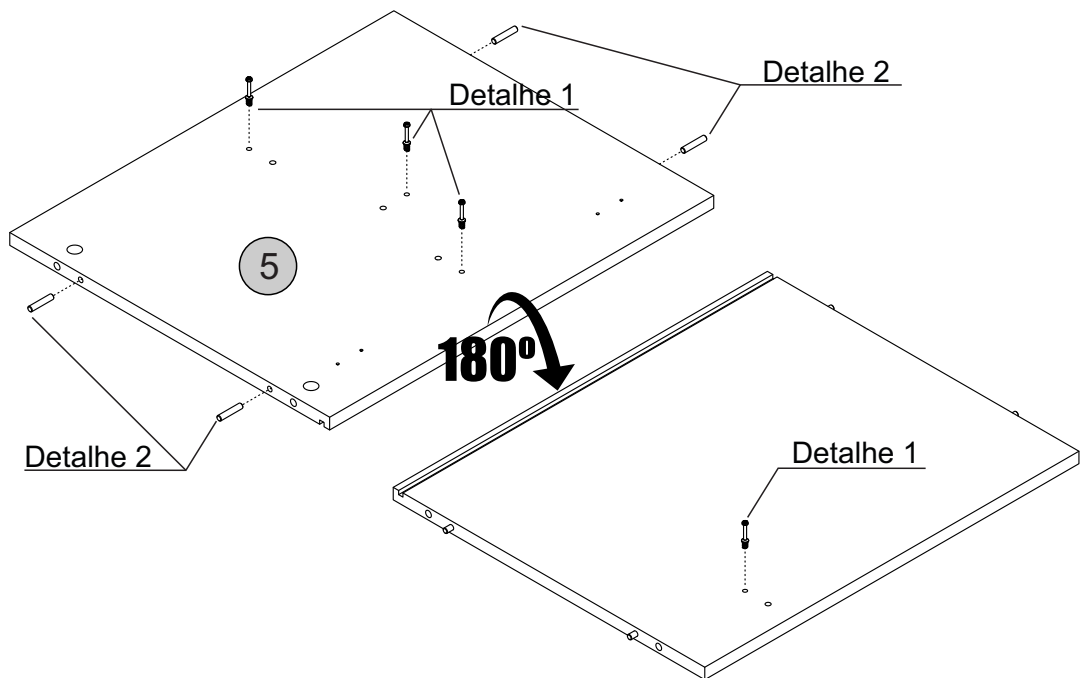
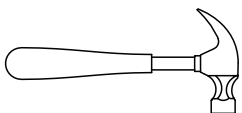
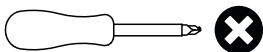

Detalhe 1
Detalle/Detail

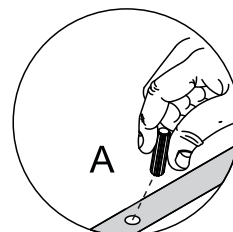
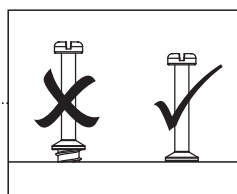

Detalhe 2
Detail/Detalle

Passo 5

Paso/Step

PEÇA
Pieza/Pieza

6 - DIVISÃO DIREITA x1

FERRAGEM
Hardware/Herraje

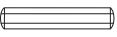
A  04

B  04

FERRAMENTA
Tool/Herramienta

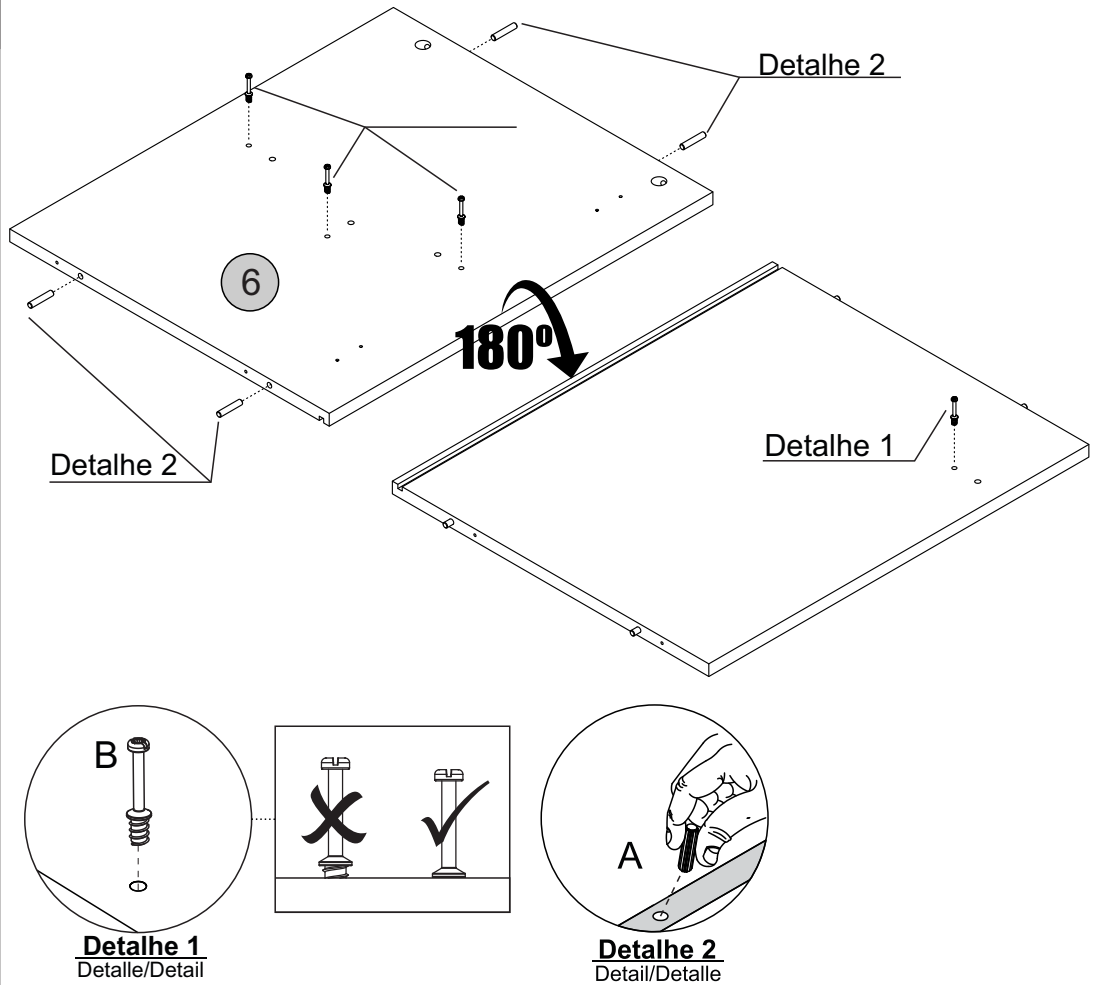
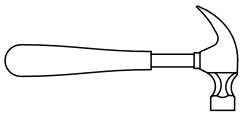
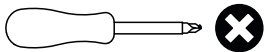

Passo 6

Paso/Step

PEÇA
Pieza/Pieza

7 - PRATELEIRA x1

9 - TRAVESSA PRATELEIRA x1

10 - TRAVESSA TRASEIRA x2

12 - TRAVESSA PORTA x1

17 - TRAVESSA PÉ x2

FERRAGEM
Herraje/Hardware

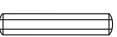
A  16

FERRAMENTA
Herramienta/Tool

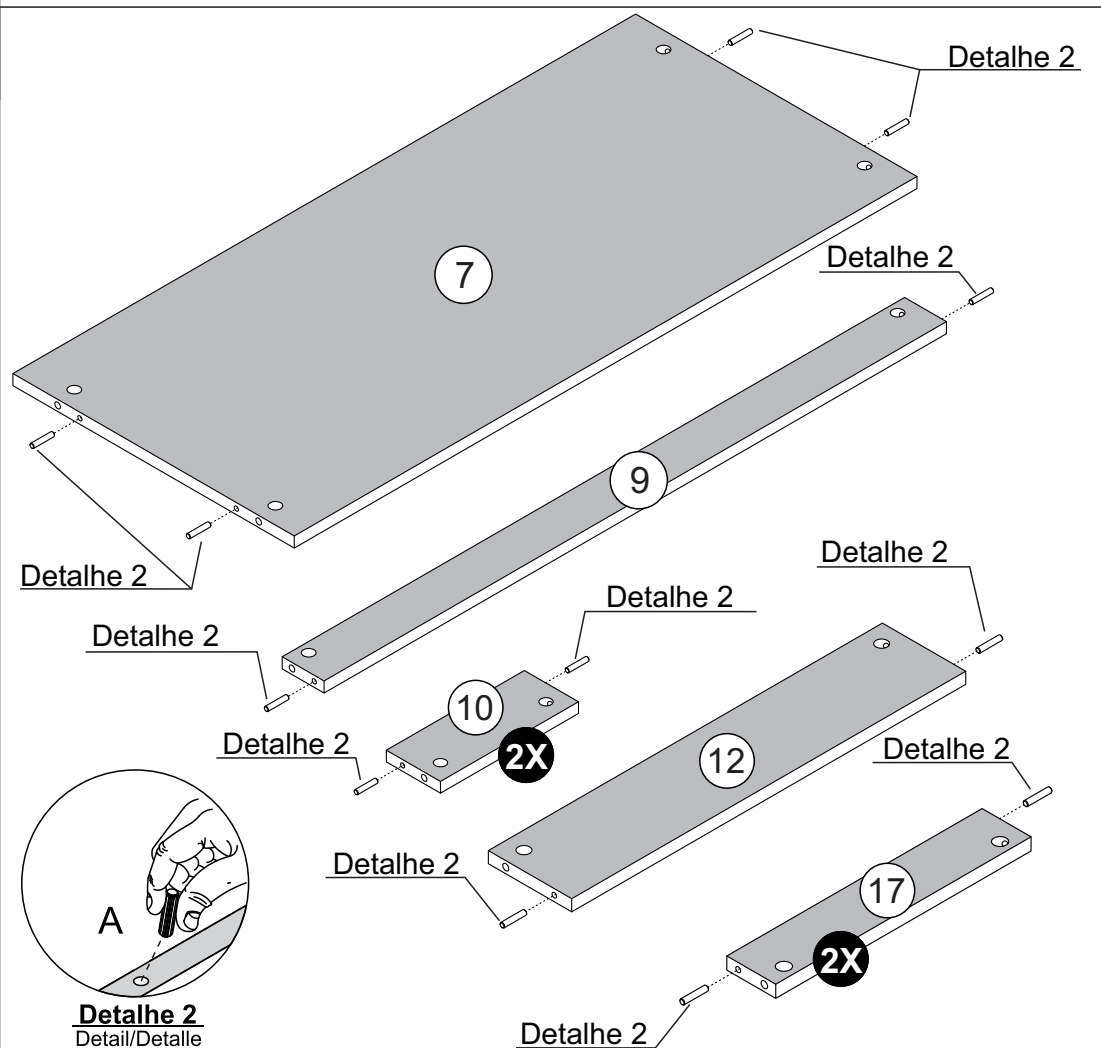
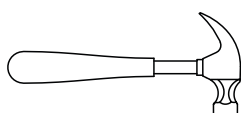

Passo 7

Paso/Step

PEÇA
Pieza/Piece

8 - PORTA x2

FERRAGEM
Herraje/Hardware

E  08

L  04

FERRAMENTA
Herramienta/Tool

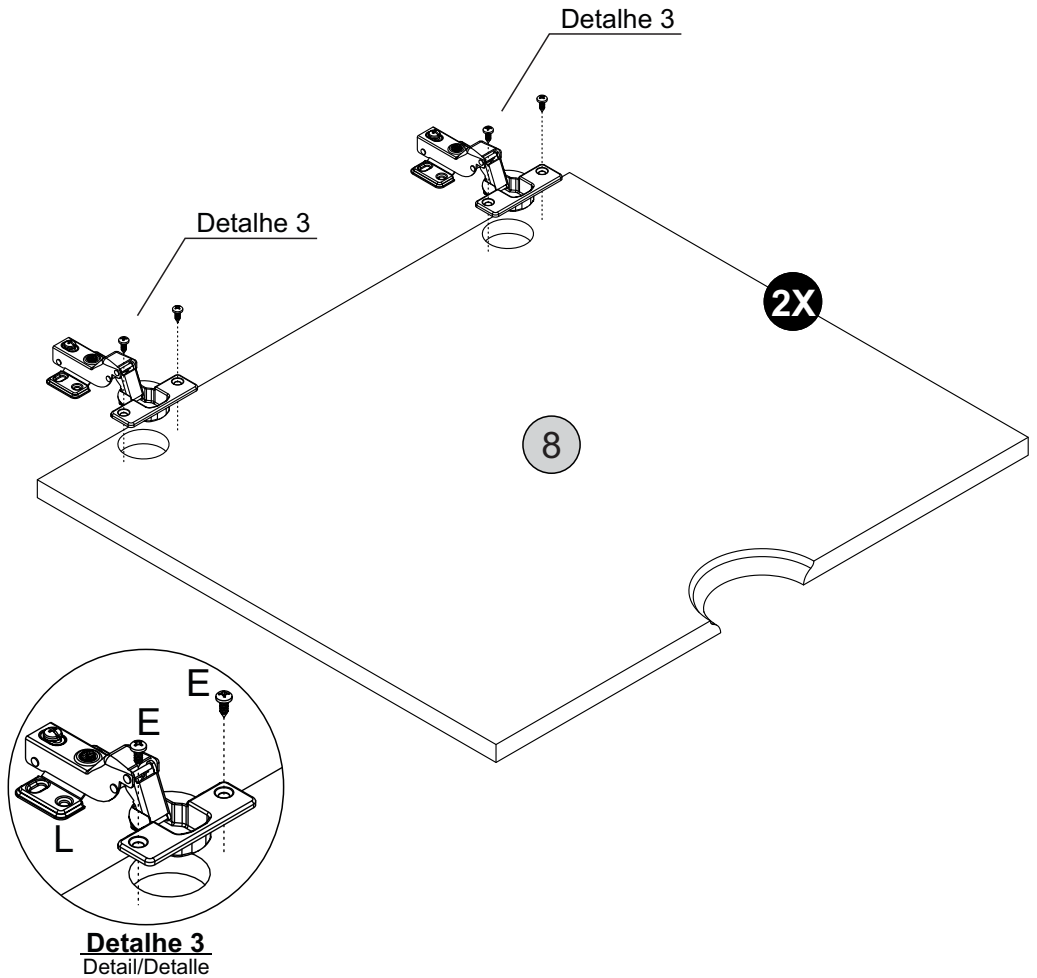
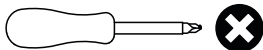

Passo 8

Paso/Step

PEÇA
Pieza/Piece

15 - PÉ ESQUERDO x2

16 - PÉ DIREITO x2

FERRAGEM
Herraje/Hardware

B  04

K  04

FERRAMENTA
Herramienta/Tool

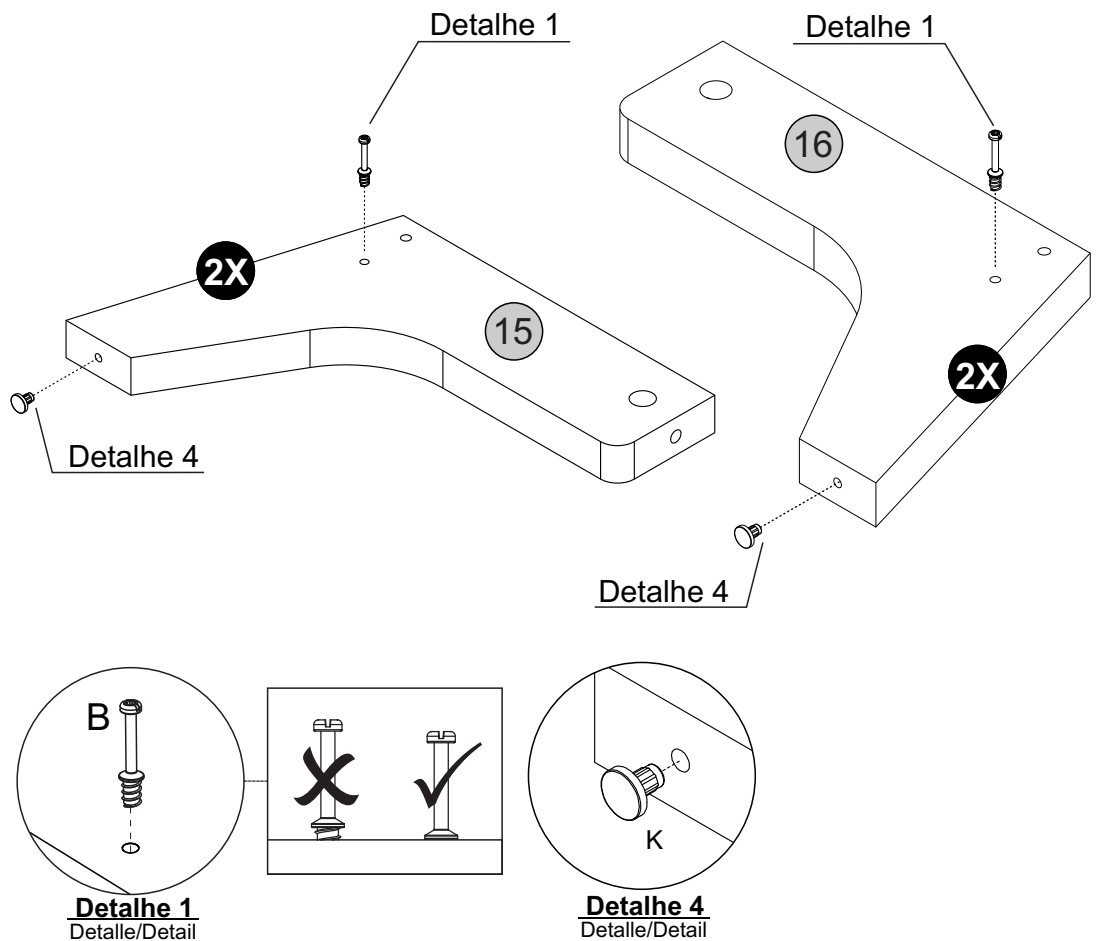
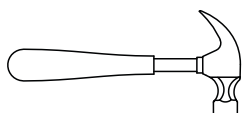
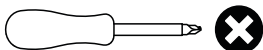

Passo 9

Paso/Step

PEÇA
Piece/Pieza

15 -PÉ ESQUERDO 2X

16 -PÉ DIREITO 2X

18 -TRAVESSA 2X

FERRAGEM
Hardware/Herraje

C  08

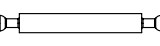
J  04

FERRAMENTA
Tool/Herramienta

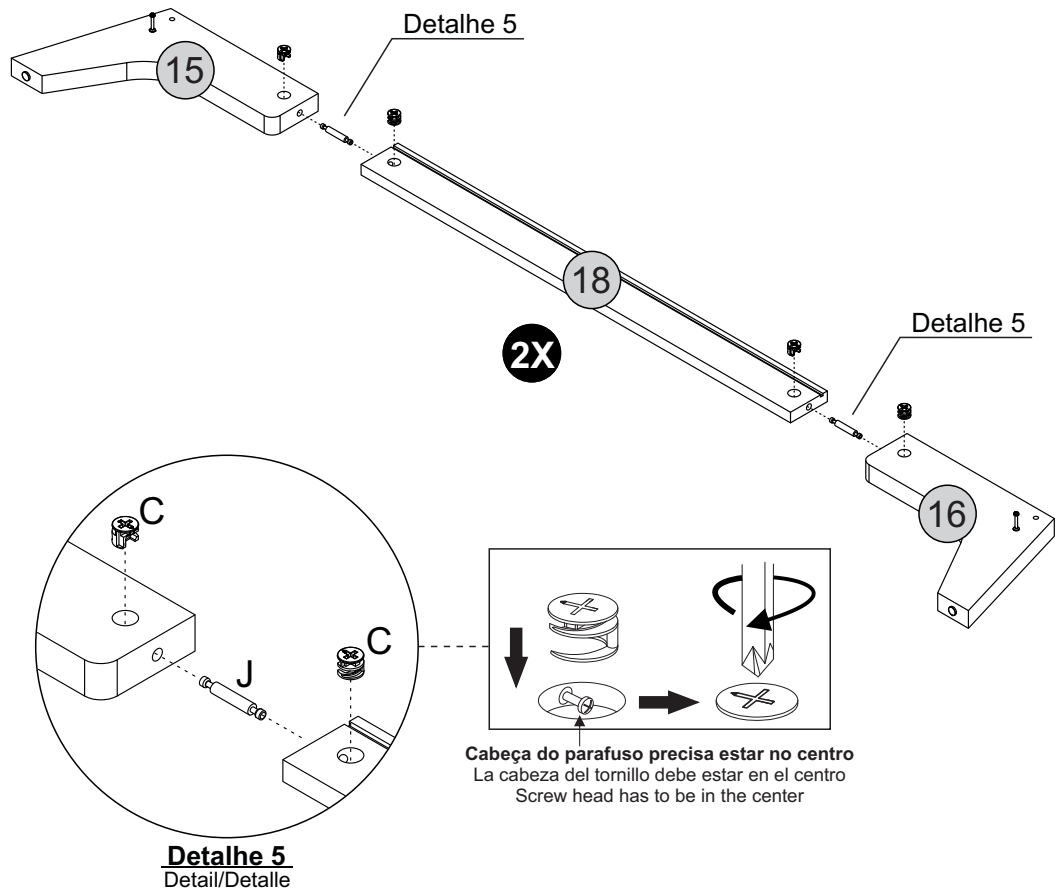
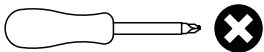

Passo 10

Paso/Step

PEÇA
Piece/Pieza

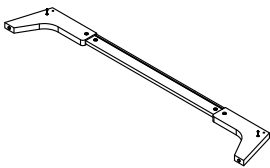

FERRAGEM
Hardware/Herraje

E  06

L  06

FERRAMENTA
Tool/Herramienta

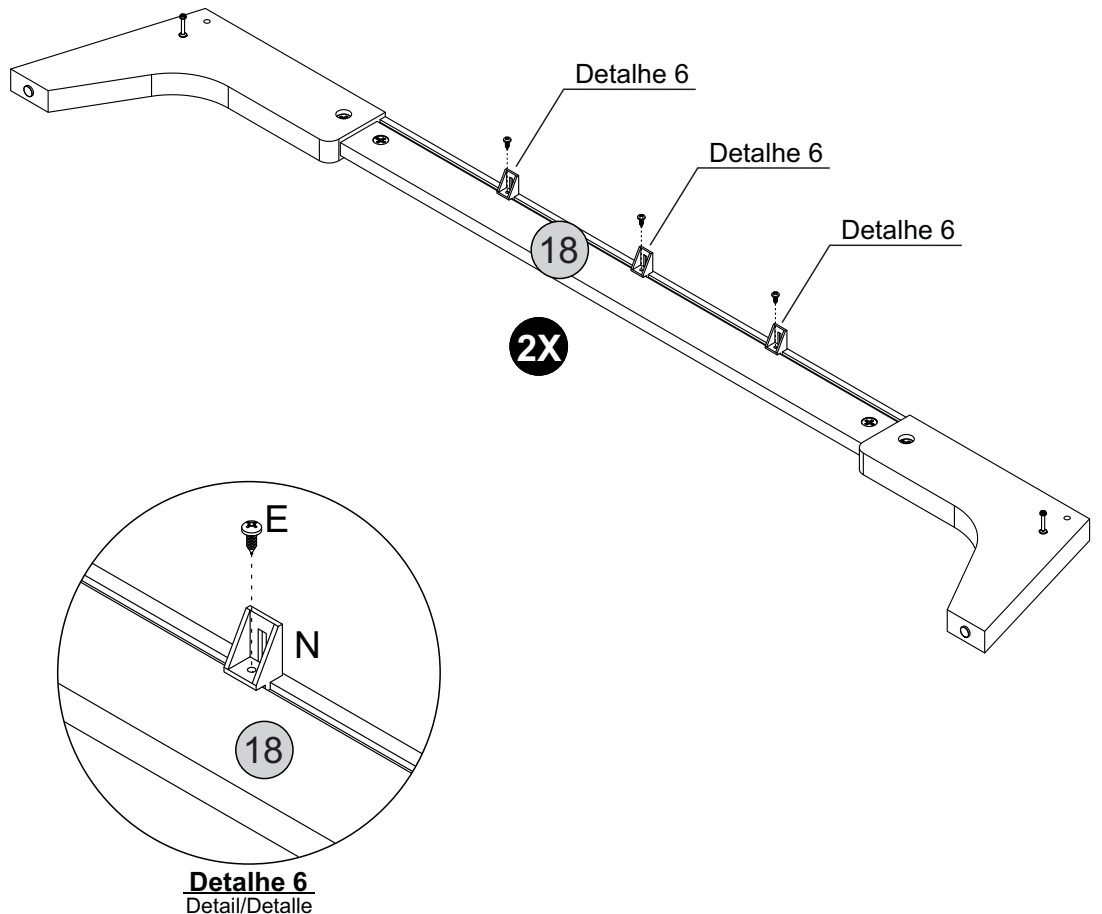
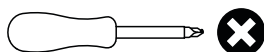

Passo 11

Paso/Step

PEÇA
Pieza/Piece

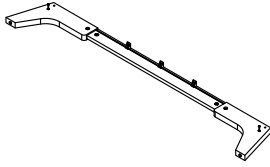

17 - TRAVESSA PÉ x2

FERRAGEM
Herraje/Hardware



FERRAMENTA
Herramienta/Tool

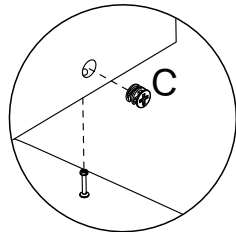
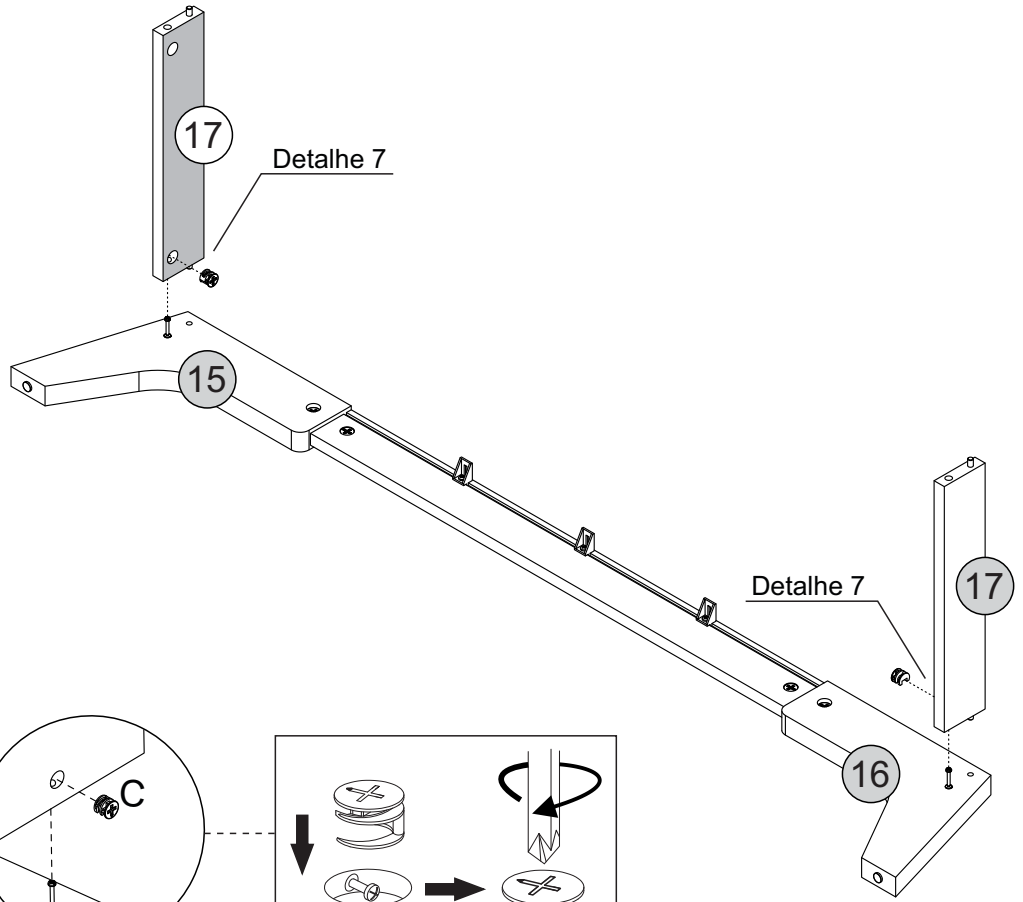
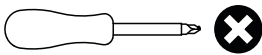

Detalhe 7
Detalle/Detail

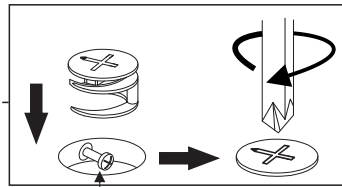

Cabeça do parafuso precisa estar no centro
La cabeza del tornillo debe estar en el centro
Screw head has to be in the center

Passo 12

Paso/Step

PEÇA
Pieza/Piece

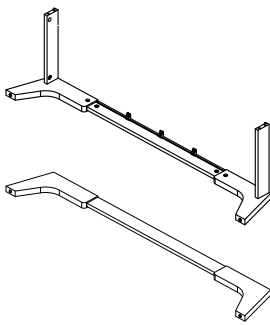

FERRAGEM
Herraje/Hardware

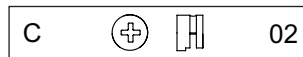

FERRAMENTA
Herramienta/Tool

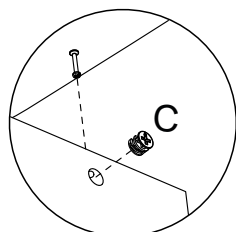
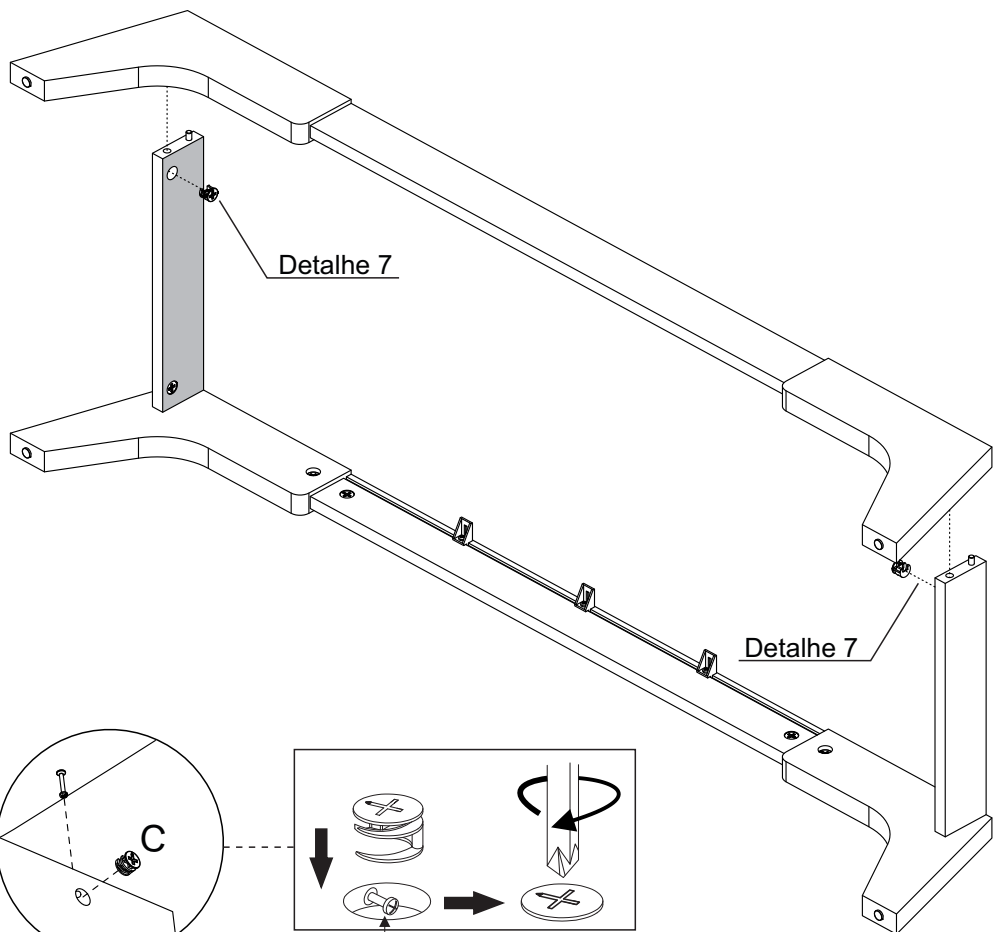
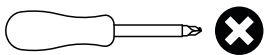

Detalhe 7
Detalle/Detail

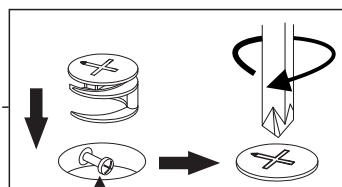

Cabeça do parafuso precisa estar no centro
La cabeza del tornillo debe estar en el centro
Screw head has to be in the center

Passo 13

Paso/Step

PEÇA
Pieza/Piece

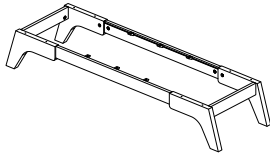

1 - BASE x1

FERRAGEM
Herraje/Hardware

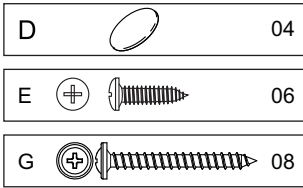

FERRAMENTA
Herramienta/Tool

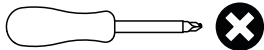

Detalhe 8

Detalhe 8

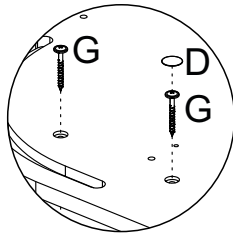
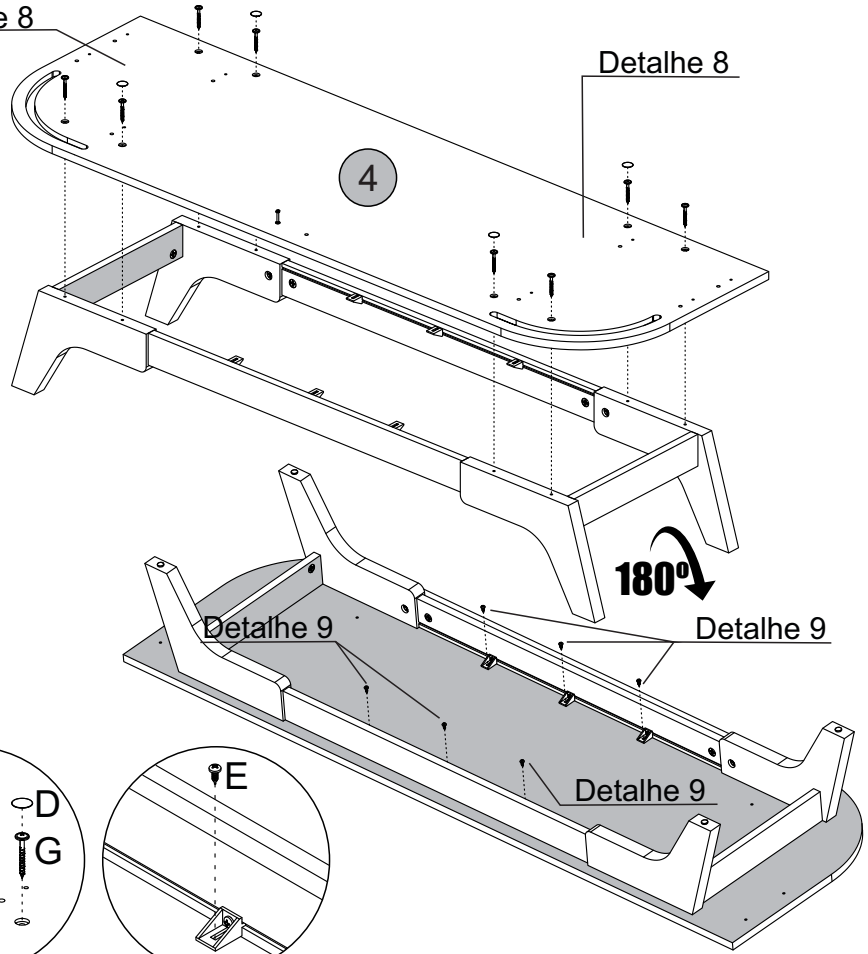

Detalhe 8
Detalle/Detail

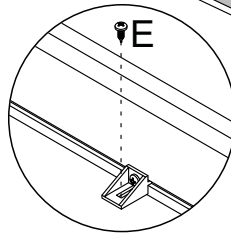

Detalhe 9
Detalle/Detail

Passo 14

Paso/Step

PEÇA
Pieza/Piece

6 - DIVISÃO DIREITA x1

7 - PRATELEIRA x1

FERRAGEM
Herraje/Hardware

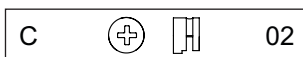

FERRAMENTA
Tool/Herramienta

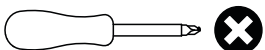

Detalhe 7

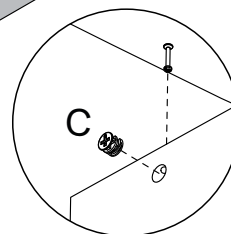
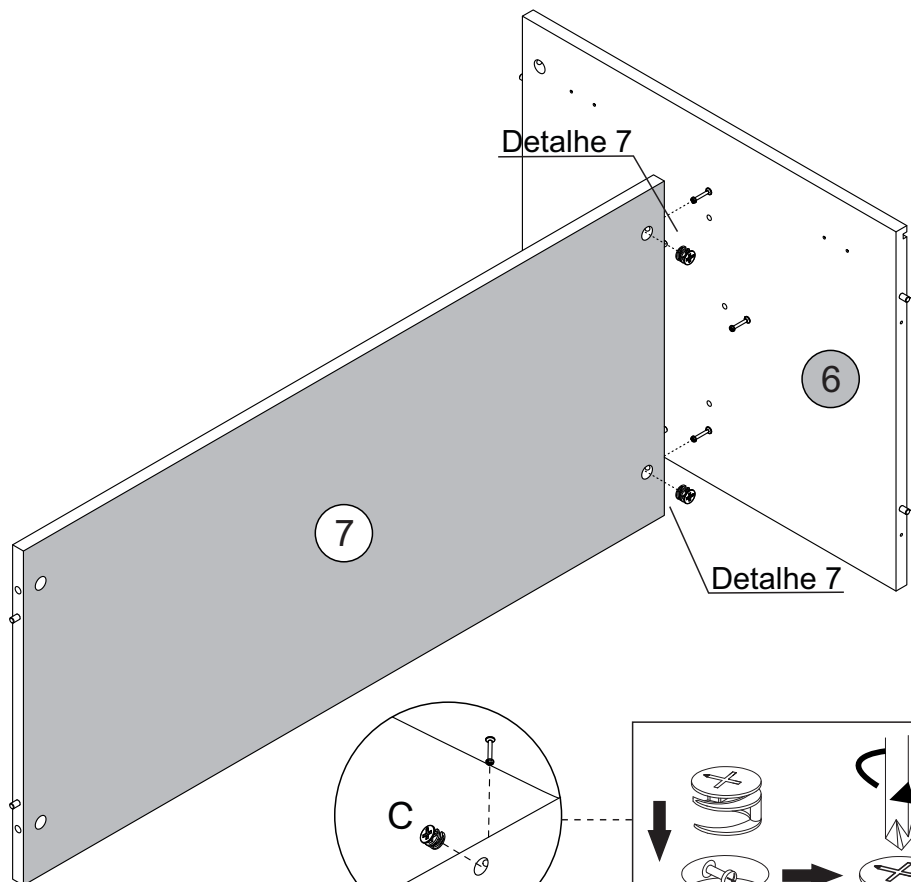

Detalhe 7
Detalle/Detail

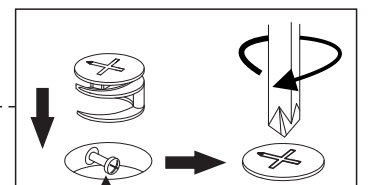

Cabeça do parafuso precisa estar no centro
La cabeza del tornillo debe estar en el centro
Screw head has to be in the center

Passo 15

Paso/Step

PEÇA
Pieza/Piece

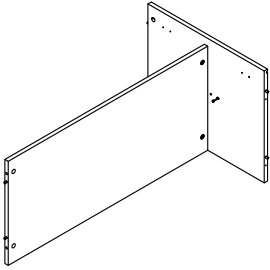

5 - DIVISÃO ESQUERDA x1

9 - TRAVESSA PRATELEIRA x1

FERRAGEM
Herraje/Hardware



FERRAMENTA
Herramienta/Tool

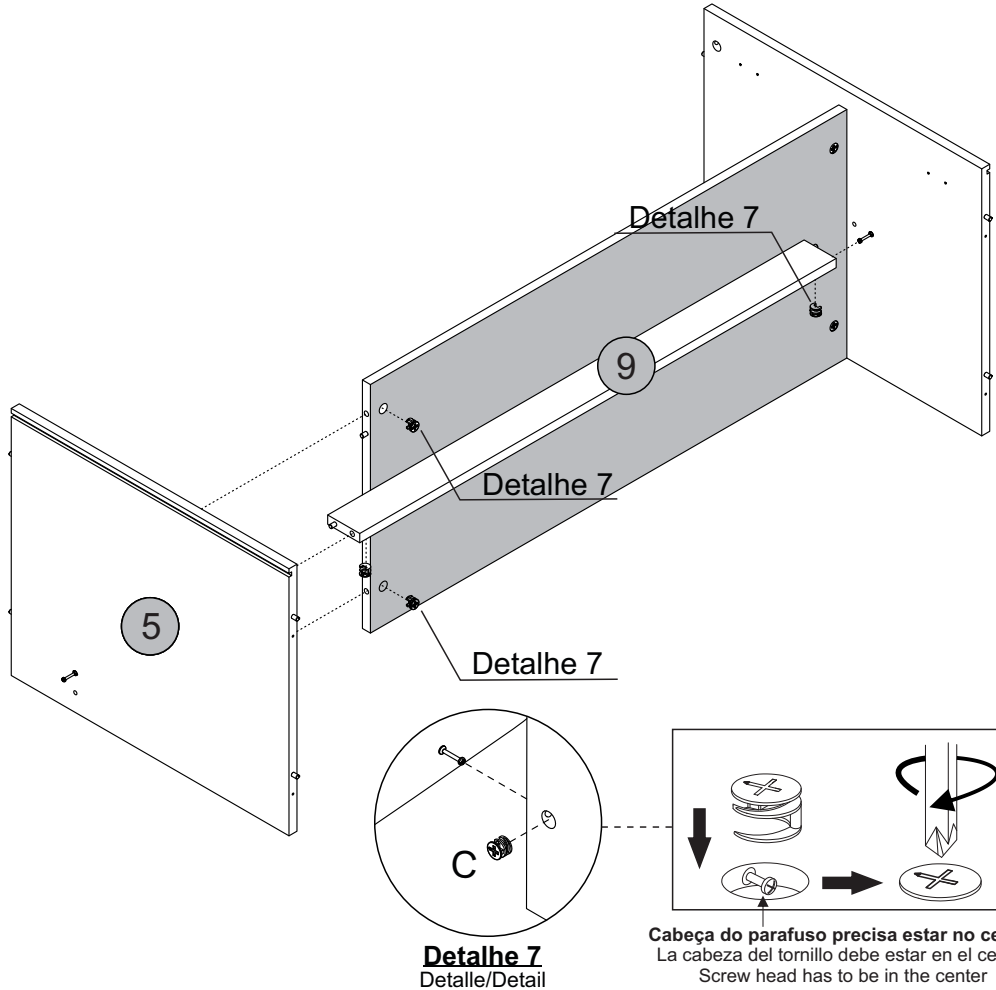
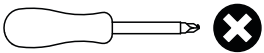

Passo 16

Paso/Step

PEÇA
Pieza/Piece

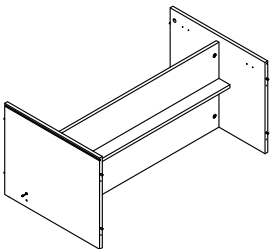

3 - LATERAL ESQUERDA x1

10 - TRAVESSA TRASEIRA x1

FERRAGEM
Herraje/Hardware



FERRAMENTA
Tool/Herramienta

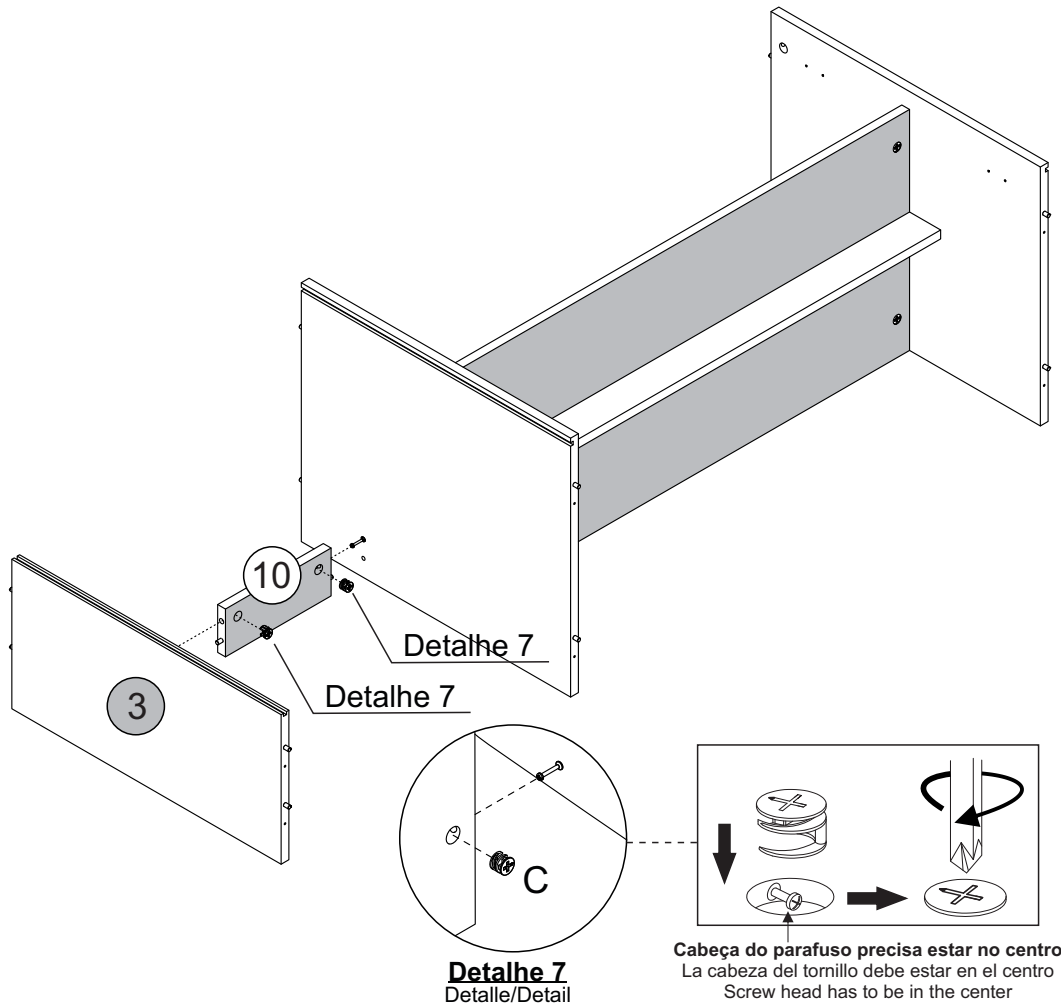
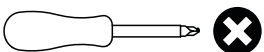

Passo 17

Paso/Step

PEÇA
Pieza/Piece

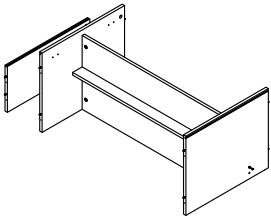

4 - LATERAL DIREITA x1

10 - TRAVESSA TRASEIRA x1

FERRAGEM
Herraje/Hardware



FERRAMENTA
Herramienta/Tool

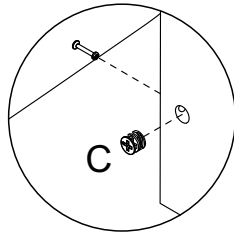
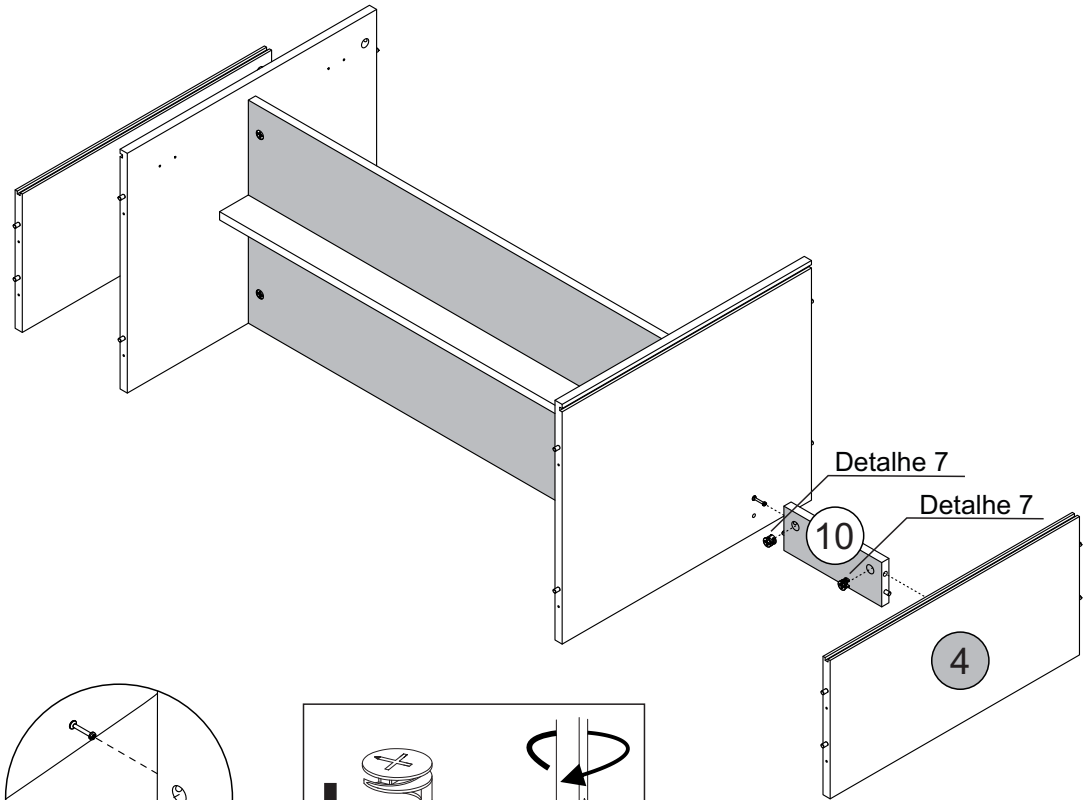
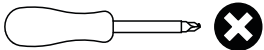

Detalhe 7
Detalle/Detail

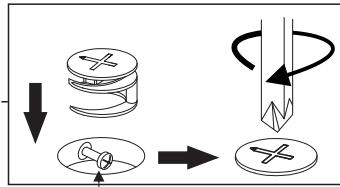

Cabeça do parafuso precisa estar no centro
La cabeza del tornillo debe estar en el centro
Screw head has to be in the center

Passo 18

Paso/Step

PEÇA
Pieza/Piece

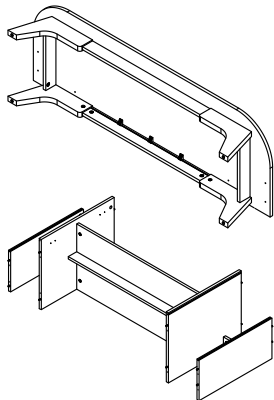

FERRAGEM
Herraje/Hardware



FERRAMENTA
Herramienta/Tool

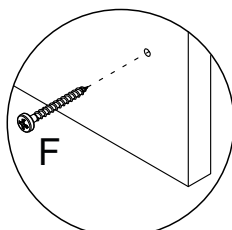
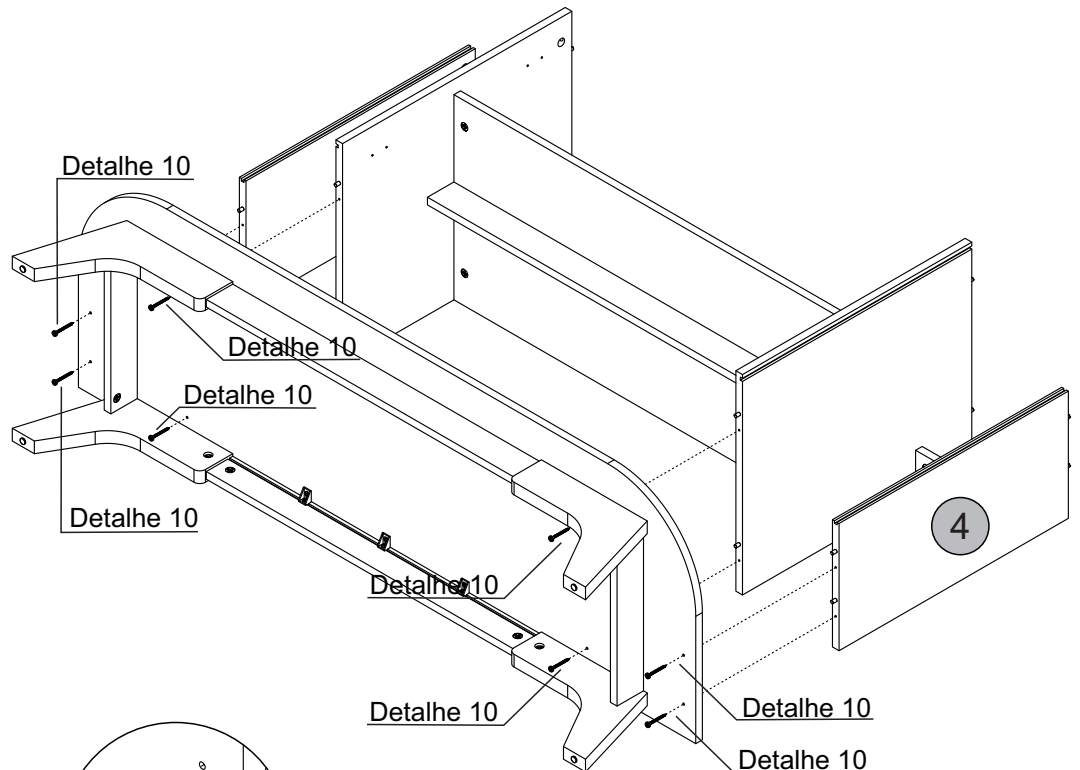
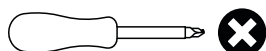

Detalhe 10
Detalle/Detail

Passo 19

Paso/Step

PEÇA
Pieza/Piece

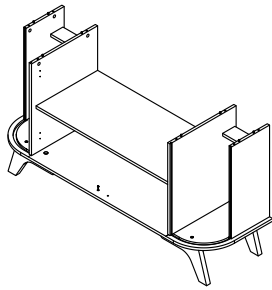

12 - TRAVESSA PORTA x1

13 - PAINEL x2

FERRAGEM
Herraje/Hardware



FERRAMENTA
Herramienta/Tool

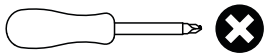

Atenção
ATENCIÓN!
ATTENTION!

Peça nº 13 é frágil,
cuidado
no manuseio.

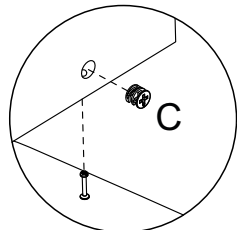
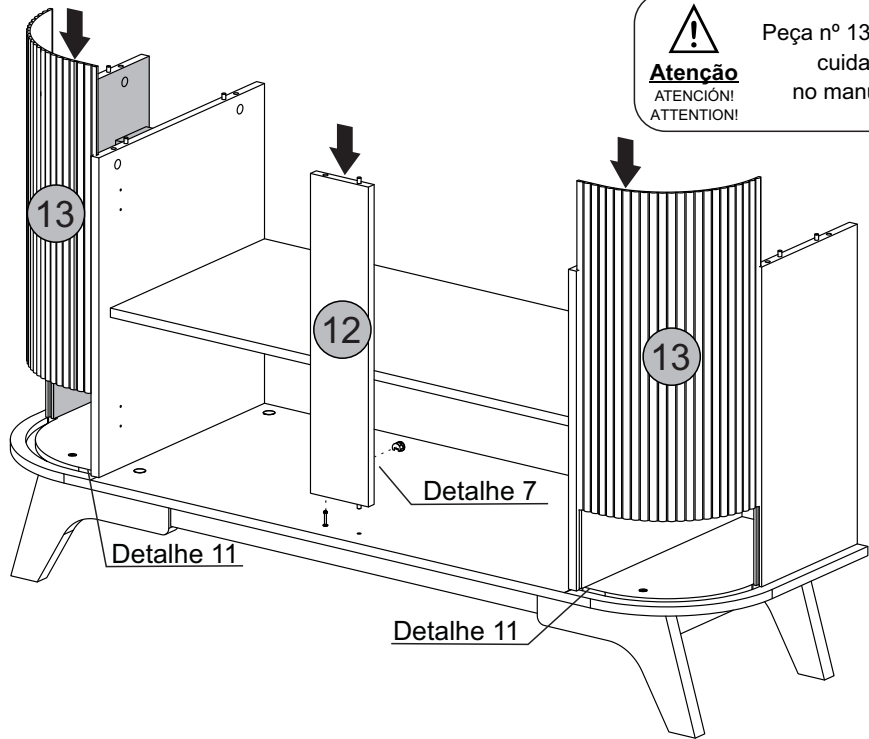

Detalhe 7
Detalle/Detail

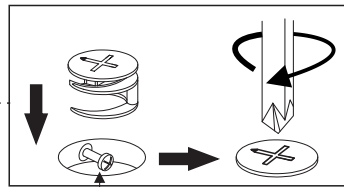

Cabeça do parafuso precisa estar no centro
La cabeza del tornillo debe estar en el centro
Screw head has to be in the center

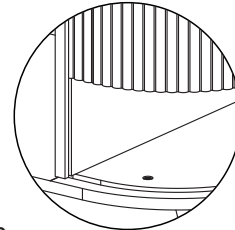

Detalhe 11
Detalle/Detail

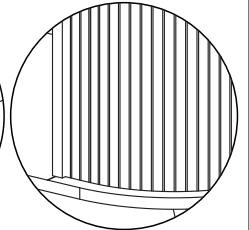

Passo 20

Paso/Step

PEÇA
Pieza/Piece

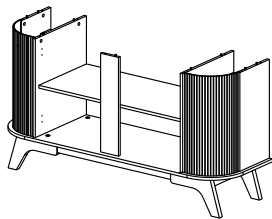

2 - TAMPO x1

FERRAGEM
Hardware/Herraje

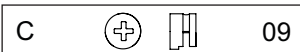

FERRAMENTA
Tool/Herramienta

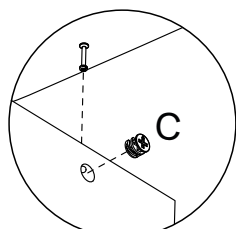
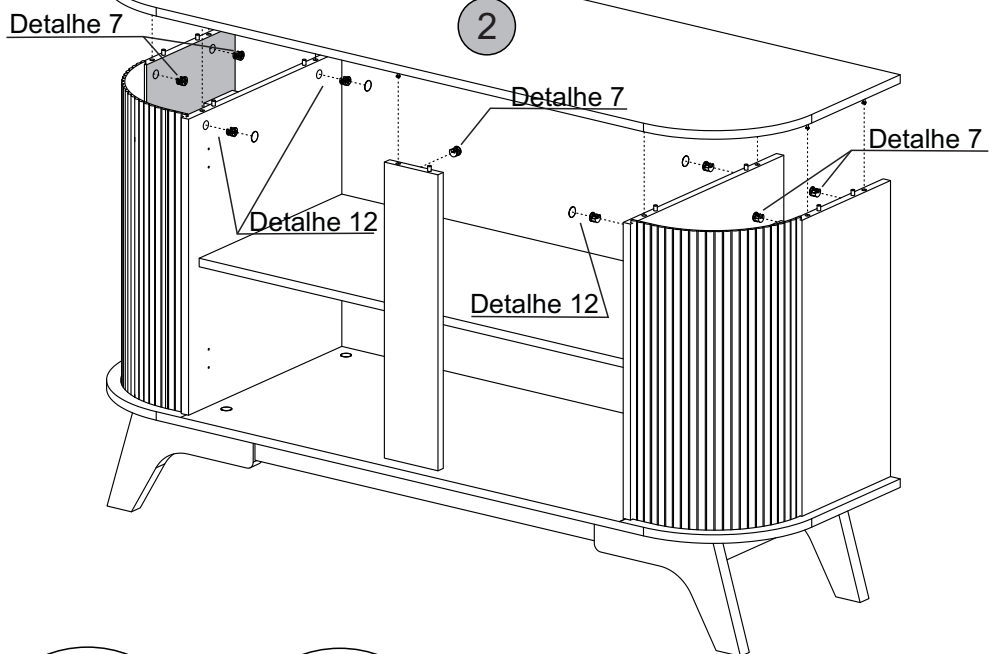
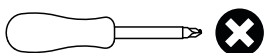

Detalhe 7
Detalle/Detail

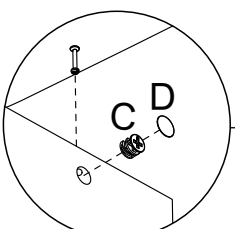

Detalhe 12
Detalle/Detail

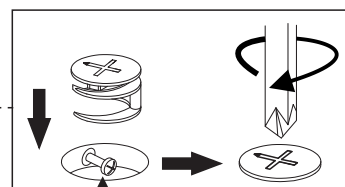

Cabeça do parafuso precisa estar no centro
La cabeza del tornillo debe estar en el centro
Screw head has to be in the center

Passo 21

Paso/Step

PEÇA
Pieza/Piece

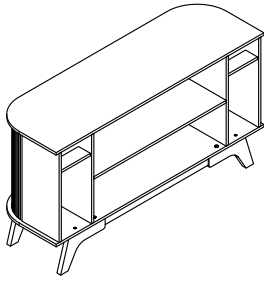

11 - TRASEIRA CENTRAL x2

FERRAGEM
Herraje/Hardware

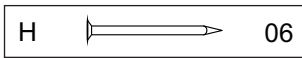

FERRAMENTA
Herramienta/Tool

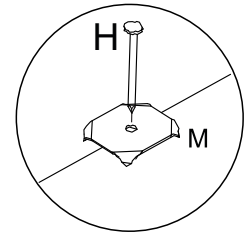
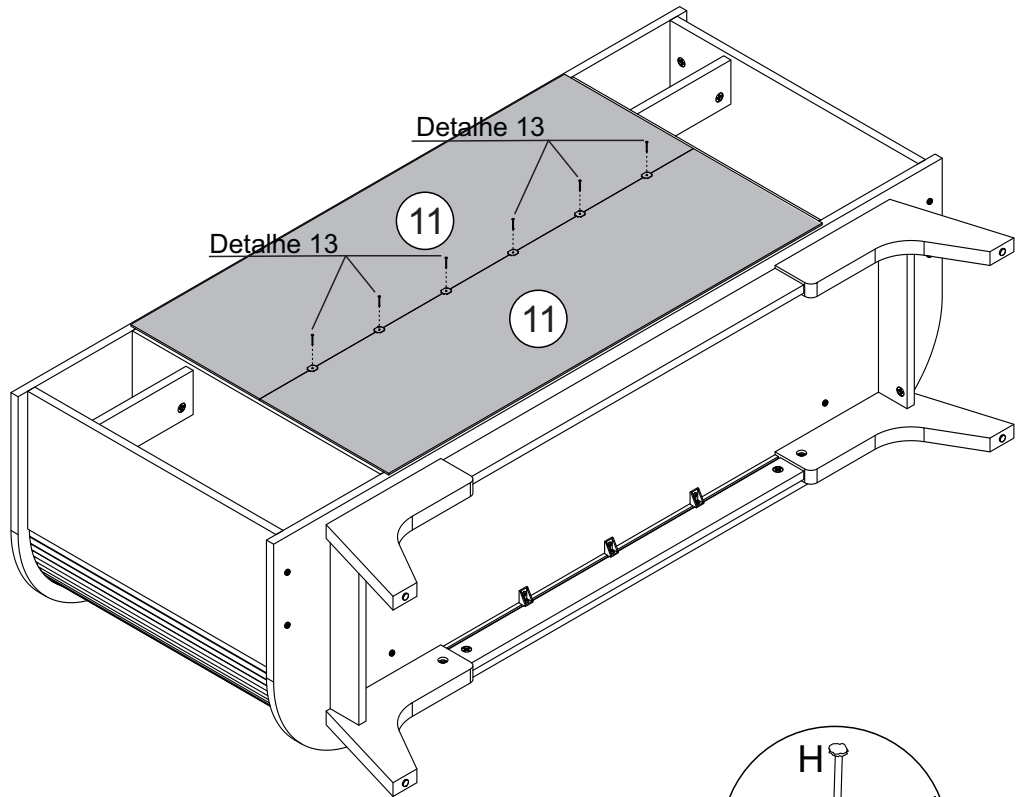
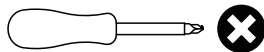

Detalhe 13
Detail/Detalle

Passo 22

Paso/Step

PEÇA
Pieza/Piece

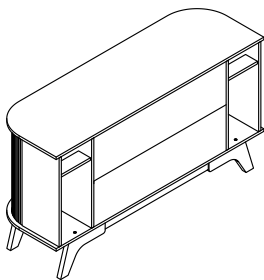

14 - TRASEIRA LATERAL x2

FERRAGEM
Herraje/Hardware

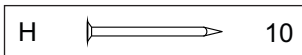

FERRAMENTA
Herramienta/Tool

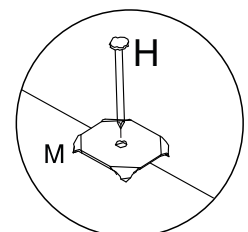
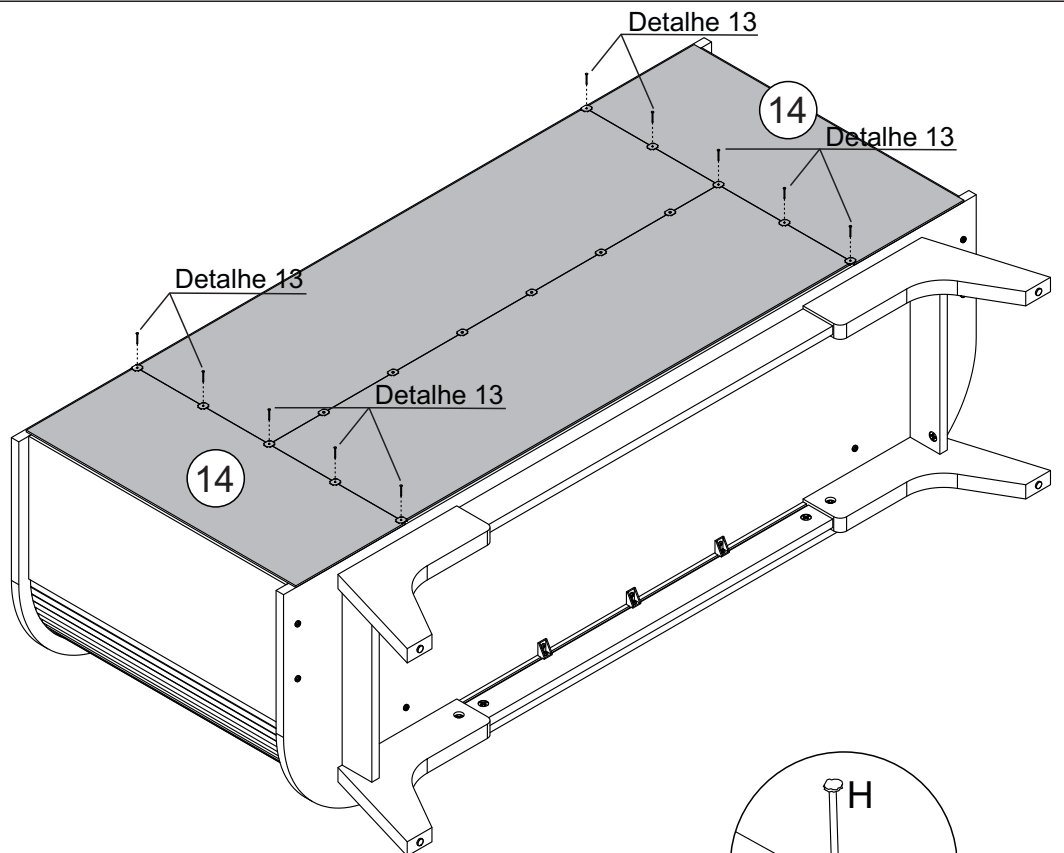
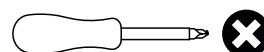

Detalhe 13
Detail/Detalle

Passo 23

Paso/Step

PEÇA
Pieza/Piece

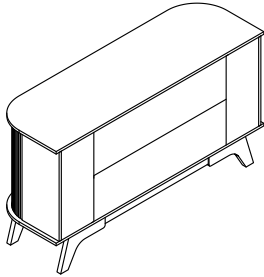

FERRAGEM
Herraje/Hardware

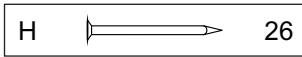

FERRAMENTA
Herramienta/Tool

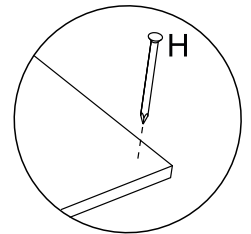
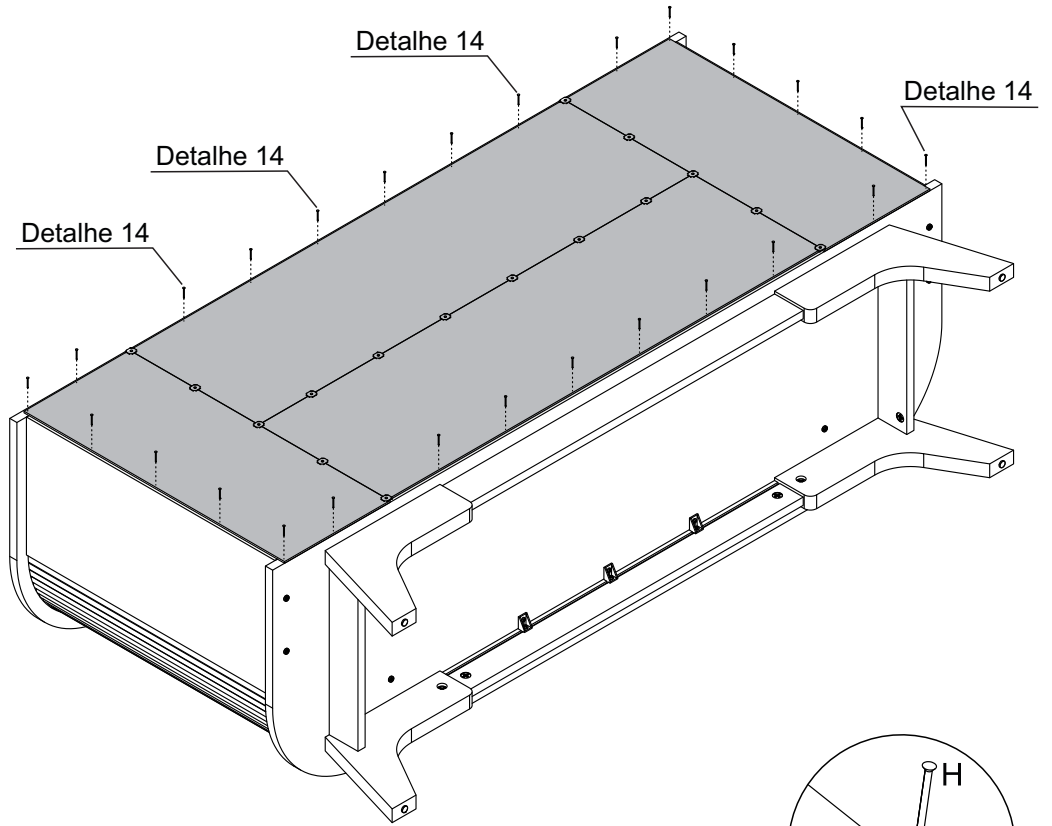
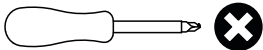

Detalhe 14
Detail/Detalle

Passo 24

Paso/Step

PEÇA
Pieza/Piece

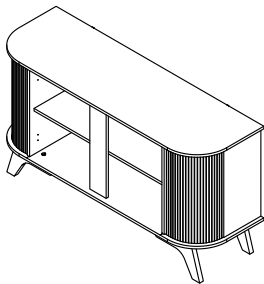

8 - PORTA x1

FERRAGEM
Herraje/Hardware

FERRAMENTA
Herramienta/Tool

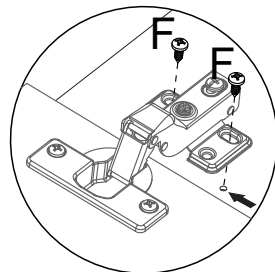
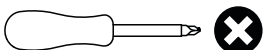

Passo A
Paso/Step

Ajustar porta.

Ajusta puerta. / Adjust door.

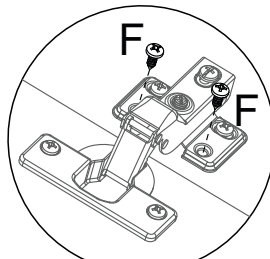

Passo B
Paso/Step

Fixa porta

arreglar puerta. / fix door.



Ajuste de Largura
Ajuste de ancho
Width Adjustment



Ajuste Interno
Ajuste Interno
Internal Adjustment

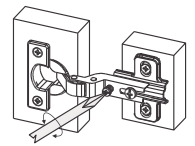
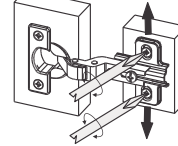

Ajuste de Profundidade
Ajuste de profundidad
Depth Adjustment

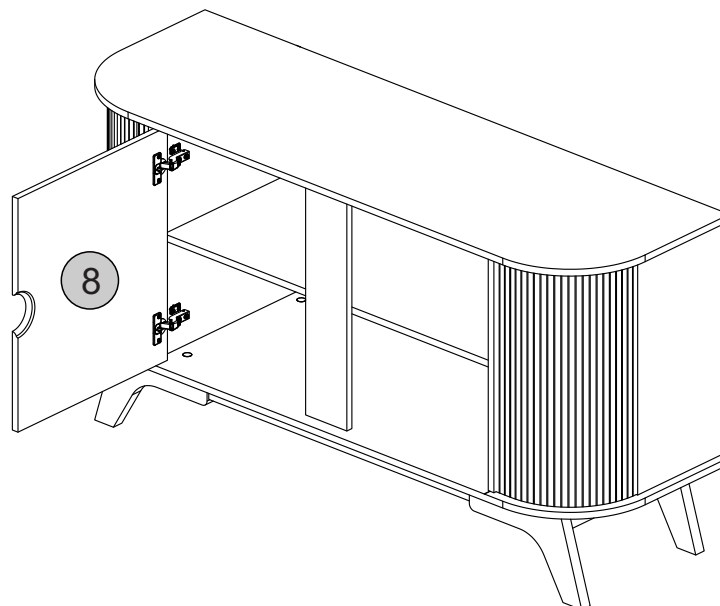

Passo 25

Paso/Step

PEÇA
Pieza/Piece

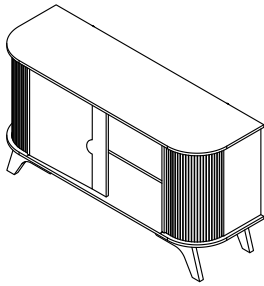

8 - PORTA

x1

FERRAGEM
Herraje/Hardware

FERRAMENTA
Herramienta/Tool

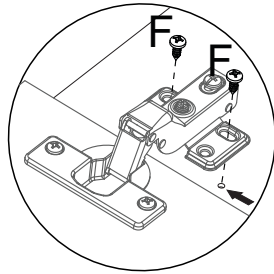
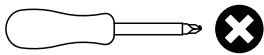

Passo A
Paso/Step

Ajustar porta.

Ajusta puerta. / Adjust door.

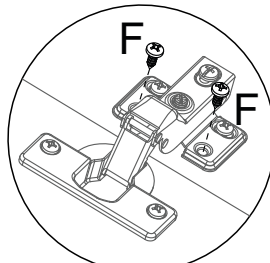

Passo B
Paso/Step

Fixa porta

arreglar puerta. / fix door.

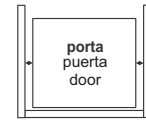

Ajuste de Largura
Ajuste de ancho
Width Adjustment

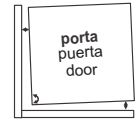

Ajuste Interno
Ajuste Interno
Internal Adjustment

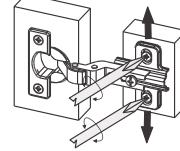

Ajuste de Profundidade
Ajuste de profundidad
Depth Adjustment

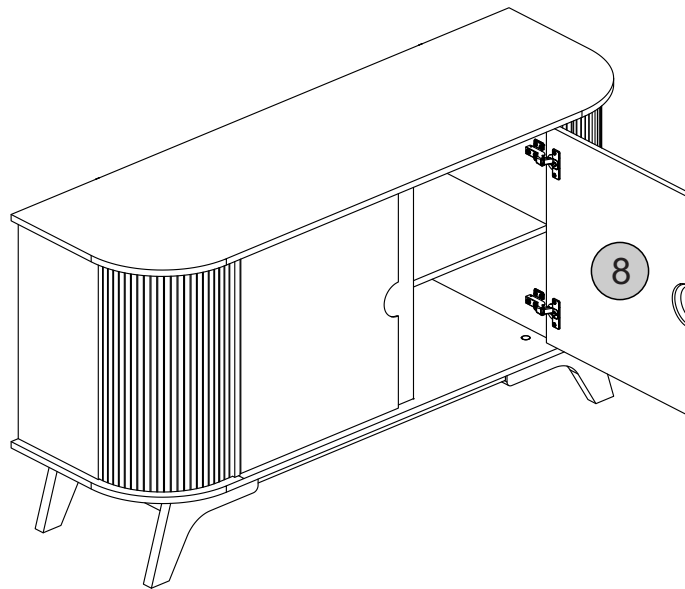

Parabéns, você montou seu móvel! Agora é só decorar sua casa e aproveitar!



Queremos ver como ficou o móvel Artely do seu jeito... Marque a gente com a #meuartely. Ficaremos felizes em compartilhar!

Ah, e se tiver qualquer dúvida, sugestão ou comentário, entra em contato com a gente pelo nosso site www.artely.com.br.

¡Congratulaciones, montaste tu mueble! ¡Ahora solo decora tu casa y disfruta!

Queremos ver este producto en tu hogar, a tu manera... Utilice #meuartely, ¡ficaremos encantados de compartir tu foto!

Si tienes alguna duda, sugerencia o comentario, contáctenos a través de nuestro sitio web www.artely.com.br.

Congratulations, you've assembled your new furniture! Decorate your home and enjoy!

We want to see how this product is in your home... Use #meuartely, we will be happy to share your picture!

If you have any doubt, suggestion or comment, get in touch with us through our website www.artely.com.br.

