

GARANTIA E INSTRUÇÕES DE LIMPEZA E CONSERVAÇÃO

GARANTÍA E INSTRUCCIONES DE LIMPIEZA Y MANTENIMIENTO / WARRANTY AND CLEANING AND CARE INSTRUCTIONS

Nosso produtos são garantidos por 90 dias contra defeitos de fabricação. Ao constatar um problema coberto pela garantia, entre em contato com a loja onde o produto foi comprado. Ela estará capacitada para atendê-lo da melhor forma diante de cada caso. Reclamações de garantia somente poderão ser atendidas se o termo de garantia for apresentado no ato de reivindicação, acompanhado de sua nota fiscal de compra.

Nuestros productos están garantidos contra defectos de fabricación por 90 días, a partir de la compra. Ao constatar un problema protegido por la garantía, póngase en contacto con la tienda donde se adquirió el producto. Ella estará capacitada para atenderlo de la mejor manera de acuerdo con cada caso.

Our products are guaranteed against manufacturing defects for 90 days from the date of purchase. When you find a problem covered by the warranty, please contact the store where the product was purchased. The store be able to serve you in the best way in each case.

Exclusões:

Desgaste natural ou danos causados por água, maresia, ferrugem, incêndio, calor, cupins e pragas em geral. Montagem, manutenção e uso inadequado. Não cumprimento das recomendações técnicas do esquema. Montagens e desmontagens após a primeira instalação. Instalações elétricas e outras afins.

Exclusões:

Desgaste natural o daños causados por agua, niebla salina, óxido, fuego, calor, termitas y plagas en general. Mantenimiento y uso inadecuado. Incumplimiento de las recomendaciones técnicas del esquema. Montaje y desmontaje tras la primera instalación. Instalaciones eléctricas y otras similares.

Exclusões:

Natural wear and tear or damage caused by water, sea spray, rust, fire, heat, termites and pests in general. Improper assembly, maintenance and use. Failure to comply with the technical recommendations of the scheme. Assembly and disassembly after the first installation. Electrical and other related installations.

Para retirar o pó, utilize um pano seco, espanador ou aspirador. Se necessário, para uma limpeza mais efetiva, utilize um pano levemente umedecido com água. Finalize com uma flanela limpa e seca. Evite materiais abrasivos, umidade e calor.

Importante

A Linea Brasil não autoriza nenhuma pessoa, loja ou entidade assumir em seu nome qualquer outra garantia que não conste no certificado. A fabricante reserva-se no direito de efetuar nos produtos eventuais modificações que considerar necessárias, sem prejudicar as características essenciais. Os produtos terão peças de assistência para reposição no período de 1 ano a contar de sua retirada do mercado, desde que haja matéria-prima equivalente, observando o dispositivo no Art.32 da Lei 8.078/90 (Cód. Defesa do Consumidor). O atendimento para produtos fora de linha é feito por programação especial, através da loja revendedora sob aprovação de consulta prévia ao fabricante.

Importante

Linea Brasil no autoriza a ninguna persona, tienda o entidad a asumir en su nombre cualquier otra garantía que no figure en el certificado. El fabricante se reserva el derecho de efectuar en los productos eventuales modificaciones que considere necesarias, sin perjudicar las características esenciales. Los productos tendrán piezas de asistencia para reposición en el período de 1 año a partir de su retirada del mercado. La atención para productos fuera de línea es hecha por programación especial, a través de la tienda revendedora bajo aprobación de consulta previa al fabricante.

Importante

Linea Brasil does not authorize any person, store or entity to assume on its behalf any other warranty that does not appear on the certificate. The manufacturer reserves the right to make in the products any modifications that it considers necessary without prejudice to the essential characteristics. The products will have replacement parts within one year of being withdrawn from the market. The service for off-line products is done by special programming, through the store reseller under prior consultation with the manufacture.

To remove dust, use a dry cloth, duster or vacuum cleaner. If necessary, for more effective cleaning, use a cloth slightly dampened with water. Finish with a clean, dry flannel. Avoid abrasive materials, humidity and heat.

VOLUME	ITEM	PEÇA	DESCRIÇÃO	DIMENSÕES (mm)	QUANTIDADE	MATERIAL
Caja	Artículo	Plaza	Descripción	Dimension	Cantidad	Materia
BOX	Item	Part	Description	Dimension	Amount	
1	1	590463001	BASE BASE BASE	1200 502	15	1 MDF
1	2	590463002	LATERAL ESQUERDA LADO IZQUIERDO LEFT SIDE	678 501	15	1 MDF
1	3	590463003	LATERAL DIREITA LADO DERECHO RIGHT SIDE	678 501	15	1 MDF
1	4	590463004	DIVISAO DIVISION DIVISION	628 501	15	1 MDF
1	5	590463005	PRATELEIRA ESTANTE SHELF	756 430	15	1 MDF
1	6	590463006	FUNDO INFERIOR FONDO INFERIOR LOWER BOTTOM	776 353	2.8	2 MDF
1	7	590463007	FUNDO LATERAL LATERAL FONDO SIDE BOTTOM	678 416	2.8	1 MDF
1	8	590463008	TRAVESSA SUPERIOR BANDEJA SUPERIOR UPPER CROSSBOARD	1667 50	15	2 MDF
1	9	590463009	ENCABECAMENTO TÍTULO HEADING	694 31	18	2 MDF
1	10	590463010	LATERAL ESQUERDA GAVETA MENOR CAJÓN PEQUEÑO DEL LADO IZQUIERDO LEFT SIDE SMALLER DRAWER	400 95	15	2 MDF
1	11	590463011	LATERAL DIREITA GAVETA MENOR CAJÓN PEQUEÑO DEL LADO DERECHO RIGHT SIDE SMALLER DRAWER	400 95	15	2 MDF
1	12	590463012	CONTRA FUNDO GAVETA MENOR CONTRA EL FONDO DEL CAJÓN MÁS PEQUEÑO SMALLER DRAWER COUNTER-BOTTOM	326 93	15	2 MDF
1	13	590463013	LATERAL ESQUERDA GAVETA MAIOR CAJÓN MÁS GRANDE DEL LADO IZQUIERDO LEFT SIDE LARGER DRAWER	400 204	15	1 MDF
1	14	590463014	LATERAL DIREITA GAVETA MAIOR CAJÓN MÁS GRANDE DEL LADO DERECHO RIGHT SIDE LARGER DRAWER	400 204	15	1 MDF
1	15	590463015	CONTRA FUNDO GAVETA MAIOR FONDO CAJÓN MÁS GRANDE LARGER DRAWER COUNTER-BOTTOM	326 202	15	1 MDF
1	16	590463016	FUNDO GAVETA FONDO DEL CAJÓN DRAWER BOTTOM	395 336	2.8	3 MDF
1	17	590463017	FRENTE GAVETA SUPERIOR CAJÓN SUPERIOR DELANTERO UPPER DRAWER FRONT	376 148	15	1 MDF
1	18	590463018	FRENTE GAVETA CENTRAL CAJÓN CENTRAL DELANTERO CENTRAL DRAWER FRONT	376 160	15	1 MDF
1	19	590463019	FRENTE GAVETA INFERIOR CAJÓN INFERIOR DELANTERO LOWER DRAWER FRONT	376 383	15	1 MDF
1	20	590463020	PORTA DIREITA PUERTA DERECHA RIGHT DOOR	664 375	15	1 MDF
1	21	590463021	PORTA ESQUERDA PUERTA IZQUIERDA LEFT DOOR	664 375	15	1 MDF
1	22	590463022	BATENTE GAVETA TOPE DEL CAJÓN DRAWER STOPPER	396 70	15	1 MDF
1	23	590463023	APOIO GAVETA SUPORTE DE CAJÓN DRAWER SUPPORT	366 86	15	1 MDF
1	24	590463024	DISTANCIADOR GAVETA DISTANCIADOR DE CAJONES DRAWER SPACER	360 70	15	3 MDF
1	25	590464001	TAMPO (OPCIONAL) ARRIBA (OPCIONAL) TABLET (OPTIONAL)	1200 521	30	1 MDF
1	26	590463026	FUNDO SUPERIOR ARRIBA ABAJO UPPER BOTTOM	776 336	2.8	1 MDF

TABELA DE ACESSÓRIOS | TABLA DE ACCESÓRIOS | ACCESSORIES TABLE

Código Code	Descrição Description Description	Quantidade Amount
A 90001002	PRENDEDOR DE FUNDOS ABRAZADERA INFERIOR BOTTOM CLAMP	15
B 90001003	CAVILHAS 8X20MM TACOS 8X20MM DOWELS 8X20MM	6
C 90001004	CAVILHAS 8X30MM TACOS 8X30MM DOWELS 8X30MM	22
D 90001009	ARRUELA 3/16 ARANDELA 3/16 WASHER 3/16	2
E 90001024	PINO GIROFIX PIN GIROFIX GIRLOFIX PIN	24
F 90001025	CASTANHA DO MINI-GIROFIX TUERCA MINI-GIROFIX MINI-GIROFIX HANDLE	24
G 90001061	SUPORTE ANGULAR CENTRAL SOPORTE ANGULADO CENTRAL CENTRAL ANGLE SUPPORT	8
H 90001062	CANTONERA PLÁSTICA ESQUINA DE PLÁSTICO PLASTIC CORNER	10
I 90002002	TAMPA ADESIVA CUBIERTA ADHESIVA ADHESIVE COVER	12
J 90002006	BUCHA COINETE BUSH	2
K 90002012	GIZ DE CORRECAO TIZA DE CORRECCIÓN CORRECTION CHALK	2
L 90002014	DISTANCIADOR DE PAINEL DISTANCIADOR DE PANEL PANEL SPACER	2
M 90002015	BATENTE SILICONE TOPE DE SILICONA SILICONE STOPPER	12
N 90002022	TAMPA ADESIVA 12MM CUBIERTA ADHESIVA 12MM ADHESIVE COVER 12MM	12
O 90003014	DOBRADICA 39MM BAIXA + CALCO BISAGRA BAJA 39MM LOW HINGE 39MM	2
P 90003016	DOBRADICA 39MM SUPER CURVA + CALCO BISAGRA SUPER CURVA 39MM SUPER CURVED HINGE 39MM	2
Q 90006001	PARAFUSO 3.5X12 CABECA CHATA TORNILLO CABEZA PLANA 3.5X12 SCREW 3.5X12 FLAT HEAD	36
R 90006006	PARAFUSO 3.5X40 CABECA CHATA TORNILLO 3.5X40 CABEZA PLANA SCREW 3.5X40 FLAT HEAD	16
S 90006008	PARAFUSO 4.5X25 CABECA CHATA TORNILLO 4.5X25 CABEZA PLANA SCREW 4.5X25 FLAT HEAD	8
T 90006010	PARAFUSO 4.5X30 CABECA CHATA TORNILLO 4.5X30 CABEZA PLANA SCREW 4.5X30 FLAT HEAD	5
U 90006011	PREGO 8X8 COM CABECA LISO CLAVO 8X8 CON CABEZA LISA SMOOTH HEAD NAIL 8X8	40
V 90006015	PARAFUSO 6.0X75 CABECA CHATA TORNILLO 6.0X75 CABEZA PLANA SCREW 6.0X75 FLAT HEAD	2
W 90006016	PARAFUSO 3.5X12 CABECA FLANGEADA TORNILLO 3.5X12 CABEZA BRIDA SCREW 3.5X12 FLANGED HEAD	63
X 90006042	PARAFUSO 3.5X30 CABECA FLANGEADA TORNILLO 3.5X30 CABEZA BRIDA SCREW 3.5X30 FLANGED HEAD	4
Y 90008006	CORREDICA TELESCÓPICA 350MM CORREDERA TELESCÓPICA 350MM TELESCOPIC SLIDE 350MM	3
Z 90009047	PE PLÁSTICO RETANGULAR PE PLÁSTICO RECTANGULAR RECTANGULAR PE PLASTIC	5
AA 90009048	ORGANIZADOR DE TALHERES ORGANIZADOR DE CUBIERTOS CUTLERY ORGANIZER	1

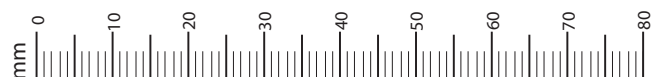

01

- C 18x
- H 04x
- L 02x
- Q 09x
- S 02x
- W 04x
- Y 03x

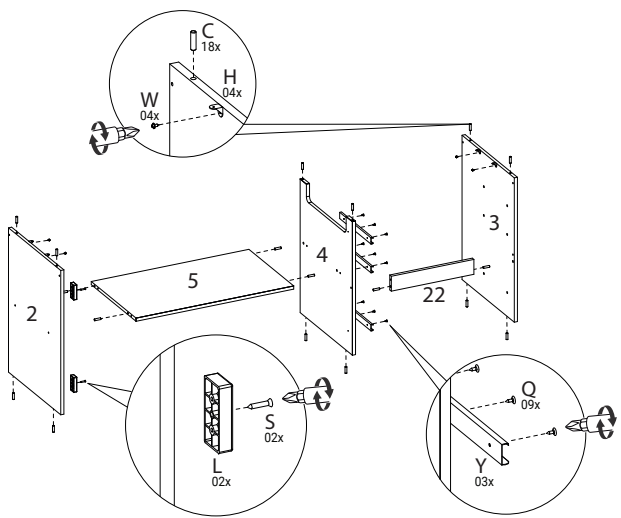

02

- N 02x
- R 04x

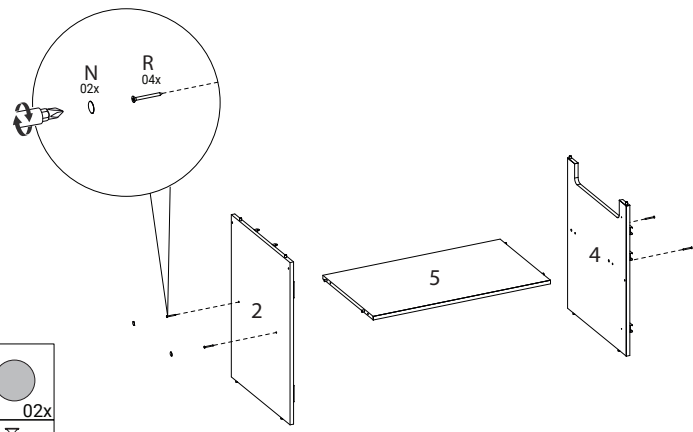

03

- H 06x
- N 06x
- R 06x
- W 08x

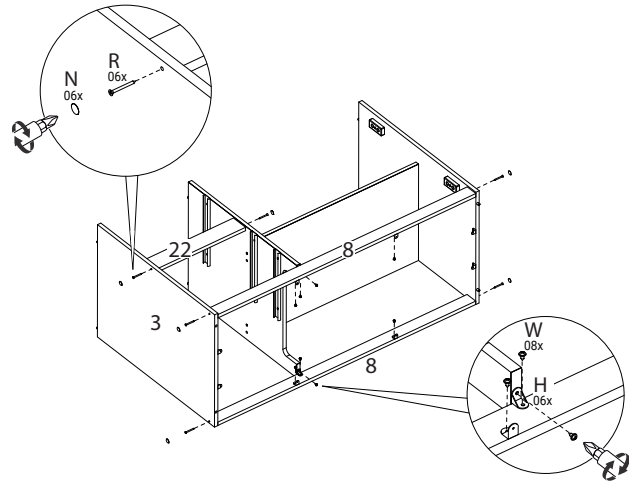

04

- R 06x

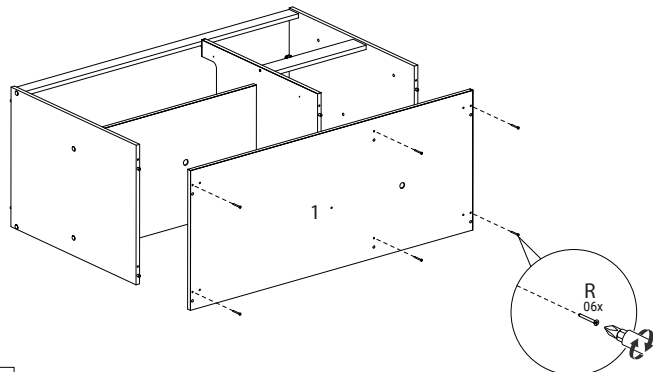

05

- N 03x
- T 05x
- W 05x
- Z 05x

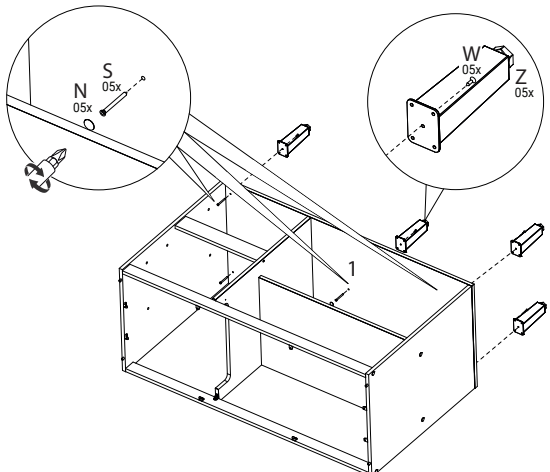

06

- B 06x
- S 06x

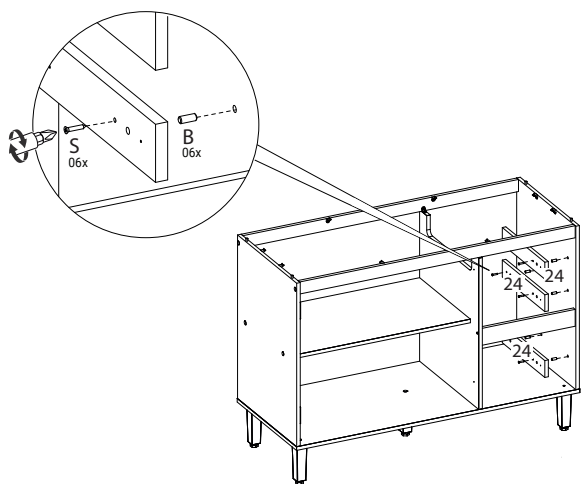

07

- G 08x
- Q 09x
- W 16x
- Y 03x

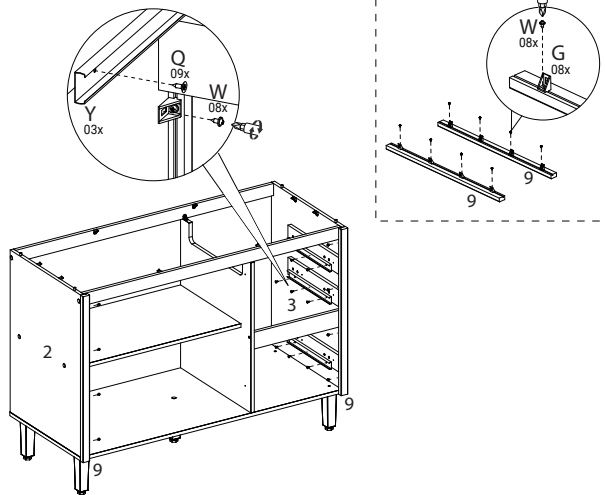

08

- A 15x
- W 06x
- U 40x

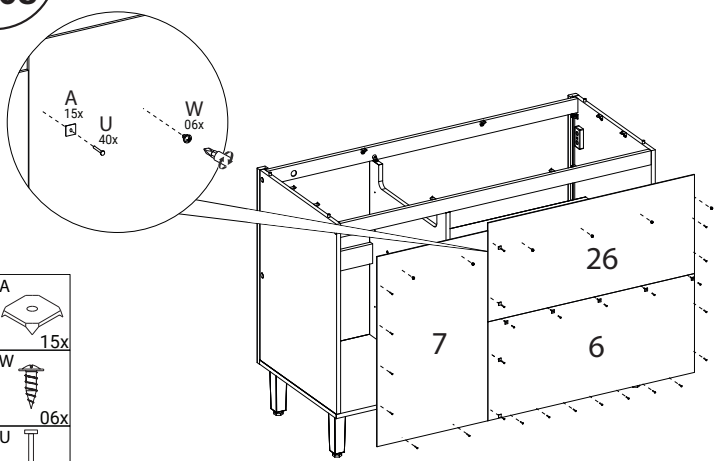

09

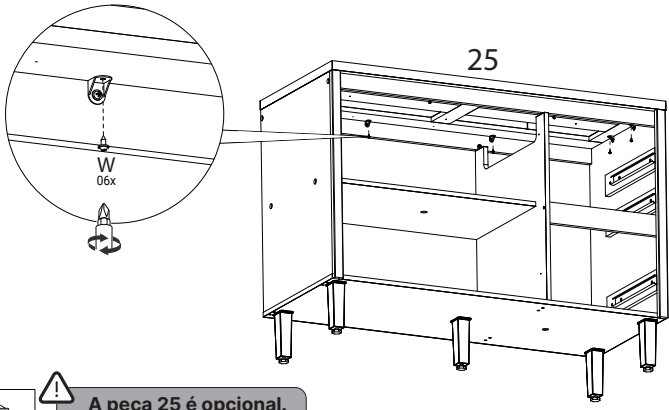

A peça 25 é opcional.
 La pieza 25 es opcional.
 The piece 25 is optional.

10

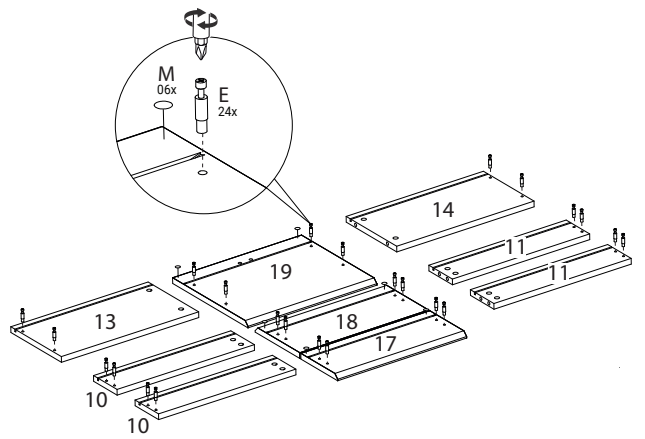

11

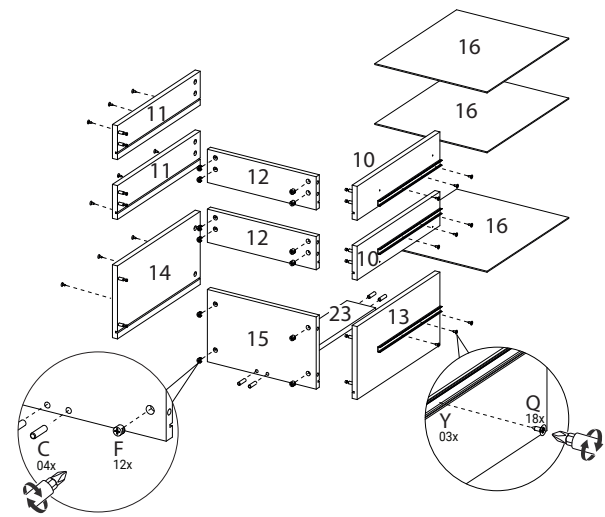

12

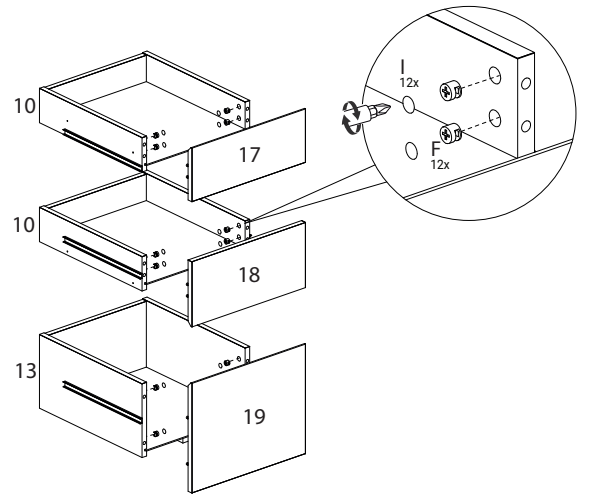

13

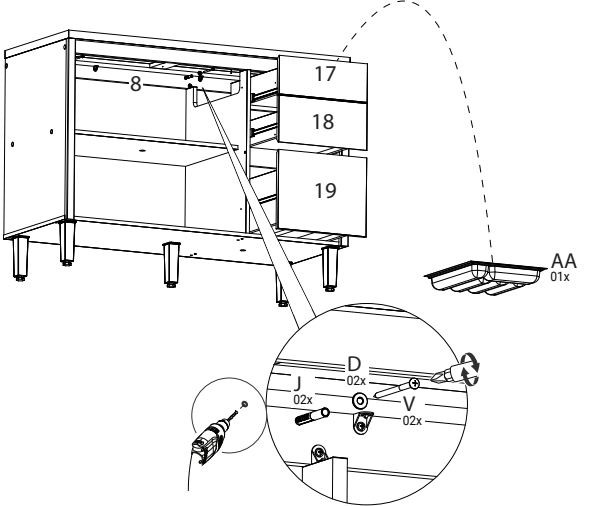

14

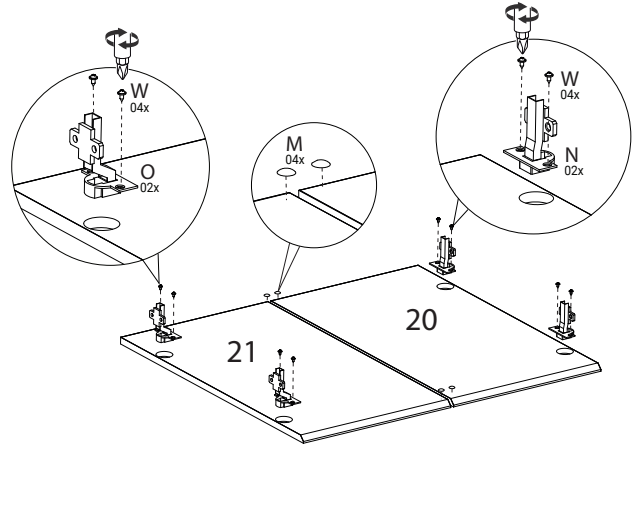

15

