

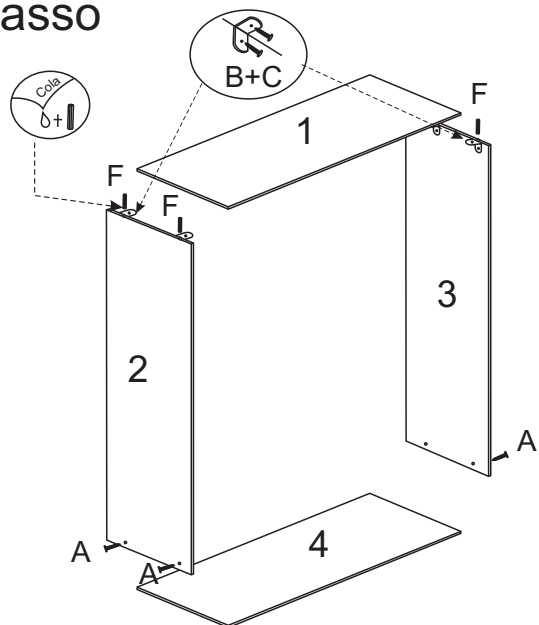

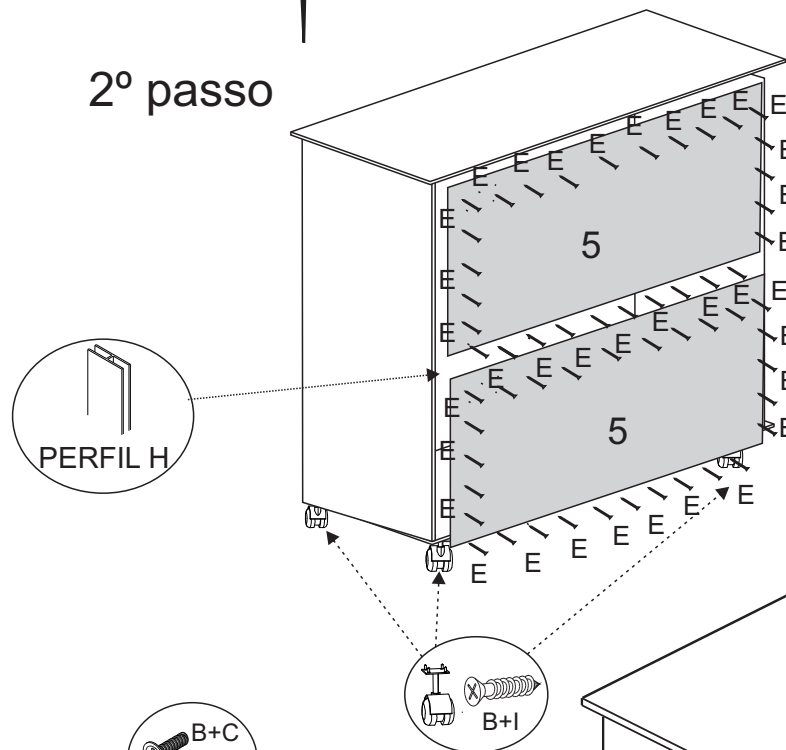





**1º passo**



**2º passo**

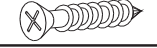
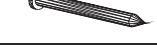

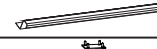
**FERRAGENS**

6	A		Parafuso 4 x 40
52	B		Parafuso 3,5 x 14
6	C		Cantoneira Fixador 18x18
6	D		Parafuso 3,5 x 25
25	E		Prego 10 x 10
12	F		Cavilhas 6 x 30
4	G		Dobradiças
2	H		Corrediça
4	I		Rodízio

**3º passo**

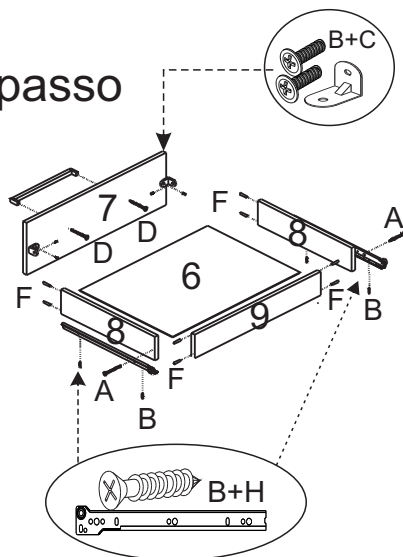

**4º passo**

