

### Balcão Pia 02 Gavetas 03 Portas Connect

Pia Contador 02 Cajones 03 Puertas Connect | Balcony Pia 02 Drawers 03 Doors Connect

C66-35 Duna/Cristal | C66-42 Fendi

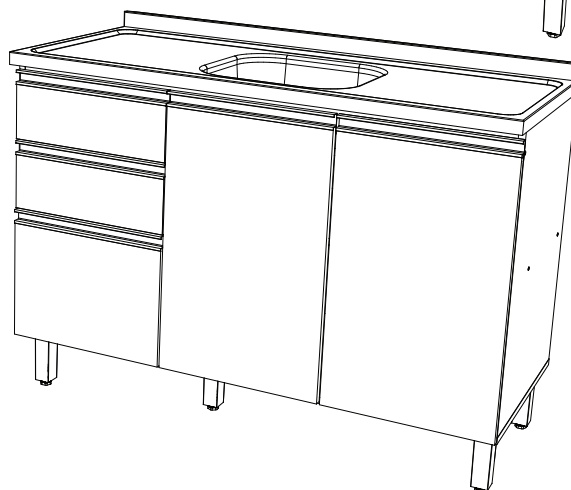
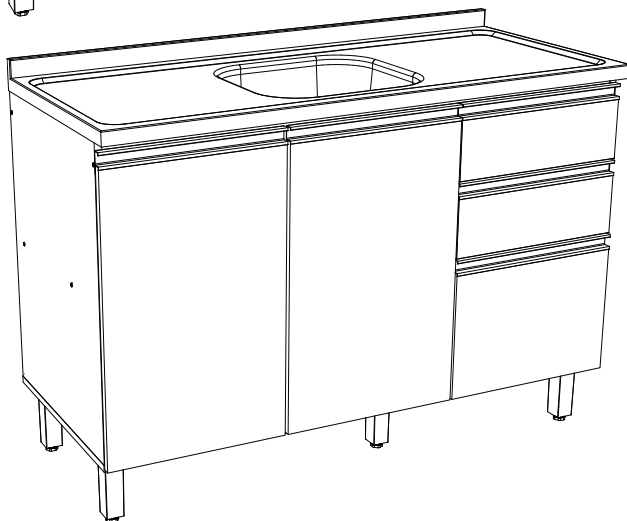
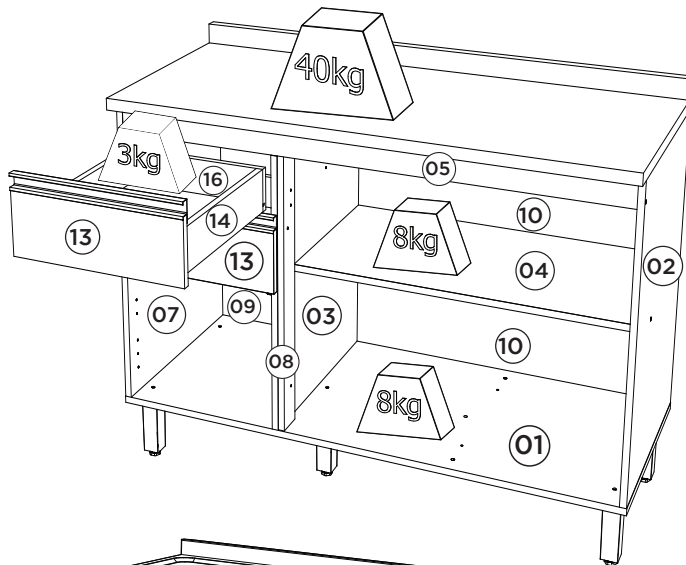
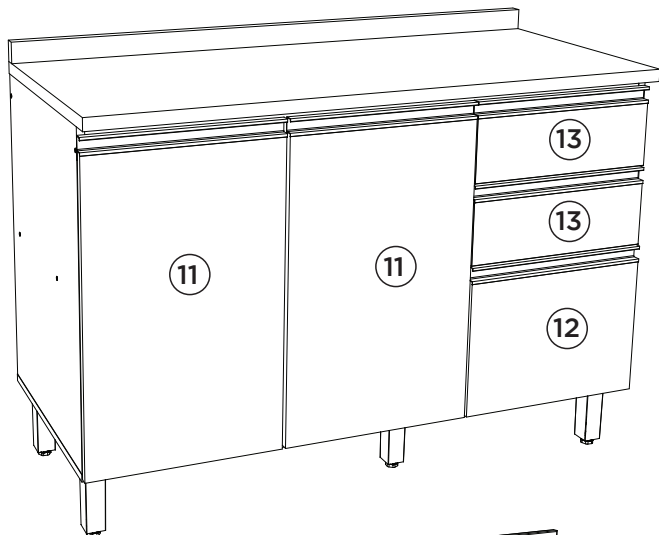

**Pesos máximos recomendados com carga distribuída**  
**Peso máximo recomendado con la carga distribuida**  
**Recommended maximum weights with evenly distributed.**

**Requisitos para montagem**  
**Requisitos para la montaje**  
**Assembly Requirements**

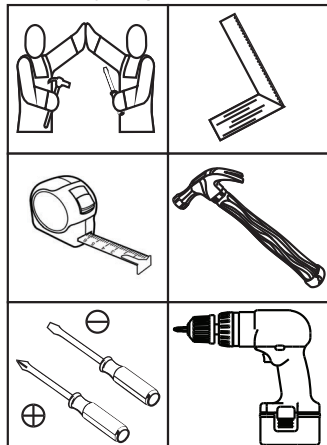

Imagens meramente ilustrativas, não acompanha o produto.  
Imágenes ilustrativas, no incluidas con el producto.  
Illustrative images, not included with the product.

**AVISO**

Para limpeza de seu móvel, use uma flanela seca ou umedecida, e não utilize produtos químicos que possam danificar seu produto.

**SISTEMA DE MONTAGEM**

O sistema de montagem dos produtos, funciona de acordo com a ordem crescente dos números indicados no desenho. Ex: 01, 02, 03, 04... até a conclusão da montagem.

**ASSISTÊNCIA TÉCNICA**

Para solicitação de Assistência Técnica você consumidor deverá entrar em contato com o Lojista o qual você realizou a compra deste produto e solicitar a assistência técnica das peças avariadas. A garantia abrange todas as peças, partes e componentes que eventualmente venham apresentar defeito de fabricação no prazo de 03 (três) meses, contando a partir da entrega do produto ao consumidor, mediante nota fiscal de compra. Se houver qualquer alteração na estrutura do produto ou ocorrer defeito por negligência do montador/consumidor em relação a instrução de montagem e manuseio, não será fornecido assistência técnica gratuita.

**ADVERTENCIA**

Para limpieza de su móvil, use una flanela seca o húmeda, y no utilice productos químicos que puedan dañar su producto.

**SISTEMA DE MONTAJE**

El sistema de montaje de los productos funciona de acuerdo con el orden creciente de los números indicados en el dibujo. Ej.: 01, 02, 03, 04... hasta la conclusión del montaje.

**ASISTENCIA TÉCNICA**

Para solicitar Asistencia Técnica, el consumidor debe comunicarse con el Comercio que usted realizó la compra de este producto y solicita asistencia técnica para las partes dañadas. La garantía cubre todas las partes, piezas y componentes que eventualmente puedan presentar defecto de fabricación en el plazo de 03 (tres) meses, contados a partir de la entrega del producto al consumidor, mediante factura de compra. Si se produce algún cambio en la estructura del producto o se produce un defecto por negligencia del montador/consumidor en relación con las instrucciones de montaje y manipulación, no se prestará asistencia técnica gratuita.

**NOTICE**

To clean your furniture, use a dry or wet cloth, and do not use chemicals that may damage your product.

**ASSEMBLY SYSTEM**

The products' assembly system works according to the increasing order of the indicated numbers. For example: 01, 02, 03, 04 ... to the end of the assembly.

**TECHNICAL ASSISTANCE**

To request Technical Assistance, the consumer must contact the retailer from whom you purchased this product and request technical assistance for the damaged parts. The warranty covers all parts, parts and components that may eventually present a manufacturing defect within a period of 03 (three) months, counting from the delivery of the product to the consumer, by means of a purchase invoice. If there is any change in the structure of the product or defect occurs due to negligence of the assembler/consumer in relation to the assembly and handling instruction, free technical assistance will not be provided.

1º

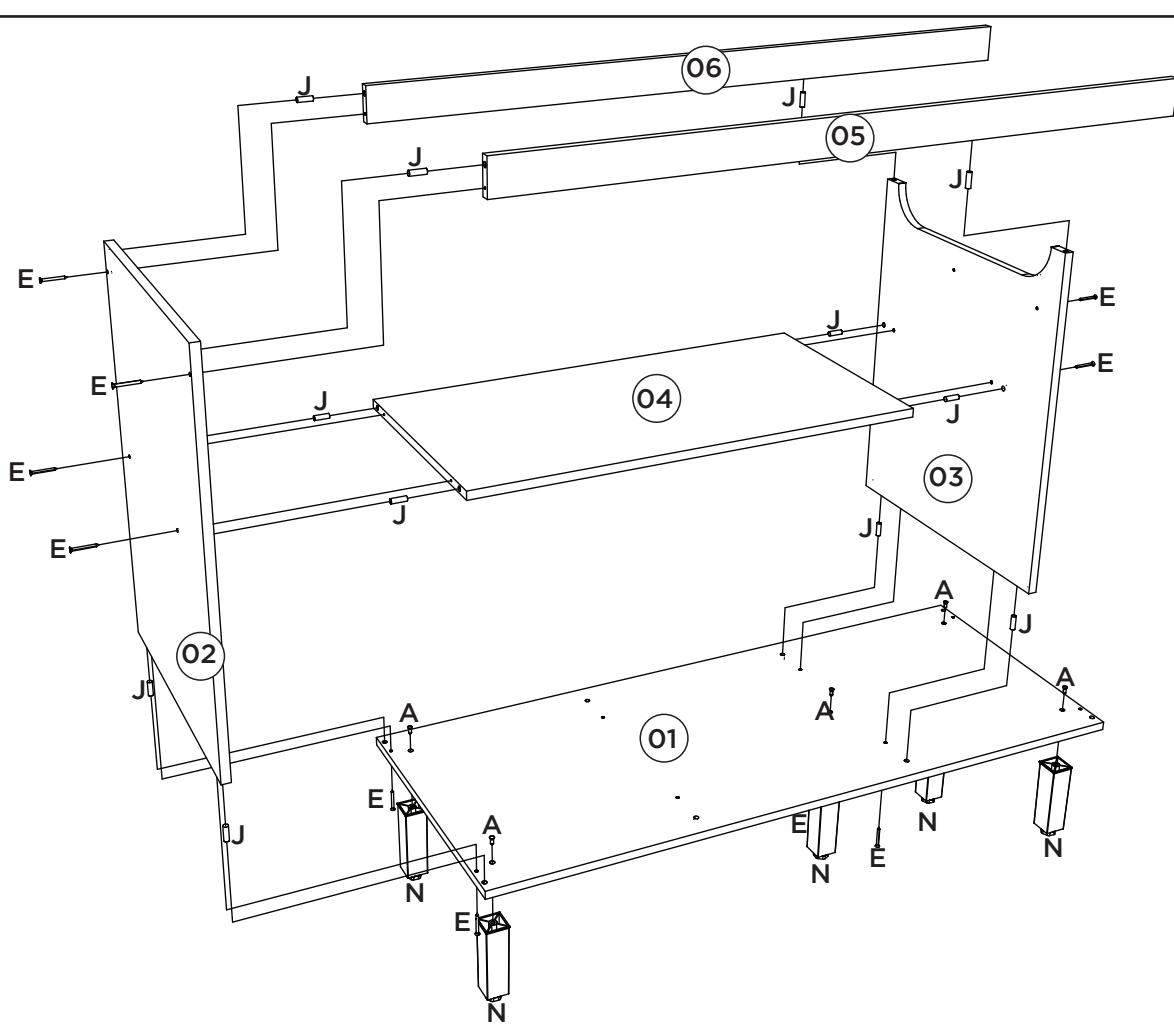

2º

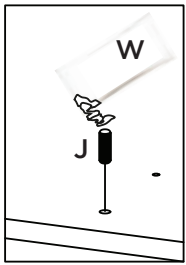

Utilizar o sachê de cola (W) em todas as cavilhas (J) do produto.

Con el pegamento sobre (W) en todos los pernos (J) producto.

Use the glue sachet (W) on all the pegs (J) of the product.

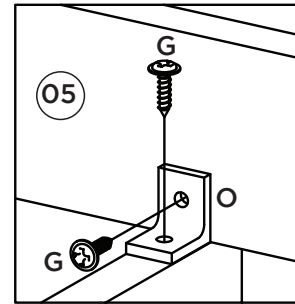

A pilastra da porta (08) deve estar alinhada com a divisão (03).

El pilar de la puerta (08) debe estar alineada con la división (03).

The door pillar (08) must be aligned with the partition (03).

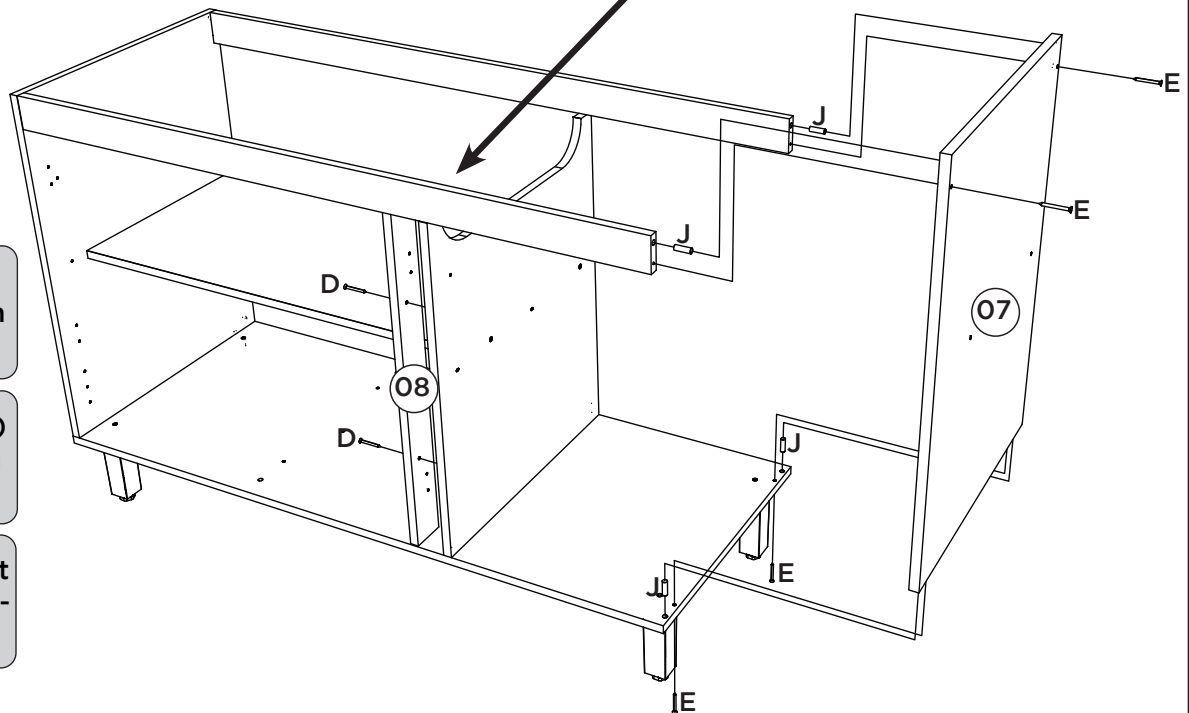

3º

Esse tampo é opcional e é vendido separadamente (C905-33).

Esta vez es opcional y se vende por separado (C905-33).

This top is optional and is sold separately (C905-33).

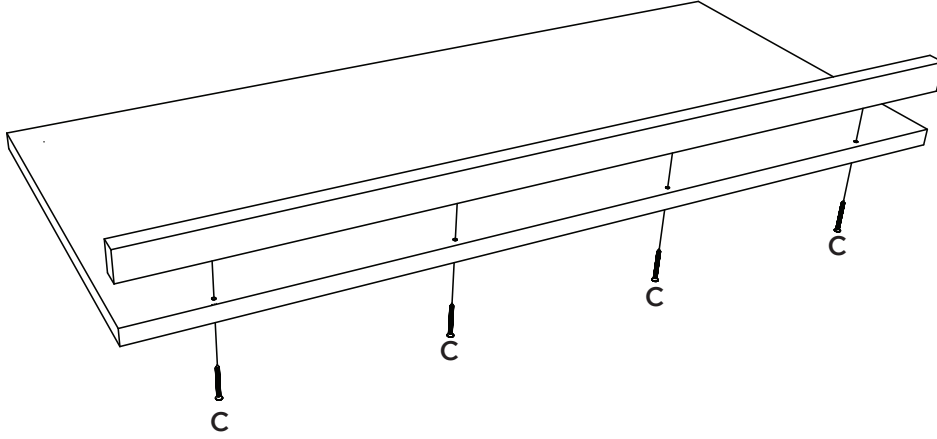

4º

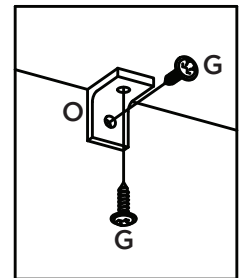
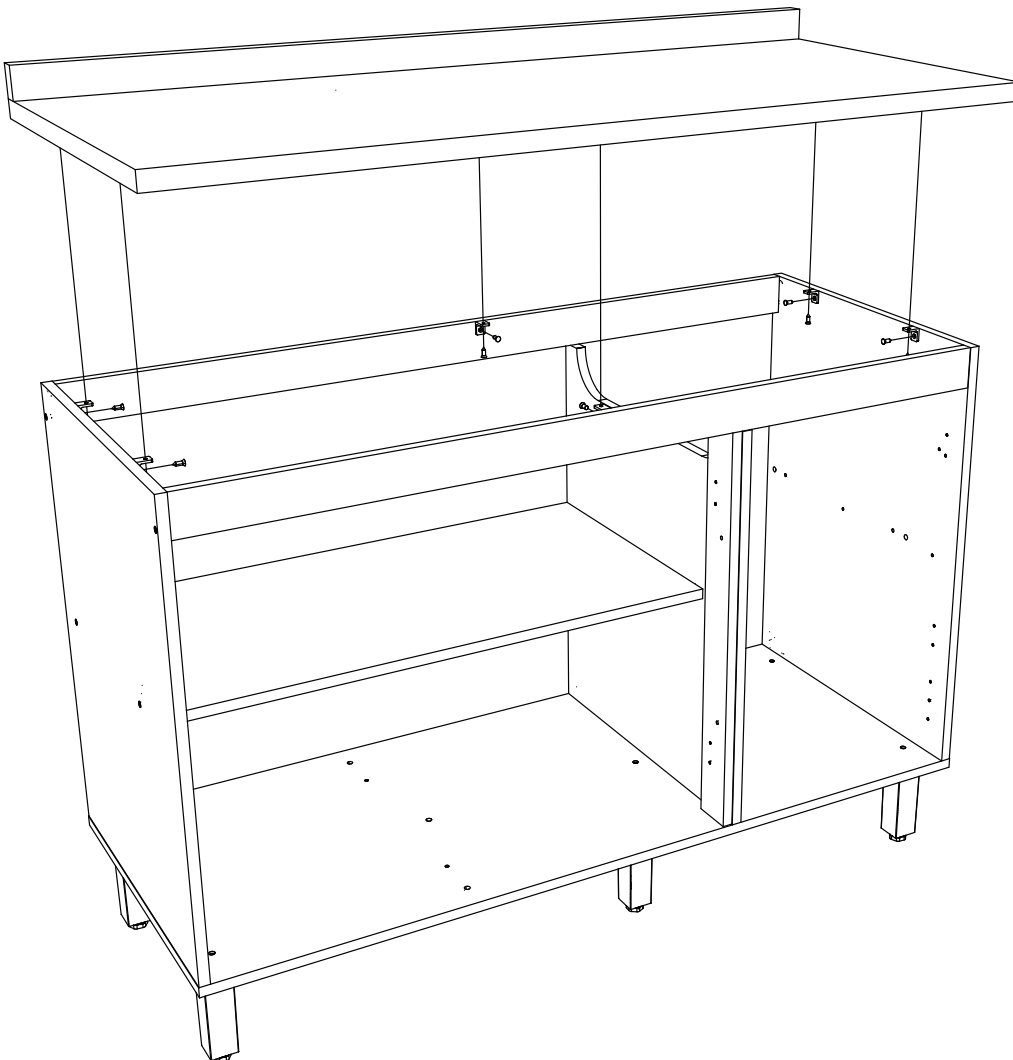

Caso o móvel seja montado com a opção do tampo, fixar o mesmo com 06 cantoneiras (O) e os parafusos 3,5x14mm (G).

Si se monta el auricular con la opción de la cubierta, fijarlo con Los ángulos 06 (O) y 3,5 x14mm tornillos (G).

If the furniture is to be installed with the top cover option, fix it with 06 (O) and 3.5x14mm screws (G).

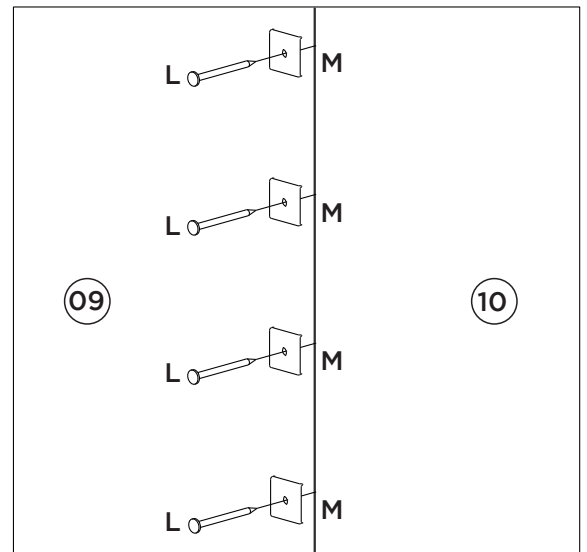
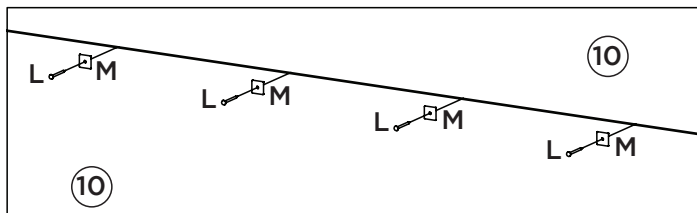
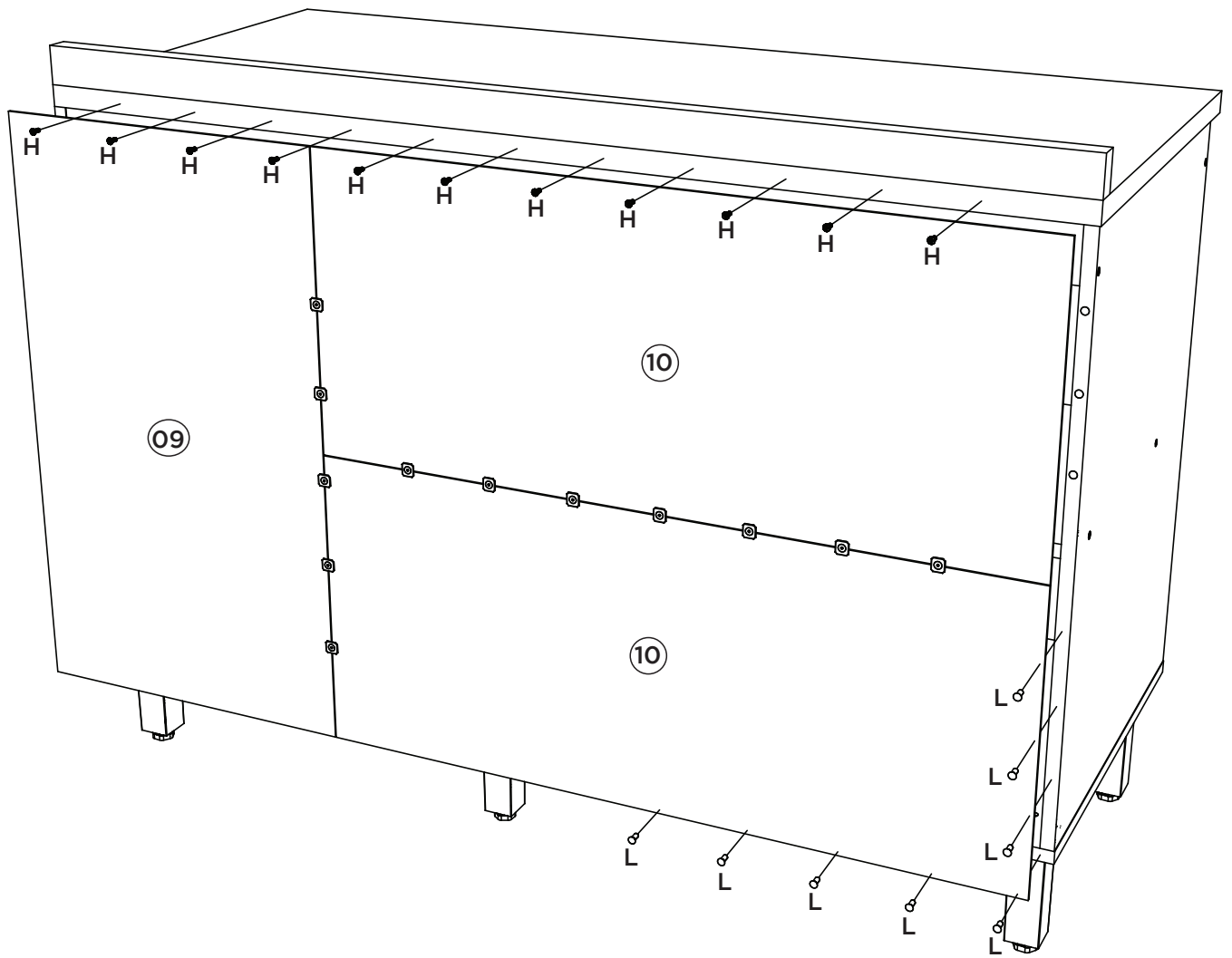

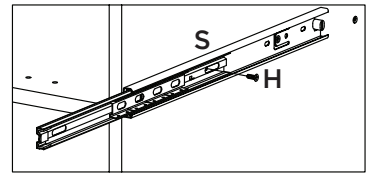
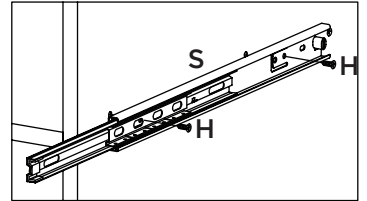
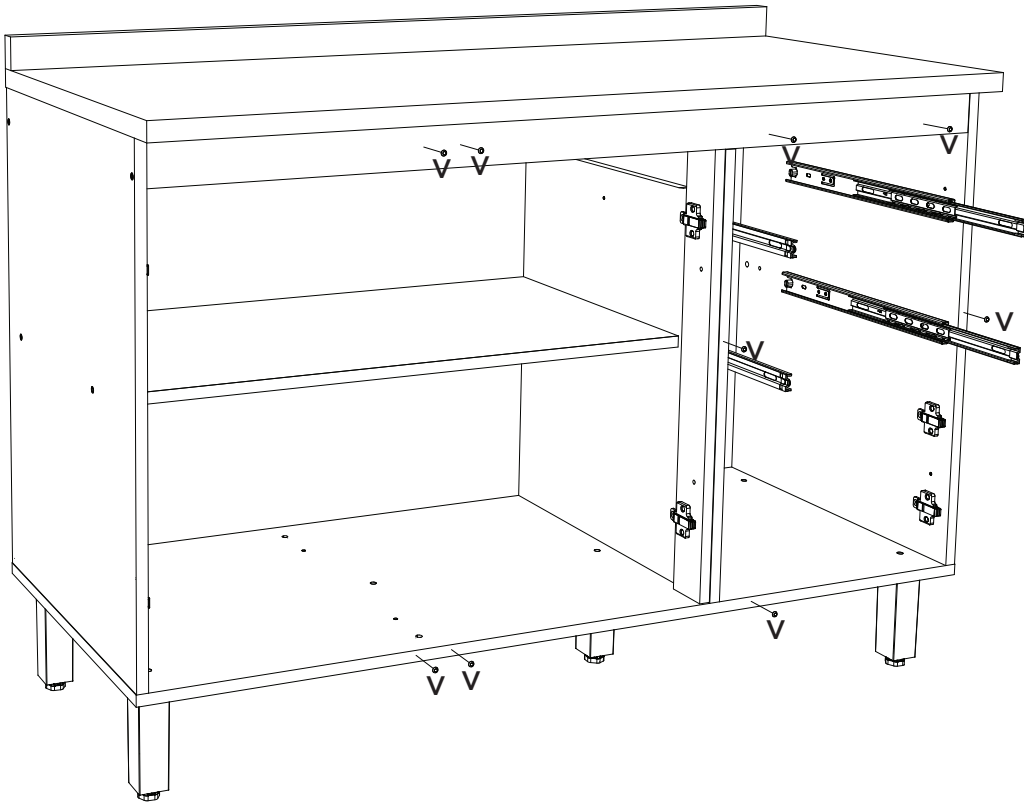

Fixação da corredeira telescópica (S).

Fijación Slide telescópico (S).

Fixing of the telescopic slide (S).

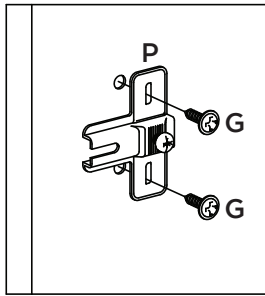

Fixação do calço 5mm (P).

Montaje de la placa de 5mm (P).

Shim fixation 5mm (P).

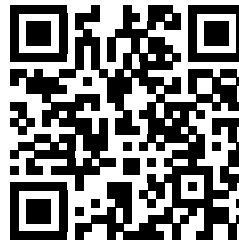

Vídeo: Dicas para fixar a Corredeira

Video: Consejos para arreglar la diapositiva

Video: Tips for Fixing the Slide

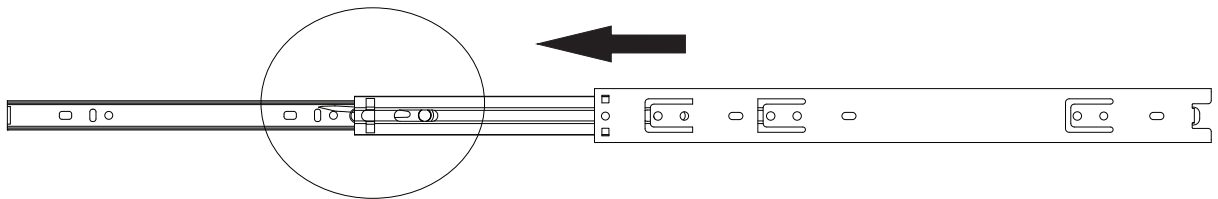

Para a desmontagem da corredeira siga a instrução ao lado.

Para el desmontaje seguimiento de diapositivas la instrucción siguiente a.

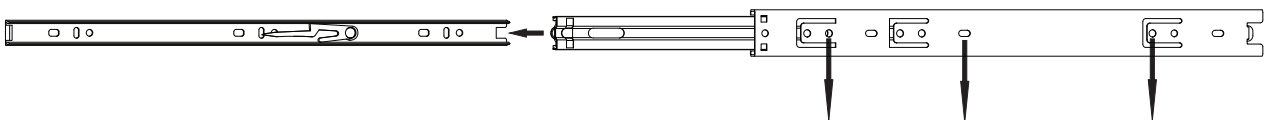
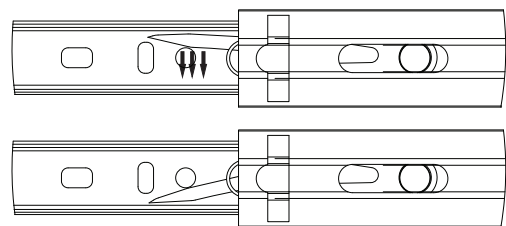

Fixar as corredeiras nessas furações

Fijar las diapositivas de estos agujeros



Vídeo: Instalar e regular Dobradiças

Vídeo: Instale y ajuste las bisagras

Video: Install and adjust hinges

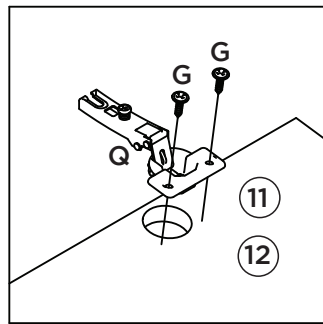

Fixação da dobradiça (Q).

La fijación de la bisagra (Q).

Hinge fixing (Q).

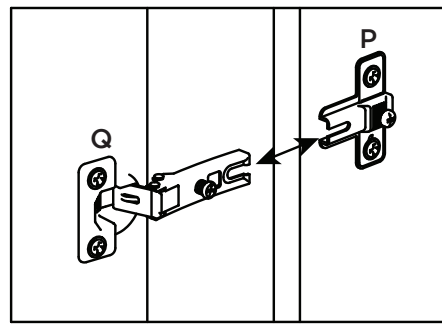

Encaixe da dobradiça (Q) com o calço (P).

Fije la bisagra (Q) con cuña (P).

Hinge fitting (Q) with shim (P).

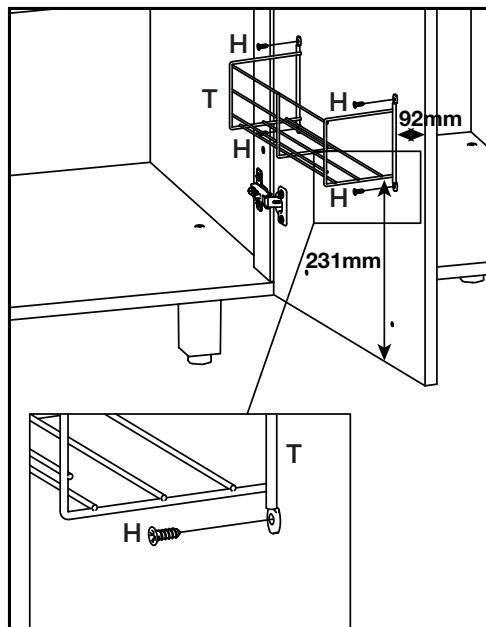
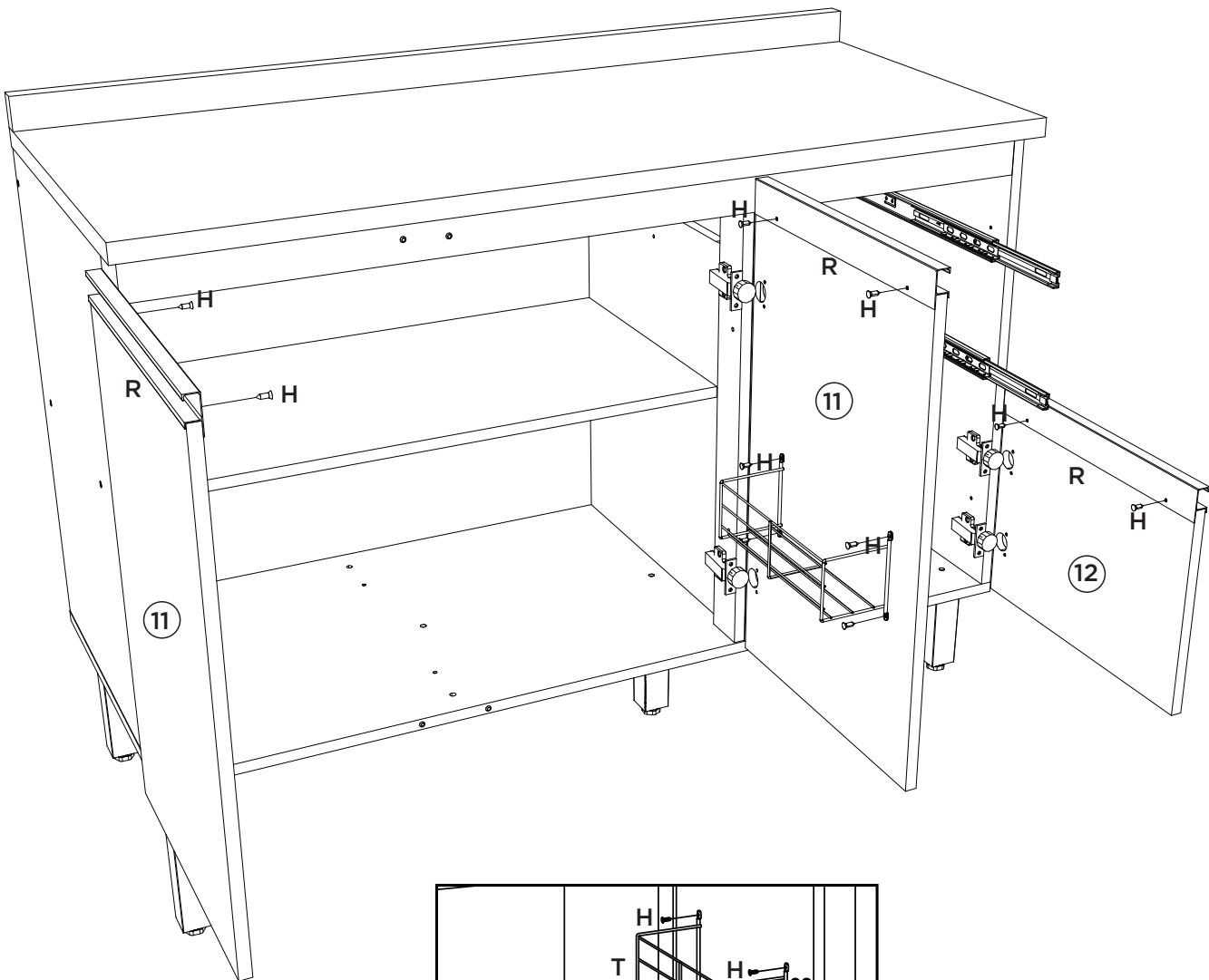

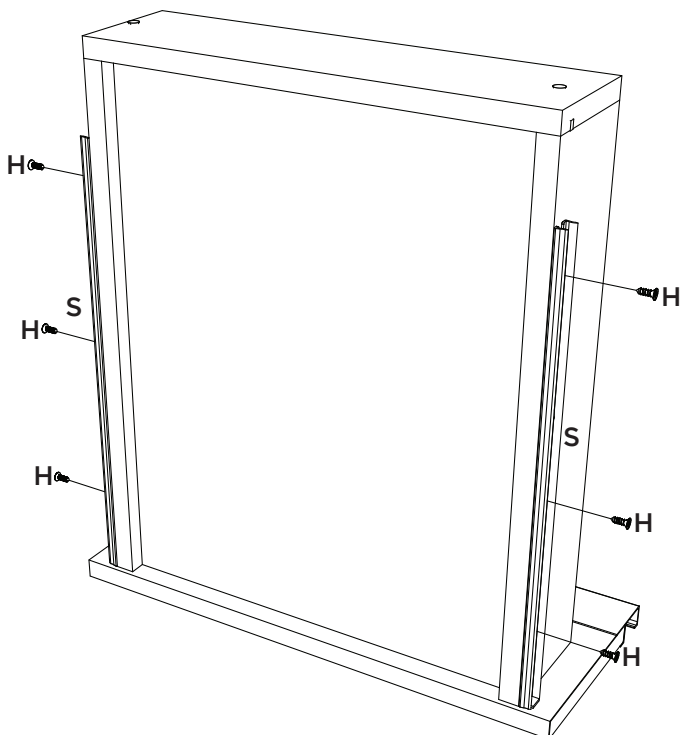
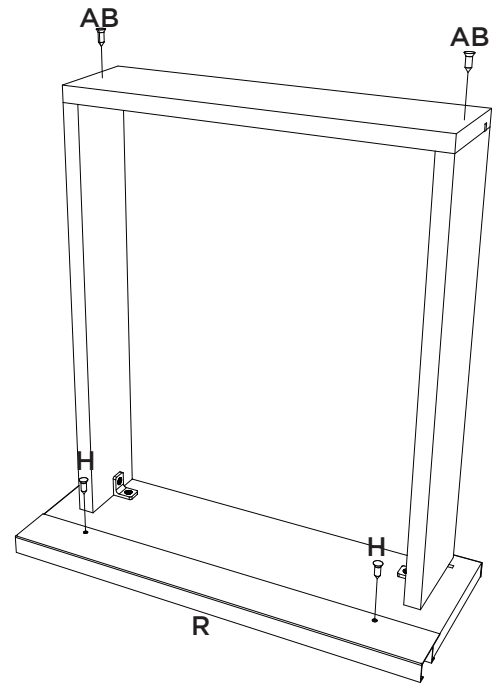
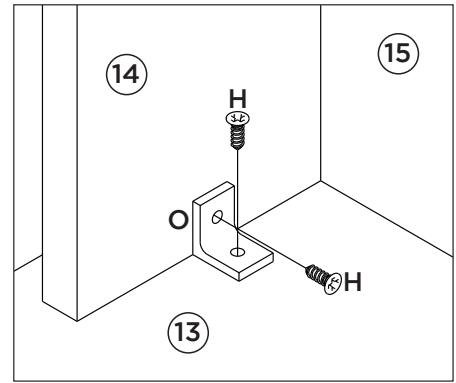
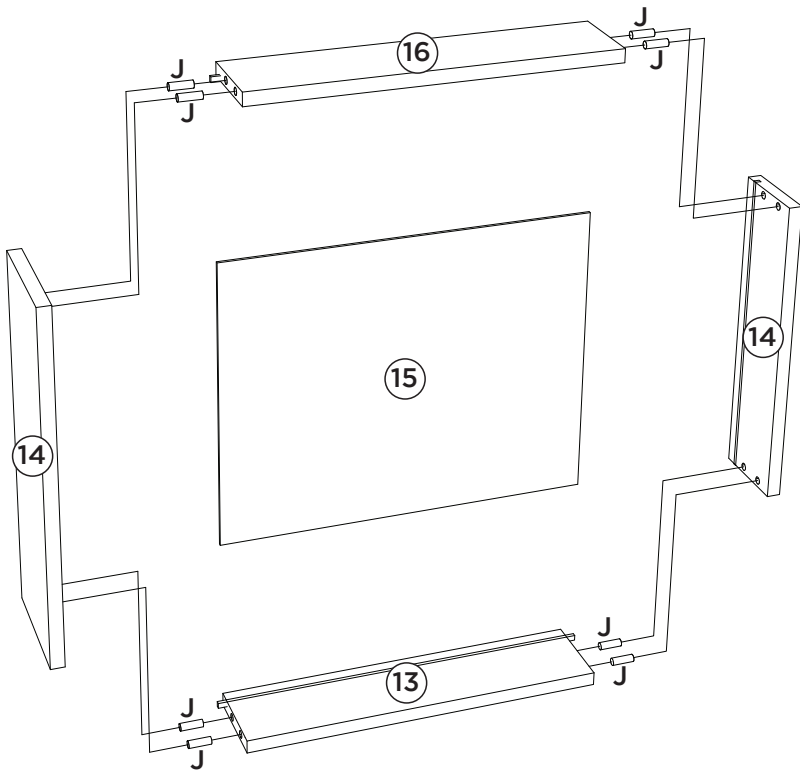











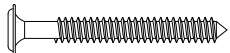



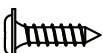



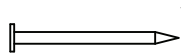

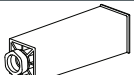



A corrediça (S) deverá ser alinhada com a parte de baixo do lado de gaveta (14).

La carcasa (S) será alineada con la parte de por el lado del cajón (14).

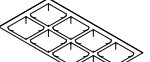
The slide (S) should be aligned with the underside of the drawer side (14).

Item	Caixa Caja Box	Qtd Ctd Qty	Descrição   Descripción   Description	Medidas (mm)   Dimensions (mm)   Size (measurements) (mm)
01	1/1	01	Base   Base   Base	1200x490x15
02	1/1	01	Lateral esquerda   Lateral izquierda   Left side	660x490x15
03	1/1	01	Divisão   División   Division	600x490x15
04	1/1	01	Prateleira   Estante   Shelf	783x400x15
05	1/1	01	Travessa frontal   Travesaño frontal   Front crossbar	1168x60x15
06	1/1	01	Travessa traseira   Travesaño trasero   Rear bumper	1168x60x15
07	1/1	01	Lateral direita   Lateral derecha   Right side	660x490x15
08	1/1	01	Pilastra da Porta   Pilastra Puerta   Pilaster door	599x60x15
09	1/1	01	Fundo menor   Fondo menor   Minor fund	683x389x3
10	1/1	02	Fundo   Fondo   Bottom	802x341x3
11	1/1	02	Porta   Puerta   Door	625x396x15
12	1/1	01	Porta menor   Puerta menor   Smaller door	396x290x15
13	1/1	02	Frente de gaveta   Frente de cajón   Front of drawer	396x136x15
14	1/1	04	Lado de Gaveta menor   Lado del cajón menor   Smallest Drawer Side	400x90x15
15	1/1	02	Fundo de gaveta   Fondo de cajón   Bottom of drawer	411x326x3
16	1/1	02	Ripa de trás   Malla detrás   Rear lath	345x90x15

Ferragens | Herrajes | Hardware

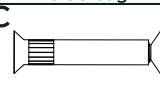
<b>A</b>  Parafuso 7,0x40mm CHT. Tornillo 7,0x40mm CHT. Screw 7,0x40mm CHT.	<b>B</b>  Parafuso 5,0x50mm FLA. Tornillo 5,0x50mm FLA. Screw 5,0x50mm FLA.	<b>C</b>  Parafuso 4,5x50mm CHT. Tornillo 4,5x50mm CHT. Screw 4,5x50mm CHT.	<b>D</b>  Parafuso 4,0x25mm CHT. Tornillo 4,0x25mm CHT. Screw 4,0x25mm CHT.	<b>E</b>  Parafuso 3,5x40mm CHT. Tornillo 3,5x40mm CHT. Screw 3,5x40mm CHT.	<b>F</b>  Divisor talheres 398x313mm Divisor cubiertos 398x313mm Cutlery divider 398x313mm
<b>G</b>  Parafuso 3,5x14mm FLA. Tornillo 3,5x14mm FLA. Screw 3,5x14mm FLA.	<b>H</b>  Parafuso 3,5x12mm CHT. Tornillo 3,5x12mm CHT. Screw 3,5x12mm CHT.	<b>I</b>  Giz de correção Tiza de corrección Chalk of correction	<b>J</b>  Cavilha 8x25mm Cinta 8x25mm Dowel 8x25mm	<b>K</b>  Etiqueta resinada Henn Etiqueta resinada Henn Henn resin label	<b>L</b>  Prego 10x10mm Clavo 10x10mm Nail 10x10mm
<b>M</b>  Fixador de fundos Fijador de fondos Bottom fixer	<b>N</b>  Pé 145mm x 42mm Pie 145mm x 42mm Foot 145mm x 42mm	<b>O</b>  Cantoneira plástica Cantonera plástica Plastic angle brackets	<b>P</b>  Calço metal médio 0mm Calzado metálico medio 0mm Metal shim 0mm	<b>Q</b>  Dobradiça metal Baixa 35mm Bisagra metálica Baja 35mm Metal hinge Low 35mm	<b>R</b>  Puxador MOV 396mm Tirador MOV 396mm MOV 396mm Handle
<b>S</b>  Corrediza telescópica Diapositivas telescópicas Telescopic slides	<b>T</b>  Porta detergente 256x91mm Puerta detergente 256x91mm Detergent door 256x91mm	<b>U</b>  Bucha plástica 8mm Bucha de plástico 8mm 8mm plastic bushing	<b>V</b>  Batente PVC para Porta Parada de PVC para Puerta PVC Door Stop	<b>W</b>  Sachê de cola Bolsa de pegamento Glue bag	<b>X</b>  Adesivo tapa parafuso 17mm Adhesivo tapón de tornillo 17mm Bolt cover adhesive 17mm
<b>Y</b>  Suporte de fixação Soporte de fijación Mounting bracket	<b>Z</b>  Proteção para cantoneira Ángulo de protección Protection angle	<b>AA</b>  Adesivo tapa parafuso 10mm Adhesivo tapón de tornillo 10mm Bolt cover adhesive 10mm	<b>AB</b>  Parafuso 3,0x30mm CHT. Tornillo 3,0x30mm CHT. Screw 3,0x30mm CHT.	<b>AC</b>  Parafuso União 30mm Tornillo Unión 30mm Union Screw 30mm	



O parafuso (AC) deve ser usada somente quando este módulo for acoplado a outro módulo componível Henn.

RECOMENDAÇÃO

Para fixar o móvel na parede usar o suporte de fixação (Y), o parafuso 3,5x14mm FLA (G), a Bucha 8mm (U) e o parafuso 5,0x50mm FLA (B).



El tornillo (AC) se debe utilizar sólo cuando el módulo está conectado a otro módulo componible Henn.

RECOMENDACIÓN

Para conectar el móvil a la pared con el soporte (Y), tornillo 3,5 x14mm FLA (G), el casquillo de 8 mm (U) y el 5,0 x50mm tornillo FLA (B).



The screw (AC) should be used only when this module is attached to another Henn modular module.

RECOMMENDATION

To fix the furniture to the wall use the mounting bracket (Y), the 3.5x14mm FLA (G) screw, the 8mm bushing (U) and the 5.0x50mm FLA (B).