

Quiditá

Essência da qualidade

Móveis Quiditá
Bento Gonçalves - RS
Rodovia BR-470 KM 202 - Cep 95710-000
Fone: 0xx (54) 3458-1001
www.quiditamoveis.com.br

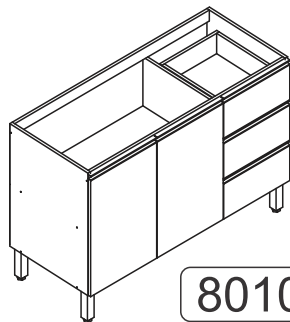

8010

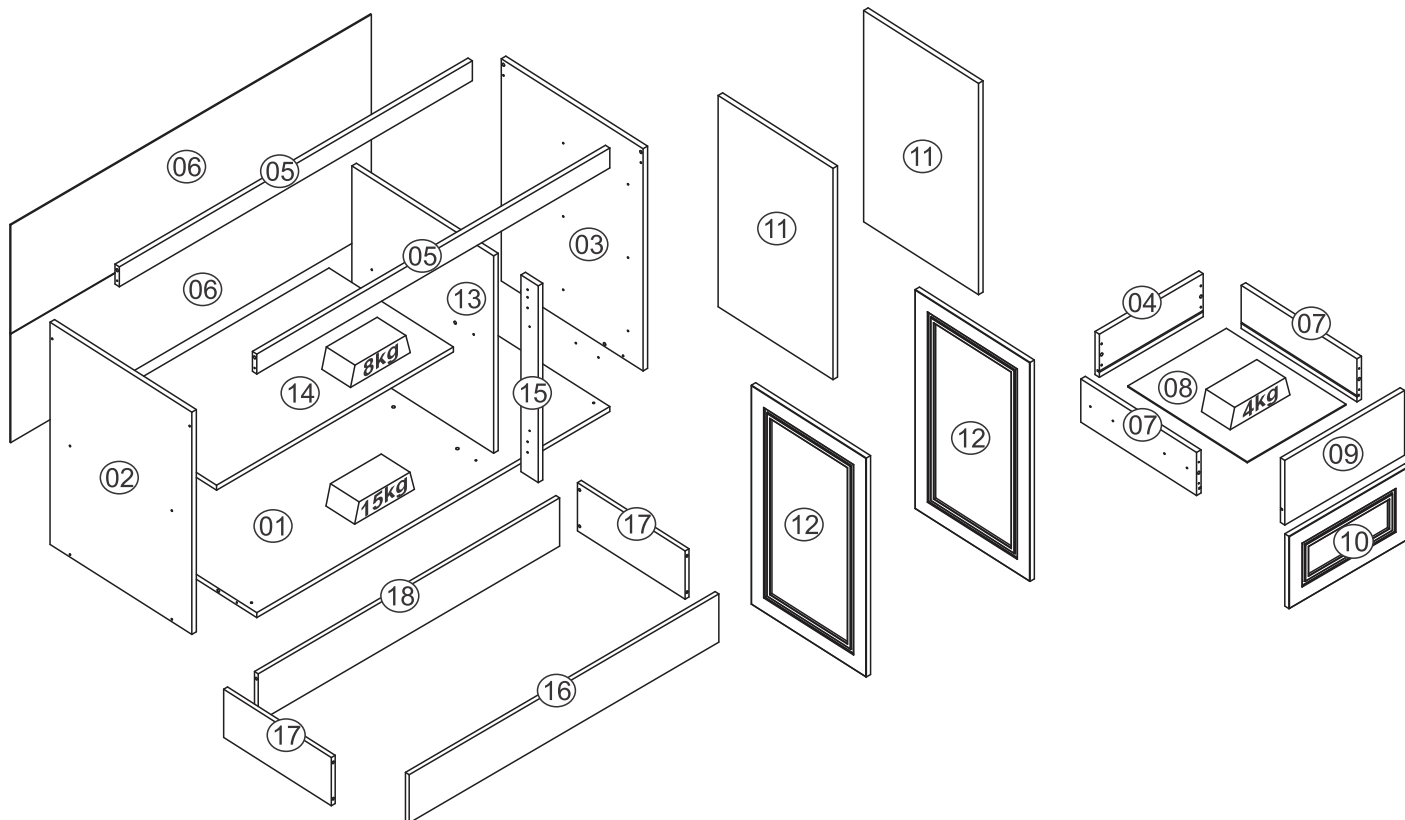

FERRAMENTAS NECESSÁRIAS
HERRAMIENTAS NECESARIAS
NECESSARY TOOLS/

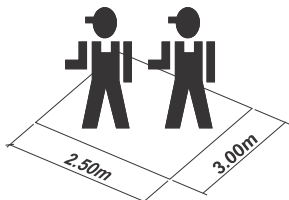
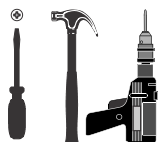

60 min













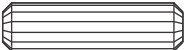

LISTA DE PEÇAS/RELACIÓN PIEZAS/PART LIST







Nº	Código Code	Descrição/Descripción/Description	Dimensão (mm) Dimensiones (mm) Measures (mm)	Qtde. Cantidad Quantity
01	801001	Base/Base/Base	1170 x 490 x 15	01
02	800003	Lateral esquerda/Left side/L teral izquierda	670 x 490 x 15	01
03	801002	Lateral direita/Right side/Lateral derecha	670 x 490 x 15	01
04	801008	Costa gaveta/Drawer back/Revés cajón	344 x 130x 15	03
05	801004	Travessa/Traverse/Travessaño	1770 x 60 x 15	02
06	801010	Costa/Revés/Back	1195 x 327 x 3	02
07	801007	Lateral gaveta/Drawer side/Lateral cajón	400 x 130 x 15	06
08	801011	Fundo gaveta/Drawer botom/Fondo cajón	413 x 327 x 3	03
09	801012	Frente gaveta/Drawer front/Frente cajón Ref. 8010	397 x 195 x 15	03
10	Q01307	Frente gaveta/Drawer front/Frente cajón Ref. 8210	218 x 397 x 15	03
11	800008	Porta/Door/Puerta Ref. 8010	637 x 397 x 15	02
12	Q01306	Porta/Door/Puerta Ref. 8210	660 x 397 x 15	02
13	801006	Divisão/Division/Divisória	595 x 490 x 15	01
14	801003	Prateleira/Shelf/Repisa	785 x 430 x 15	01
15	801005	Montante/Door traverse/Travessaño puerta	595 x 60 x 15	01

Ref. 8210



16	811501	Rodapé frontal/Front baseboard/Zócalo delantero	1200 x 170 x 15	01
17	810501	Rodapé lateral/Side baseboard/Zócalo lateral	435 x 170 x 15	02
18	811502	Rodapé traseiro/Back baseboard/Zócalo de atras	1168 x 170 x 15	01

FERRAGENS/HERRAJES/HARDWARE

A			Ø4,0x40mm	26
B		Cavilha/Tarugo/Dowel Ø8x30mm		26
C			Ø3,5x14mm	98
D			Ø4,0x25mm	04
E			Ø6,0x60mm	04
F			Ø5,0x50mm Ref. 8010	05
G		Prego/Clavo/Nail 10x10		33
H		Bucha/Cojinete/Bush 8mm		04
I				04
J				14
K		Garra metálica/Pieza fijación revés/ Back claw 13x13		07

L		Sache cola/Pegamento/Glue		01
M				05
N		Puxador perfil/Tirador/Handle 397mm Ref. 8010		05
O		Puxador/Tirador/Handle Ref. 8210		05
P		Trilho telescópico/Trillo telescópico/Telescopic sliding 350mm		03
Q		Tapa furo/Tapa agujero/Hole sticker 12mm		16
R		Dobradiça/Bisagra Hinge 35mm		04

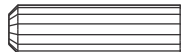
ROD1200

B		Cavilha/Tarugo/Dowel Ø8x30mm		08
C			Ø3,5x14mm	40
J				20

1 Separação corredeira/Separación corredera/Sliding separation

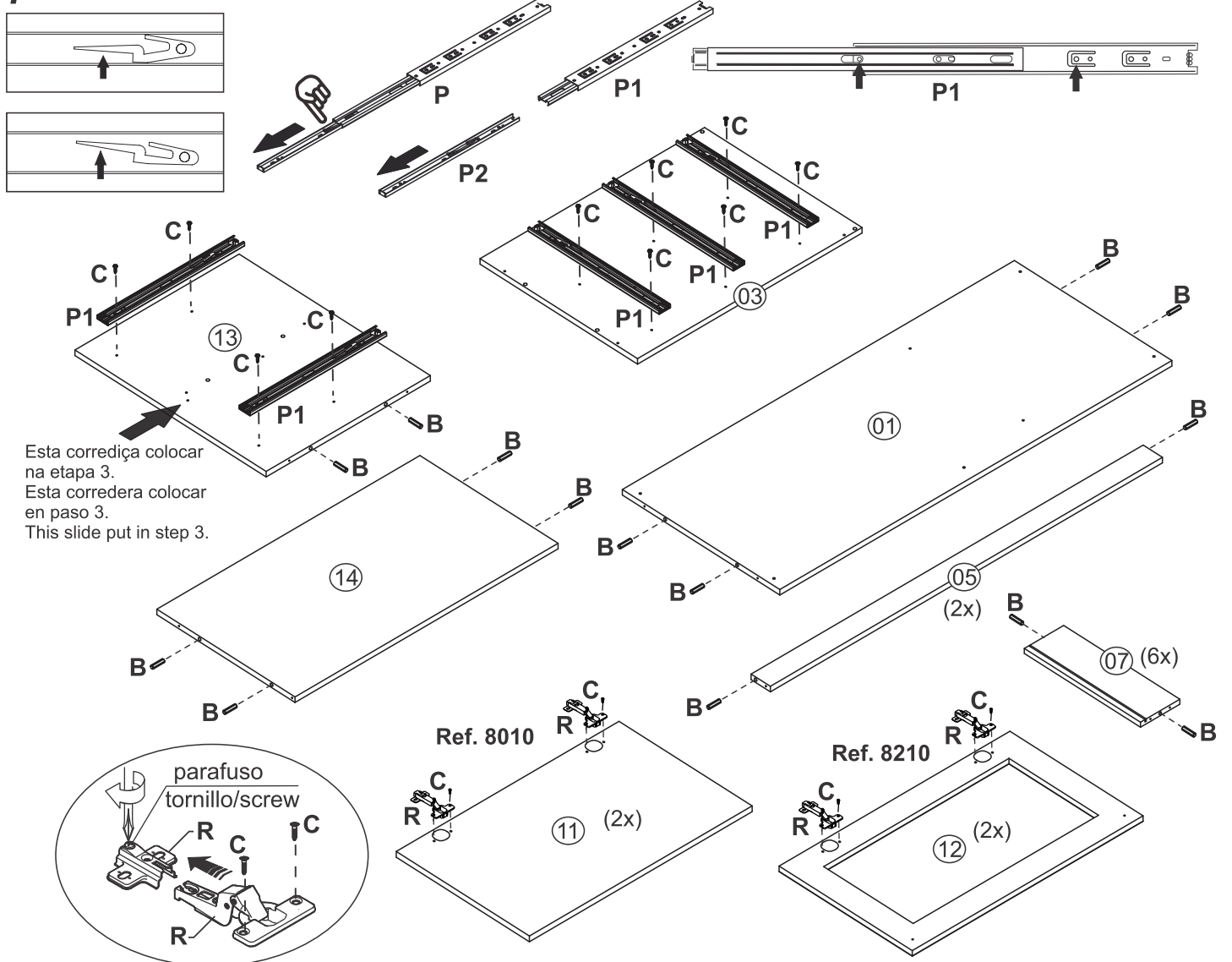

2

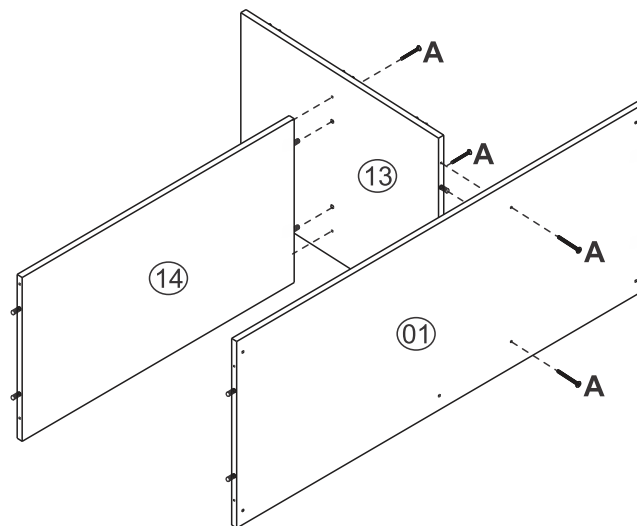

3

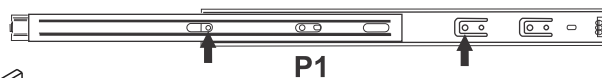
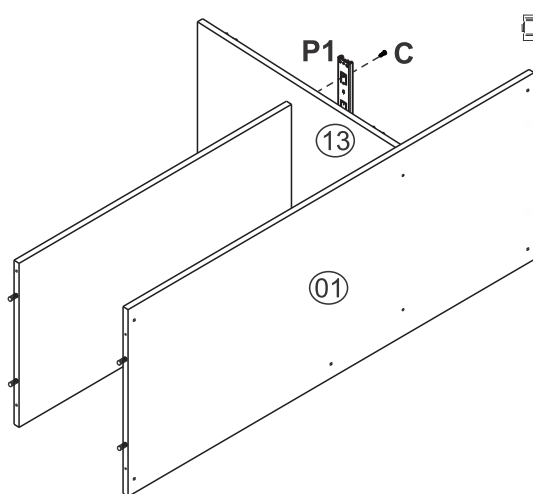

Fixar a corrediça central na divisão.
Fijar la corredera central en la divisoria.
Fix the central slide in the division.

4

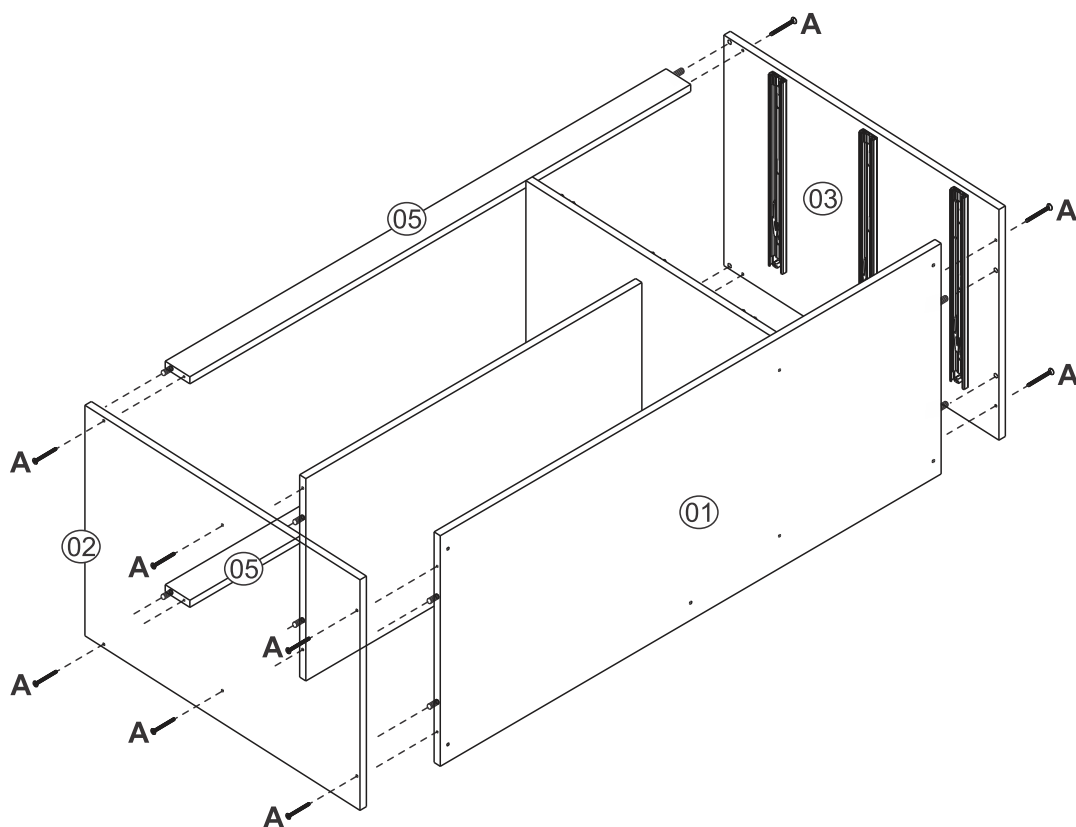

5 Ref. 8010

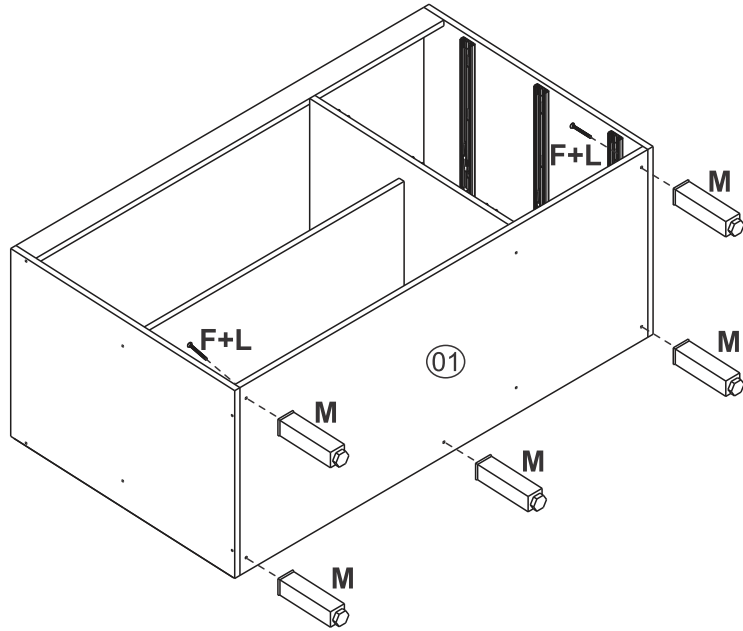

5 Ref. 8015

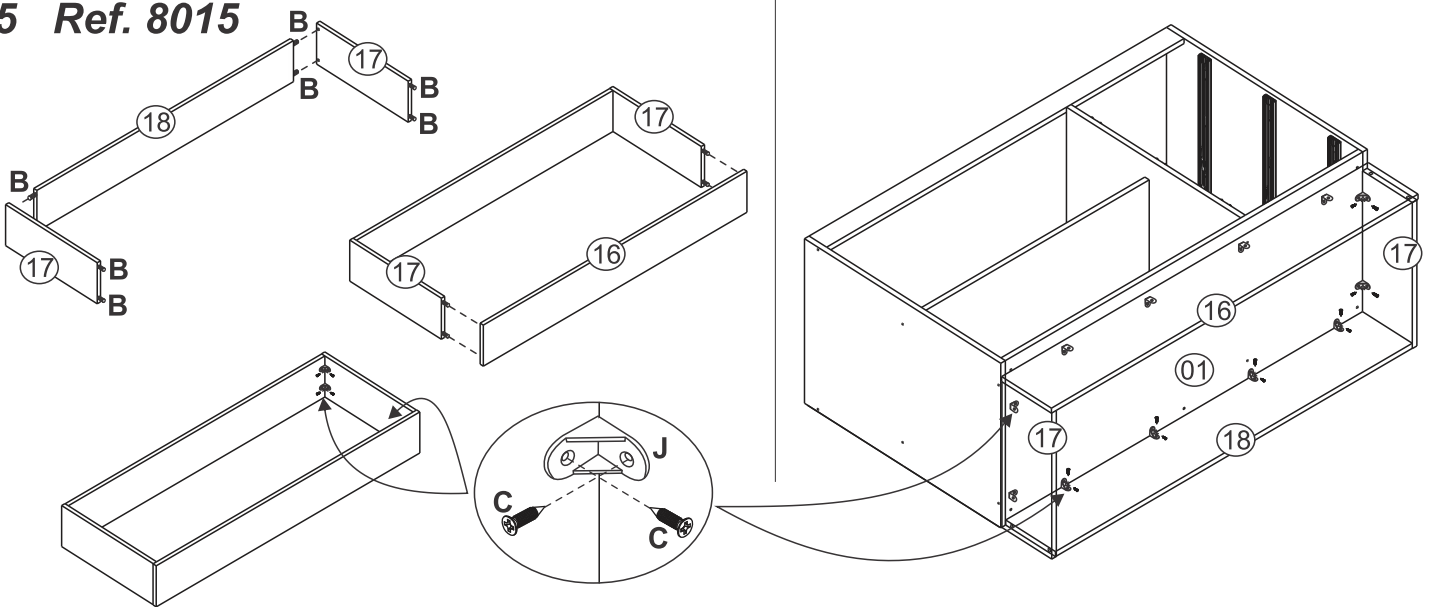

6 Ref. 8015/8215

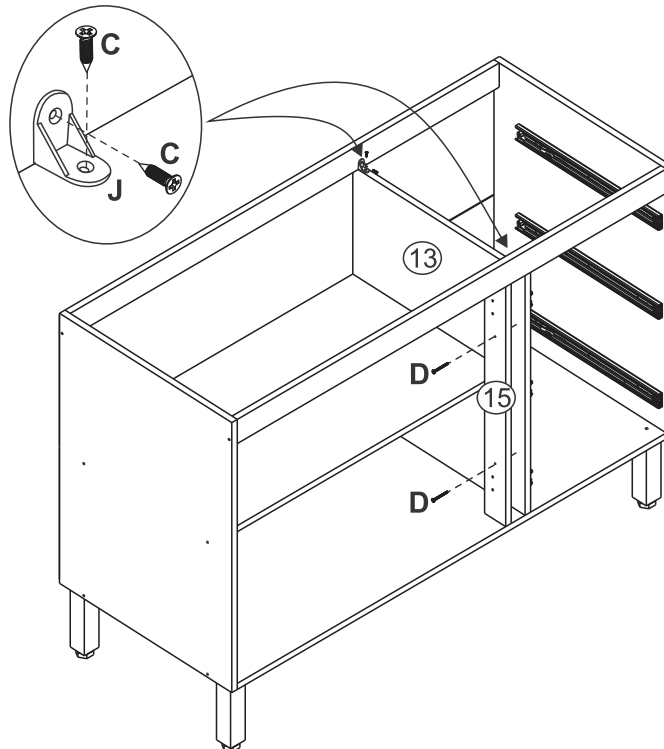

7

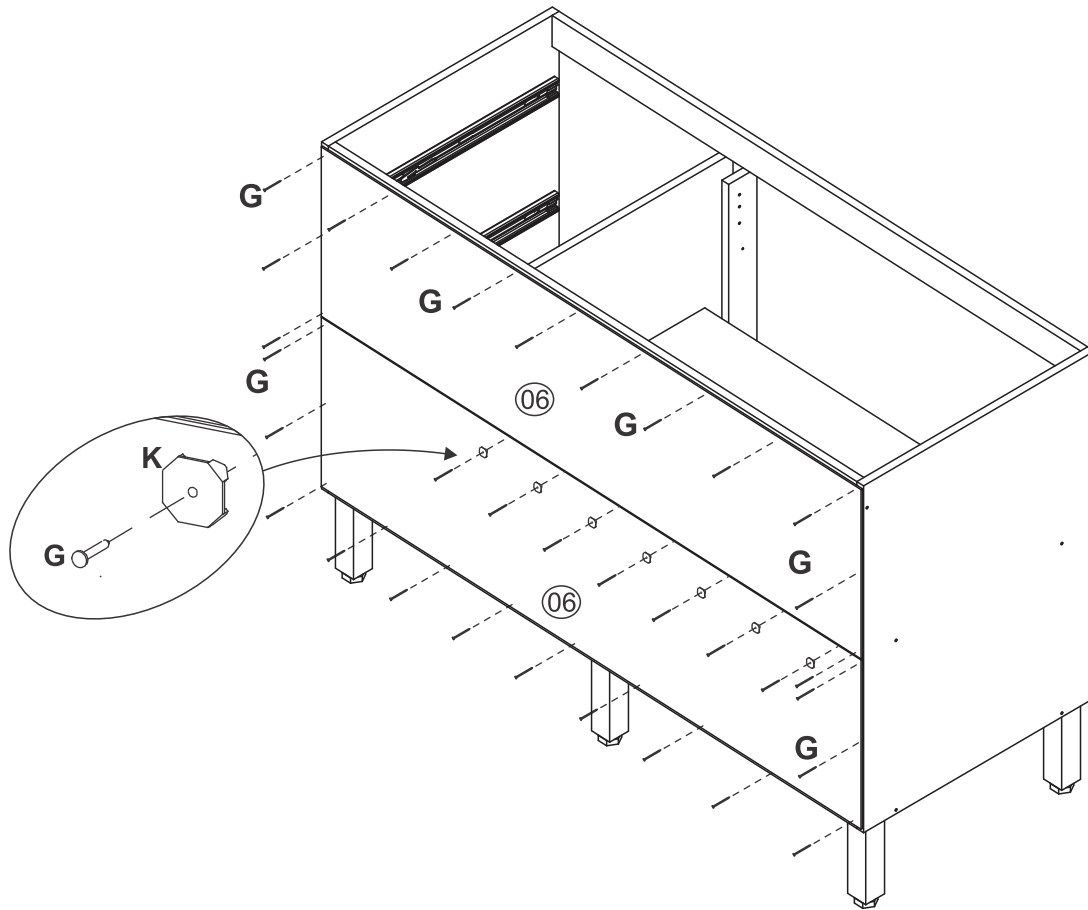

8 Fixação na parede - opcional
Fixing in the wall - optional
Fijación en pared - opcional

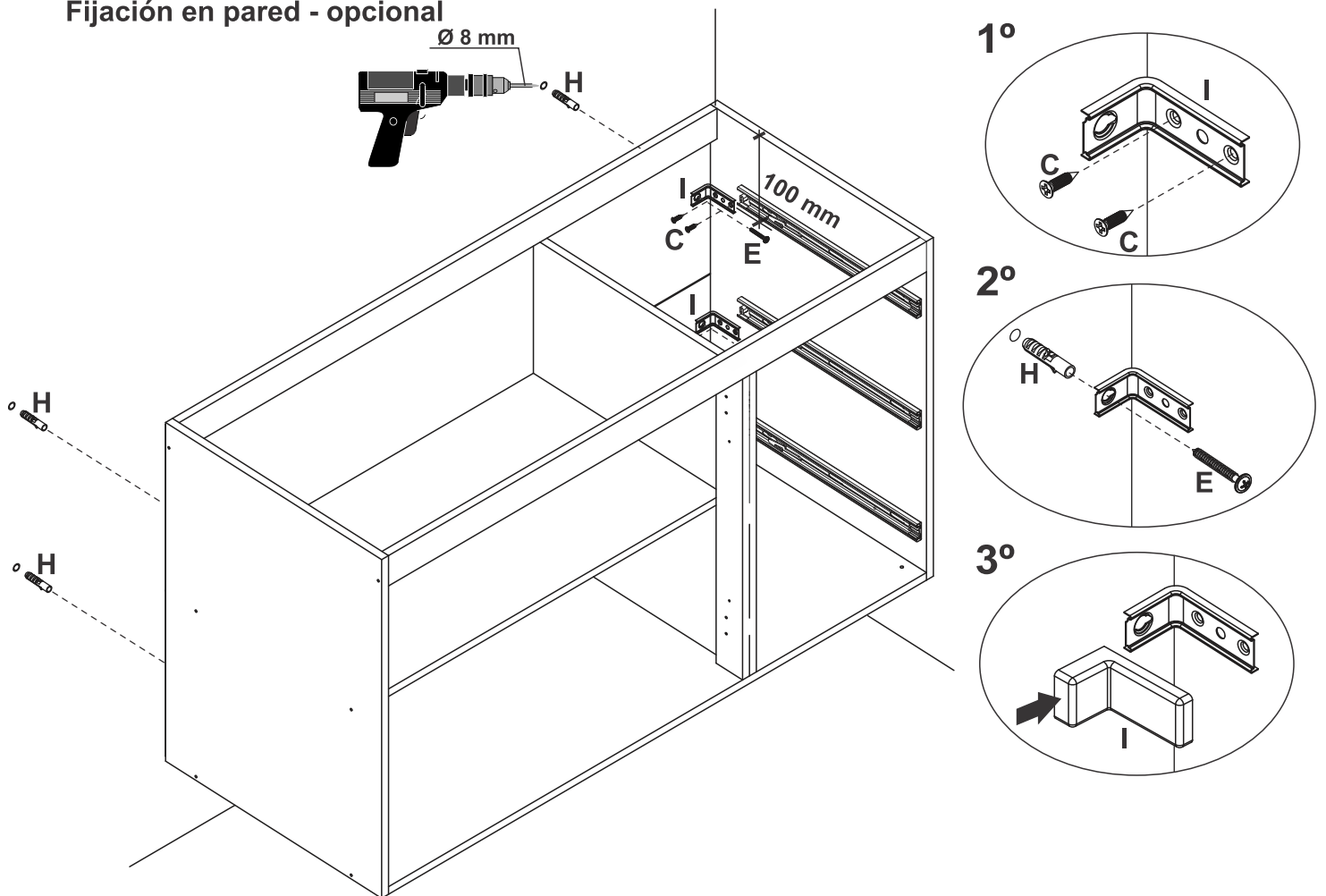

9

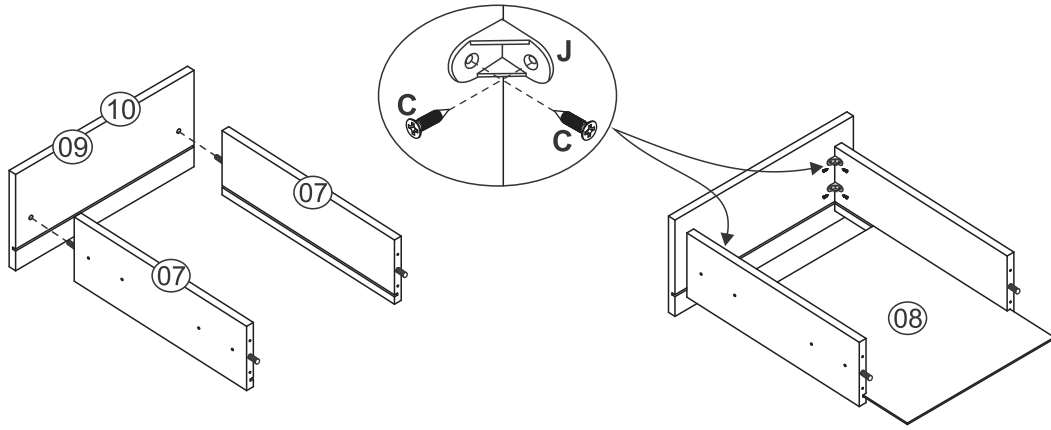

10

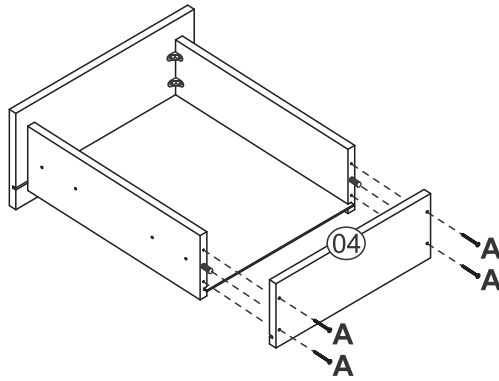

11

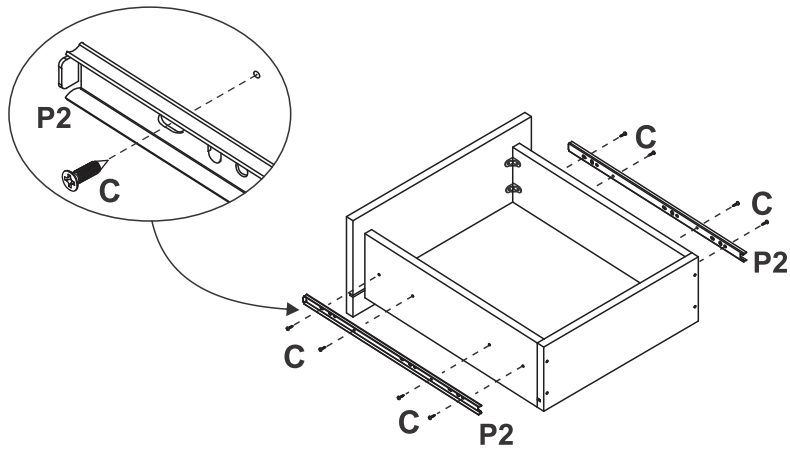

12

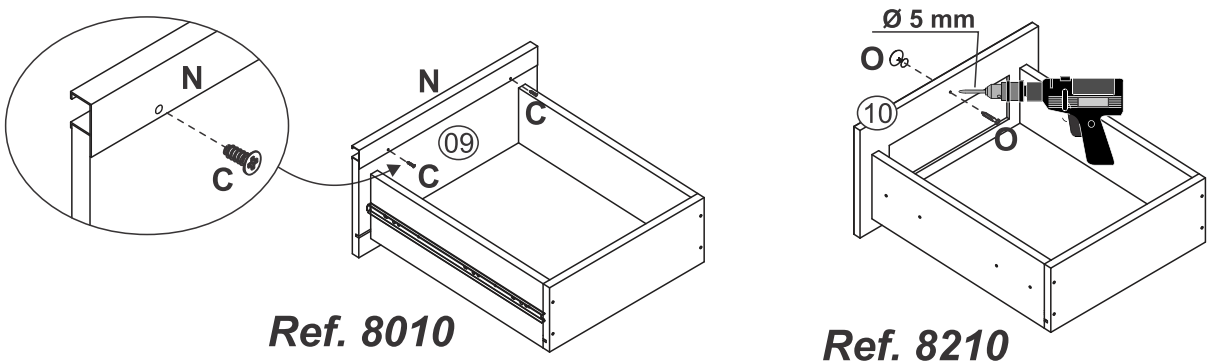

13 Posição de fixação do calço da dobradiça
Hinge base fixing position
Posición de fijación de la base de la bisagra

Ref. 8010

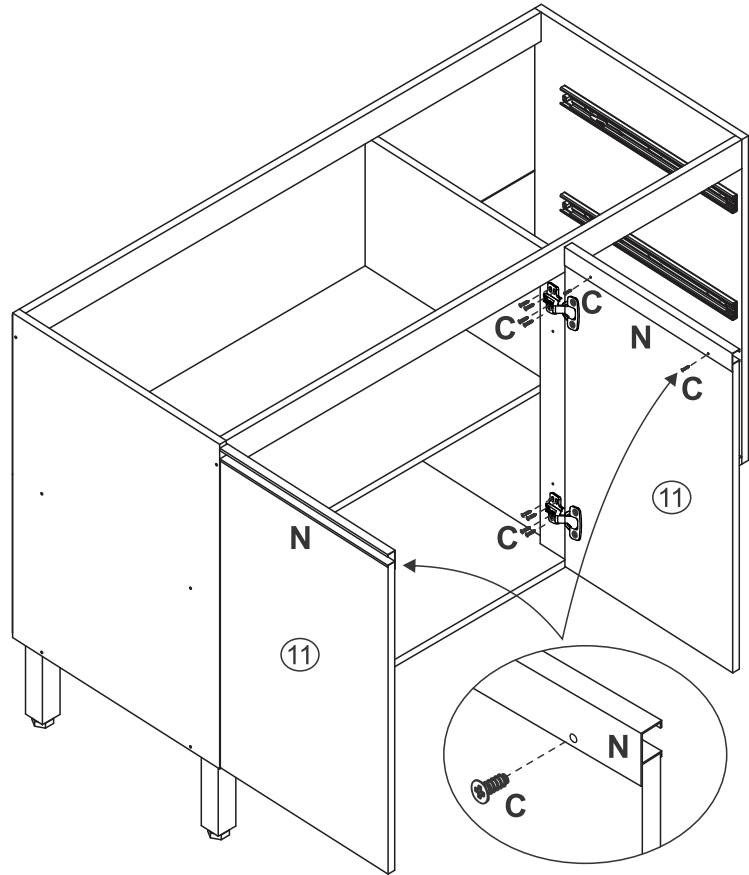
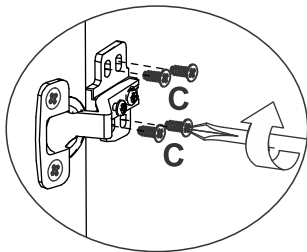
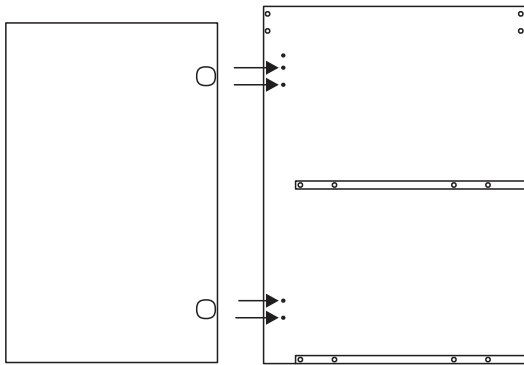

Ref. 8210

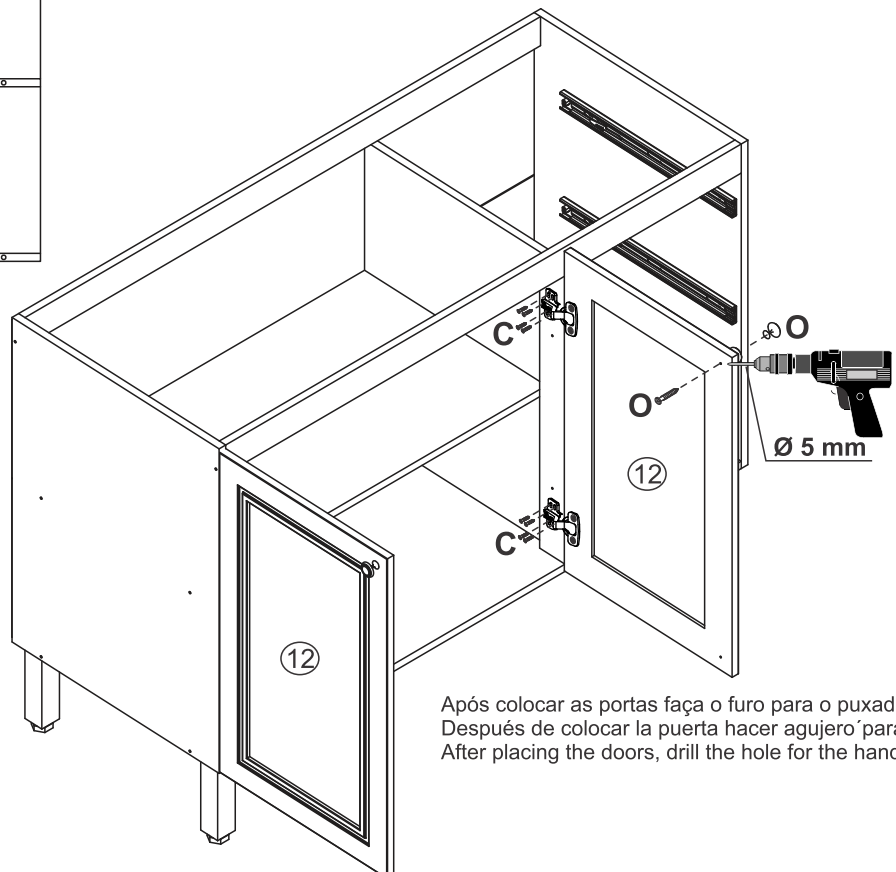
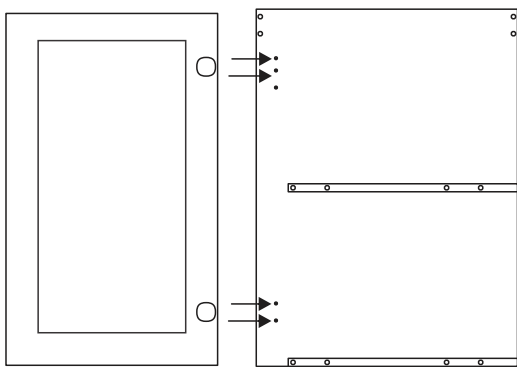

Após colocar as portas faça o furo para o puxador
Después de colocar la puerta hacer agujero para tornillo
After placing the doors, drill the hole for the handle



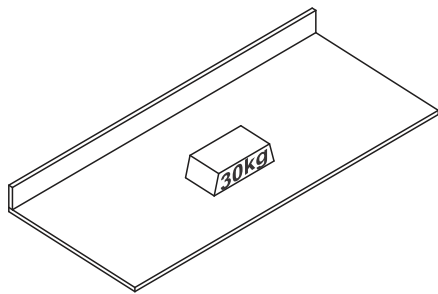

14

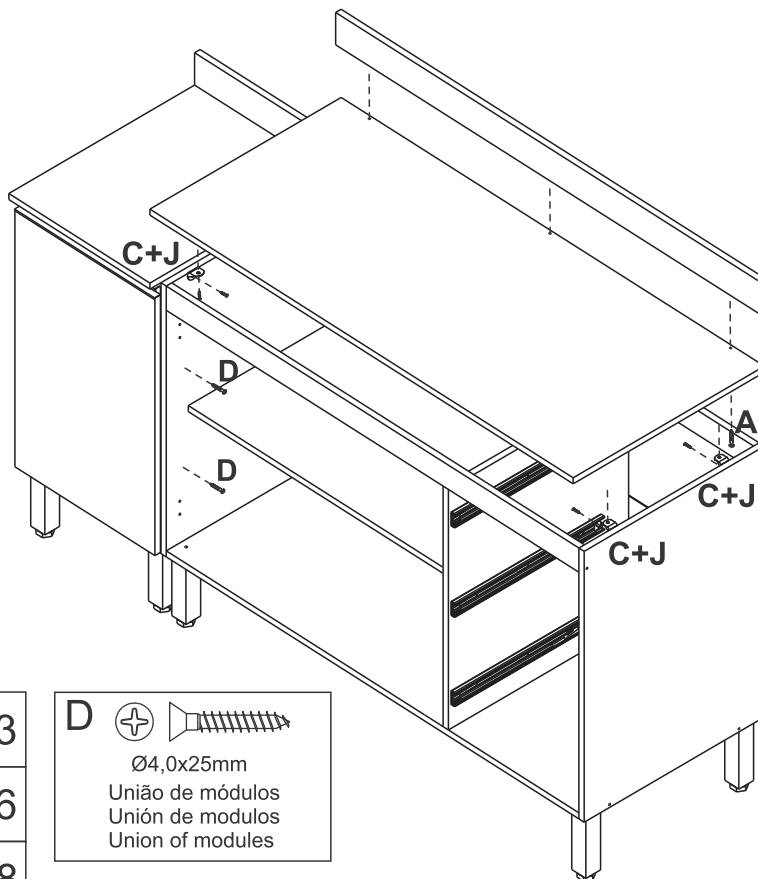



Tampo vendido separadamente
Top sold separately
La tapa se venden por separado



FERRAGENS/HERRAJES/HARDWARE

A	 	Ø4,0x40mm	03
C	 	Ø3,5x14mm	16
J			08

D	 	Ø4,0x25mm União de módulos Unión de módulos Union of modules
---	---	---

15

