

Balcão Pia 02 Gavetas 03 Portas Connect

Pia Contador 02 Cajones 03 Puertas Connect | Balcony Pia 02 Drawers 03 Doors Connect
C66-35 Duna/Cristal | C66-42 Fendi

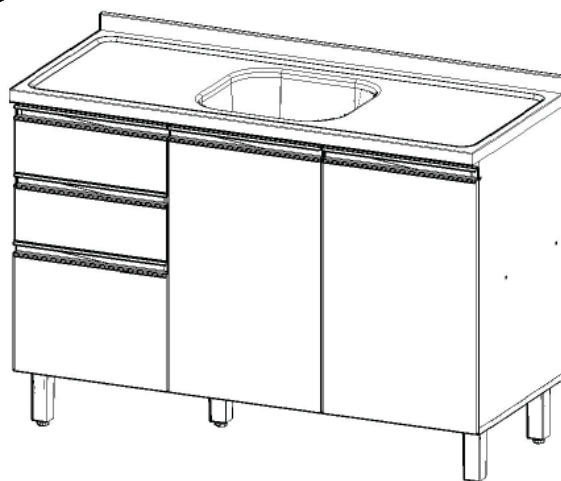
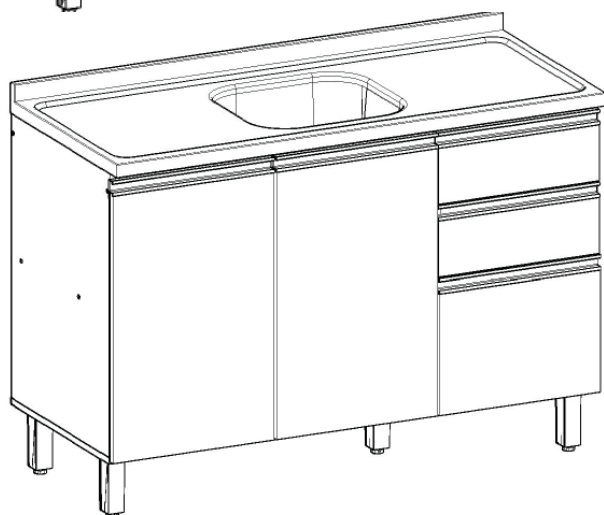
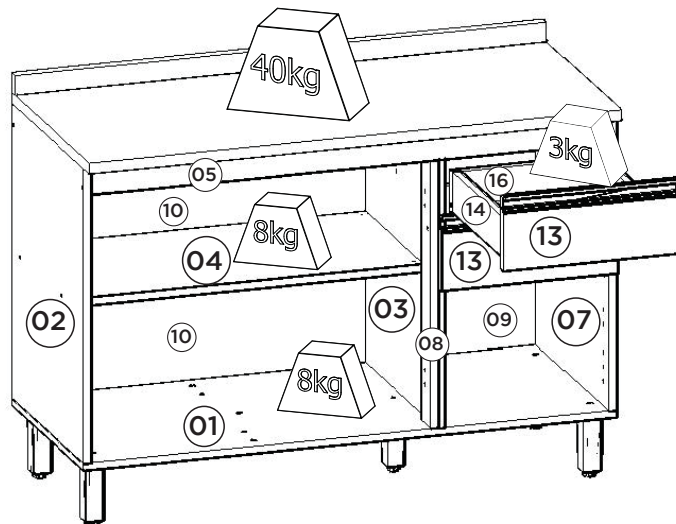
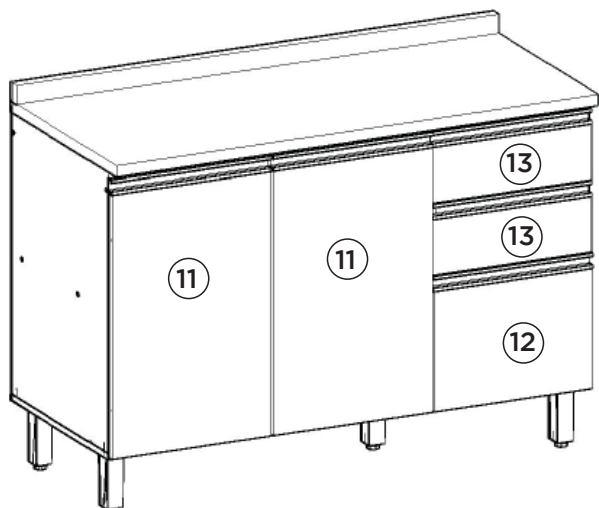

Pesos máximos recomendados com carga distribuída
Peso máximo recomendado con la carga distribuida
Recommended maximum weights with evenly distributed.

Requisitos para montagem Requisitor para la montaje Assembly Requirements

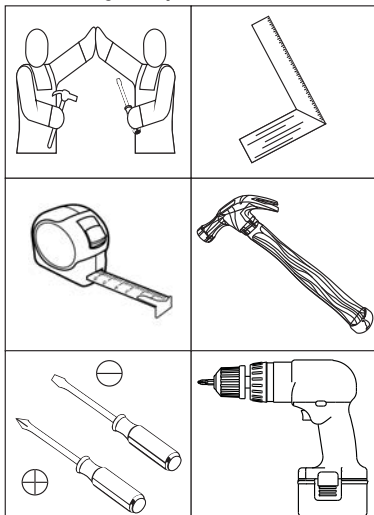

Imagens meramente ilustrativas
Imágenes meramente ilustrativas
Images for illustration only

AVISO

Para limpeza de seu móvel, use uma flanela seca ou umedecida, e não utilize produtos químicos que possam danificar seu produto.

SISTEMA DE MONTAGEM

O sistema de montagem dos produtos, funciona de acordo com a ordem crescente dos números indicados no desenho. Ex: 01, 02, 03, 04... até a conclusão da montagem.

ADVERTENCIA

Para limpieza de su móvil, use una flanela seca o húmeda, y no utilice productos químicos que puedan dañar su producto.

SISTEMA DE MONTAJE

El sistema de montaje de los productos funciona de acuerdo con el orden creciente de los números indicados en el dibujo. Ej.: 01, 02, 03, 04... hasta la conclusión del montaje.

NOTICE

To clean your furniture, use a dry or wet cloth, and do not use chemicals that may damage your product.

ASSEMBLY SYSTEM

The products' assembly system works according to the increasing order of the indicated numbers. For example: 01, 02, 03, 04 ... to the end of the assembly.

1º

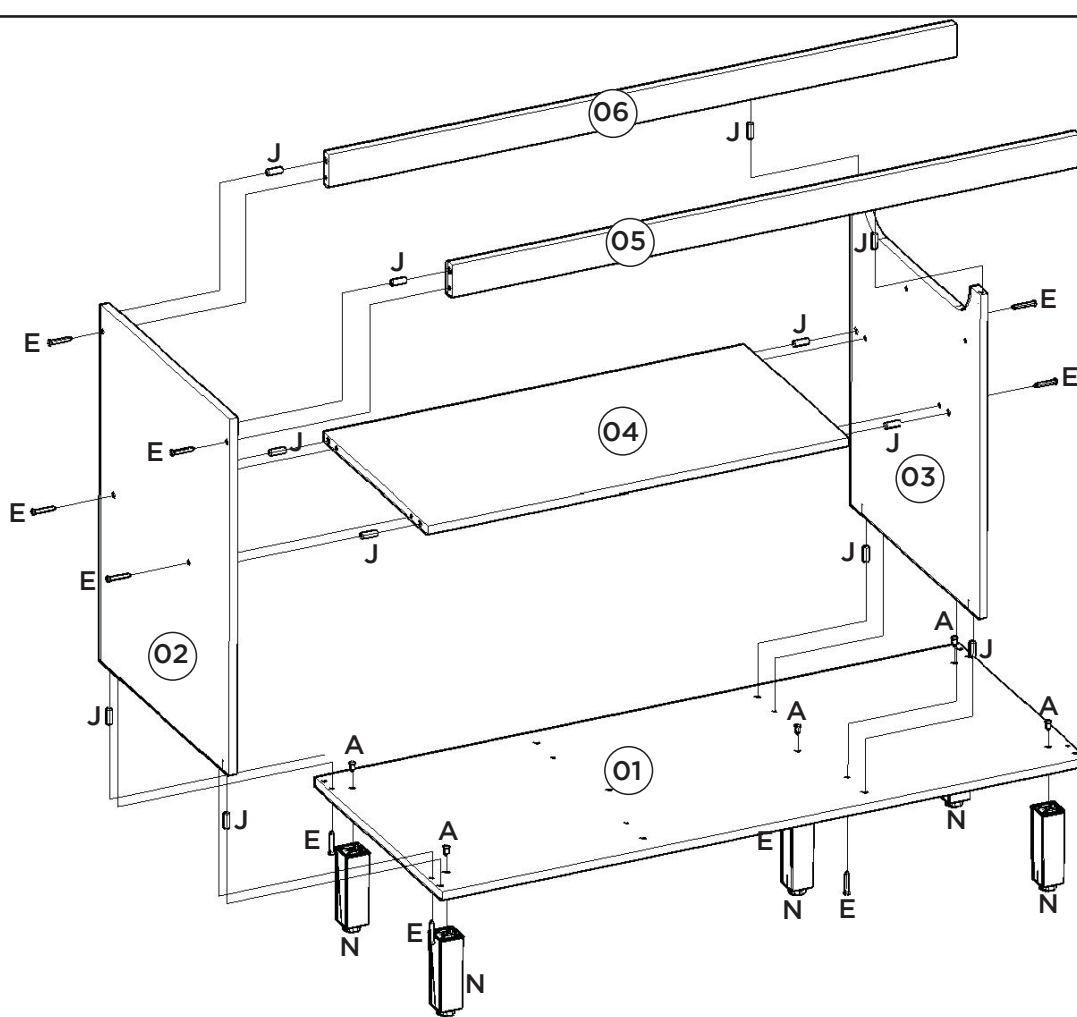

2º

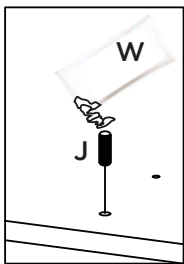

Utilizar o sachê de cola (W) em todas as cavilhas (J) do produto.

Con el pegamento sobre (W) en todos los pernos (J) producto.

Use the glue sachet (W) on all the pegs (J) of the product.

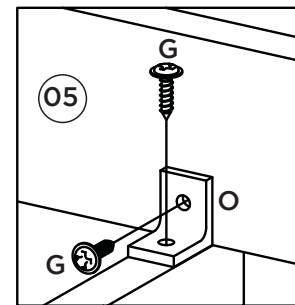

A pilastra da porta (08) deve estar alinhada com a divisão (03).

El pilar de la puerta (08) debe estar alineado con la división (03).

The door pillar (08) must be aligned with the partition (03).

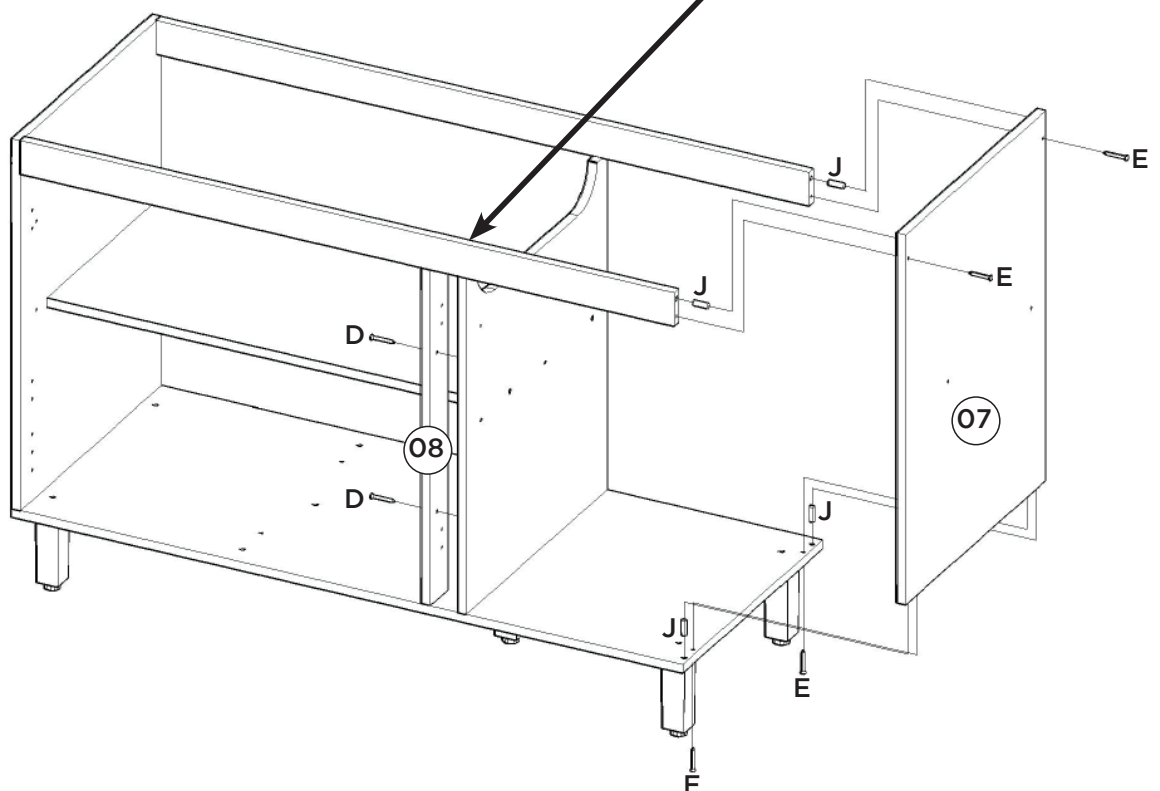

3º

Esse tampo é opcional e é vendido separadamente (C905-33).

Esta vez es opcional y se vende por separado (C905-33).

This top is optional and is sold separately (C905-33).

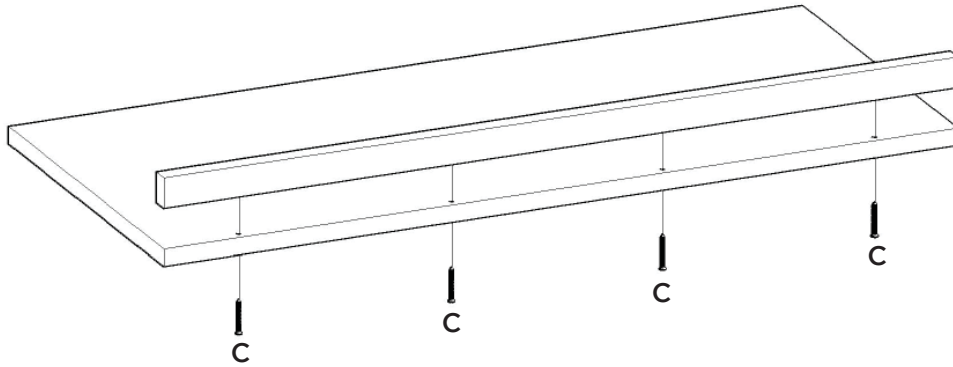

4º

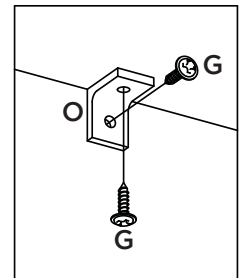
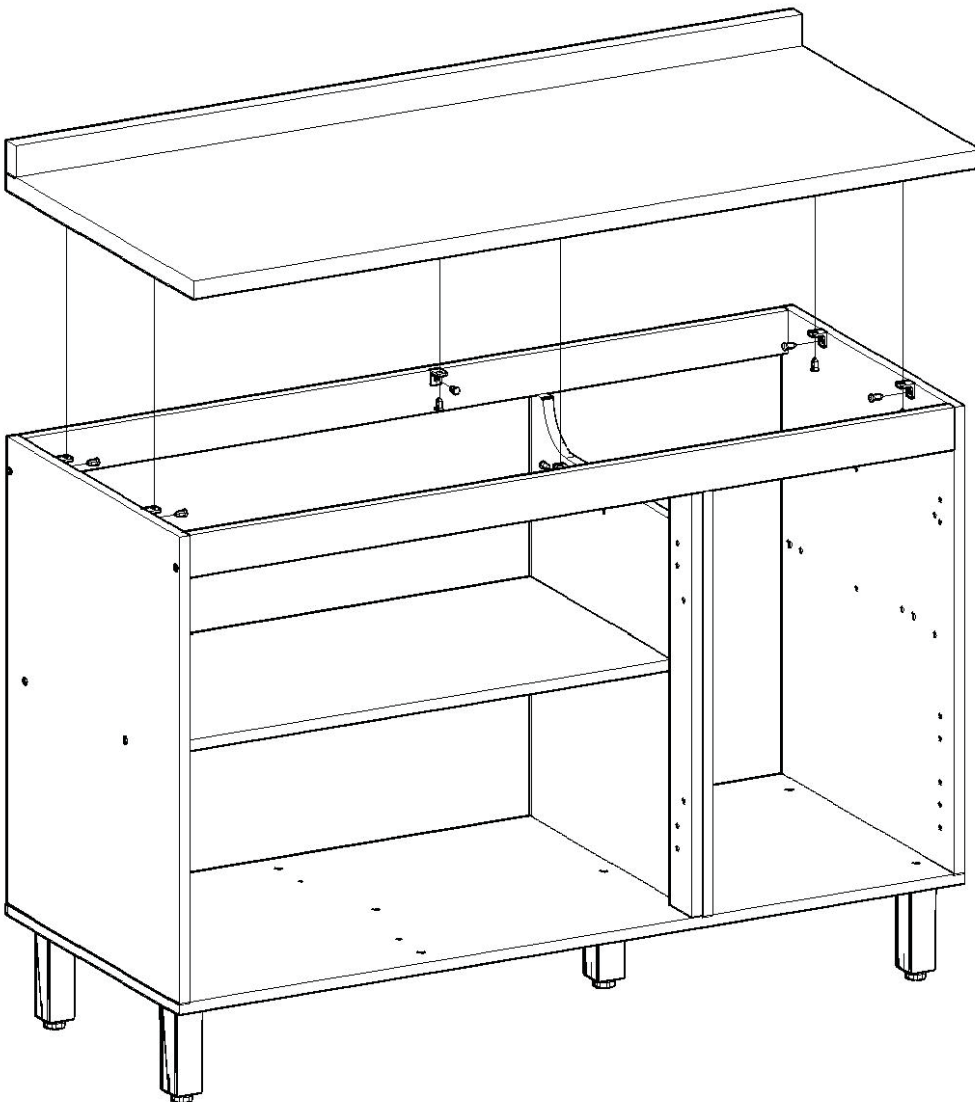

Caso o móvel seja montado com a opção do tampo, fixar o mesmo com 06 cantoneiras (O) e os parafusos 3,5x14mm (G).

Si se monta el auricular con la opción de la cubierta, fijarlo con Los ángulos 06 (O) y 3,5 x14mm tornillos (G).

If the furniture is to be installed with the top cover option, fix it with 06 (O) and 3.5x14mm screws (G).

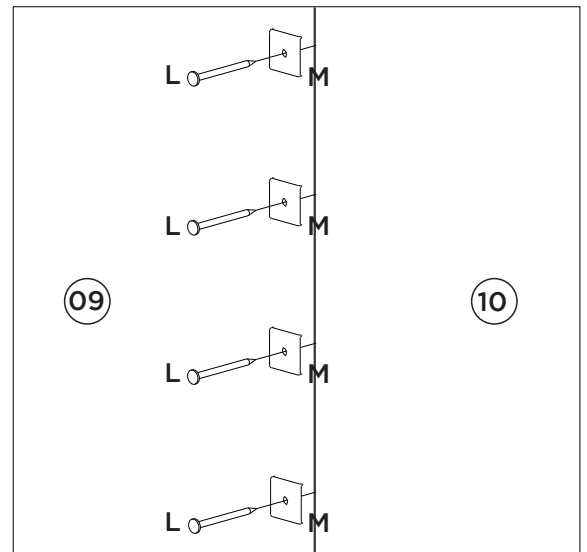
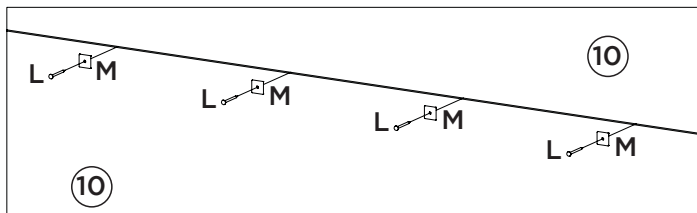
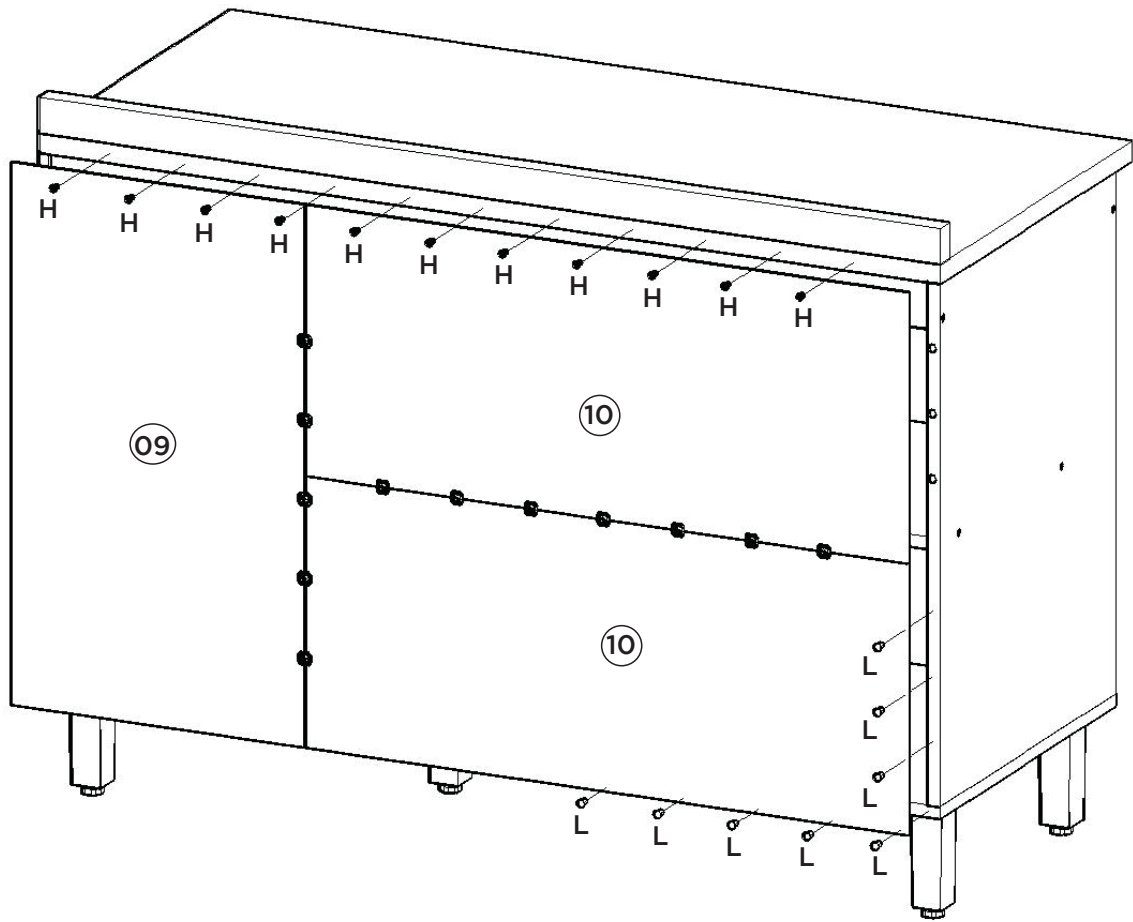

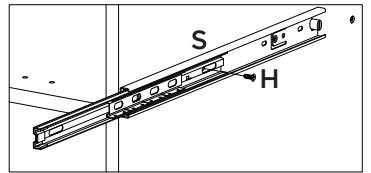
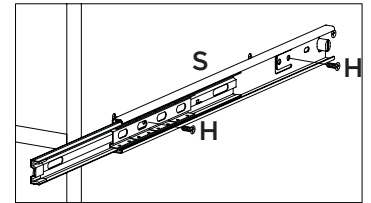
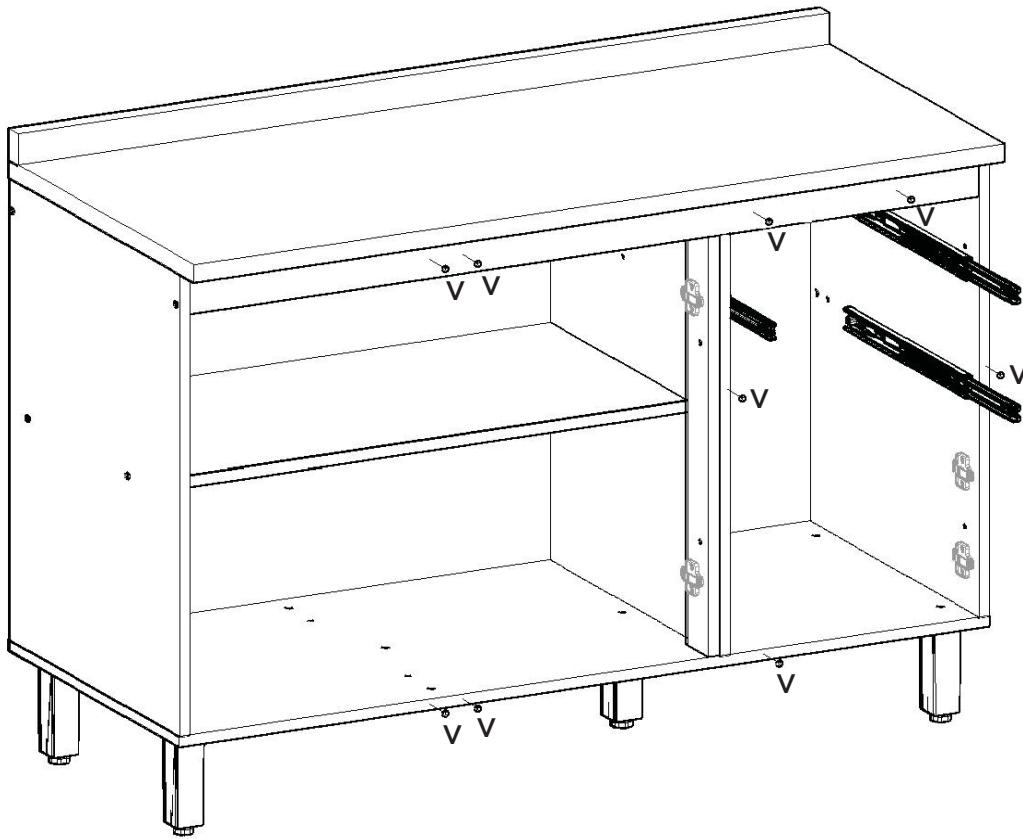

Fixação da corrediça telescópica (S).

Fijación Slide telescópico (S).

Fixing of the telescopic slide (S).

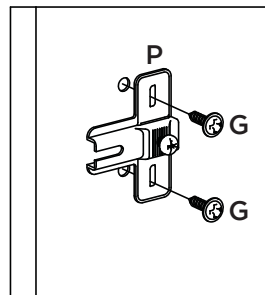

Fixação do calço 5mm (P).

Montaje de la placa de 5mm (P).

Shim fixation 5mm (P).

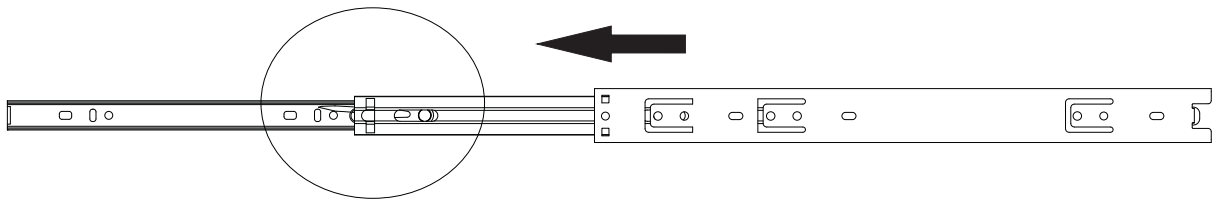

Para a desmontagem da corrediça siga a instrução ao lado.

Para el desmontaje seguimiento de diapositivas la instrucción siguiente a.

For the dismount of the sliding onem follows the instruction aside.

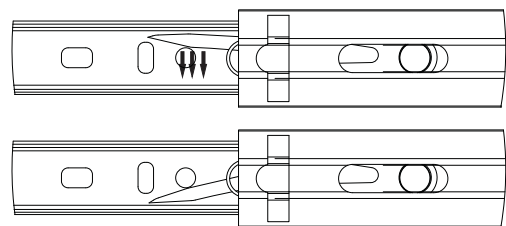

Fixar as corrediças nessas furações
Fijar las diapositivas de estos agujeros
Fix slides in these drillings

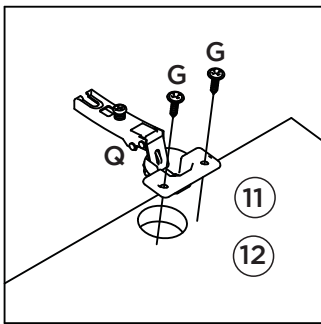

Fixação da dobradiça (Q).

La fijación de la bisagra (Q).

Hinge fixing (Q).

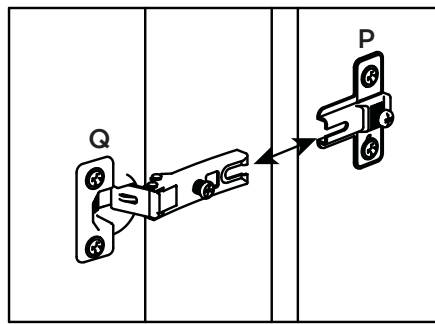

Encaixe da dobradiça (Q) com o calço (P).

Fije la bisagra (Q) con cuña (P).

Hinge fitting (Q) with shim (P).

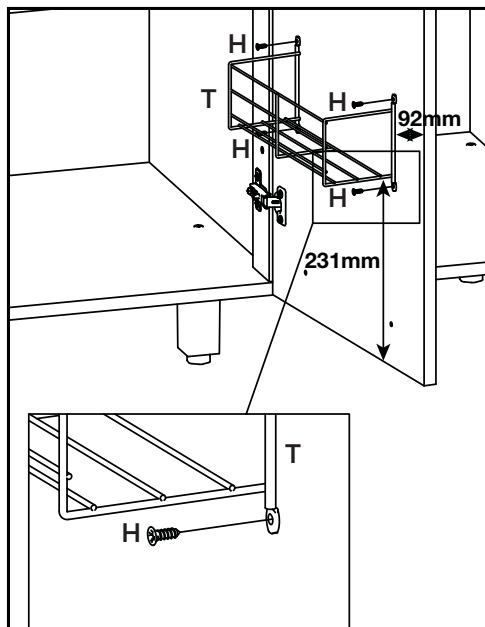
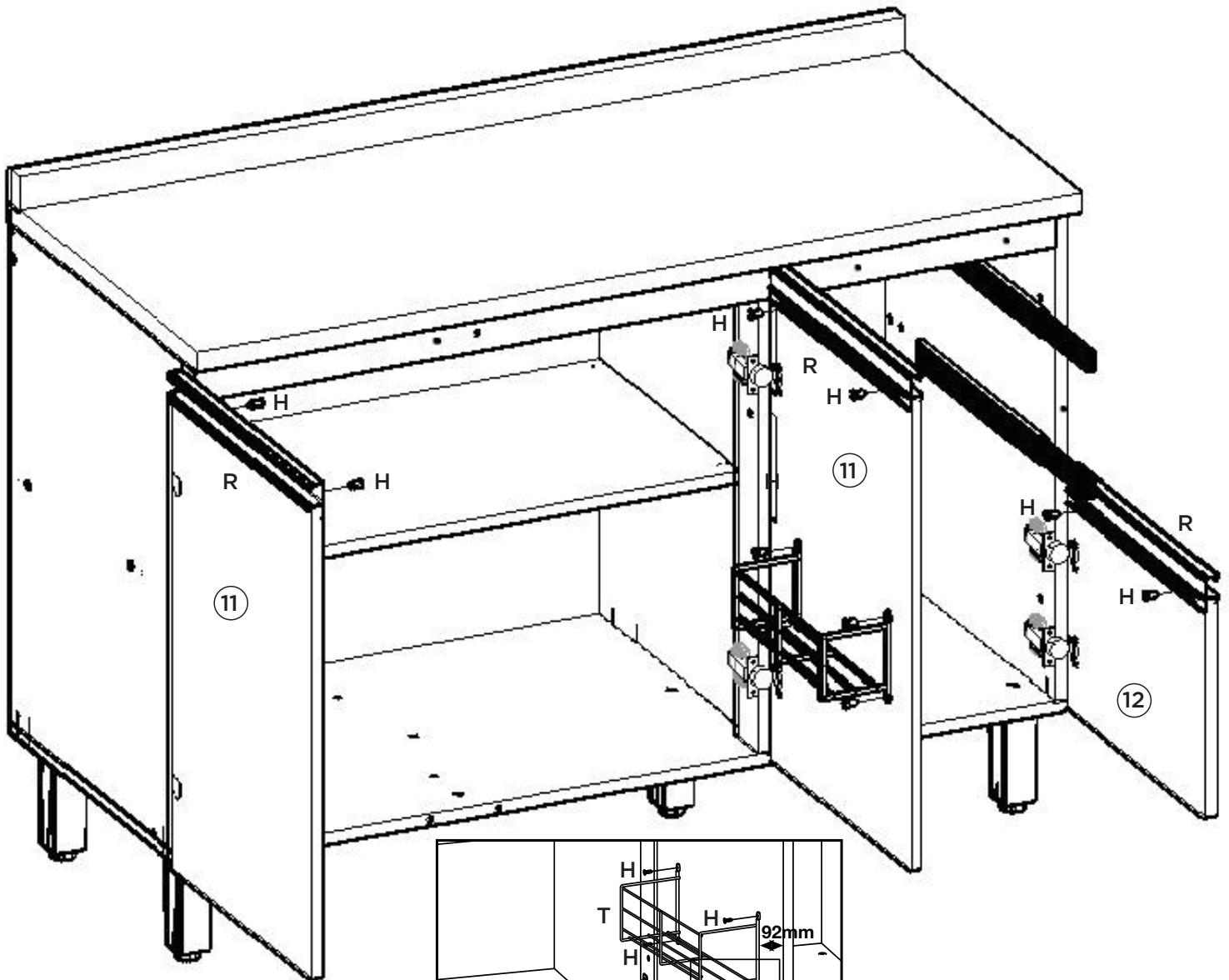

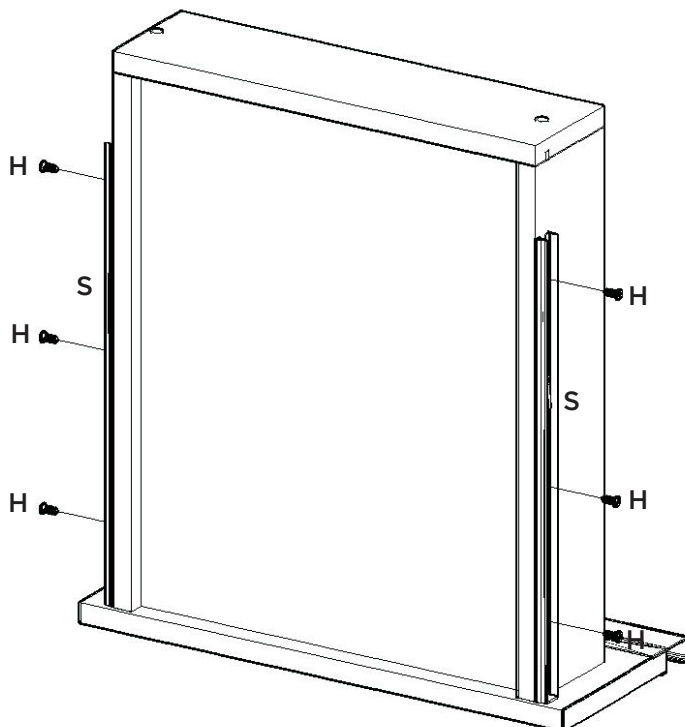
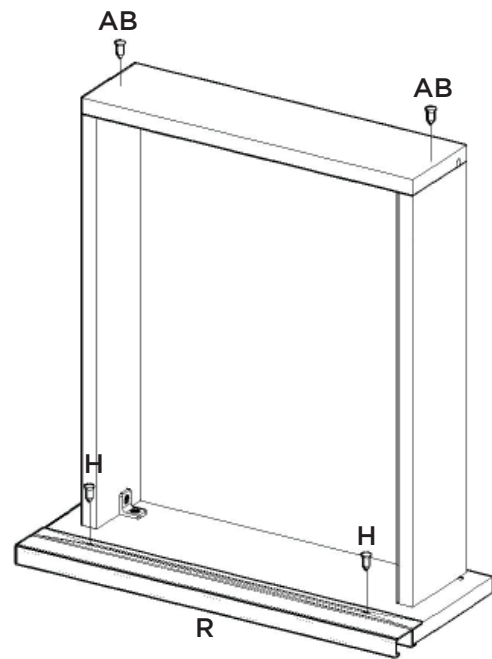
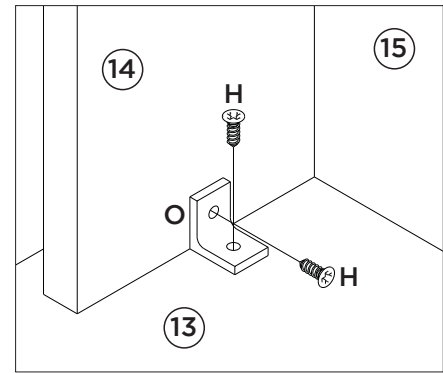
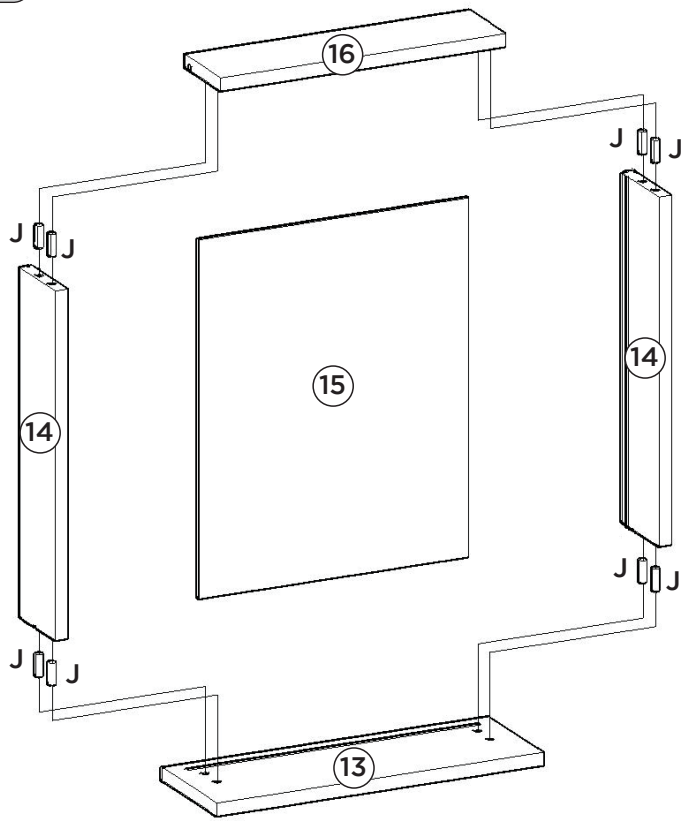











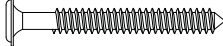

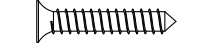

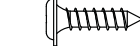





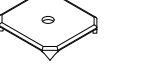

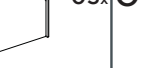
A corrediça (S) deverá ser alinhada com a parte de baixo do lado de gaveta (14).

La carcasa (S) será alineada con la parte de por el lado del cajón (14).

The slide (S) should be aligned with the underside of the drawer side (14).

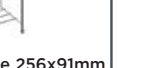
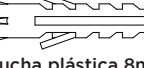
| Item | Caixa Caja Box | Qty Ctd Qty | Descrição Descripción Description | Medidas (mm) Dimensions (mm) Size (measurements) (mm) |
|------|----------------------|-------------------|--|---|
| 01 | 1/1 | 01 | Base Base Base | 1200x490x15 |
| 02 | 1/1 | 01 | Lateral esquerda Lateral izquierda Left side | 660x490x15 |
| 03 | 1/1 | 01 | Divisão División Division | 600x490x15 |
| 04 | 1/1 | 01 | Prateleira Estante Shelf | 783x400x15 |
| 05 | 1/1 | 01 | Travessa frontal Travesaño frontal Front crossbar | 1168x60x15 |
| 06 | 1/1 | 01 | Travessa traseira Travesaño trasero Rear bumper | 1168x60x15 |
| 07 | 1/1 | 01 | Lateral direita Lateral derecha Right side | 660x490x15 |
| 08 | 1/1 | 01 | Pilastra da Porta Pilastra Puerta Pilaster door | 599x60x15 |
| 09 | 1/1 | 01 | Fundo menor Fondo menor Minor fund | 683x389x3 |
| 10 | 1/1 | 02 | Fundo Fondo Bottom | 802x341x3 |
| 11 | 1/1 | 02 | Porta Puerta Door | 625x396x15 |
| 12 | 1/1 | 01 | Porta menor Puerta menor Smaller door | 396x290x15 |
| 13 | 1/1 | 02 | Frente de gaveta Frente de cajón Front of drawer | 396x136x15 |
| 14 | 1/1 | 04 | Lado de Gaveta menor Lado del cajón menor Smallest Drawer Side | 400x90x15 |
| 15 | 1/1 | 02 | Fundo de gaveta Fondo de cajón Bottom of drawer | 411x326x3 |
| 16 | 1/1 | 02 | Ripa de trás Malla detrás Rear lath | 345x90x15 |

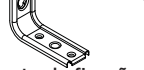
Ferragens | Herrajes | Hardware

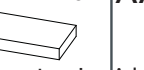
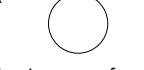
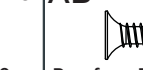
| | | | | | |
|--|---|---|---|---|---|
| A  Parafuso 7,0x40mm CHT. Tornillo 7,0x40mm CHT. Screw 7,0x40mm CHT. | B  Parafuso 5,0x50mm FLA. Tornillo 5,0x50mm FLA. Screw 5,0x50mm FLA. | C  Parafuso 4,5x50mm CHT. Tornillo 4,5x50mm CHT. Screw 4,5x50mm CHT. | D  Parafuso 4,0x25mm CHT. Tornillo 4,0x25mm CHT. Screw 4,0x25mm CHT. | E  Parafuso 3,5x40mm CHT. Tornillo 3,5x40mm CHT. Screw 3,5x40mm CHT. | F  Divisor talheres 398x313mm Divisor cubiertos 398x313mm Cutlery divider 398x313mm |
| G  Parafuso 3,5x14mm FLA. Tornillo 3,5x14mm FLA. Screw 3,5x14mm FLA. | H  Parafuso 3,5x12mm CHT. Tornillo 3,5x12mm CHT. Screw 3,5x12mm CHT. | I  Giz de correção Tiza de corrección Chalk of correction | J  Cavilha 8x25mm Cinta 8x25mm Dowel 8x25mm | K  Etiqueta resinada Henn Etiqueta resinada Henn Henn resin label | L  Prego 10x10mm Clavo 10x10mm Nail 10x10mm |
| M  Fixador de fundos Fijador de fondos Bottom fixer | N  Pé 145mm x 42mm Pie 145mm x 42mm Foot 145mm x 42mm | O  Cantoneira plástica Cantonera plástica Plastic angle brackets | P  Calço metal médio 0mm Calzado metálico medio 0mm Metal shim 0mm | Q  Dobradiça metal Baixa 35mm Bisagra metálica Baja 35mm Metal hinge Low 35mm | R  Puxador MOV 396mm Tirador MOV 396mm MOV 396mm Handle |
| S  Corrediza telescópica Diapositivas telescópicas Telescopic slides | T  Porta detergente 256x91mm Puerta detergente 256x91mm Detergent door 256x91mm | U  Bucha plástica 8mm Bucha de plástico 8mm 8mm plastic bushing | V  Batente PVC para Porta Parada de PVC para Puerta PVC Door Stop | W  Sachê de cola Bolsa de pegamento Glue bag | X  Adesivo tapa parafuso 17mm Adhesivo tapón de tornillo 17mm Bolt cover adhesive 17mm |
| Y  Suporte de fixação Soporte de fijación Mounting bracket | Z  Proteção para cantoneira Ángulo de protección Protection angle | AA  Adesivo tapa parafuso 10mm Adhesivo tapón de tornillo 10mm Bolt cover adhesive 10mm | AB  Parafuso 3,0x30mm CHT. Tornillo 3,0x30mm CHT. Screw 3,0x30mm CHT. | AC  Parafuso União 30mm Tornillo Unión 30mm Union Screw 30mm | |



O parafuso (AC) deve ser usada somente quando este módulo for acoplado a outro módulo componível Henn.

RECOMENDAÇÃO

Para fixar o móvel na parede usar o suporte de fixação (Y), o parafuso 3,5x14mm FLA (G), a Bucha 8mm (U) e o parafuso 5,0x50mm FLA (B).



El tornillo (AC) se debe utilizar sólo cuando el módulo está conectado a otro módulo componible Henn.

RECOMENDACIÓN

Para conectar el móvil a la pared con el soporte (Y), tornillo 3,5 x14mm FLA (G), el casquillo de 8 mm (U) y el 5,0 x50mm tornillo FLA (B).



The screw (AC) should be used only when this module is attached to another Henn modular module.

RECOMMENDATION

To fix the furniture to the wall use the mounting bracket (Y), the 3.5x14mm FLA (G) screw, the 8mm bushing (U) and the 5.0x50mm FLA (B).