

Manual de montagem / Plano de armado

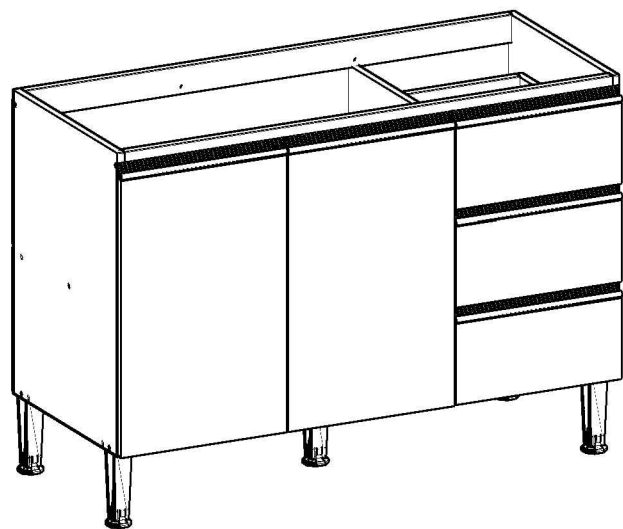

Ref.: 1314M

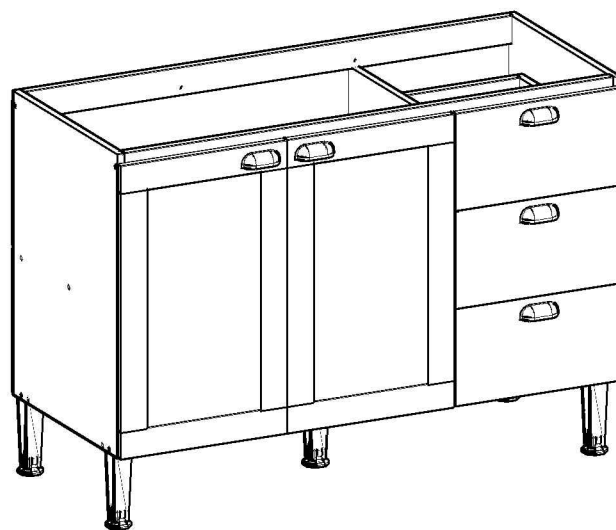

Ref.: 1314P

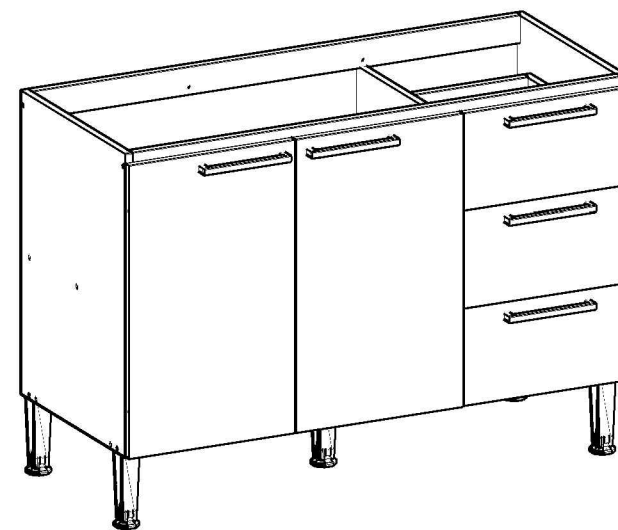

Ref.: 1314L

Parabéns! Você comprou um produto de excelente qualidade, fabricado com chapa de madeira de MDP ou MDF, extraída de florestas renováveis. Possui alta resistência e design atual.

Felicitaciones! Usted compró a un producto de excelente calidad, fabricado con placa de madera de MDP o MDF, proveniente de florestas renovables. Tiene alta resistencia y diseño actual.

Antes de montar o móvel, leia com atenção o manual de montagem!

Antes de armar el mueble, lea con atención el manual de ensamble!



ATENÇÃO:
ATENCIÓN:

1) Verifique todas as peças antes de começar a montagem.

Verifique todas las partes antes de empezar el armado.

2) Ao começar a montagem, não apoie as peças na parede.

Al empezar el armado, no apoyes las partes en la pared.

3) Ao colocar as peças e ferragens de lado, cuidado para não perde-las.

Al poner las piezas y herrages a parte, cuidado para no dañarlas.

4) O móvel deve ser montado no chão, para isso, use a própria caixa para proteger e não danificar o piso.

El mueble suele ser armando al piso, para eso, use la propia caja para protegerlo y no dañar al piso.

5) Comece a montagem seguindo as instruções passo a passo.

Comience el armado siguiendo la instrucciones paso a paso.

6) É de responsabilidade do montador seguir as intrucões desse manual, que são fundamentais para a estrutura do móvel.

Es de responsabilidad del armador seguir las instrucciones de este manual, que son fundamentales para la estructura del mueble.

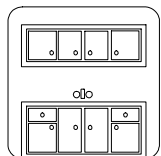

CUIDADOS:
CUIDADOS:

1) A conservação e limpeza deve ser feita com um pano levemente umedecido com água.

La conservación y limpieza debe ser hecha con un trapo levemente humedecido en agua.

2) Não use produtos abrasivos, como saponáceo, detergentes e esponja de aço.

No use productos abrasivos, como saponáceo, detergentes y esponja de acero.

3) Não use cera ou óleo para dar brilho ao móvel.

No use cera o aceites para darle brillo al mueble.



4) Não expor o móvel a interpéries e nem ao calor excessivo.

No exponer el mueble a interperies ni al calor excesivo.

5) Ao terminar a montagem, limpe o ambiente e o móvel.

Al terminar el armado, limpie al ambiente y al mueble.

FERRAMENTAS:
HERRAMIENTAS:

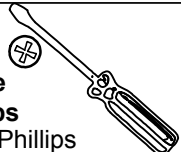





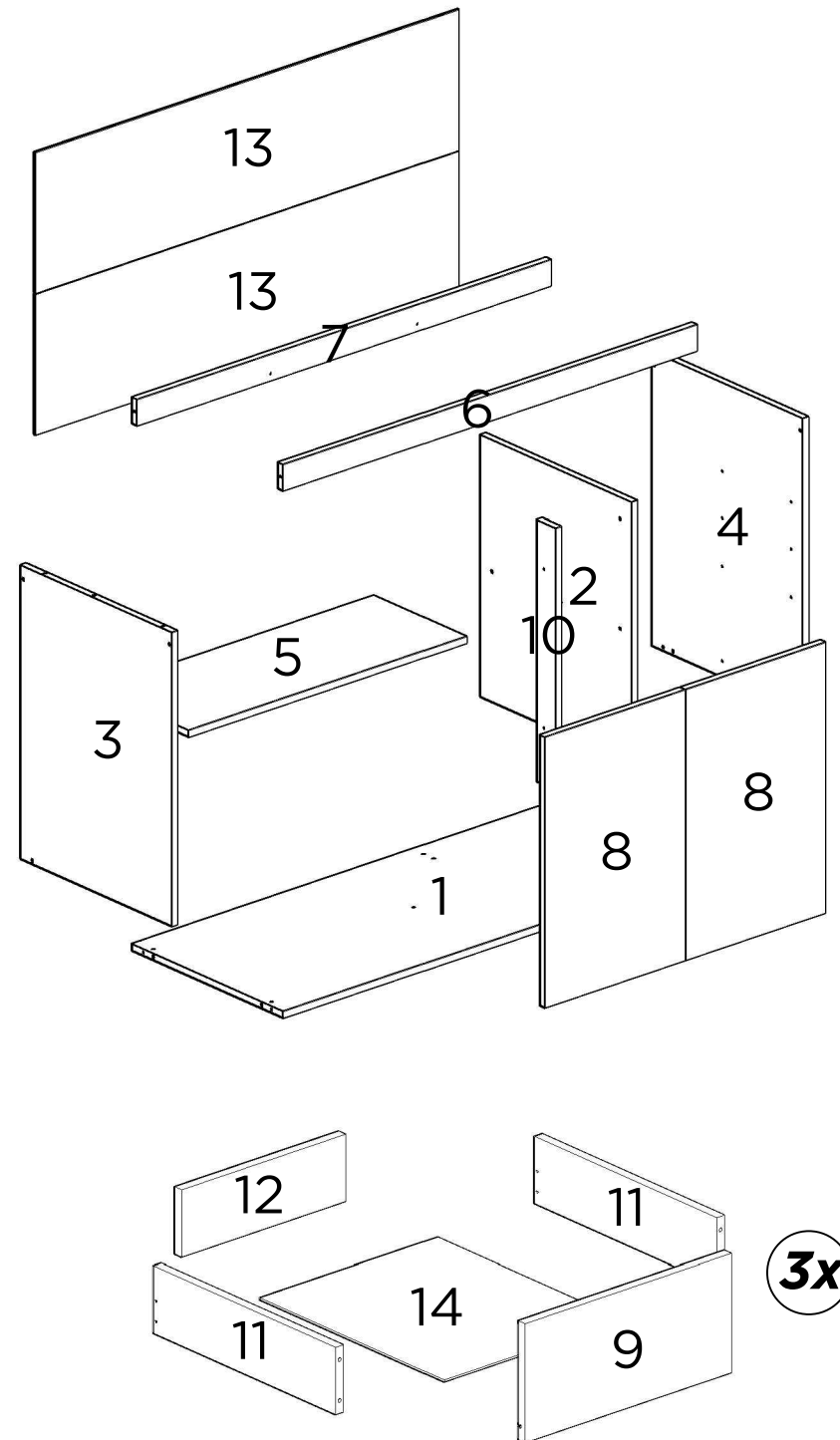



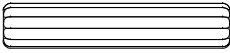



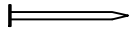

 Parafusadeira Destornillador Eléctrico	 Martelo de borracha Martillo Goma	 Martelo Martillo
 Chave Phillips Llave Phillips	 Trena Cinta métrica	

PEÇAS / PARTS / PIEZAS

Nº No Num	DESCRIÇÃO DESCRIPTION DESCRIPCIÓN	QTD QTY CANT
1	BASE BOTTOM BASE	1
2	DIVISÓRIA DIVISION DIVISIÓN	1
3	LATERAL ESQUERDA LEFT SIDE PANEL LATERAL IZQUIERDA	1
4	LATERAL DIREITA RIGHT SIDE PANEL LATERAL DERECHA	1
5	PRATELEIRA PLATE PANEL REPISA	1
6	TRAVESSA FRONTAL FRONTAL PLATE TRAVESAÑO FRONTAL	1
7	TRAVESSA TRASEIRA BACK PLATE TRAVESAÑO TRASERO	1
8	PORTA DOOR PUERTA	2
9	FRENTE DE GAVETA DRAWER FRONT FRENTE DEL CAJÓN	3
10	PILAstra PILLAR PILAR	1
11	LATERAL DE GAVETA DRAWER SIDE LATERAL DEL CAJÓN	6
12	COSTA DE GAVETA DRAWER BACK TRASERO DEL CAJÓN	3
13	COSTA BACK PANEL TRASERO	2
14	FUNDO DE GAVETA DRAWER BOTTOM PANEL FONDO DEL CAJÓN	3

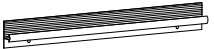

FERRAGENS / HARDWARE / HERRAJES

CÓD CODE COD	DESCRIÇÃO DESCRIPTION DESCRIPCIÓN	QTD QTY CANT
A	 CAVILHA WOODEN DOWEL TARUGO	18
B	 SUPORTE DE PRATELEIRA SHELF SUPPORT SOPORTE DE ESTANTES	4
C	 PARAFUSO 4X14mm SCREW 4X14mm TORNILLO 4X14mm	100
D	 CORREIÇA LATERAL SIDE SLIDE CORREDERA LATERAL	6
E	 PARAFUSO 3,5X25mm SCREW 3,5X25mm TORNILLO 3,5X25mm	8
F	 PARAFUSO 3,5X40mm SCREW 3,5X40mm TORNILLO 3,5X40mm	10
G	 PARAFUSO 5X50mm SCREW 5X50mm TORNILLO 5X50mm	5
H	 PÉ LEG PATA	5
I	 CANTONEIRA DE 2 FUROS METALLIC ANGLE CANTONERA 2 AGUJEROS	2
J	 PREGO NAIL CLAVO	53
K	 PERFIL I PROFILE I PERFIL I	1
L	 CANTONEIRA DE 4 FUROS METALLIC ANGLE CANTONERA 4 AGUJEROS	10
M	 PREGO ANELADO RINGED NAIL CLAVO ANILLADO	12
N	 CORREIÇA GAVETA DRAWER SLIDE CORREDERA DEL CAJÓN	6
O	 PUXADOR PULLER TIRADOR	5
Q	 CALÇO PARA DOBRADIÇA HINGE SHED CALZO DE BISAGRA	4
R	 DOBRADIÇA HINGE BIZAGRA	4
S	 PARAFUSO 3,5X25mm SCREW 3,5X25mm TORNILLO 3,5X25mm	10

UTILIZE A RÉGUA PARA IDENTIFICAR OS PARAFUSOS
USE THE RULER TO IDENTIFY THE SCREWS
UTILICE LA REGLA PARA IDENTIFICAR LOS TORNILLOS





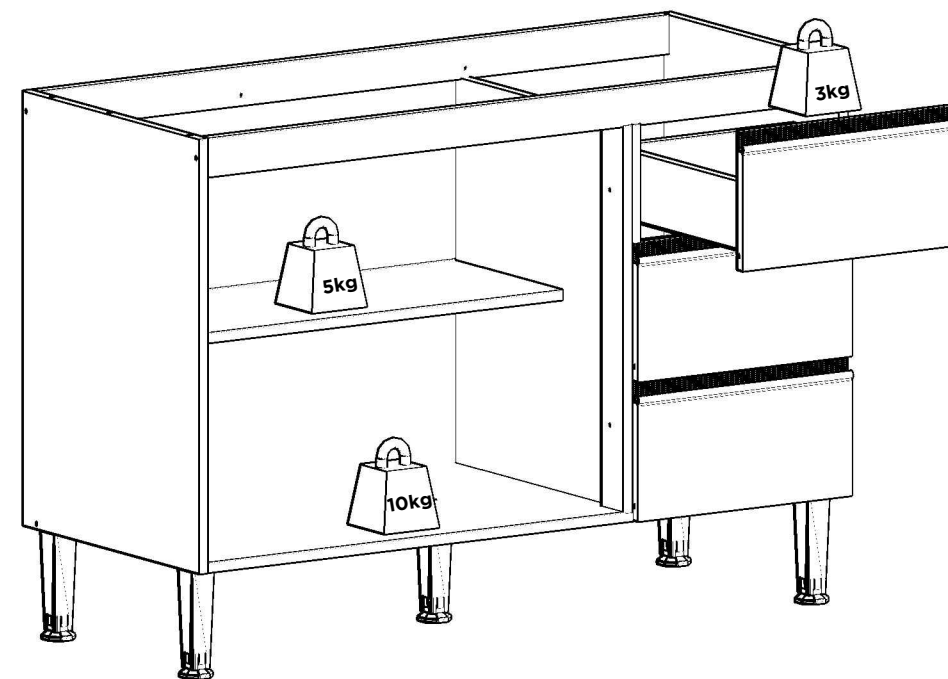

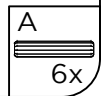
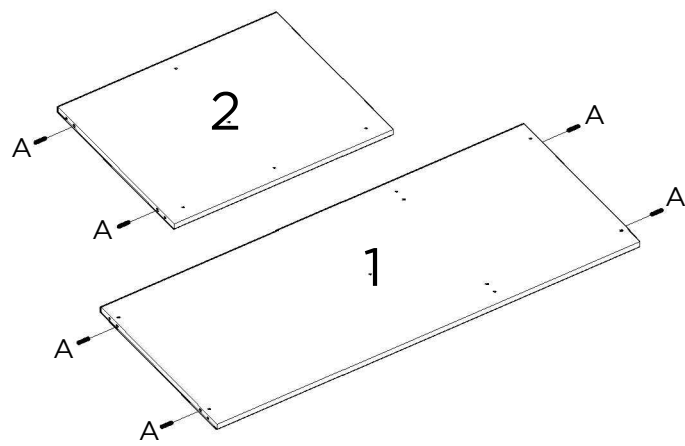
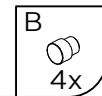
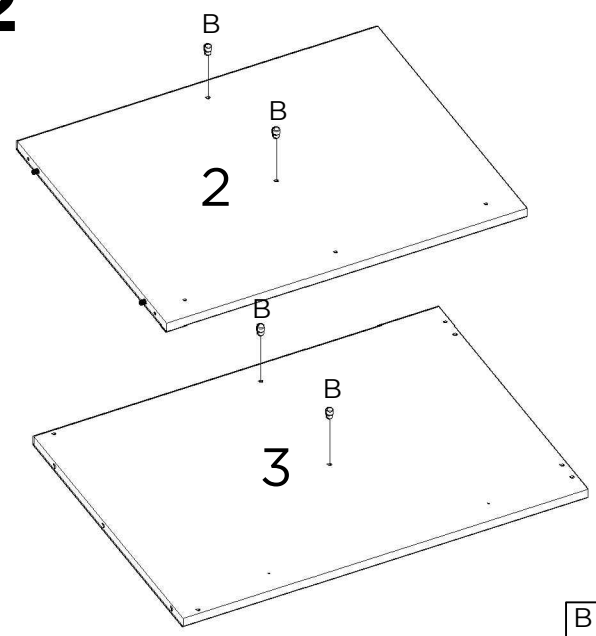
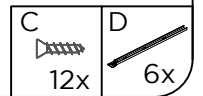
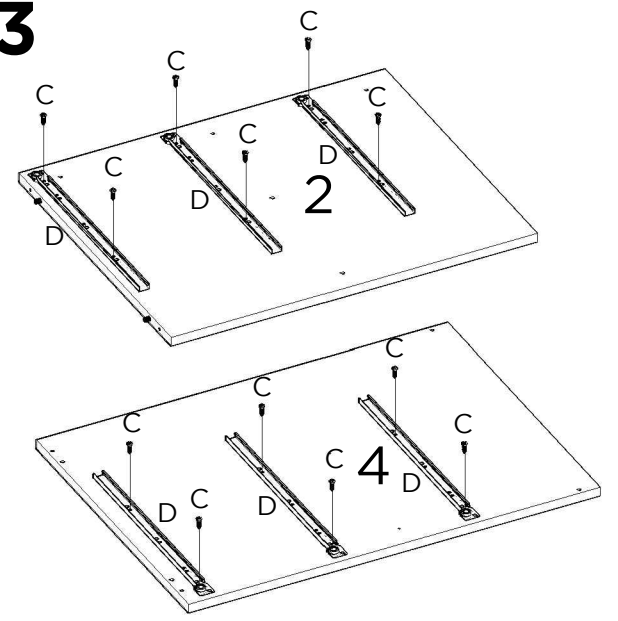
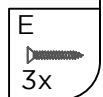
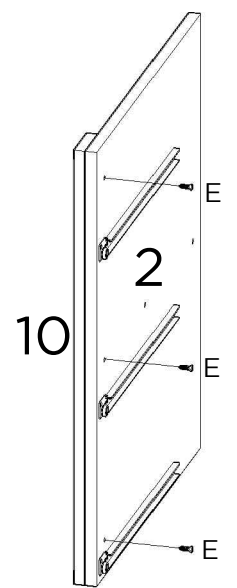
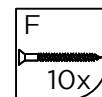
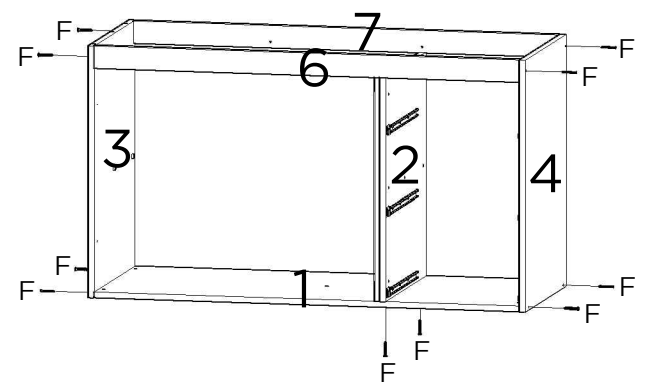
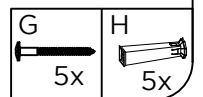
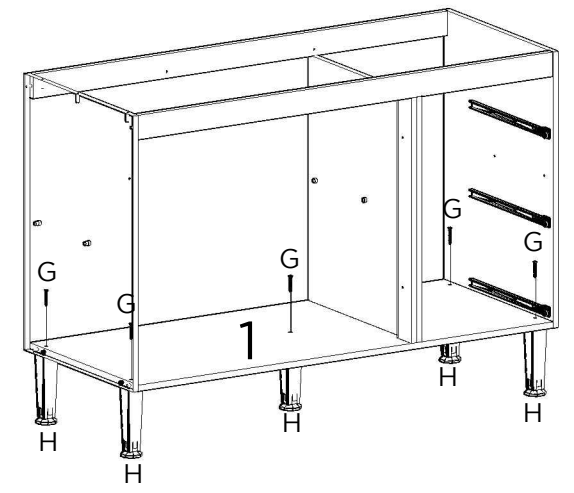
PESO SUPORTADO / WEIGHT SUPPORTED / PESO SOPORTADO

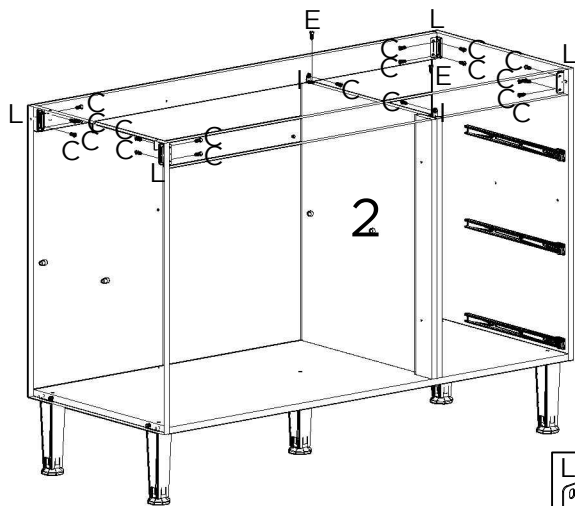

1**2****3****4****5****6**

7





- C**  18x
- E**  2x
- I**  2x

- L**  4x

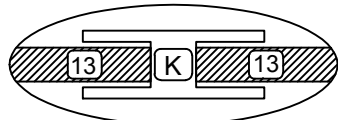
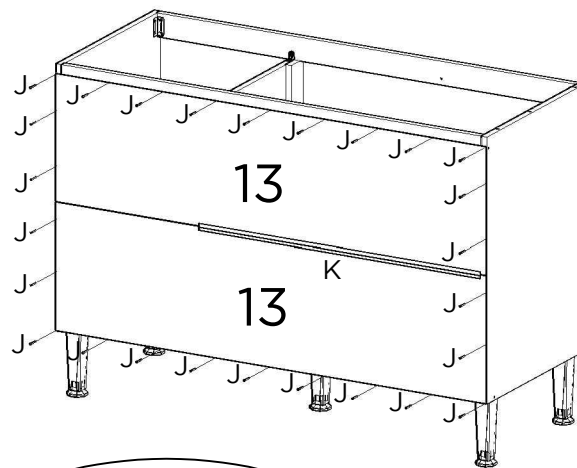
8



- J**  26x
- K**  1x

9

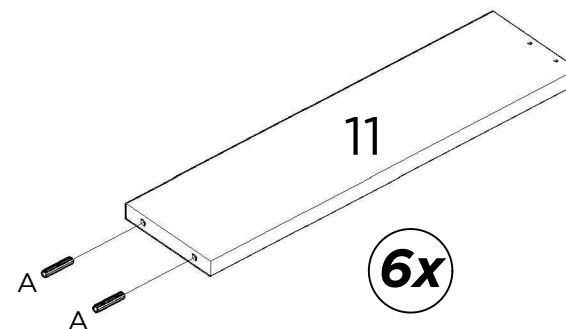



6x

- A**  12x

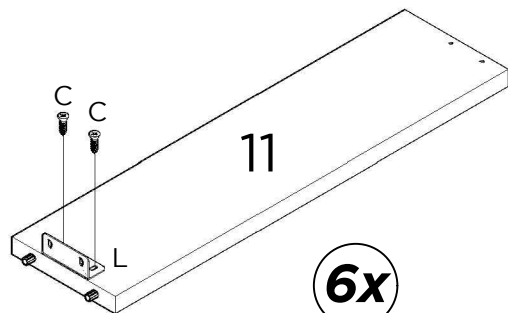
10



6x

- C**  12x
- L**  6x

11

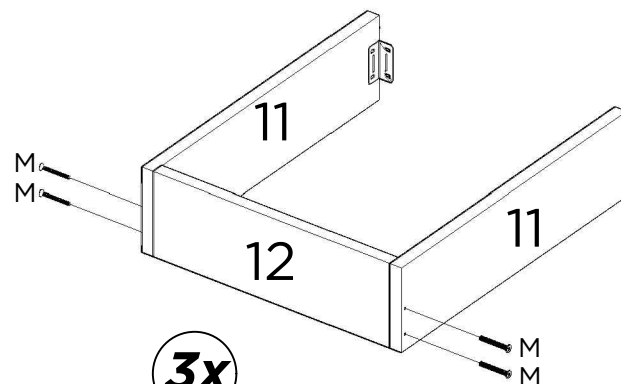

3x

- M**  12x

12

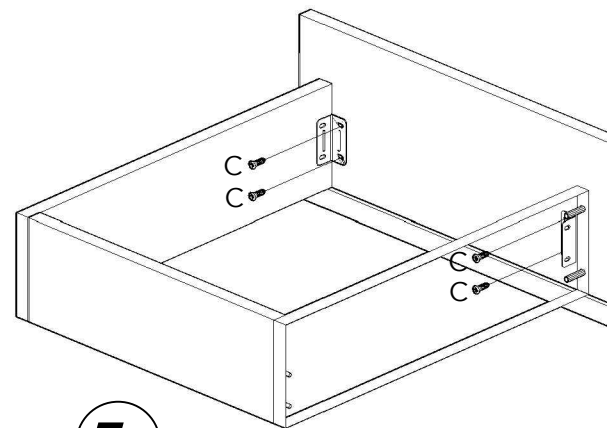

3x

- C**  12x

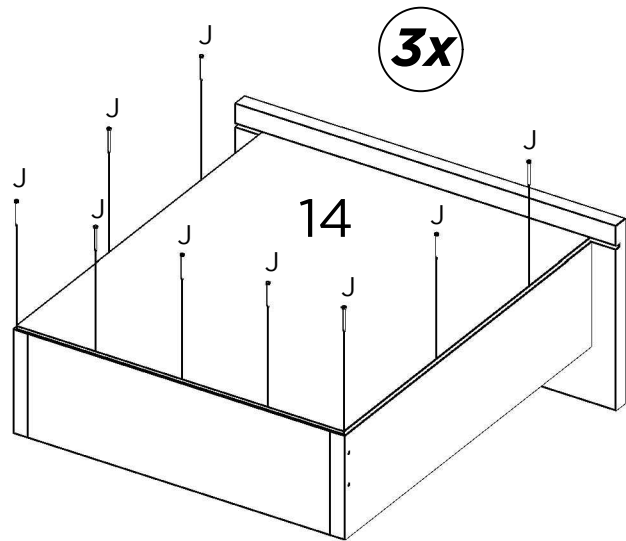
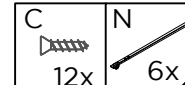
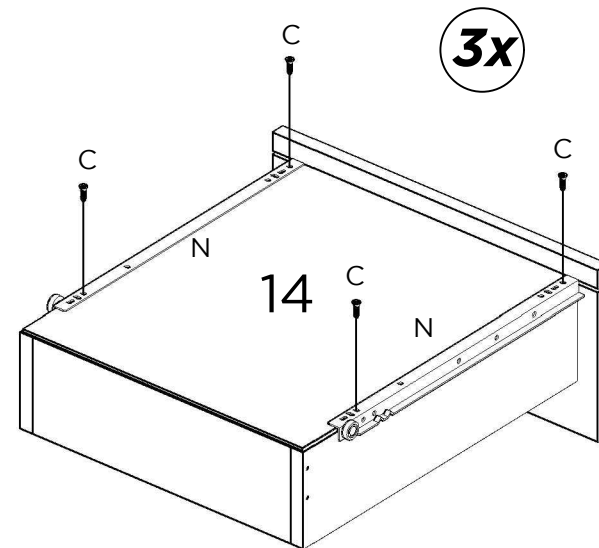
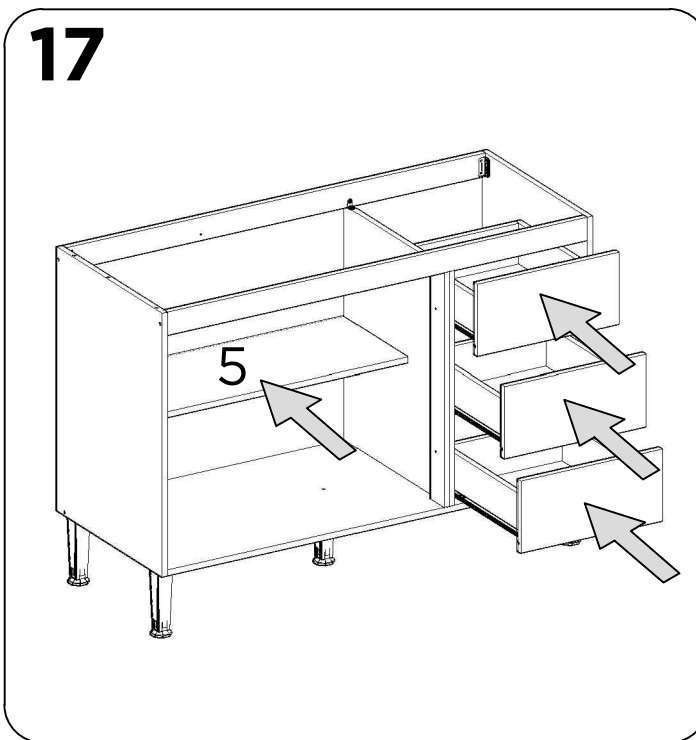
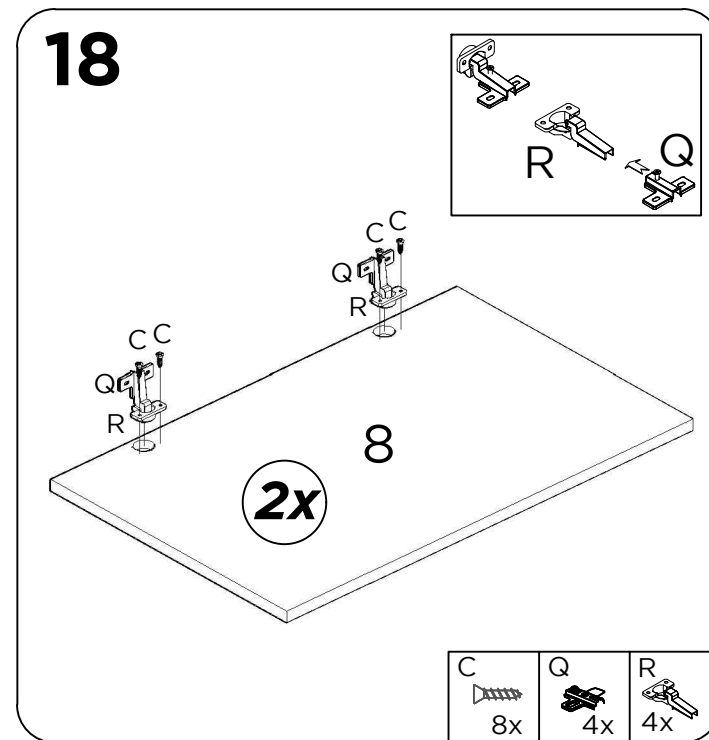
13**14****16****17****18**

19

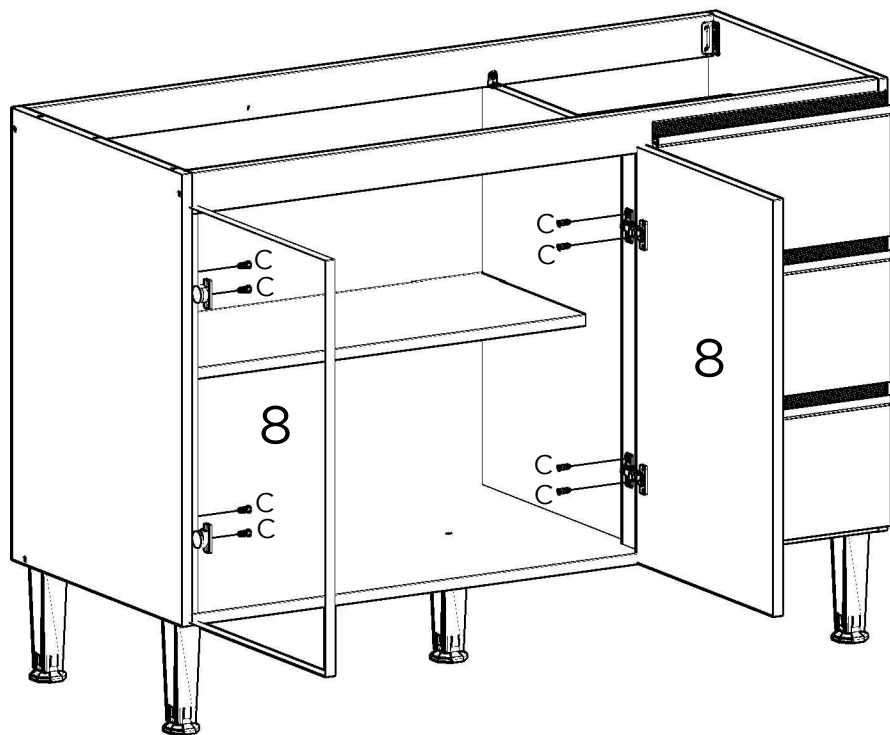

C
8x

20

Instalação dos puxadores conforme modelo adquirido, siga os passos no manual dos puxadores.

Instalación de las manijas según el modelo adquirido, seguir los pasos del manual de manijas.

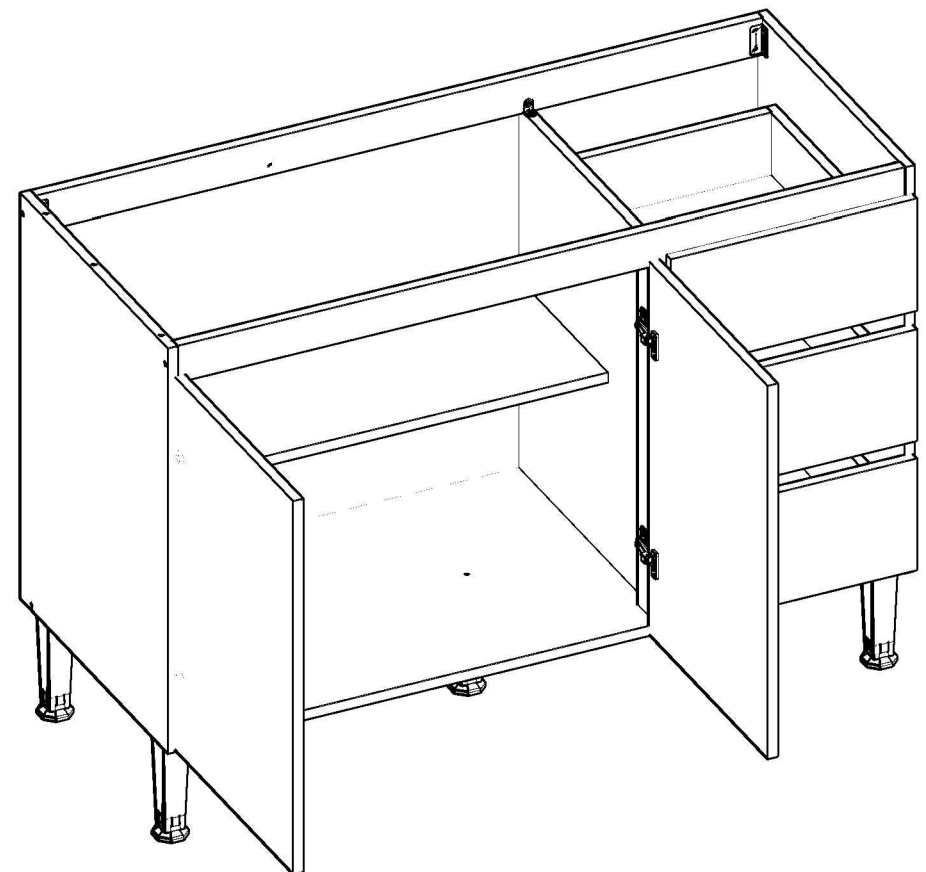

Instalação do puxador. Instalación del tirador

Siga a instrução de montagem do puxador segundo o modelo adquirido. Utilizando as respectivas ferragens.

Siga las instrucciones de montaje del tirador según el modelo adquirido. Usar correctamente la herraje.

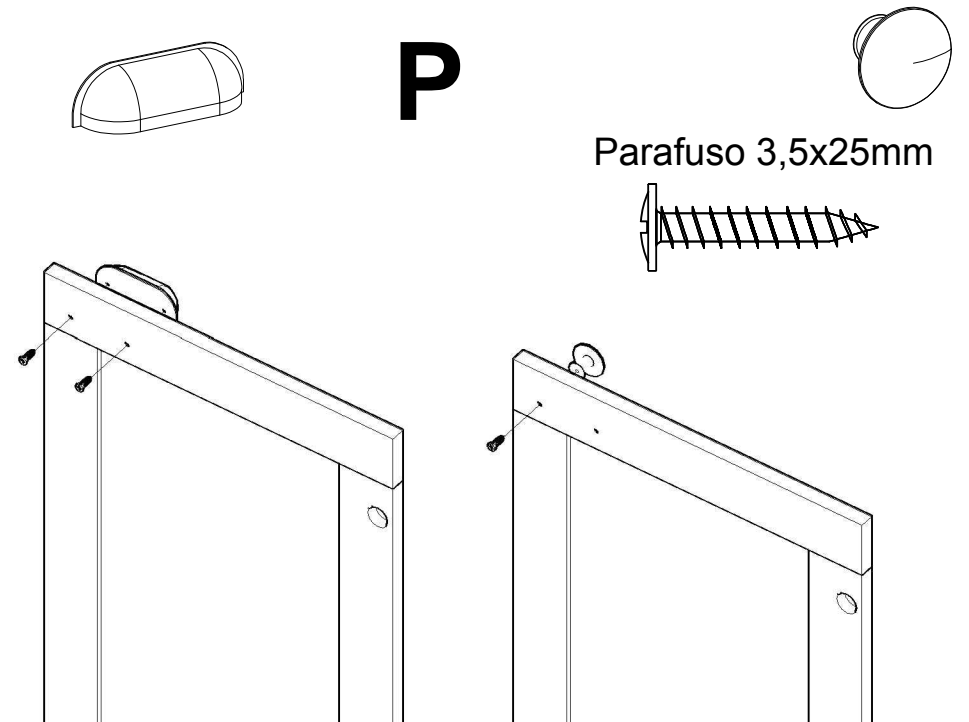
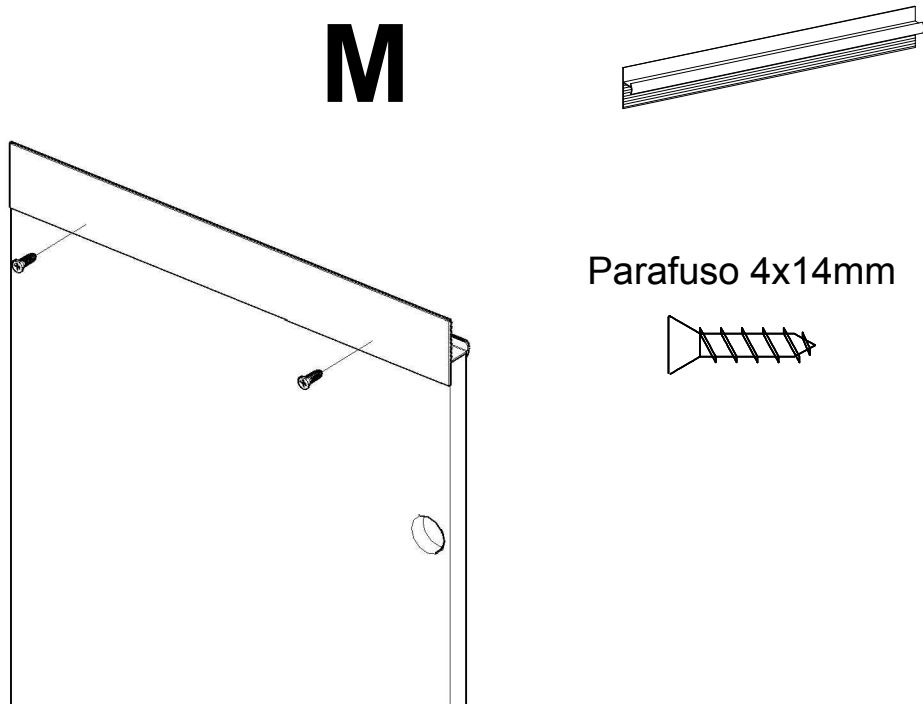
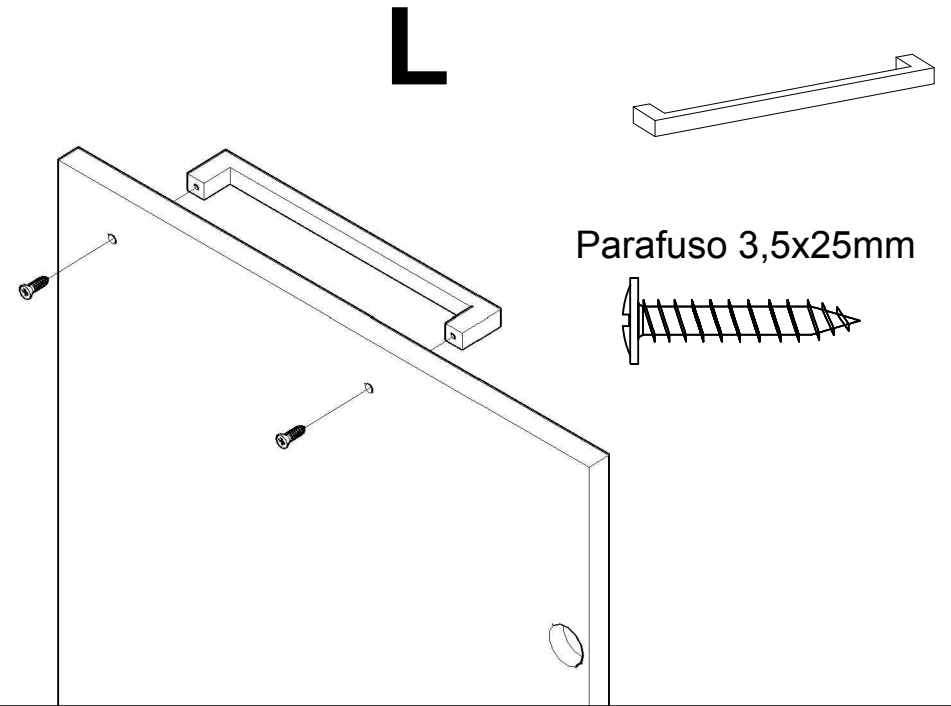
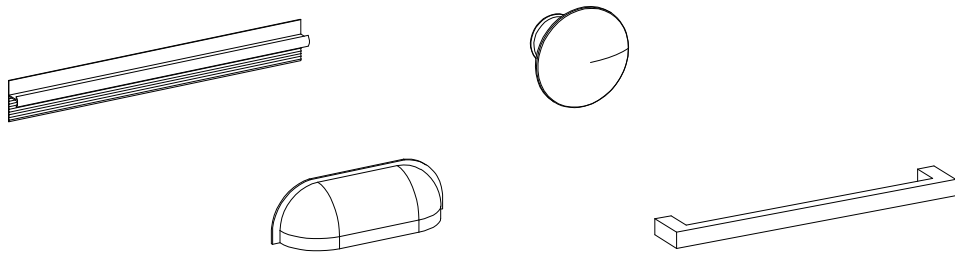

MANUAL DE MONTAGEM / ASSEMBLY INSTRUCTIONS / PLANO DE ARMADO

Antes de montar o móvel, leia com atenção o manual de montagem!
Before assembling the furniture, carefully read the assembly instructions!
Antes de armar el mueble, lea con atención el manual de ensamble!

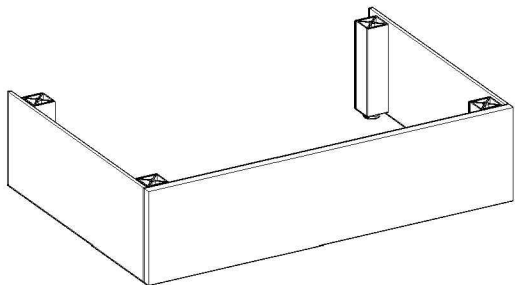

Ref.: RODAPÉ BASEBOARD ZÓCALO

genialflex
ambientes incríveis para todos

Parabéns! Você comprou um produto de excelente qualidade, fabricado com chapa de madeira de MDP ou MDF, extraída de florestas renováveis. Possui alta resistência e design atual.

Congratulations! You have purchased a product of excellent quality, made from MDP or MDF wood veneer, extracted from renewable forests. It has high strength and current design.

Felicitaciones! Usted compró a un producto de excelente calidad, fabricado con placa de madera de MDP o MDF, proveniente de florestas renovables. Tiene alta resistencia y diseño actual.



ATENÇÃO ATTENTION ATENCIÓN

- 1)** Verifique todas as peças antes de começar a montagem.
Check all parts before starting assembly.
Verifique todas las partes antes de empezar el armado.
- 2)** Ao começar a montagem, não apoie as peças na parede.
When starting the assembly, do not support the parts on the wall.
Al empezar el armado, no apoyes las partes en la pared.
- 3)** Ao colocar as peças e ferragens de lado, cuidado para não perde-las.
When placing parts and hardware aside, be careful not to lose them.
Al poner las piezas y herrages a parte, cuidado para no dañarlas.
- 4)** O móvel deve ser montado no chão, para isso, use a própria caixa para proteger e não danificar o piso.
The furniture must be mounted on the floor, to do this, use the box itself to protect and not damage the floor.
El mueble suele ser armado al piso, para eso, use la propia caja para protegerlo y no dañar al piso.
- 5)** Comece a montagem seguindo as instruções passo a passo.
Begin assembly by following the step-by-step instructions.
Comience el armado siguiendo la instrucciones paso a paso.
- 6)** É de responsabilidade do montador seguir as intruções desse manual, que são fundamentais para a estrutura do móvel.
It's the assembler's responsibility to follow the instructions in this manual, which are fundamental to the structure of the furniture.
Es de responsabilidad del armador seguir las instrucciones de este manual, que son fundamentales para la estructura del mueble.

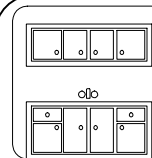

CUIDADOS CARE CUIDADO

- 1)** A conservação e limpeza deve ser feita com um pano levemente umedecido com água.
Care and cleaning should be done with a cloth slightly moistened with water.
La conservación y limpieza debe ser hecha con un trapo levemente humedecido en agua.
- 2)** Não use produtos abrasivos, como saponáceo, detergentes e esponja de aço.
Do not use abrasive products, such as soap, detergents and steel sponge.
No use productos abrasivos, como saponáceo, detergentes y esponja de acero.
- 3)** Não use cera ou óleo para dar brilho ao móvel.
Do not use wax or oil to shine the furniture.
No use cera o aceites para darle brillo al mueble.
- 4)** Não expor o móvel a interpéries e nem ao calor excessivo.
Do not expose the furniture to weather or excessive heat.
No exponer el mueble a interperies ni al calor excesivo.
- 5)** Ao terminar a montagem, limpe o ambiente e o móvel.
When the assembly is finished, clean the room and the furniture.
Al terminar el armado, limpie al ambiente y al mueble.

FERRAMENTAS / TOOLS / HERRAMIENTAS



MARTELO
HAMMER
MARTILLO



MARTELO DE BORRACHA
RUBBER HAMMER
MARTILLO GOMA

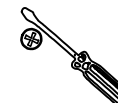

CHAVE PHILLIPS
PHILLIPS SCREWDRIVER
LLAVE PHILLIPS



TRENA
MEASURING TAPE
CINTA MÉTRICA



PARAFUSADEIRA
DRILL/ELETRIC
SCREWDRIVER
DESTORNILLADOR
ELÉCTRICO

PEÇAS / PARTS / PIEZAS

Nº No Num	DESCRIÇÃO DESCRIPTION DESCRIPCIÓN	QTD QTY CANT
1	RODAPÉ FRONTAL FRONTAL FOOTBOARD ZOCALO FRONTAL	1
2	RODAPÉ LATERAL SIDE FOOTBOARD ZOCALO LATERAL	2

FERRAGENS / HARDWARE / HERRAJES

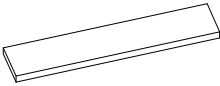
CÓD CODE COD	DESCRIÇÃO DESCRIPTION DESCRIPCIÓN	QTD QTY CANT
1	 FITA DUPLA FACE DOUBLE SIDED TAPE CINTA DE DOS LADOS	6

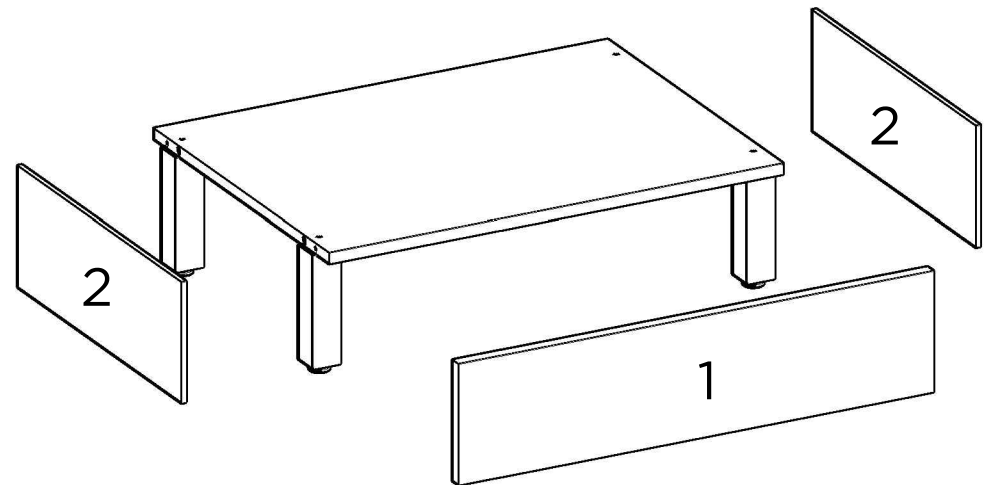

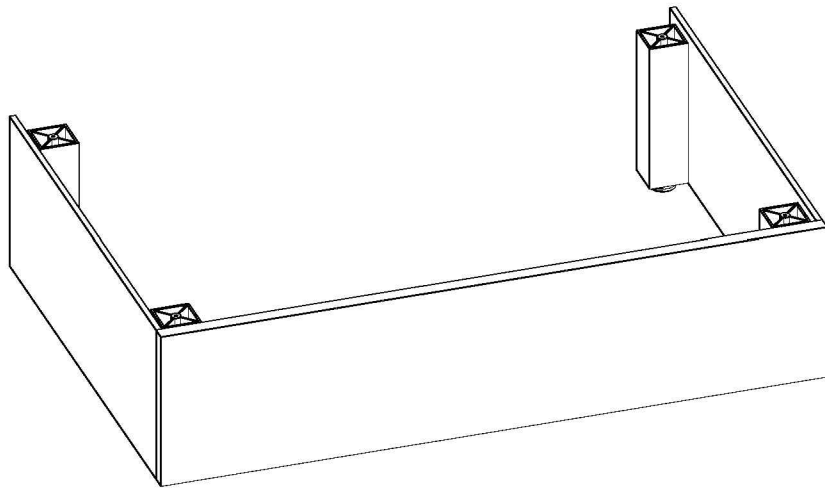
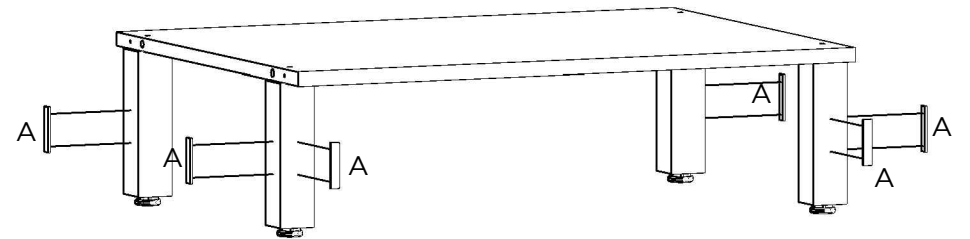
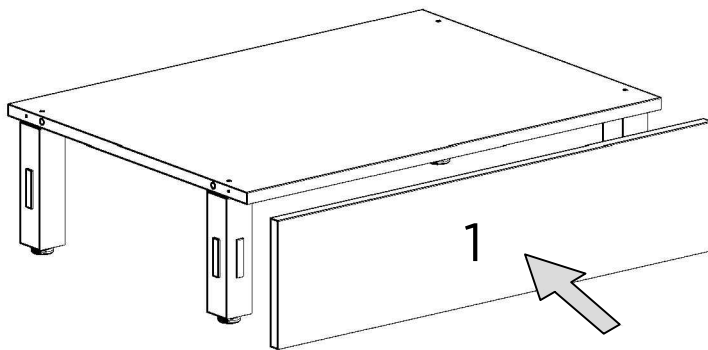
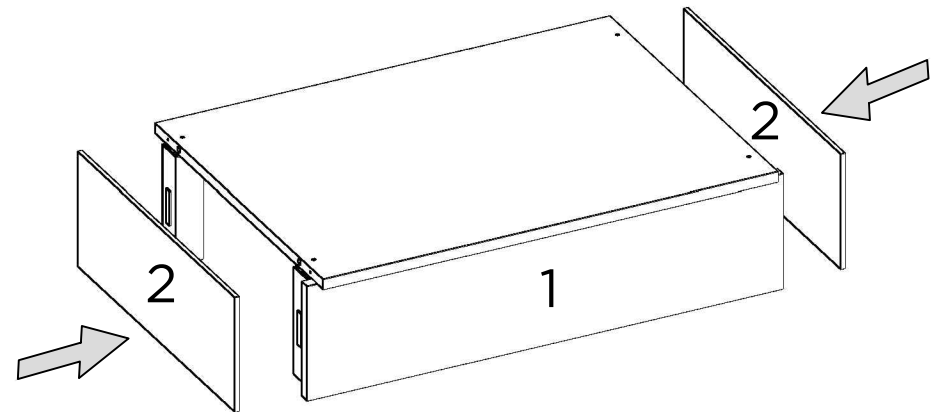
1**2****A**
6x**3****4**

MANUAL DE MONTAGEM / PLANO DE ARMADO

Parabéns! Você comprou um produto de excelente qualidade, fabricado com chapa de madeira de MDP ou MDF, extraída de florestas renováveis. Possui alta resistência e design atual.

Felicitaciones! Usted compró a un producto de excelente calidad, fabricado con placa de madera de MDP o MDF, proveniente de florestas renovables. Tiene alta resistencia y diseño actual.

Antes de montar o móvel, leia com atenção o manual de montagem!
Antes de armar el mueble, lea con atención el manual de ensamble!



ATENÇÃO:
ATENCIÓN:

- 1) Verifique todas as peças antes de começar a montagem.**
Verifique todas las partes antes de empezar el armado.
- 2) Ao começar a montagem, não apoie as peças na parede.**
Al empezar el armado, no apoyes las partes en la pared.
- 3) Ao colocar as peças e ferragens de lado, cuidado para não perde-las.**
Al poner las piezas y herrages a parte, cuidado para no dañarlas.
- 4) O móvel deve ser montado no chão, para isso, use a própria caixa para proteger e não danificar o piso.**
El mueble suele ser armado al piso, para eso, use la propia caja para protegerlo y no dañar al piso.
- 5) Comece a montagem seguindo as instruções passo a passo.**
Comience el armado siguiendo la instrucciones paso a paso.
- 6) É de responsabilidade do montador seguir as intruções desse manual, que são fundamentais para a estrutura do móvel.**
Es de responsabilidad del armador seguir las instrucciones de este manual, que son fundamentales para la estructura del mueble.

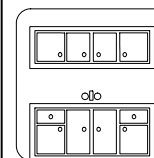

- 1) A conservação e limpeza deve ser feita com um pano levemente umedecido com água.**
La conservación y limpieza debe ser hecha con un trapo levemente humedecido en agua.
- 2) Não use produtos abrasivos, como saponáceo, detergentes e esponja de aço.**
No use productos abrasivos, como saponáceo, detergentes y esponja de acero.

CUIDADOS:

CUIDADOS:

- 3) Não use cera ou óleo para dar brilho ao móvel.**
No use cera o aceites para darle brillo al mueble.
- 4) Não expor o móvel a interperies e nem ao calor excessivo.**
No exponer el mueble a interperies ni al calor excesivo.
- 5) Ao terminar a montagem, limpe o ambiente e o móvel.**
Al terminar el armado, limpie al ambiente y al mueble.

FERRAMENTAS:
HERRAMIENTAS:



Martelo de borracha
Martillo Goma



Martelo
Martillo



Chave Phillips
Llave Phillips

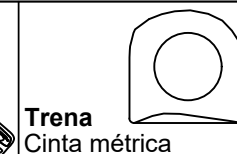

Trena
Cinta métrica

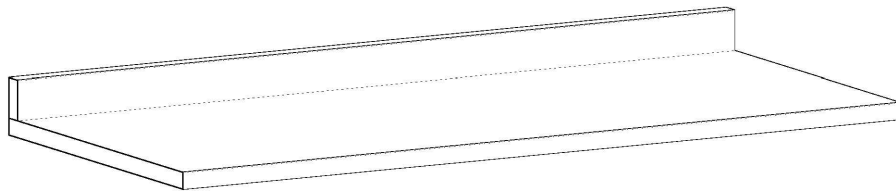

Ref.: 0298

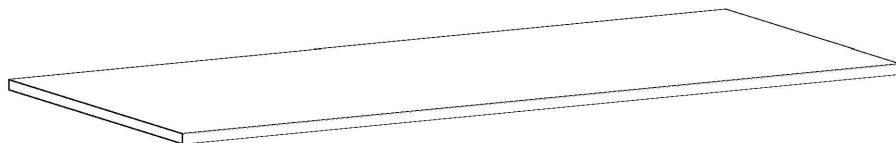

Ref.: 0299

Antes de começar a montagem certifique-se que as caixas estão em perfeitas condições.

Antes de empezar el armado asegúrese que las cajas estén en perfectas condiciones.



genialflex
ambientes incríveis para todos

Ref.: 0298

LISTA DE PEÇAS / LISTA DE PIEZAS

Nº	Descrição / Descripción	Qtd. Cant.
1	Tampo / Tablero	1
2	Espelho / Espejo	1

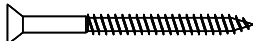
LISTA DE FERRAGENS / LISTA DE HERRAJES

ITEM ITEM	DESCRIÇÃO / DESCRIPCIÓN	QTD. CANT.
P1	 PARAFUSO 3,5X14 TORNILLO 3,5X14	16
P16	 PARAFUSO 4X60 TORNILLO 4X60	4
S1	 CHAPA "L" 2 FUROS PLACA "L" 2 AGUJEROS	8

USE A RÉGUA PARA IDENTIFICAR OS PARAFUSOS
UTILICE LA REGLA PARA IDENTIFICAR LOS TORNILLOS

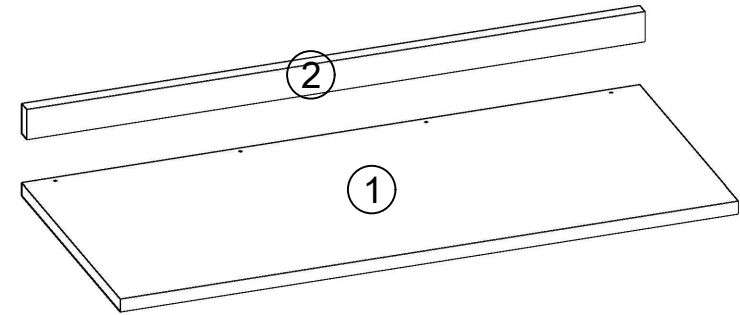
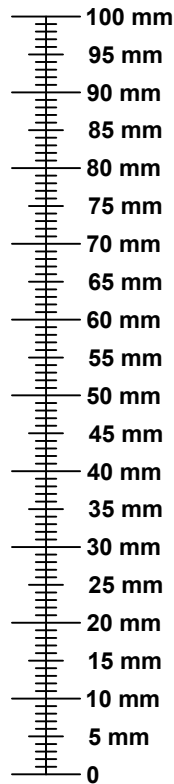

1

FIXE O ESPELHO (2) NO TAMPO (1)
FIJE EL ESPEJO (2) EN EL TABLERO (1)

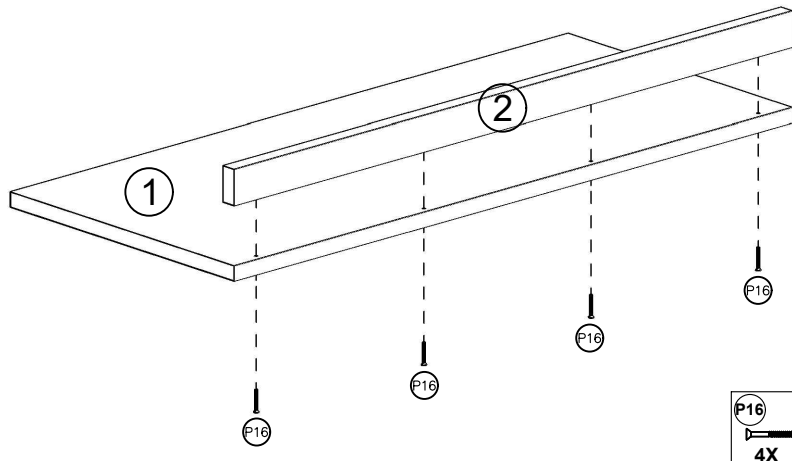

2

FIXE O TAMPO (1) NO BALCÃO
FIJE EL TABLERO (1) EN EL MUEBLE BAJO

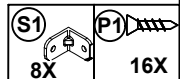
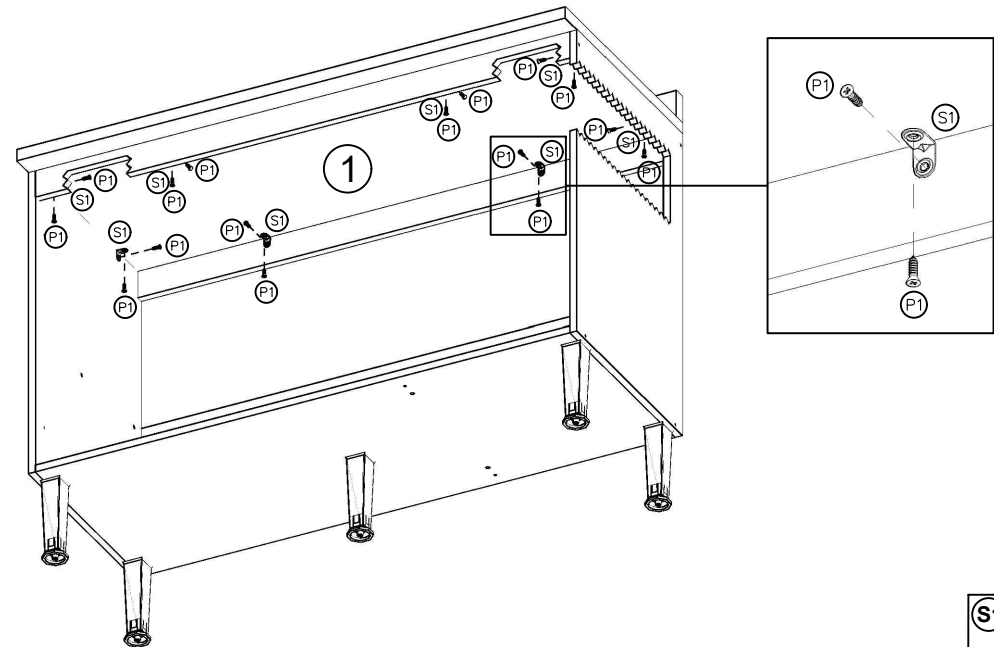

Ref.: 0299

LISTA DE PEÇAS / LISTA DE PIEZAS		
Nº	Descrição / Descripción	Qtd. Cant.
1	Tampo / Tablero	1

LISTA DE FERRAGENS / LISTA DE HERRAJES		
ITEM ITEM	DESCRIÇÃO / DESCRIPCIÓN	QTD. CANT.
P1	 PARAFUSO 3,5X14 TORNILLO 3,5X14	16
S1	 CHAPA "L" 2 FUROS PLACA "L" 2 AGUJEROS	8

USE A RÉGUA PARA IDENTIFICAR OS PARAFUSOS
UTILICE LA REGLA PARA IDENTIFICAR LOS TORNILLOS

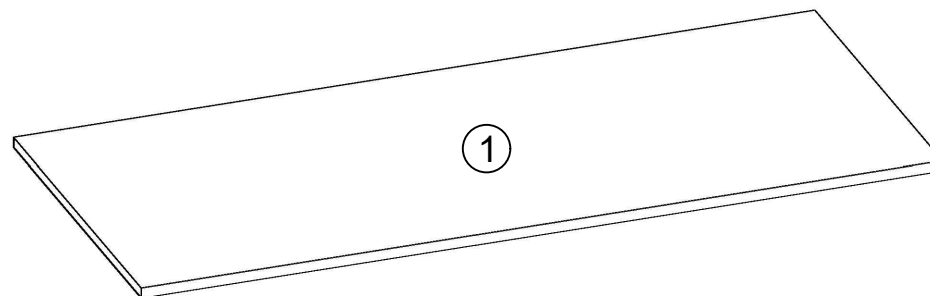
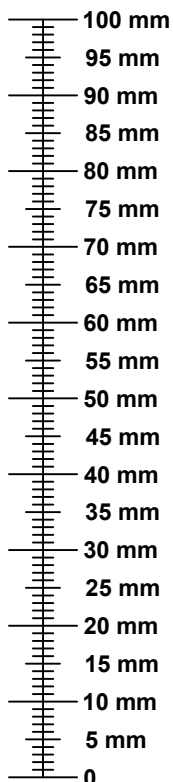

1
FIXE O TAMPO (1) NO BALCÃO
FIJE EL TABLERO (1) EN EL
MUEBLE BAJO

