

# ASSEMBLY INSTRUCTIONS

## MANUAL DE MONTAGEM / INSTRUCCIONES DE ARMADO

Alasca bar  
Bar Alasca  
Bar Alasca

Reference 190397 | Revise 00  
Referência 190397 | Revisão 00  
Referencia 190397 | Revisión 00

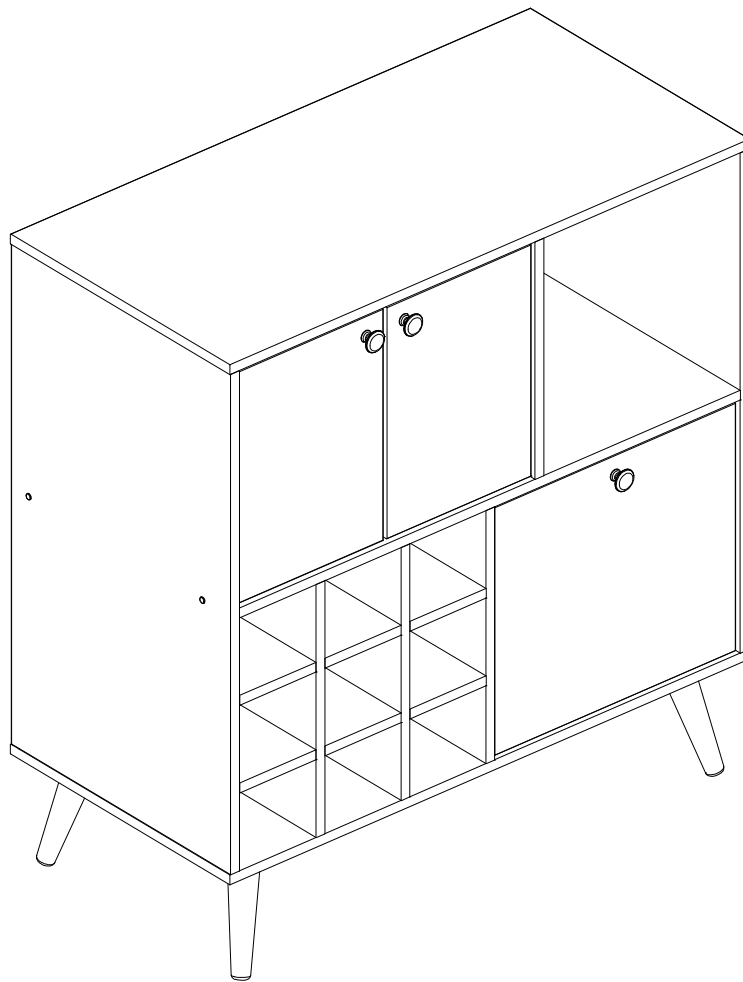

### YOU WILL NEED / VOCÊ VAI PRECISAR DE / USTED NECESITARÁ

#### Tools not supplied / Ferramentas não fornecidas / Herramientas no incluidas

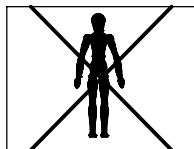

1 Person  
1 Pessoa  
1 Persona

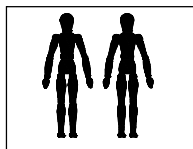

2 People  
2 Pessoas  
2 Personas

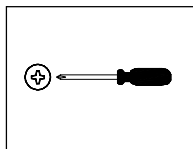

Screwdriver Phillips  
Chave Phillips  
Destornillador cruz

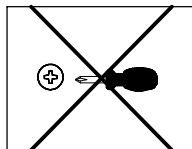

Small screwdriver Phillips  
Chave Phillips Menor  
Destornillador cruz menor

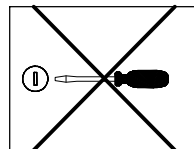

Screwdriver slotted  
Chave fenda  
Destornillador plano

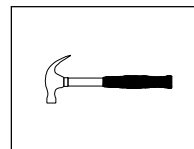

Hammer  
Martelo  
Martillo

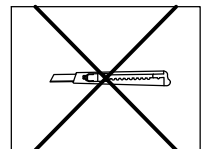

Stilet  
Estilete  
Estilete

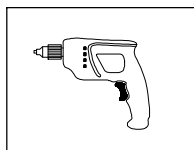

Drill machine  
Furadeira  
Taladro

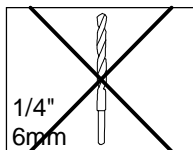

Drill bit  
Broca  
Taladro

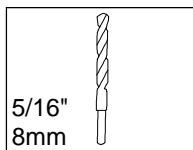

5/16"  
8mm  
Drill bit  
Broca  
Taladro

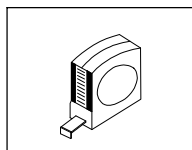

Measuring tape  
Trena  
Cinta de medición

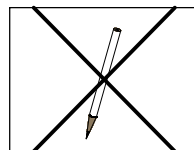

Pencil  
Lápis  
Lápis

**NOTES:** The separation of the accessories before you start the assembly will facilitate the same. In case of doubt on the size of the screws and bolts, use the ruler to bottom of page 3.

**NOTAS:** A separação dos acessórios antes de iniciar a montagem facilitará a mesma. Em caso de dúvida no tamanho dos parafusos e cavilhas, utilize a régua ao final da página 3.

**NOTAS:** La separación de los accesorios antes de comenzar el armado facilitará el mismo. En caso de duda sobre el tamaño de los tornillos y taquetes, utilice la regla al pie de página 3.

MAXIMUM RECOMMENDED WEIGHT  
BEING THIS EVENLY DISTRIBUTED

PESO MÁXIMO RECOMENDADO SENDO  
ESTE DISTRIBUÍDO UNIFORMEMENTE

PESO MÁXIMO RECOMENDADO SIENDO  
ESTE UNIFORMEMENTE DISTRIBUIDO

	LB	KG
<b>A</b>	33	15
<b>B</b>	11	5
<b>C</b>	6,6	3
<b>D</b>	4,4	2

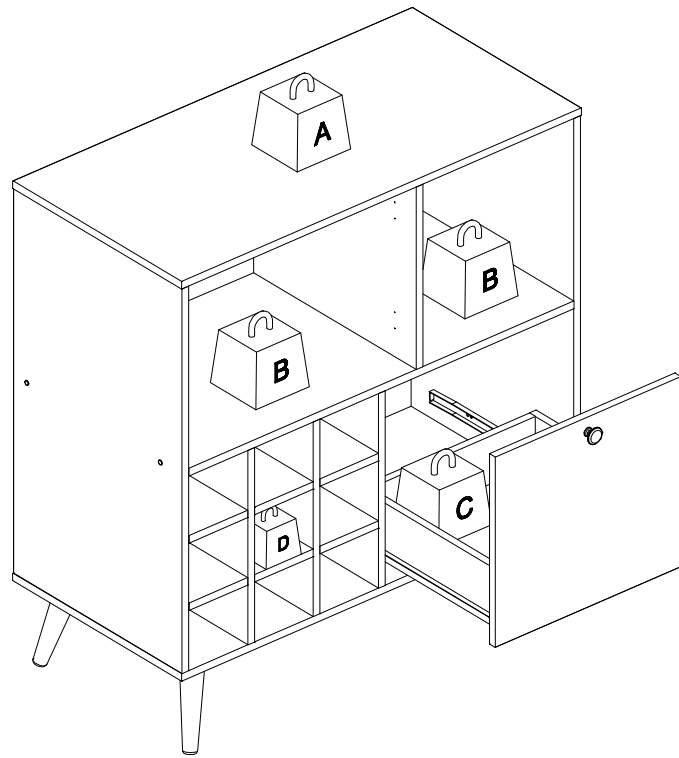





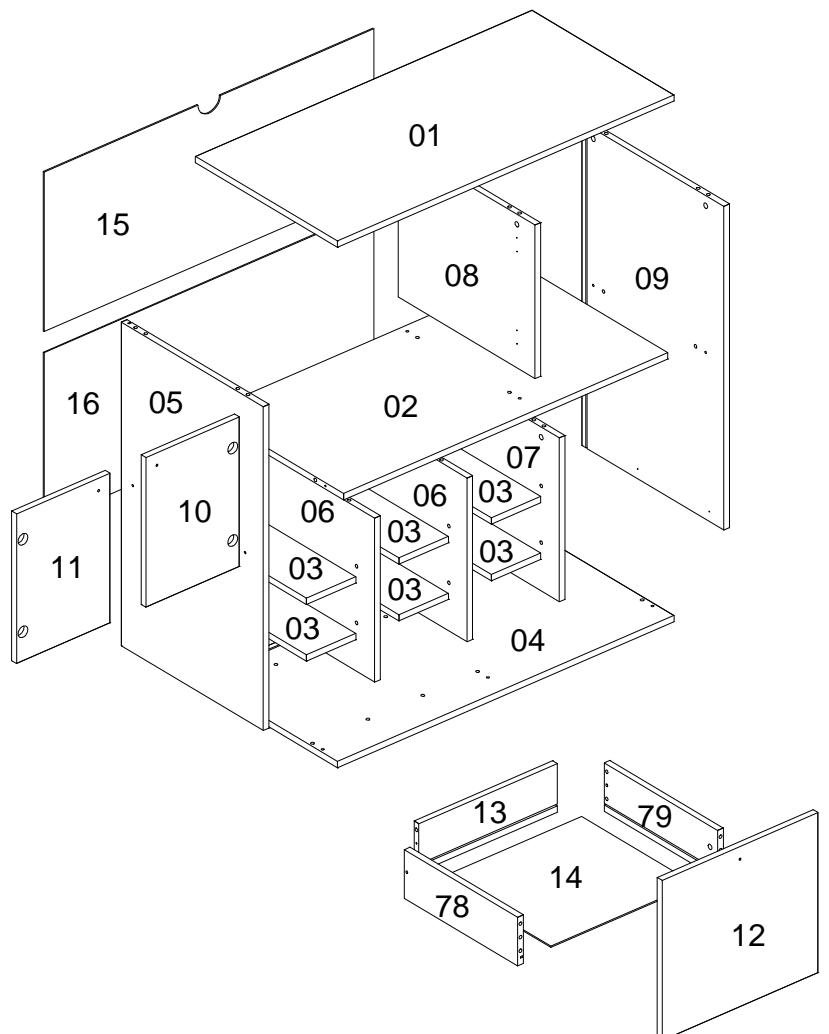





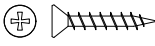
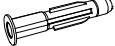







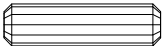

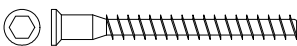

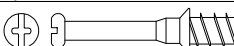

Nº	Measures Inches	Medidas cm	Qty./Qtd.
01	35" 3/8 x 17" 1/2 x 5/8	90 x 44,5 x 1,5	1
02	34" 1/8 x 16" 7/8 x 5/8	86,7 x 42,9 x 1,5	1
03	5" 1/4 x 16" 7/8 x 5/8	13,2 x 42,9 x 1,5	6
04	35" 3/8 x 17" 1/2 x 5/8	90 x 44,5 x 1,5	1
05	30" 1/8 x 17" 1/2 x 5/8	76,5 x 44,5 x 1,5	1
06	15" 1/4 x 16" 7/8 x 5/8	38,7 x 42,9 x 1,5	2
07	15" 1/4 x 16" 7/8 x 5/8	38,7 x 42,9 x 1,5	1
08	14" 1/4 x 16" 7/8 x 5/8	36,3 x 42,9 x 1,5	1
09	30" 1/8 x 17" 1/2 x 5/8	76,5 x 44,5 x 1,5	1
10	13" 7/8 x 9" 7/8 x 5/8	35,4 x 25 x 1,5	1
11	13" 7/8 x 9" 7/8 x 5/8	35,4 x 25 x 1,5	1
12	14" 7/8 x 16" 3/8 x 5/8	37,9 x 41,7 x 1,5	1
13	14" 5/8 x 4" 1/2 x 5/8	37 x 11,5 x 1,5	1
14	15" 1/8 x 13" 7/8 x 1/8	38,4 x 35,4 x 0,3	1
15	34" 3/4 x 14" 7/8 x 1/8	88,2 x 37,7 x 0,3	1
16	34" 3/4 x 15" 7/8 x 1/8	88,2 x 40,2 x 0,3	1
78	14" x 4" 1/2 x 5/8	35,5 x 11,5 x 1,5	1
79	14" x 4" 1/2 x 5/8	35,5 x 11,5 x 1,5	1

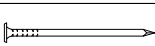
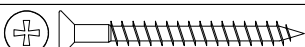
**PARTS IDENTIFICATION**  
**IDENTIFICAÇÃO DAS PEÇAS / IDENTIFICACIÓN DE LAS PIEZAS**

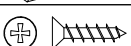

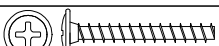
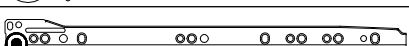
# IDENTIFICATION OF ACCESSORIES IDENTIFICAÇÃO DOS ACESSÓRIOS/ IDENTIFICACIÓN DE ACCESORIOS

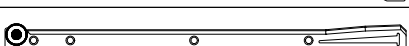
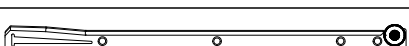
A		Flanged head screw / Parafuso flangeado / Tornillo de cabeza flangeada	5,0x60 mm	1
A1		Glue / Cola / Pegamento	13 g	1
A8		Flat head screw / Parafuso chato / Tornillo de cabeza plana	3,5x20 mm	8
B3		Bushing / Bucha expansiva / Tapón	8x50 mm	1
B7		Metalic bracket / Suporte de metal / Suporte de metal	-	1
B8		Shelf bracket / Suporte de prateleira / Suporte de repisa	10x15 mm	2
B12		Support Foot / Suporte Pé / Pie Soporte	-	4
B13		Nut / Porca / Tuerca	5/16	4
C1		Metal claw / Garra de metal / Garra metal	-	5
D5		Hinge shim / Calço dobradiça / Bisagra de calce	-	4
D6		Metal hinge super high / Dobradiça super alta / Bisagra alta	26 mm	4
E		Wooden dowel / Cavilha / Taquete	8x30 mm	36
E3		Shelf bracket / Suporte de prateleira / Suporte de repisa	8x7 mm	24
F8		Cup holder / Porta taça / Sostenedor de taza	-	2
G		Structural screw / Parafuso estrutural / Tornillo estructural	5,0x50 mm	4
H		Allen key / Chave allen / Liave allen	3 mm	1
H18		Handle / Puxador Grace / Tirador	-	3
I		Structural screw cover/Tampa parafuso estrutural/Tapa tornillo estructural	-	4
i7		Foot / Pé / Pie	165 mm	4
J		Simple minifix screw / Haste minifix simples / Tornillo minifix simple	-	10
L		Drum lock / Tambor minifix / Tambor minifix	12 mm	10
M		Bore patch adhesive / Tapa furo adesivo / Tapones adhesivo	-	10
N		Nail / Prego / Clavo	10x10	5
O		Flat head screw / Parafuso chato / Tornillo de cabeza plana	4,5x45 mm	10
o1		Triangular support / Suporte triangular / Soporte triangular	-	8
P5		Flat head screw / Parafuso chato especial / Tornillo de cabeza plana	3,5x14 mm	8
S		Pan head screw / Parafuso panela / Tornillo de pan	3,5x14 mm	40
T		Flanged head screw / Parafuso flangeado / Tornillo de cabeza flangeada	3,5x25 mm	3
VA		Metallic slide the left field / Corrediça lateral esquerda / Corredera lateral izquierda	350 mm	1
VB		Metallic slide the right field / Corrediça lateral direita / Corredera lateral derecha	350 mm	1
VC		Drawer slide left / Corrediça gaveta esquerda / Corredera izquierda cajón	350 mm	1
VD		Drawer slide right / Corrediça gaveta direita / Corredera derecha cajón	350 mm	1



PRE-ASSEMBLE  
PRÉ-MONTAGEM / PRE ARMADO

01

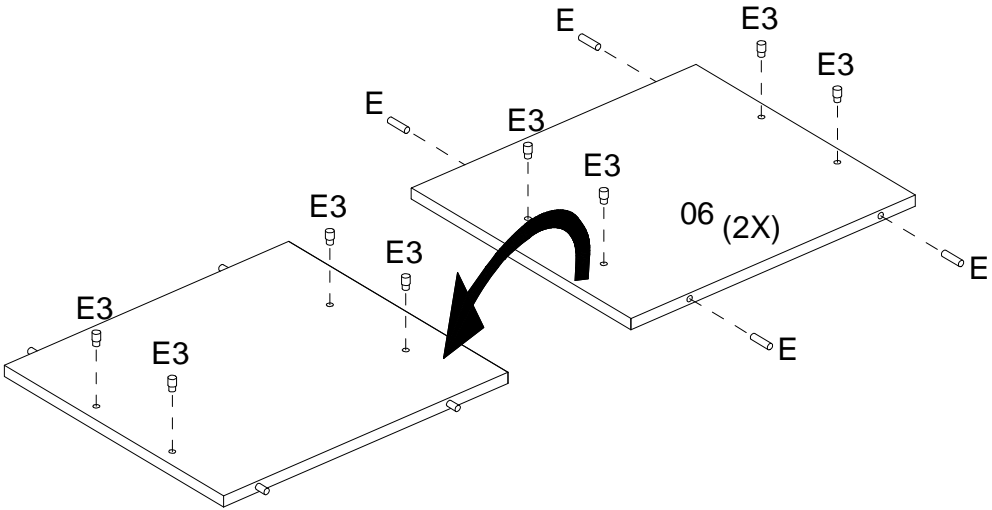
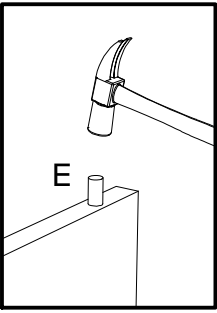

02

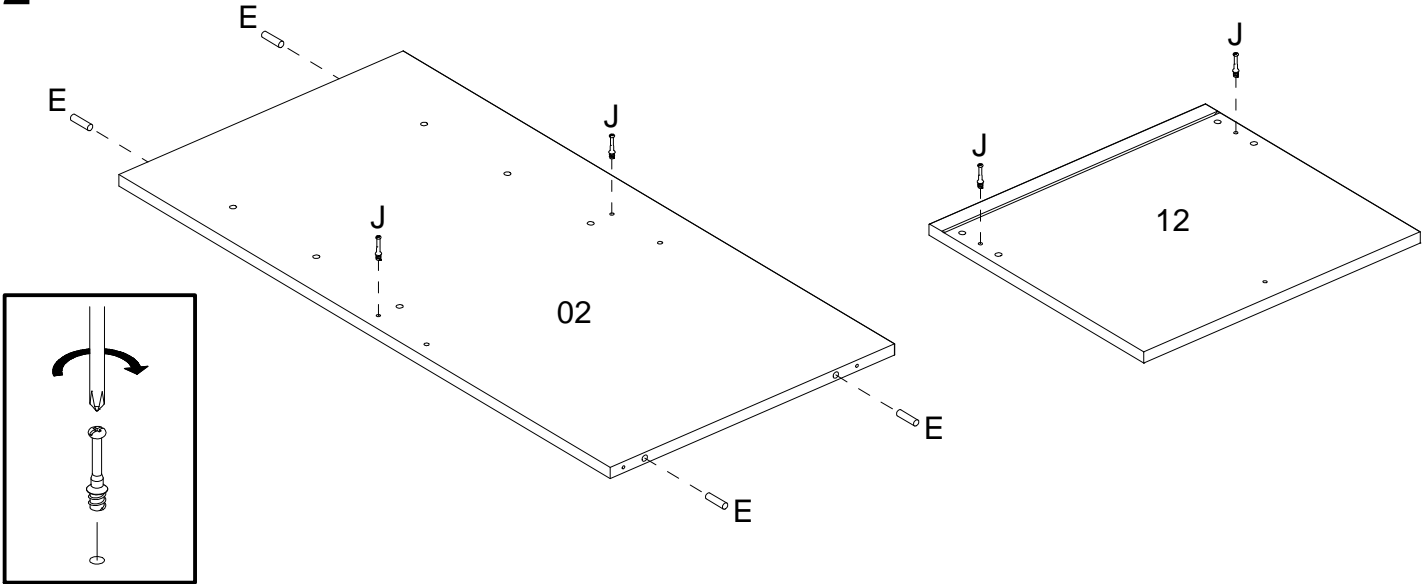

03

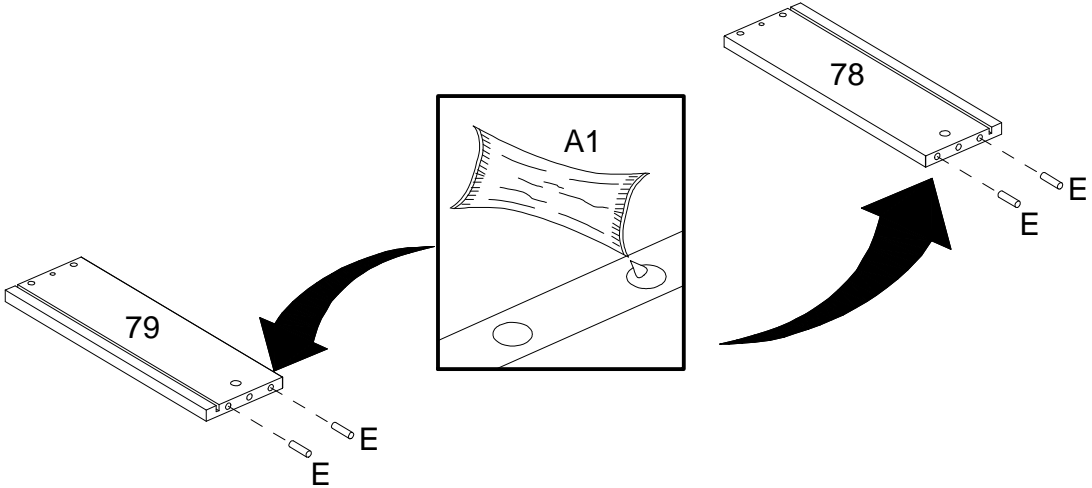

04

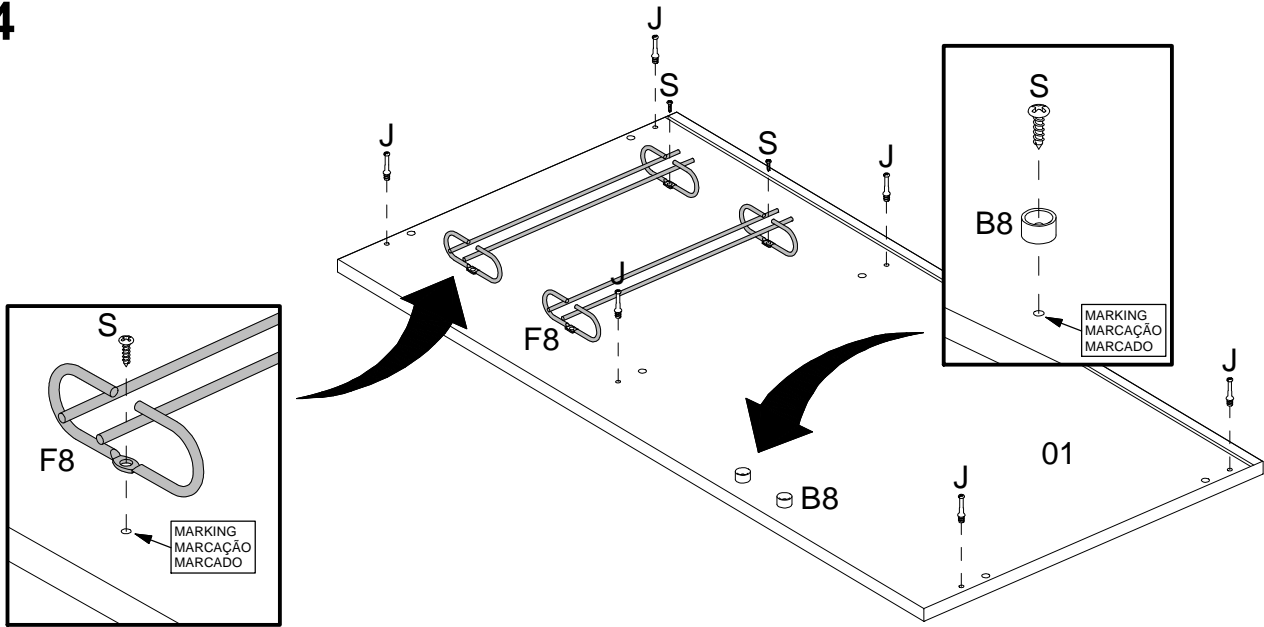

05

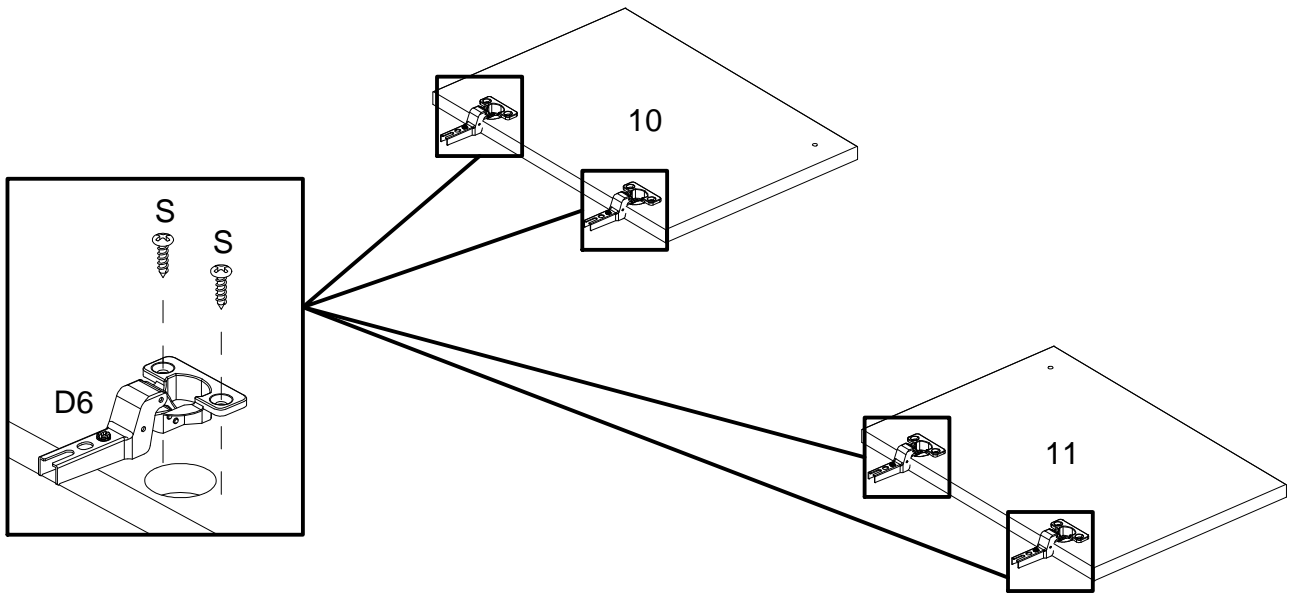

06

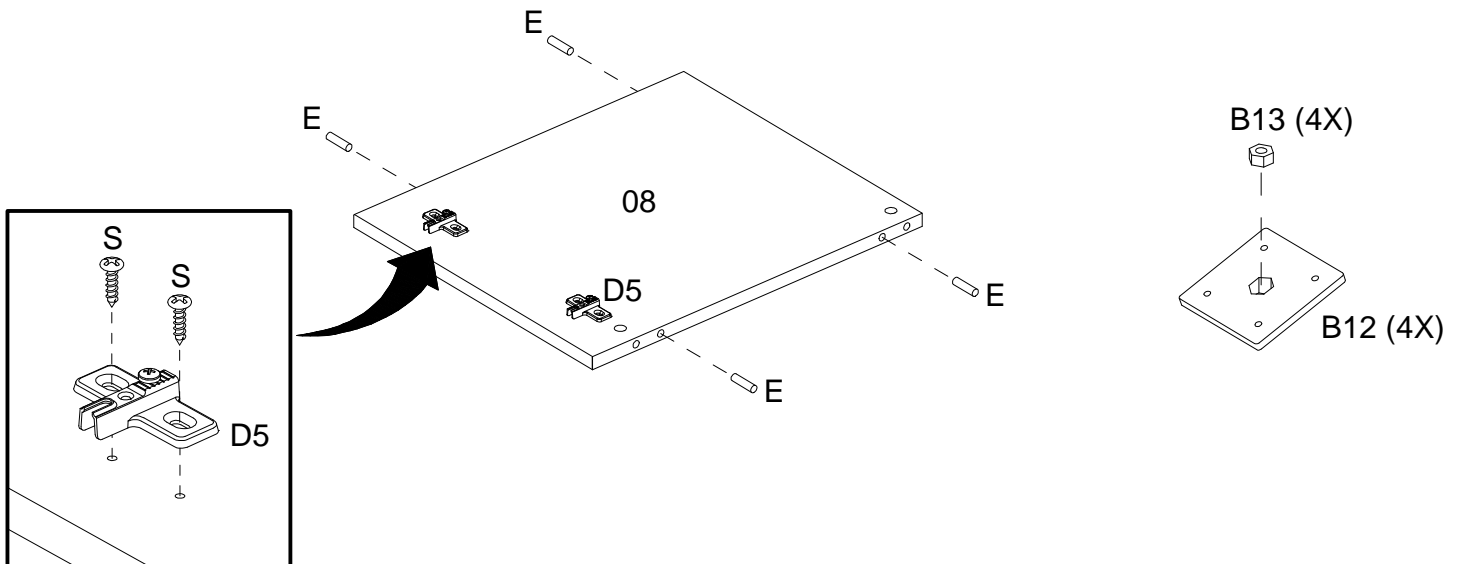

07

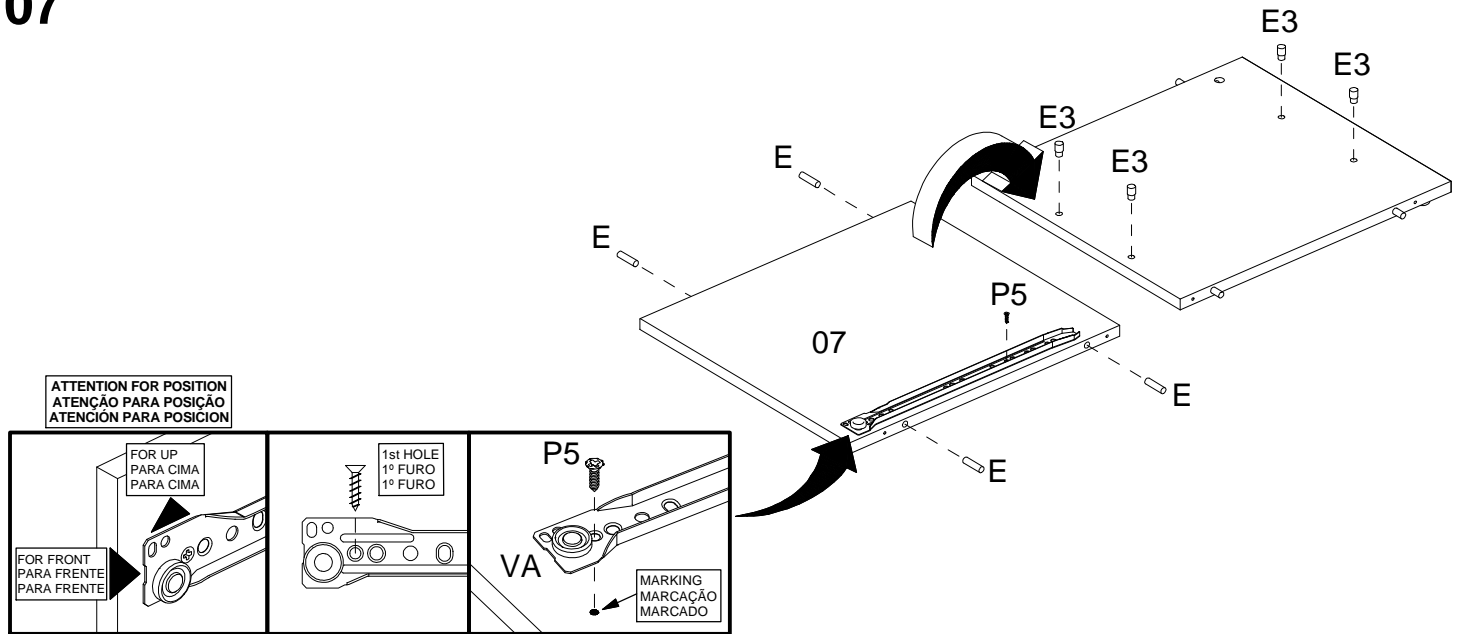

08

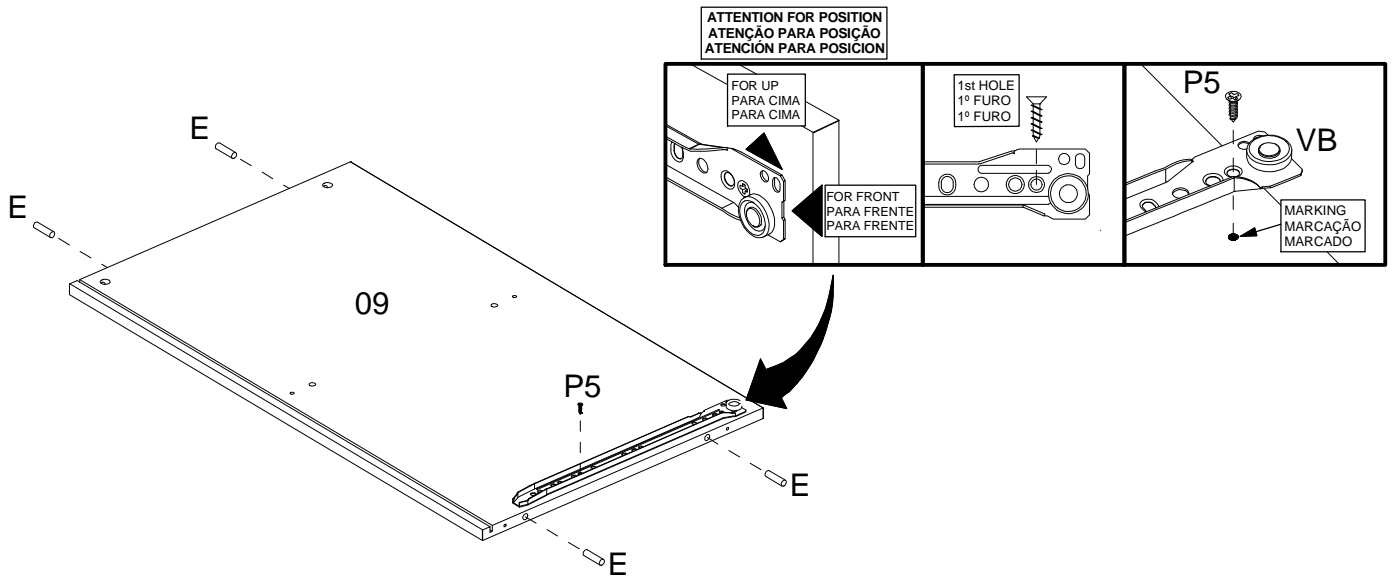

09

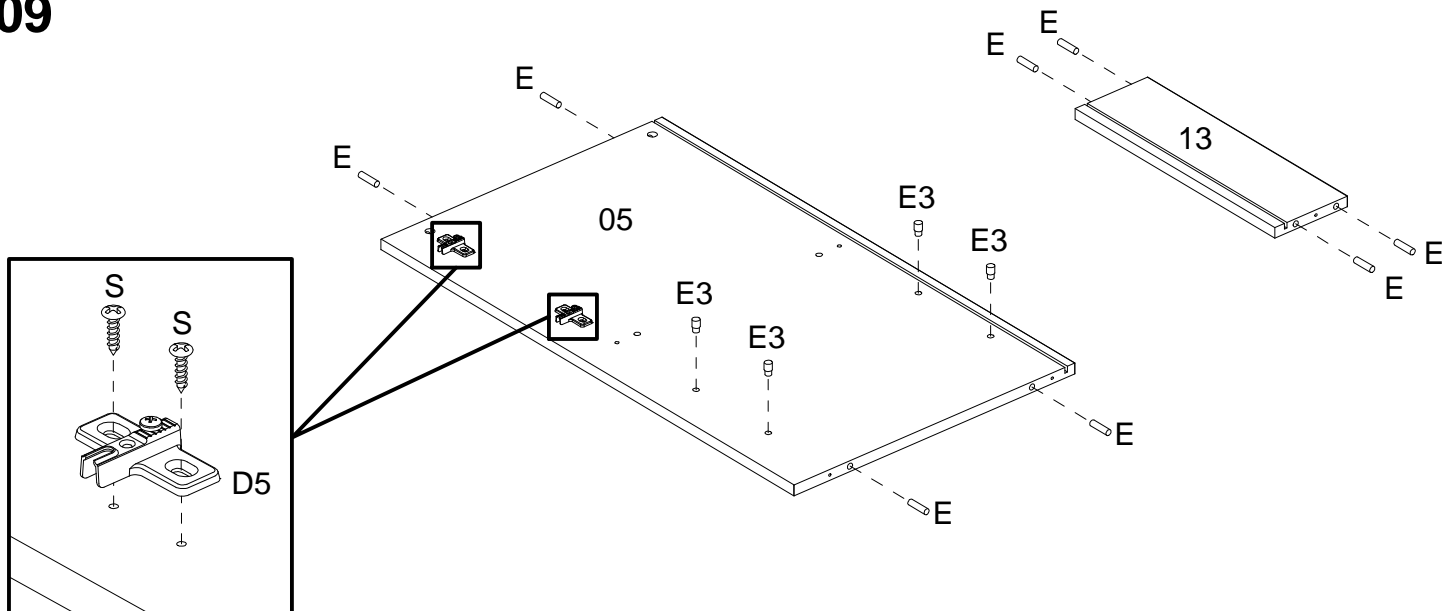

ASSEMBLY  
MONTAGEM / ARMADO

10

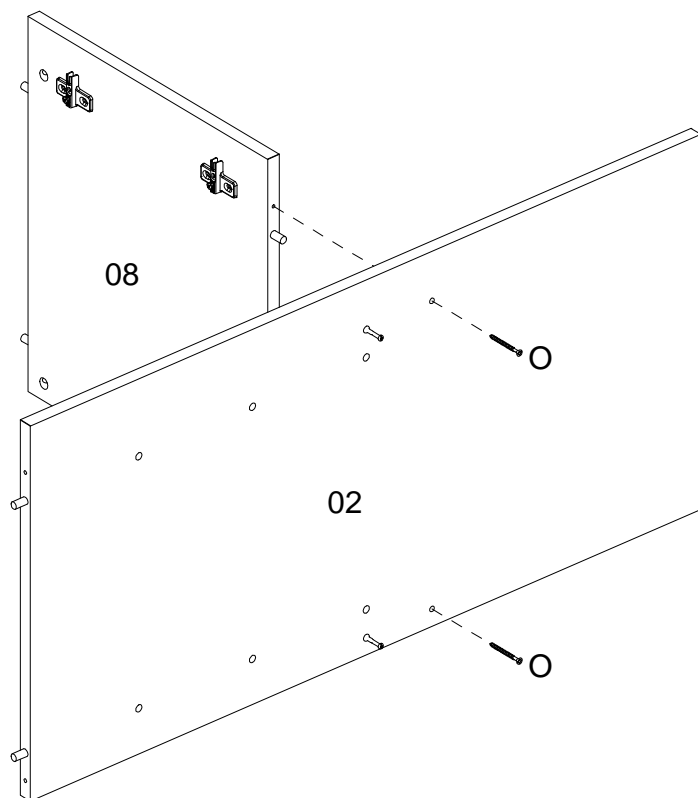

11

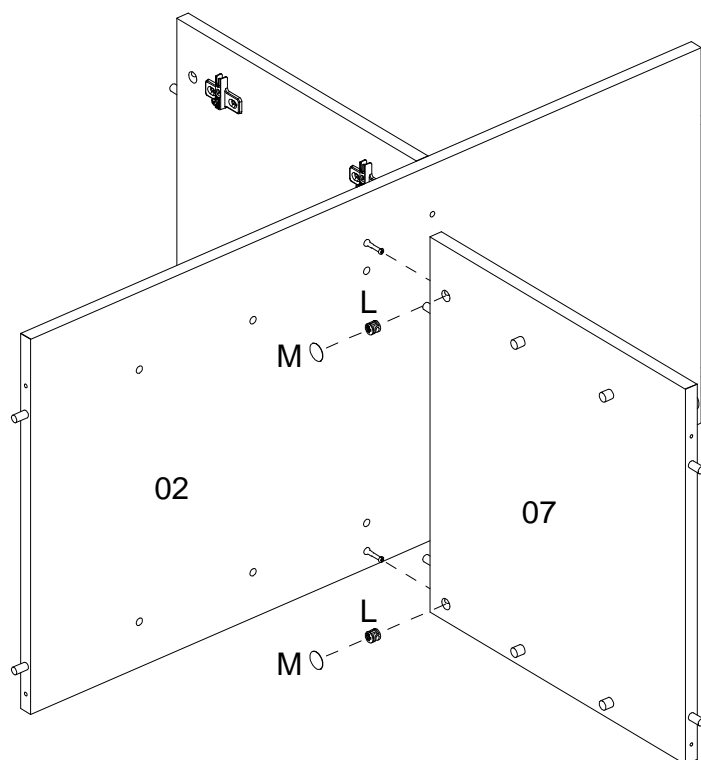
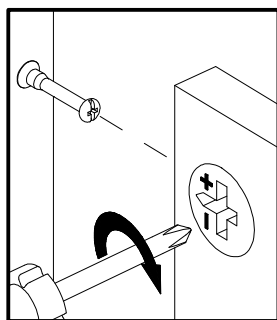

12

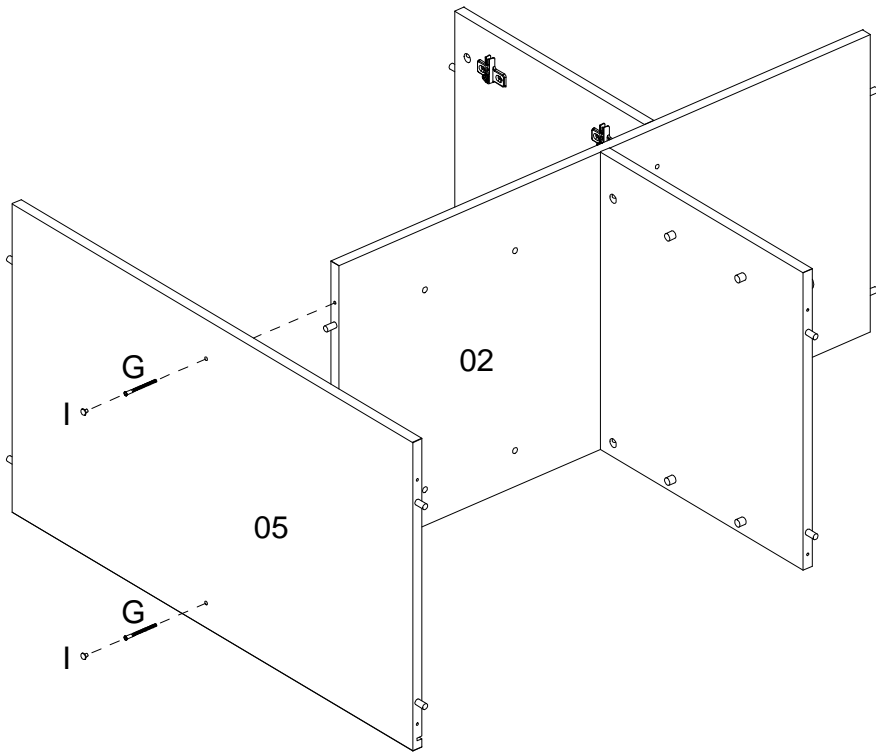
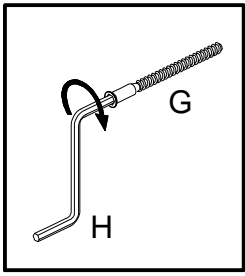

13

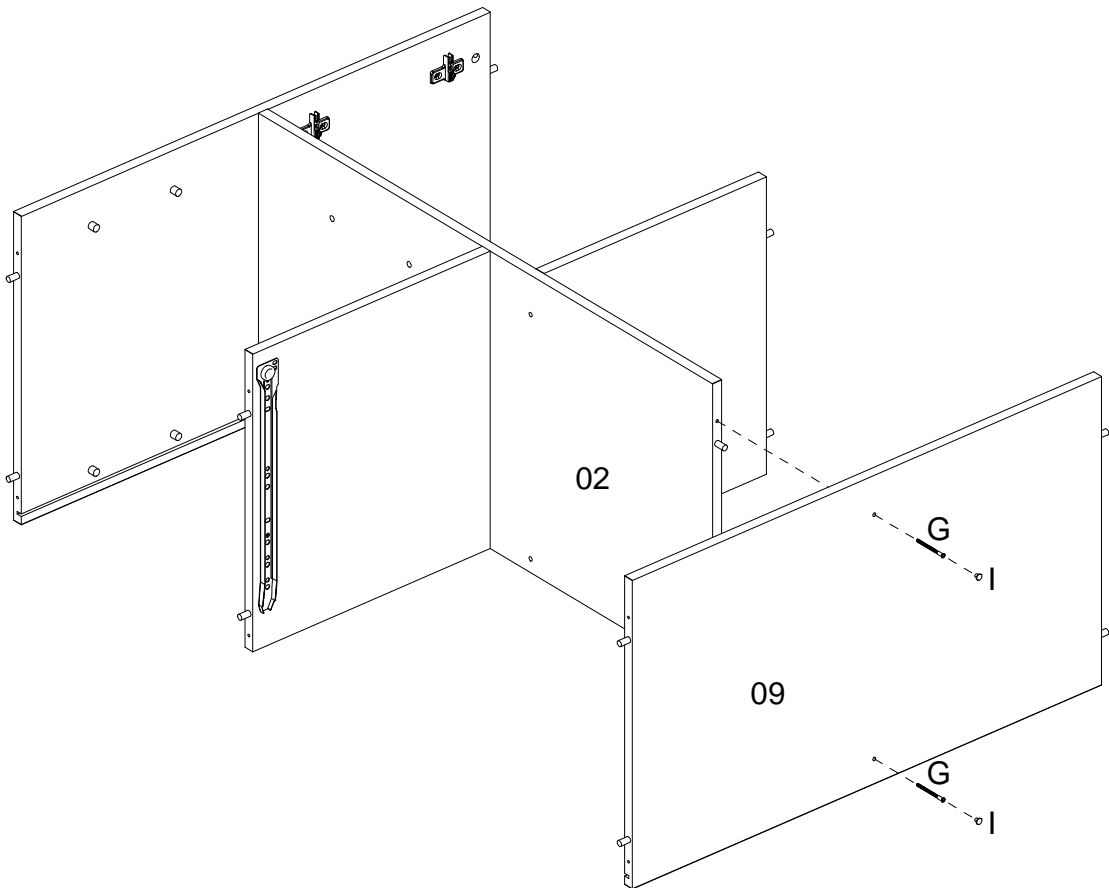



14

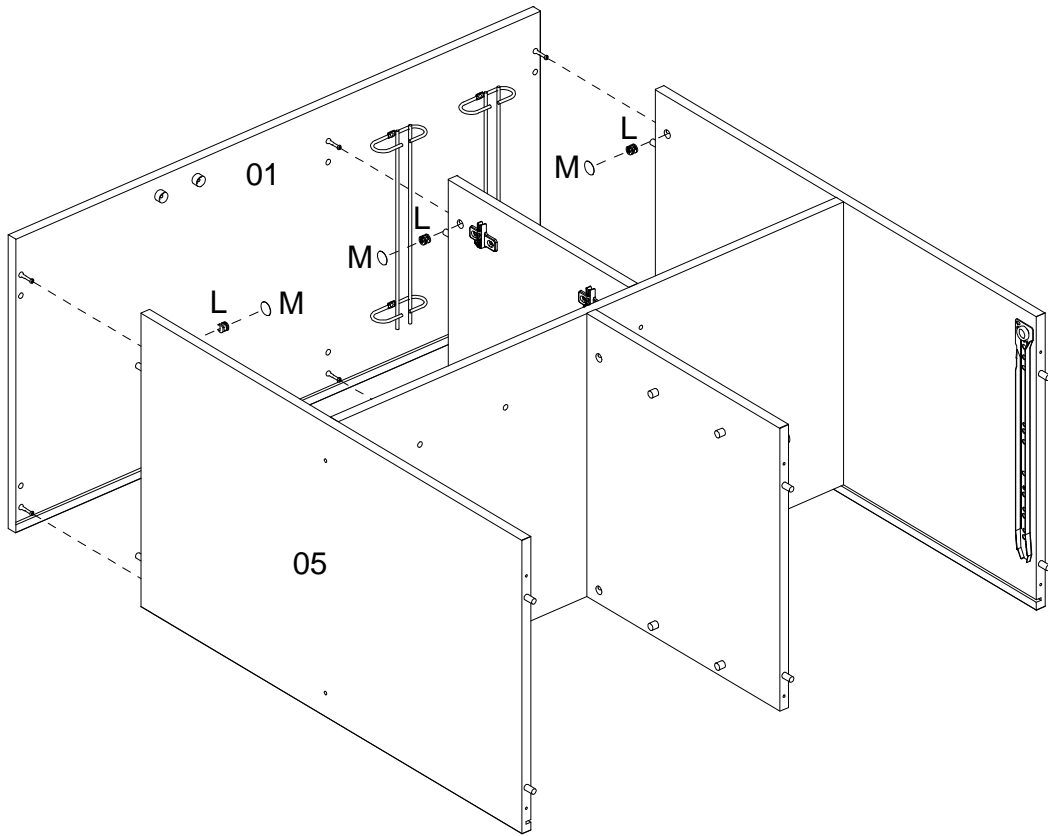

15

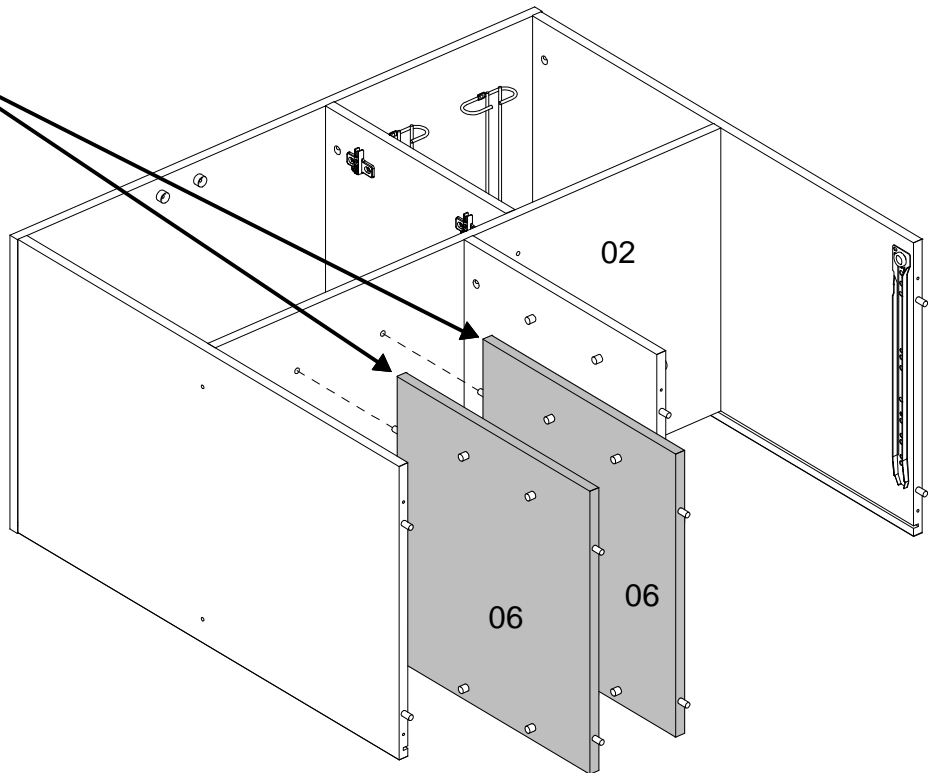
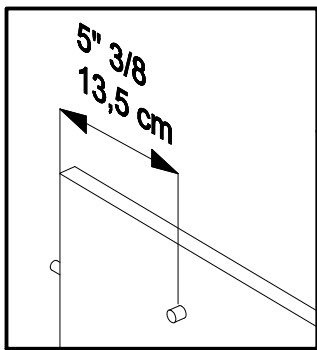

16

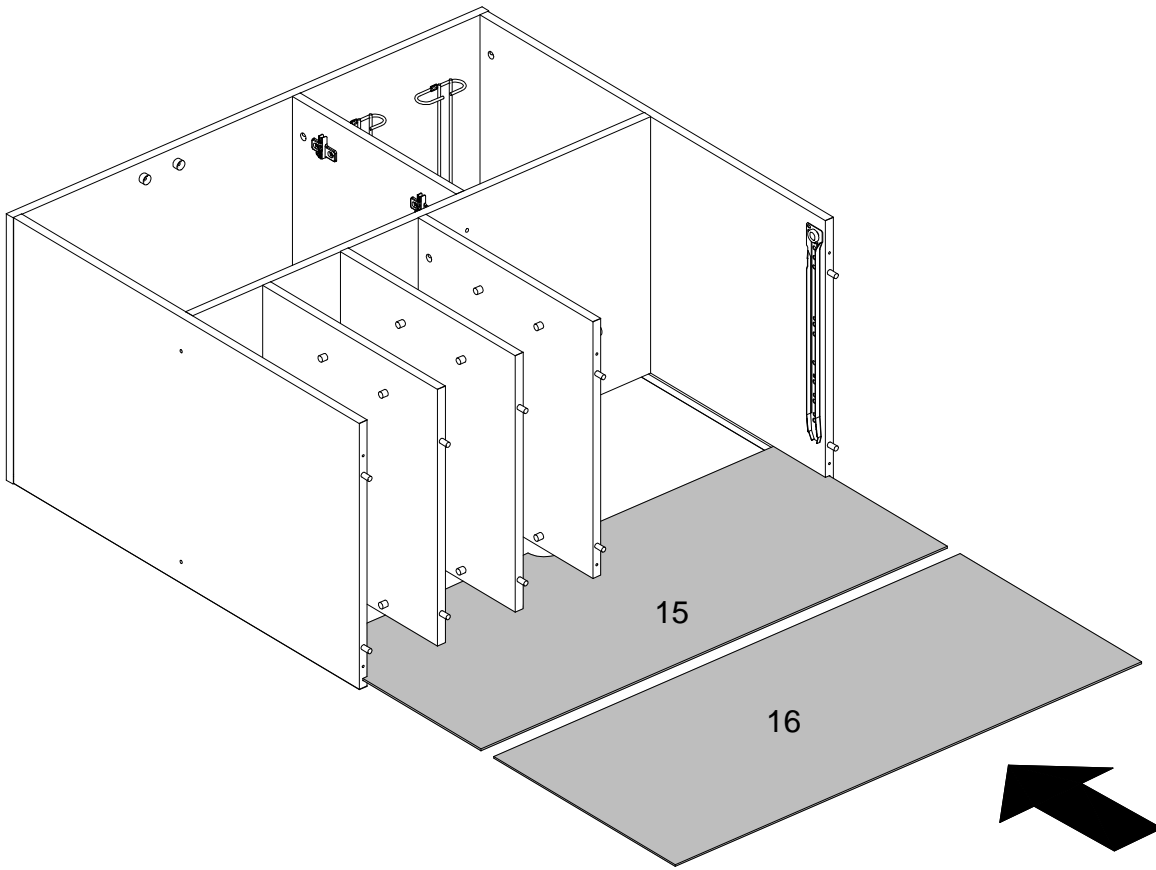

17

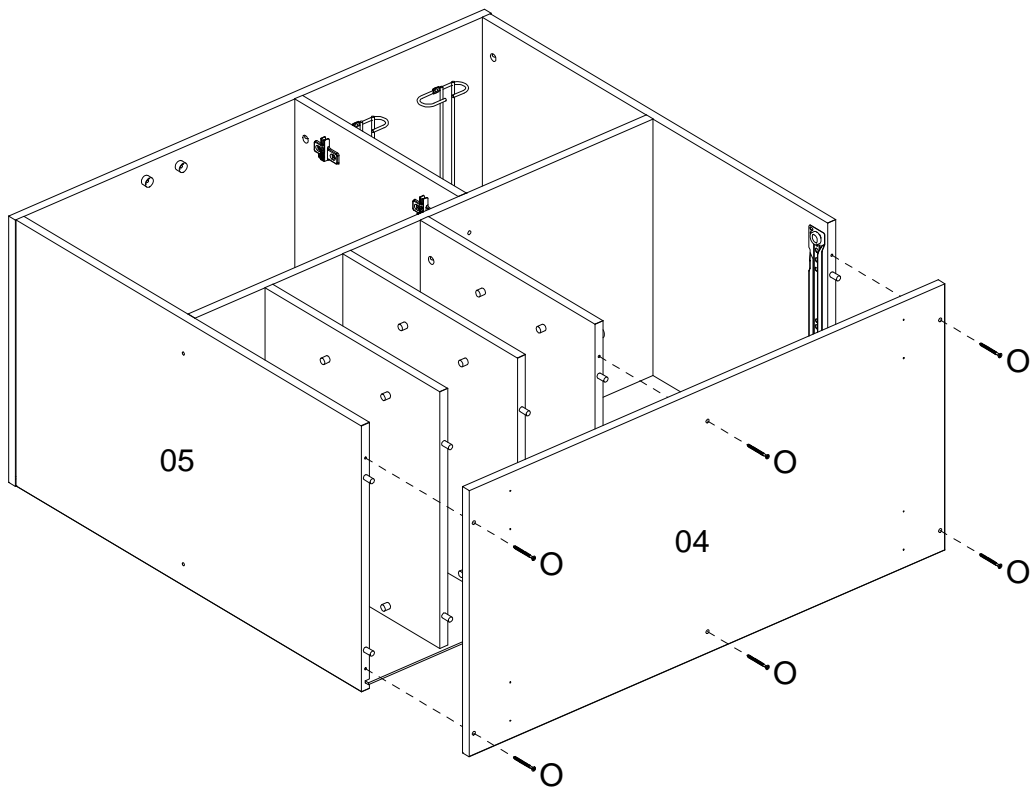

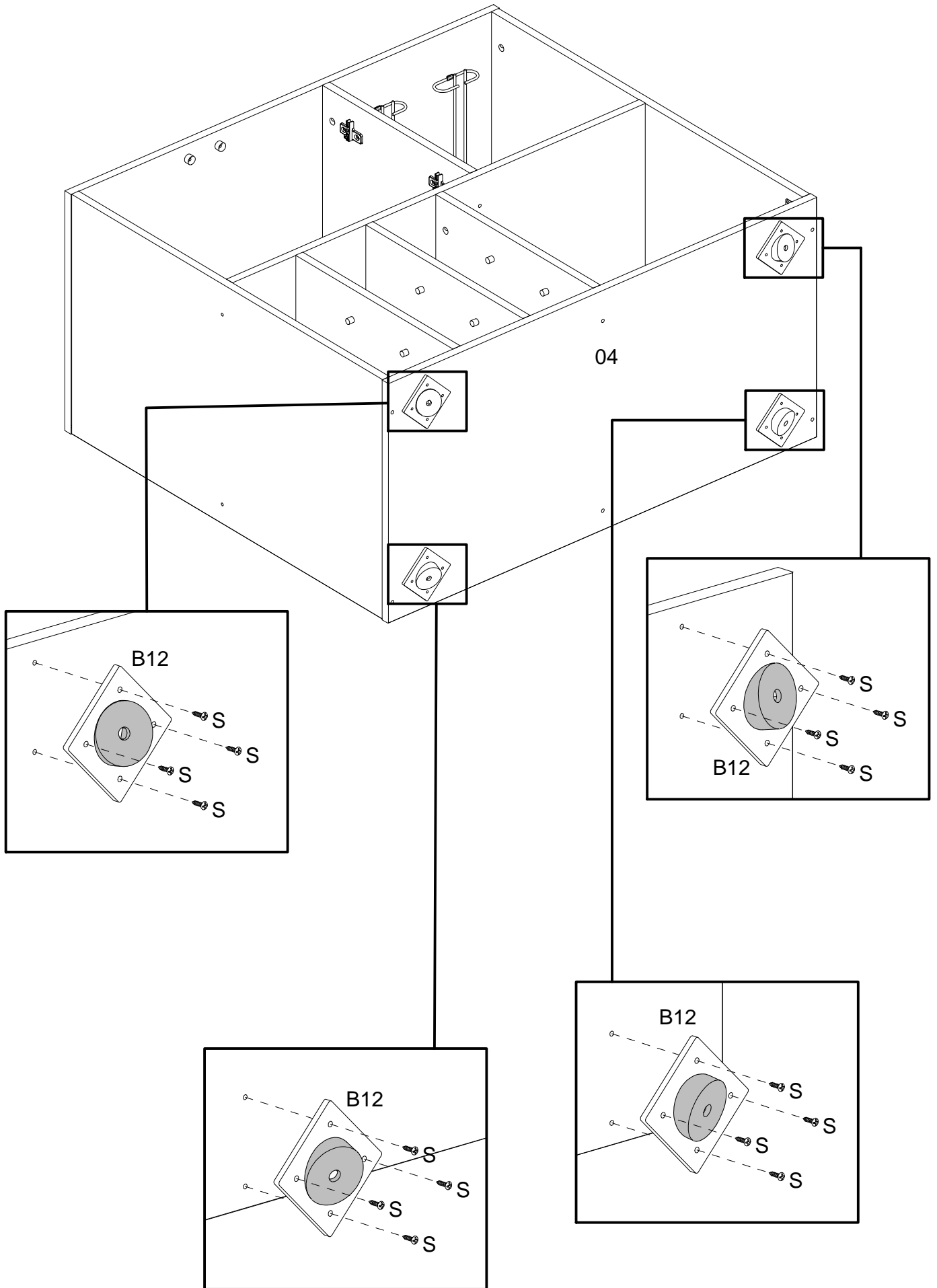

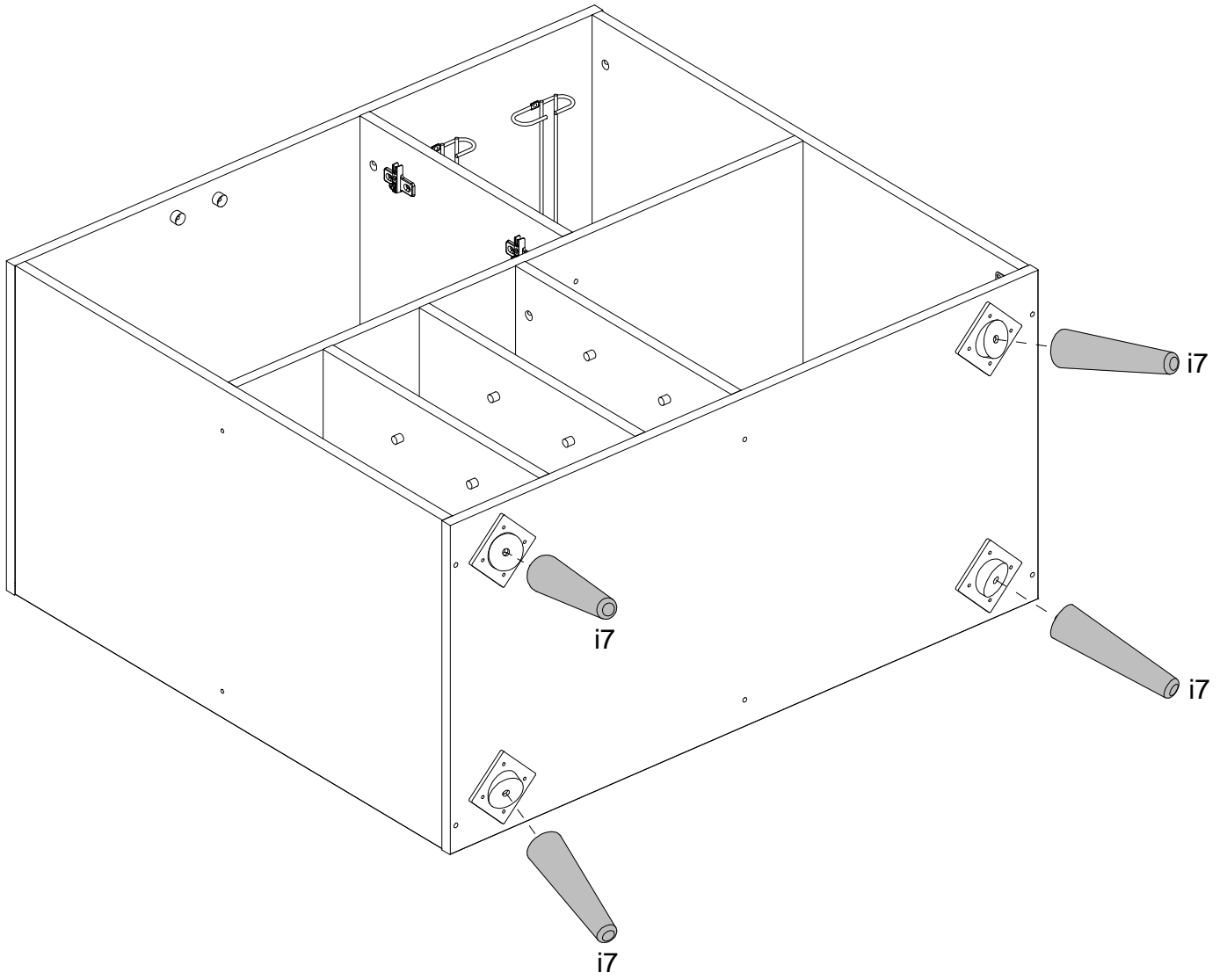

20

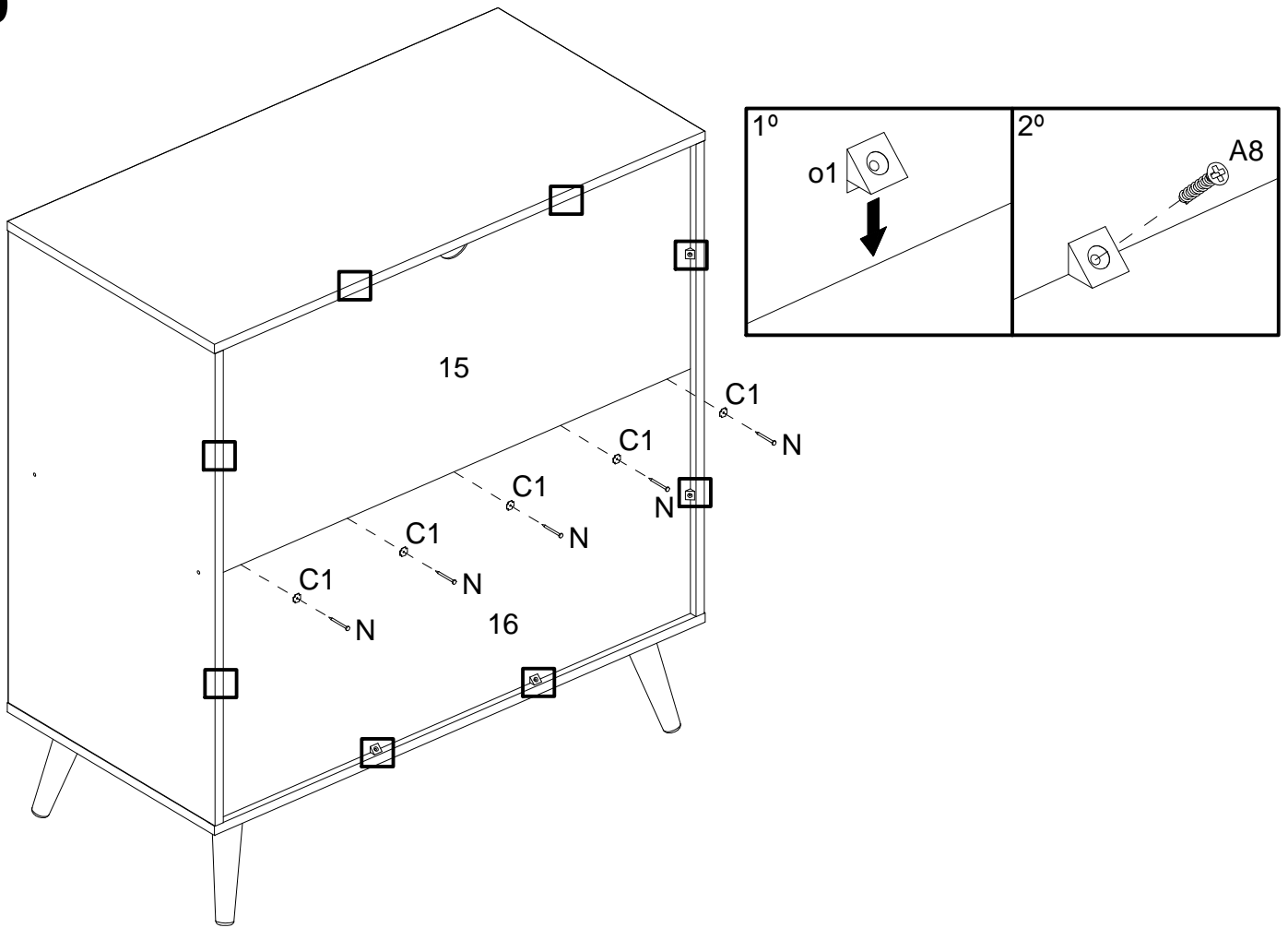

21

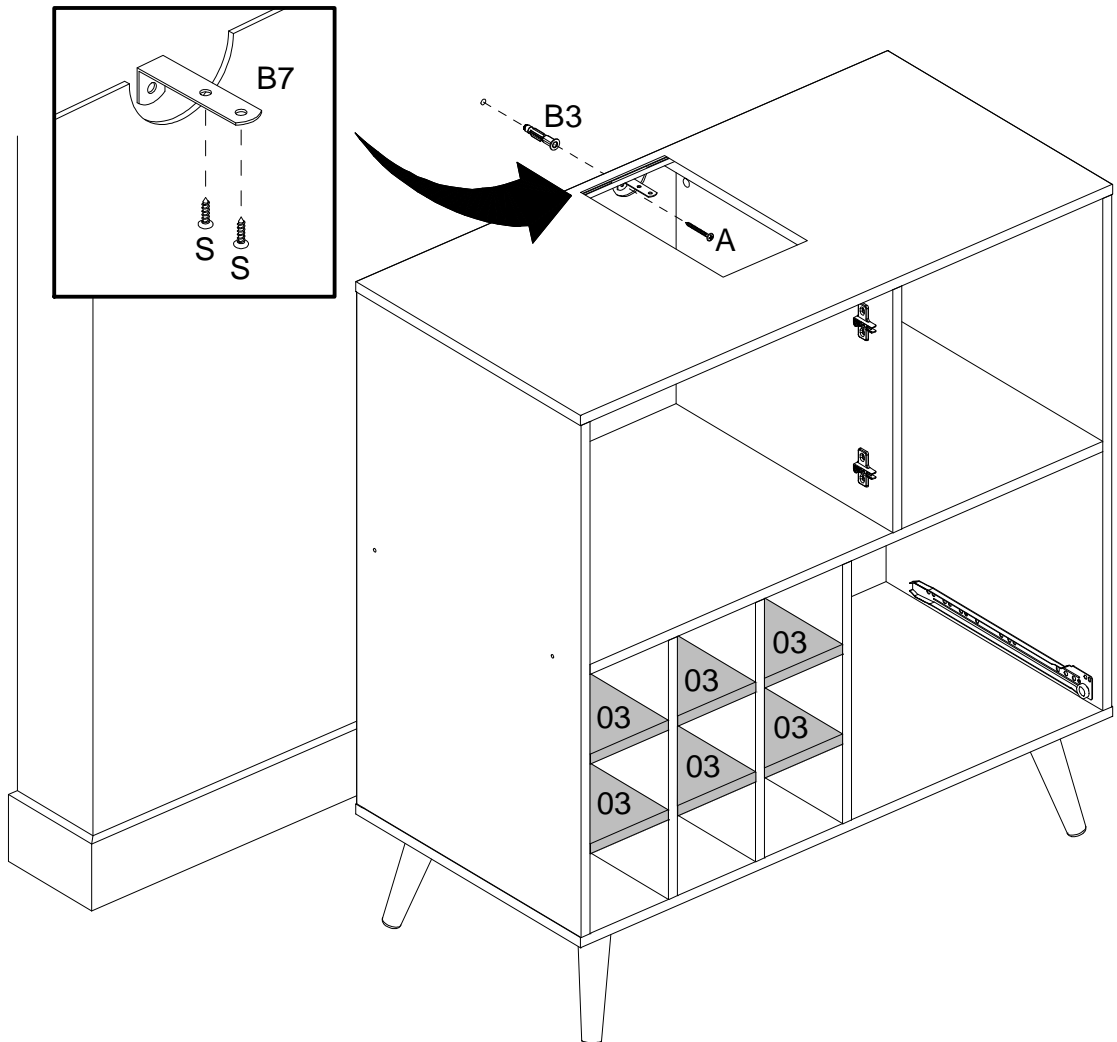

22

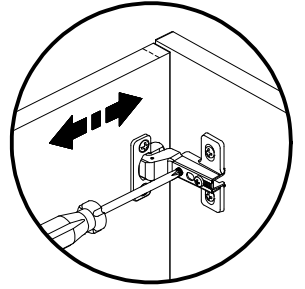
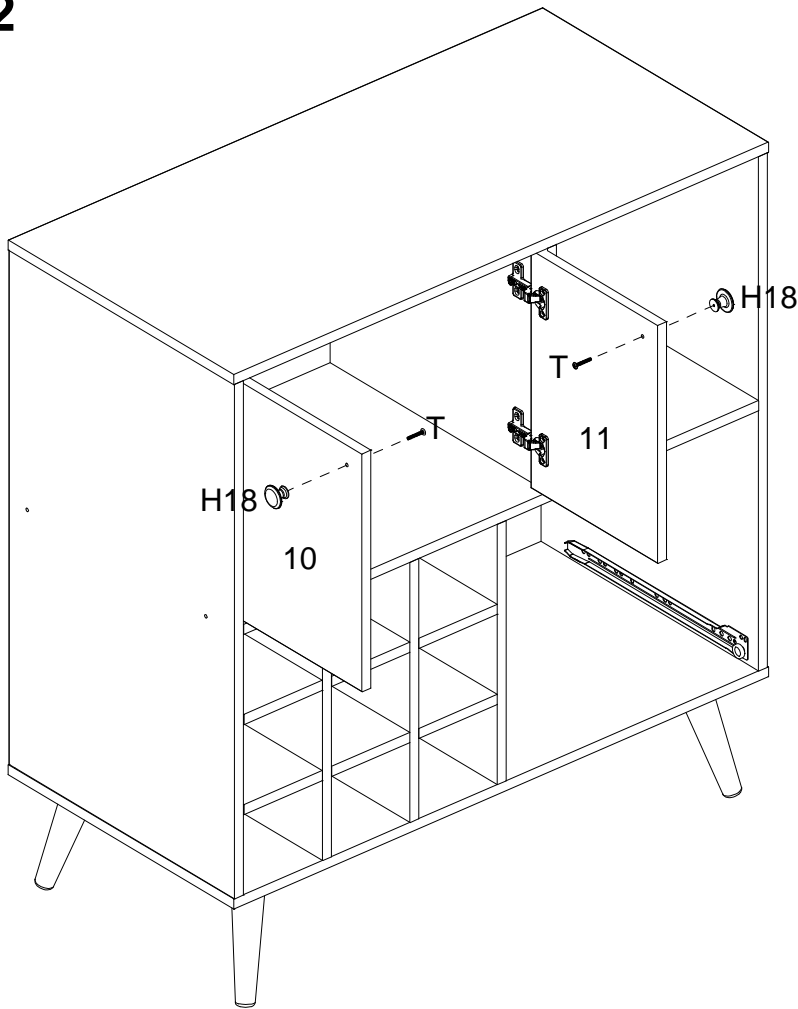

Horizontal Adjustment  
Regulagem Horizontal  
Ajuste Horizontal

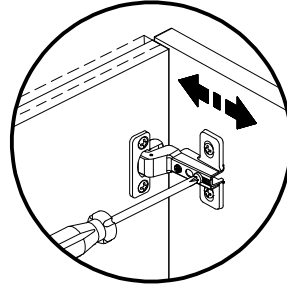

Depth Adjustment  
Regulagem Profundidade  
Ajuste Profundidade

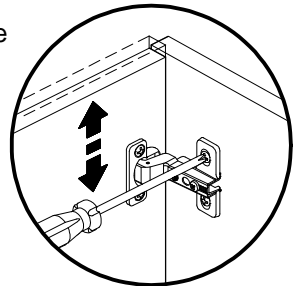

Vertical Adjustment  
Regulagem Vertical  
Ajuste Vertical

23

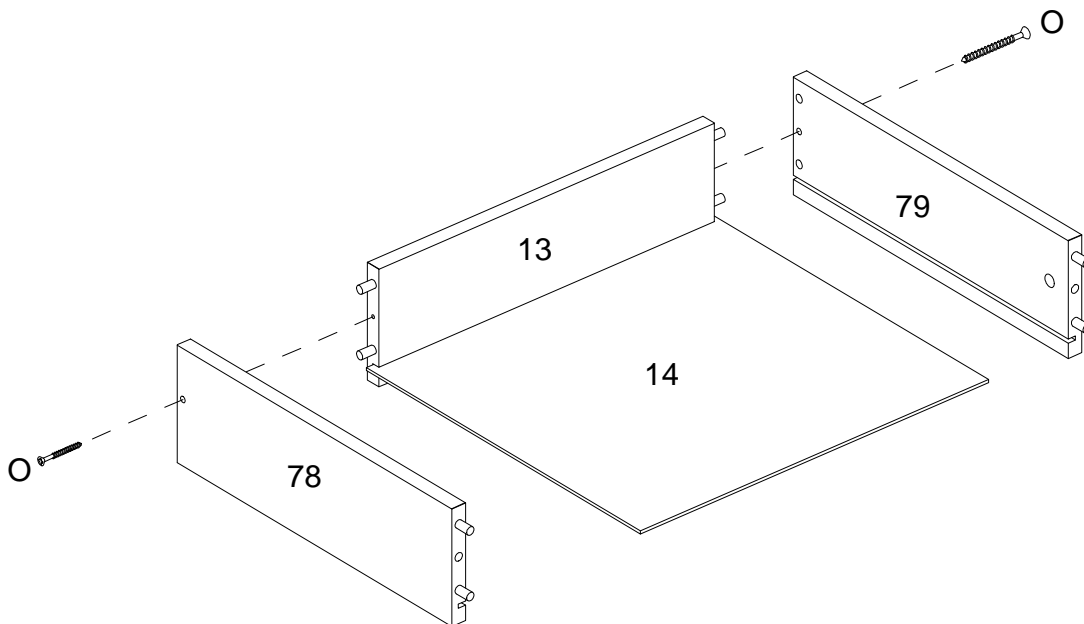

24

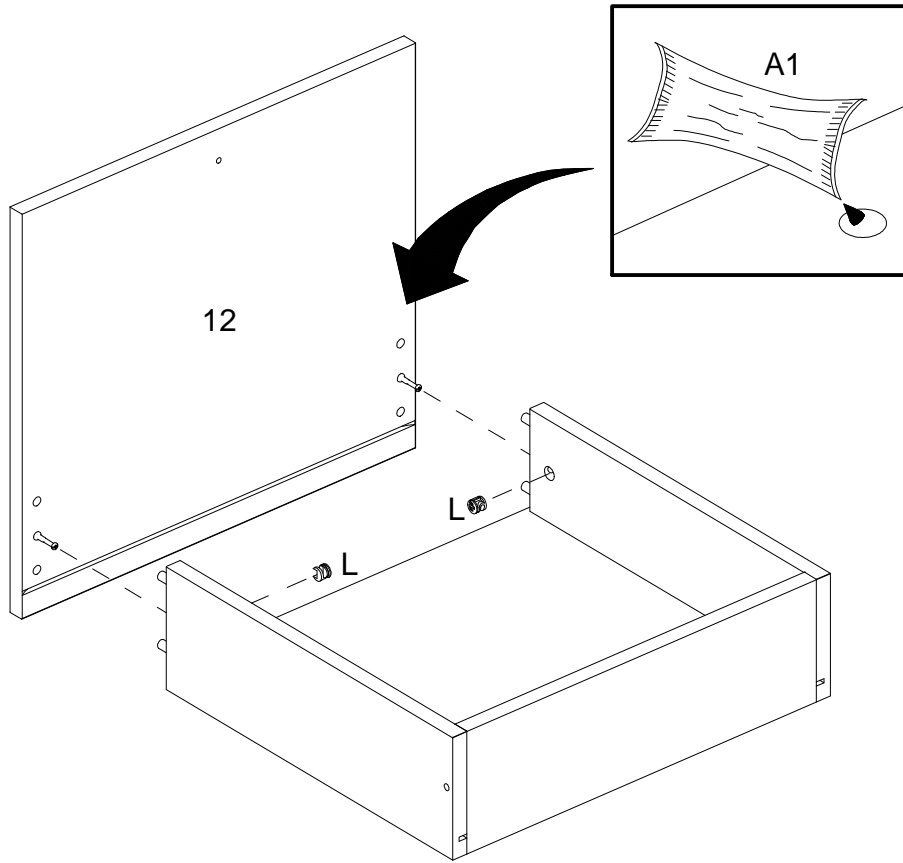

25

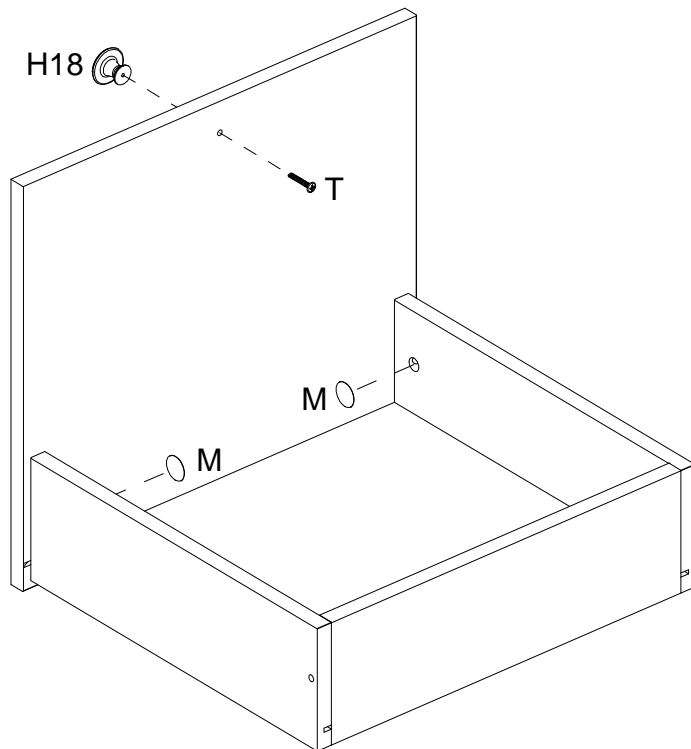

26

THE UNDERSIDE OF THE DRAWER  
LADO INFERIOR DA GAVETA  
PARTE INFERIOR DEL CAJÓN

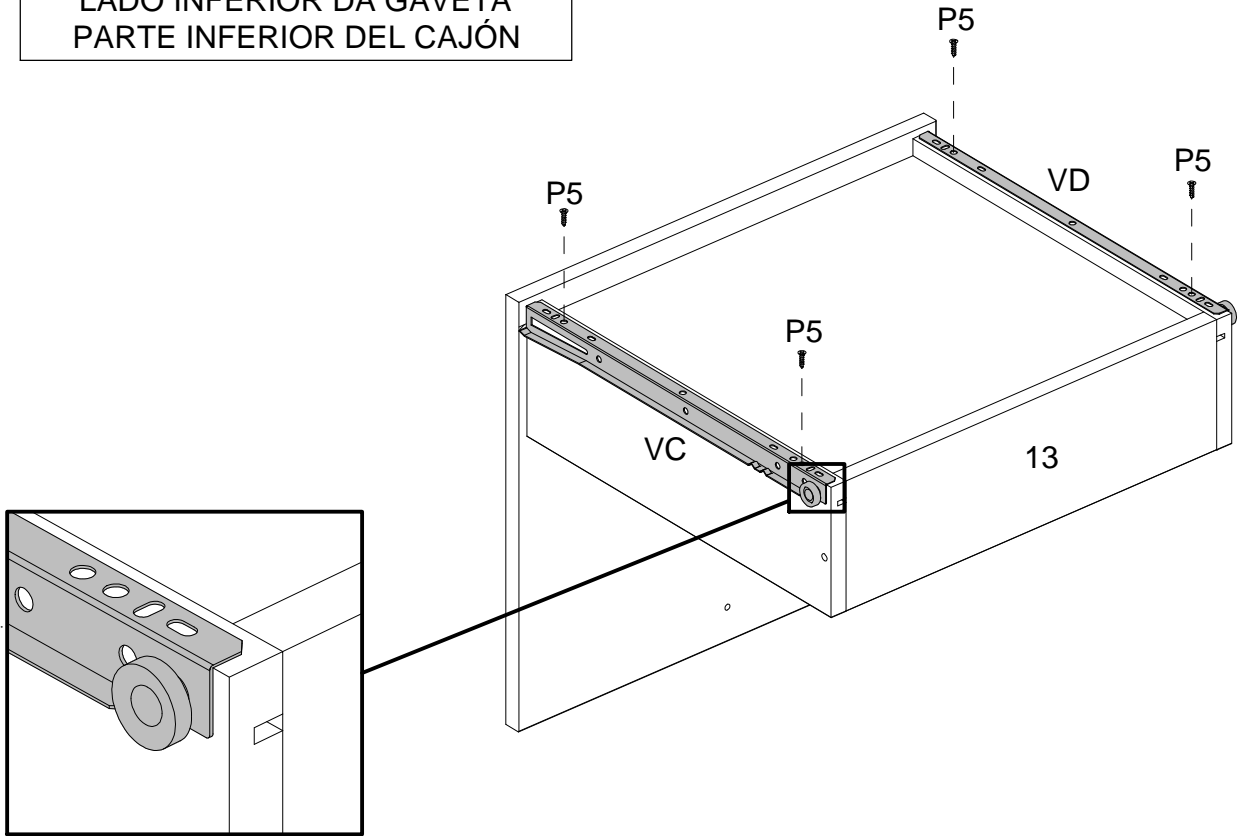

27

