

# CM-8037

## Instruções de Montagem Assembly Instructions Instrucciones de Armado

Acesse Vídeos de Montagens  
Access Mounting Videos  
Acceder a los Vídeos de Montaje  
www.tecnomobili.ind.br

tecnomobili

Estrada RSC 453, Km s/n° | Garibaldi | RS  
CEP: 95720-000 | Fone / Fax: 54.3464.2050  
sac@moveisvideira.com.br

### Notas Especiais:

- 01** -Examine completamente todas as peças do móvel antes de começar o trabalho.  
**02** -Recomenda-se montar o móvel conforme este Manual de Montagem.  
**03** -É de responsabilidade do montador seguir as instruções do Manual de Montagem, que são fundamentais para garantir a estrutura do móvel.  
**04** -Para limpeza, utilizar somente pano úmido e sabão neutro.

### Special notes:

- 01** -Check all parts of the unit thoroughly before starting work.  
**02** -It is recommended to assemble the furniture according to this Installation Manual.  
**03** -It is the responsibility of the assembler to follow the instructions in the Assembly Manual, which are essential to ensure the structure of the furniture.  
**04** -For cleaning use only damp cloth and neutral soap.

### Notas especiales:

- 01** -Examine completamente todas las piezas del mueble antes de iniciar el trabajo.  
**02** -Se recomienda montar el mueble conforme el Manual de Ensamblaje.  
**03** -Es de responsabilidad del montador seguir las instrucciones del Manual de Ensamblaje, que son fundamentales para garantizar la estructura del mueble.  
**04** -Para limpieza solamente usar trapo húmedo y jabón neutro.

### Guarante certificate:

The guarantee of products manufactured by Móveis Videira LTDA covers any defects / manufacturing defects, within the period established by the Consumer Protection Code, in its Article 26, II, which provides for a legal guarantee of ninety (90) days.







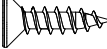
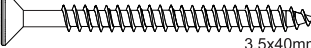
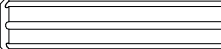
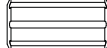
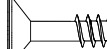
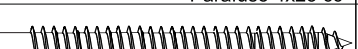

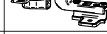

### Lista de Peças / List of pieces / Lista de piezas

CÓD	DESCRIÇÃO	DESCRIPTION	DESCRIPCIÓN	QTD	M. PRIMA	DIMENSÕES	CÓD
01	Divisão Esquerda	Left Division	División Izquierda	1	MDP 15 mm	934x350x15 mm	518037
02	Costa	Back	Costa	2	MDP 15 mm	623x350x15 mm	408037
03	Travessa Pega	Platter Catches	Traviesa Pega	1	MDP 15 mm	623x65x15 mm	638037
04	Divisão Direita	Right Division	División Derecha	1	MDP 15 mm	934x350x15 mm	508037
05	Rodapé	Baseboard	Rodapie	2	MDP 15 mm	1900x65x15 mm	808037
06	Base Traseira	Back Base	Base Trasera	1	MDP 15 mm	1900x467x15 mm	118037
07	Base Frontal	Front Base	Base Frontal	1	MDP 15 mm	1900x467x15 mm	108037
08	Peseira Direita	Right Weight	Pesera Derecha	1	MDP 15 mm	525x92x15 mm	338037
09	Peseira Esquerda	Left Weight	Pesera Derecha	1	MDP 15 mm	525x92x15 mm	348037
10	Travessa Inferior Peseira	Headrest Botton Traverse	Traviesa Inferior Pesera	1	MDP 15 mm	756x80x15 mm	628037
11	Cabeceira	Headboard	Cabecera	1	MDP 15 mm	810x120x15 mm	708037
12	Travessa Ripado	Traverse	Traverse	6	MDP 15 mm	160x65x15 mm	608006
13	Cabeceira Intermediaria	Interdiate Headboard	Cabecera Intermediaria	1	MDP 15 mm	810x389x15 mm	718037
14	Cabeceira Inferior	Lower Headboard	Cabecera Inferior	1	MDP 15 mm	810x389x15 mm	728037
15	Pé Cabeceira Direito	Right Foot Headboard	Pie Derecho Cabecera	1	MDP 15 mm	1060x65x15 mm	318037
16	Pé Cabeceira Esquerdo	Left Foot Headboard	Pie Izquierdo Cabecera	1	MDP 15 mm	1060x65x15 mm	328037
17	Travessa Cabeceira	Headboard Traverse	Traviesa Cabecera	1	MDP 15 mm	942x45x15 mm	618037
18	Travessa Superior Peseira	Headrest Upper Traverse	Traviesa Superior Pesera	1	MDP 15 mm	904x92x15 mm	608037
19	Lateral	Side	Lateral	2	MDP 15 mm	1900x92x15 mm	308037
20	Suporte Para Lastro	Ballast Suport	Soporte Lastre	4	MDP 22 mm	900x42x22 mm	9697
21	Lastro	Ballast	Lastre	12	MDP 10 mm	900x70x10 mm	9543
22	Porta	Door	Puerta	1	MDP 15 mm	616x325x15 mm	88037

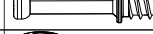
### TAMANHO REAL - TAMAÑO VERDADERO - REAL SIZE

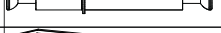
REF	DESCRIÇÃO	QTD	CÓD
A	 3,5x14mm CC	44	3639
B	 3,5x40mm CC	08	8115
C	 Cavilha 8 x 30mm	58	2806
D	 Cavilha 8 x 20mm	02	6521
E	 Parafuso 4x25 cc	04	9511
F	 4,0 x 50mm CC	16	9779

### LUSTRACÃO - ILUSTRACION - ILLUSTRATION

REF	DESCRIÇÃO	QTD	CÓD
G	 22x3mm Prego 10x10	38	3051
H	 22x17x12mm	03	3572
I	 14 x 4mm Sapata Deslizadora	14	8112
J	 Dobradiça Alta 26mm Calço N° 12	02	6517
K	 32mm Chapa Metálica 42x14x1,2mm	02	8889
L	 9 x 12mm Porca Cilíndrica	08	9449
M	 34x7mm Parafuso minifix	14	3771
N	 15x12mm Tambor minifix	34	9516
O	 Adesivo Tapa Furo	20	
P	 62 x 7mm Minifix Haste Dupla	10	8991
Q	 25,6 x 40mm Suporte para Lastro	08	
R	 Parafuso 3,5 x 14 CF	14	3639
S	 12 x 12 x 12mm Cantoneira 2 Furos	14	3615
T	 Articulador	01	9710



### Ferramentas | Tools | Herramientas

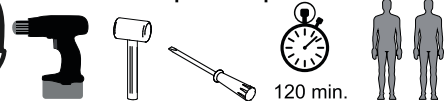

120 min.

Revisão:01

Data:20/11/2023

Use the ruler below to measure the components

Measured in mm

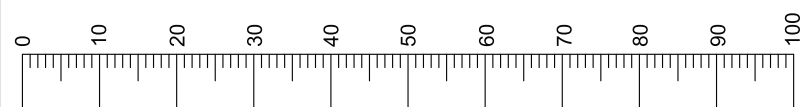

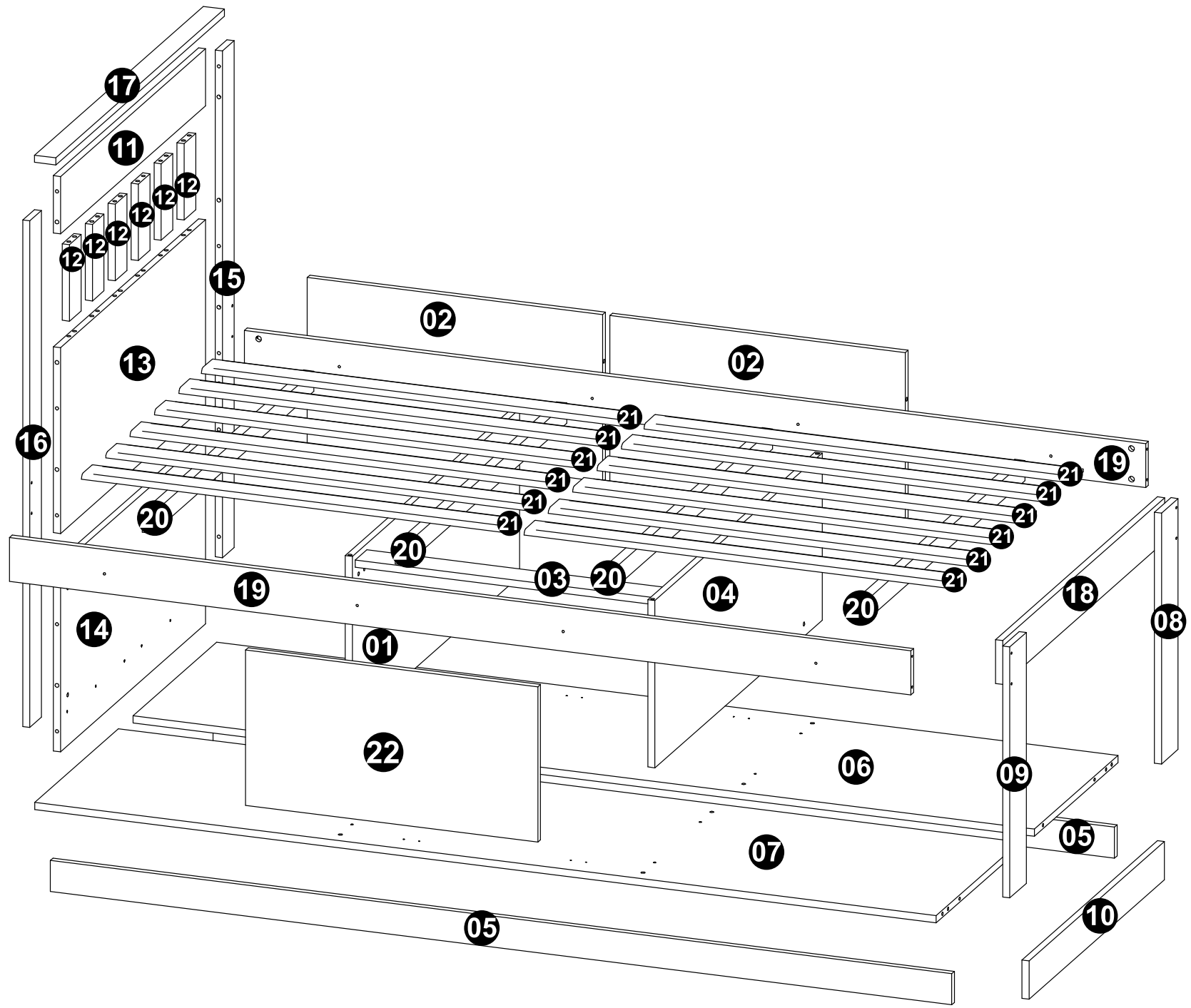



2

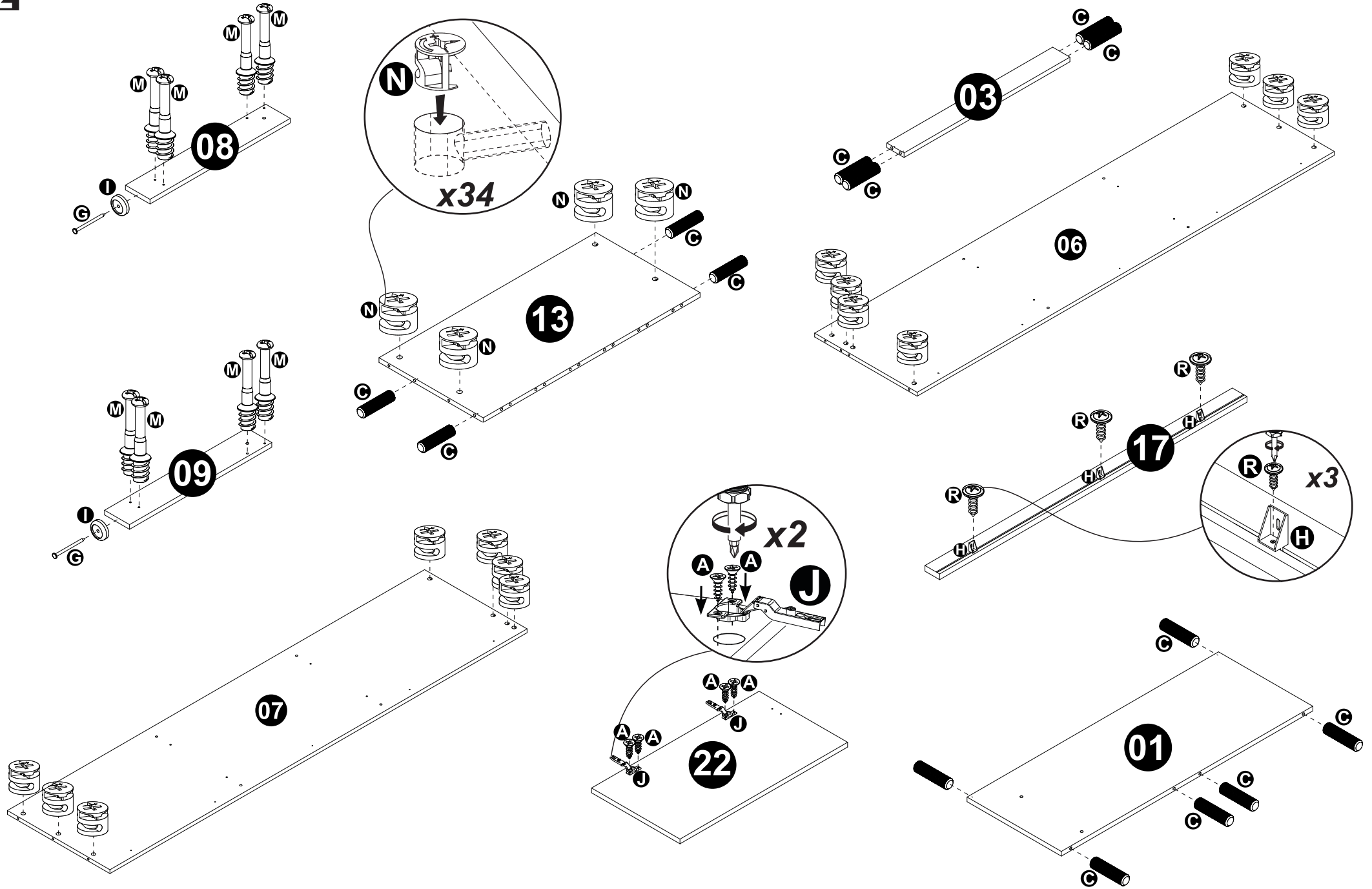



3

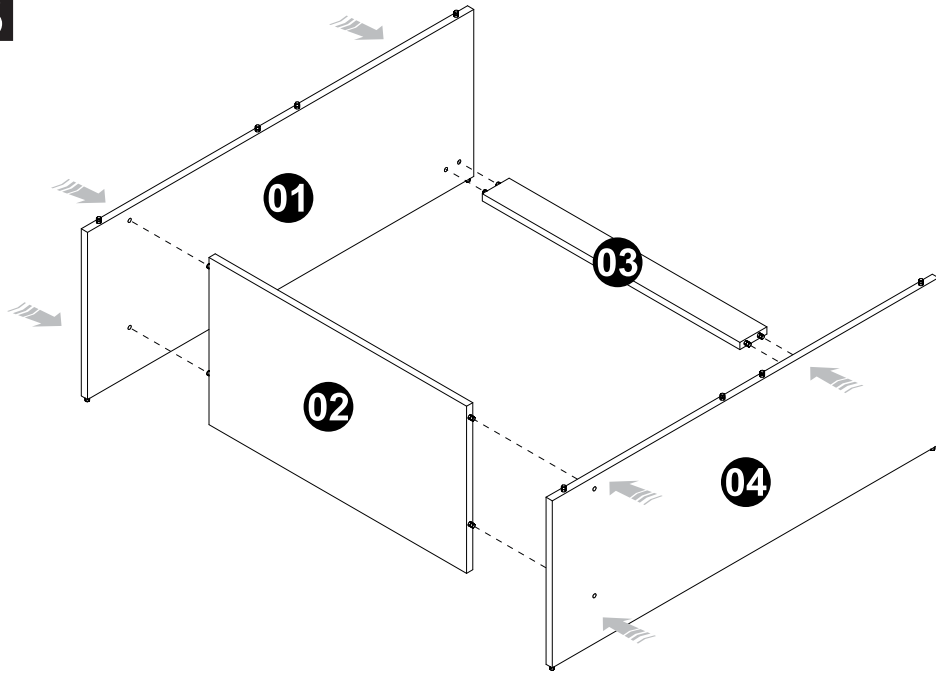

4

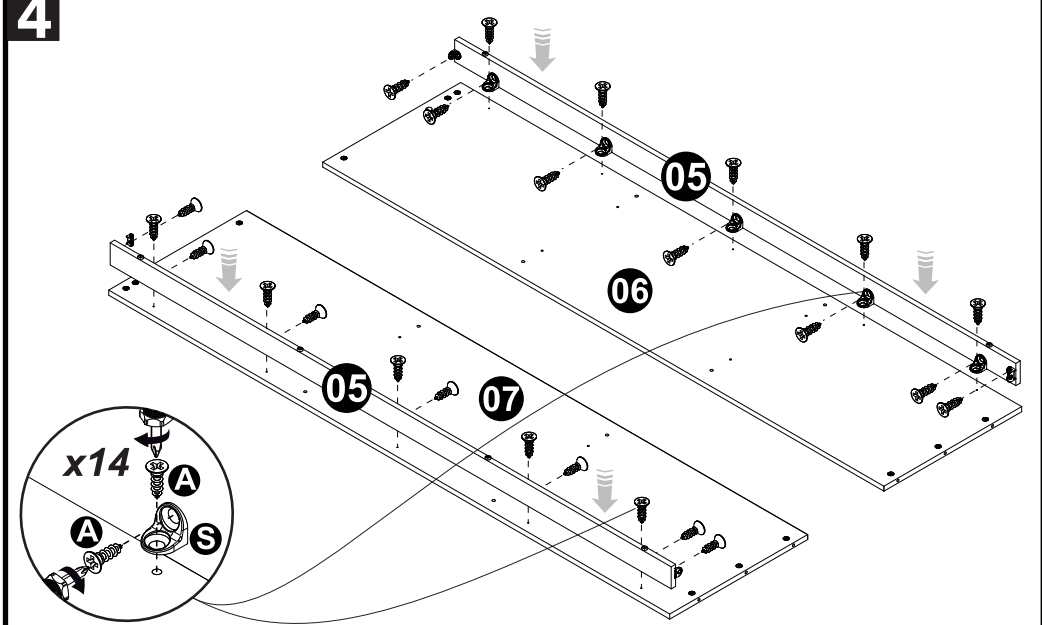

5

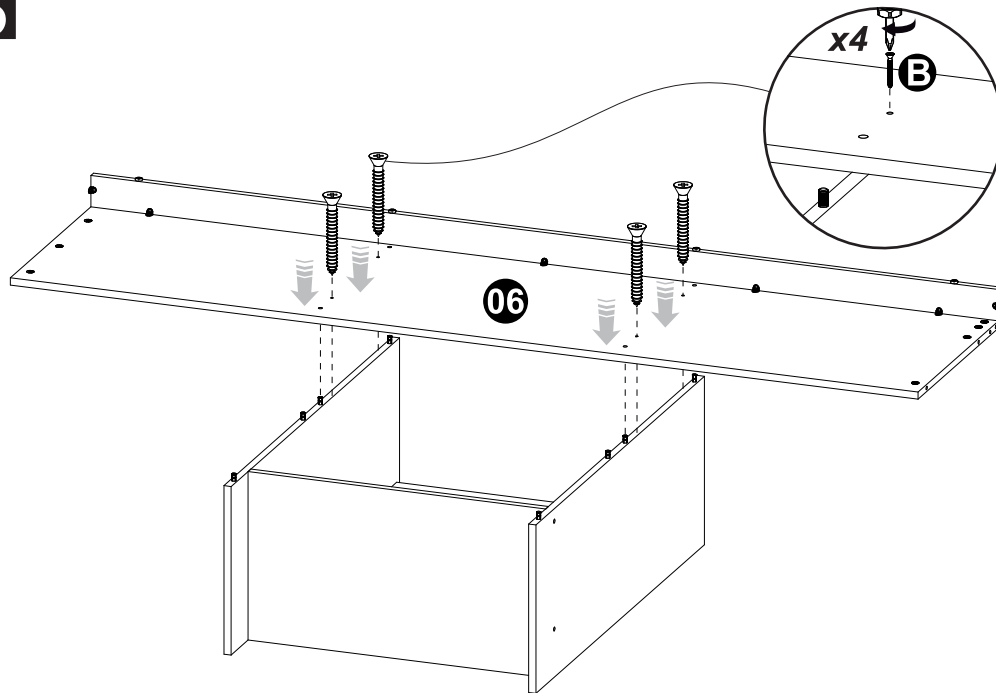

6

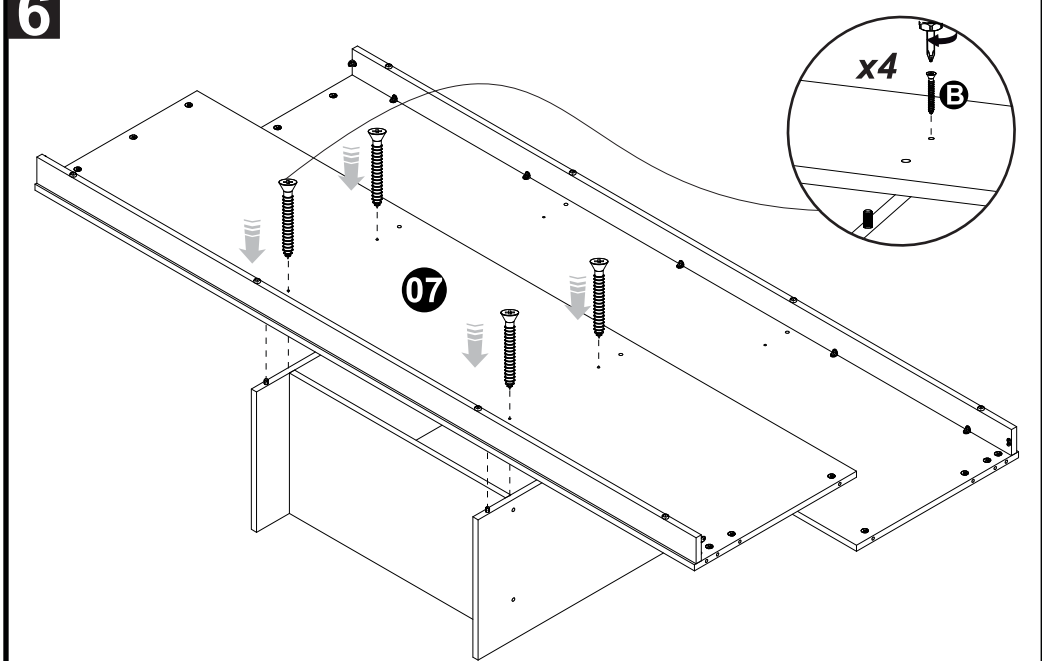

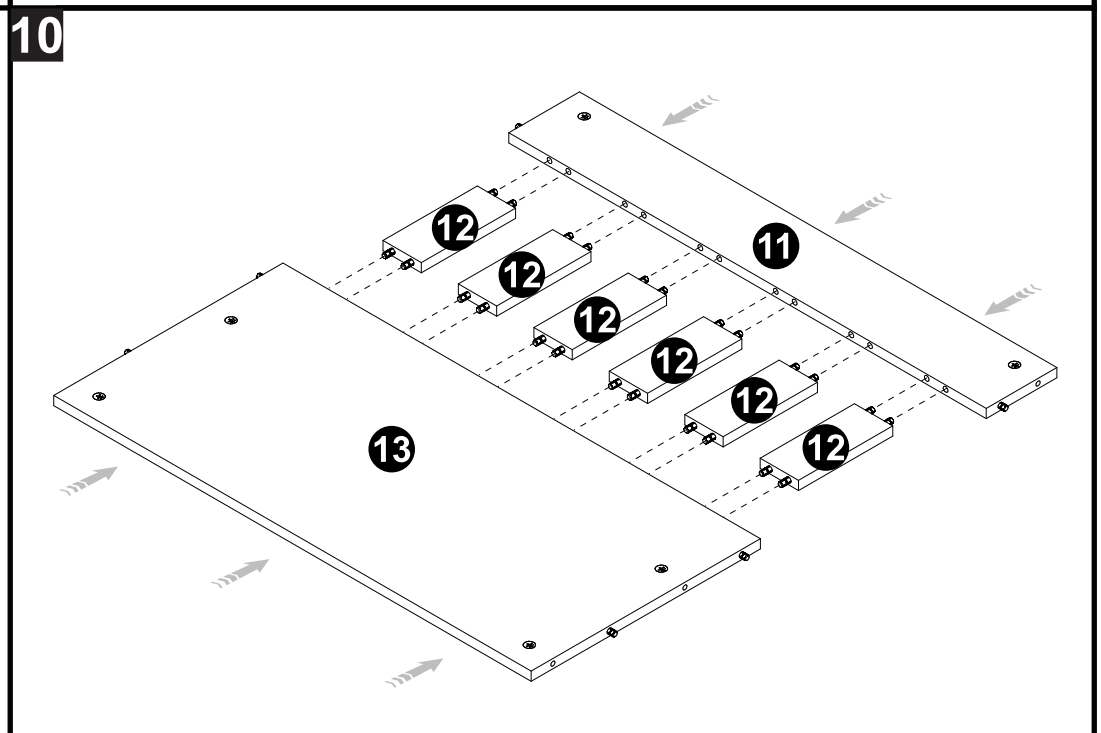
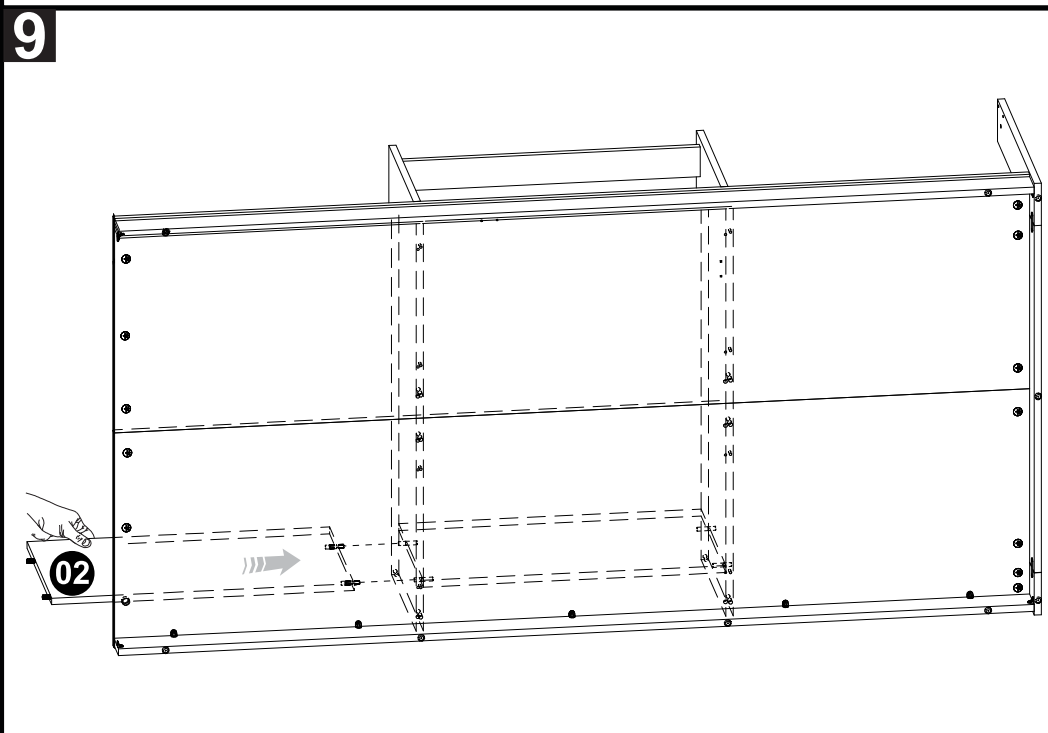
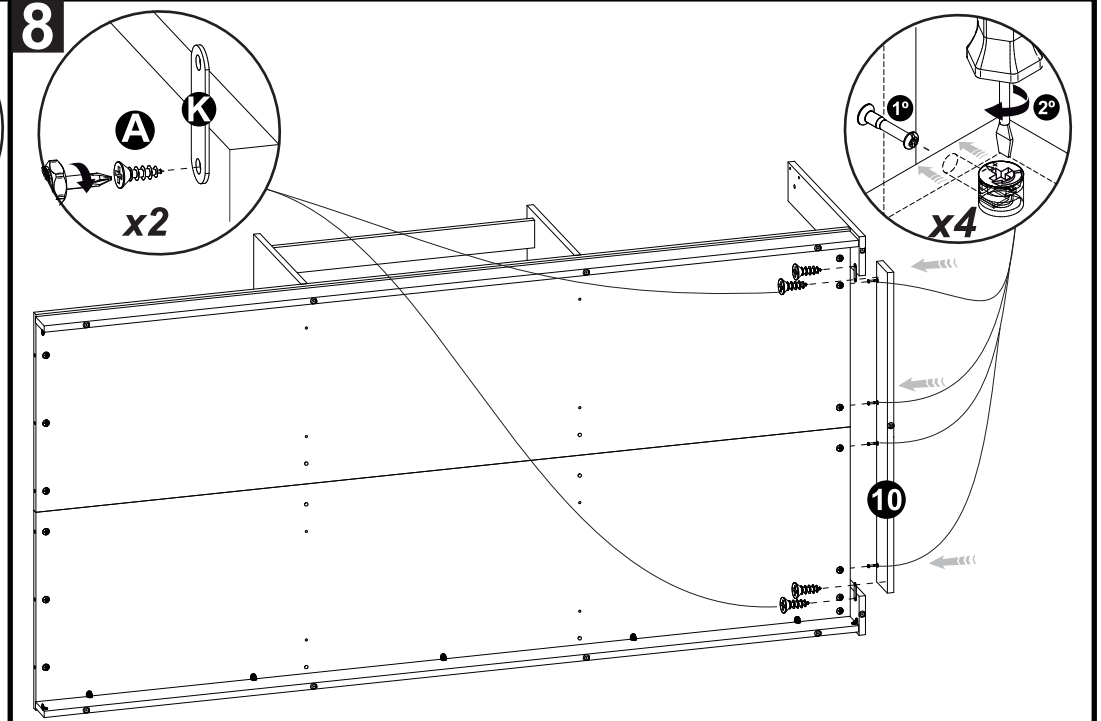
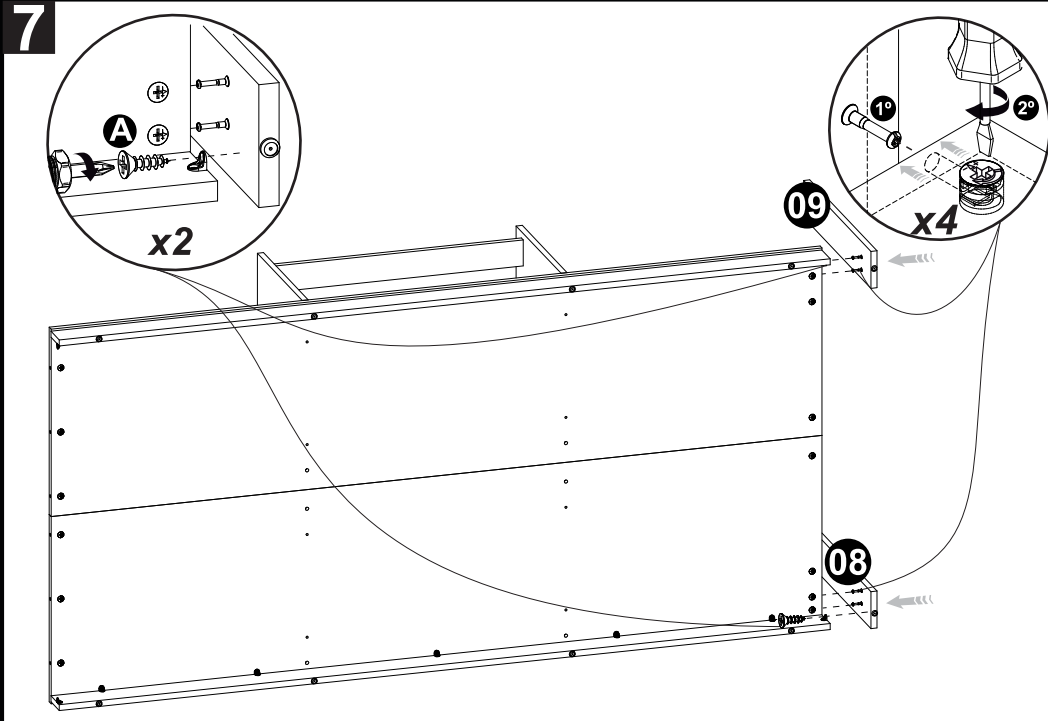

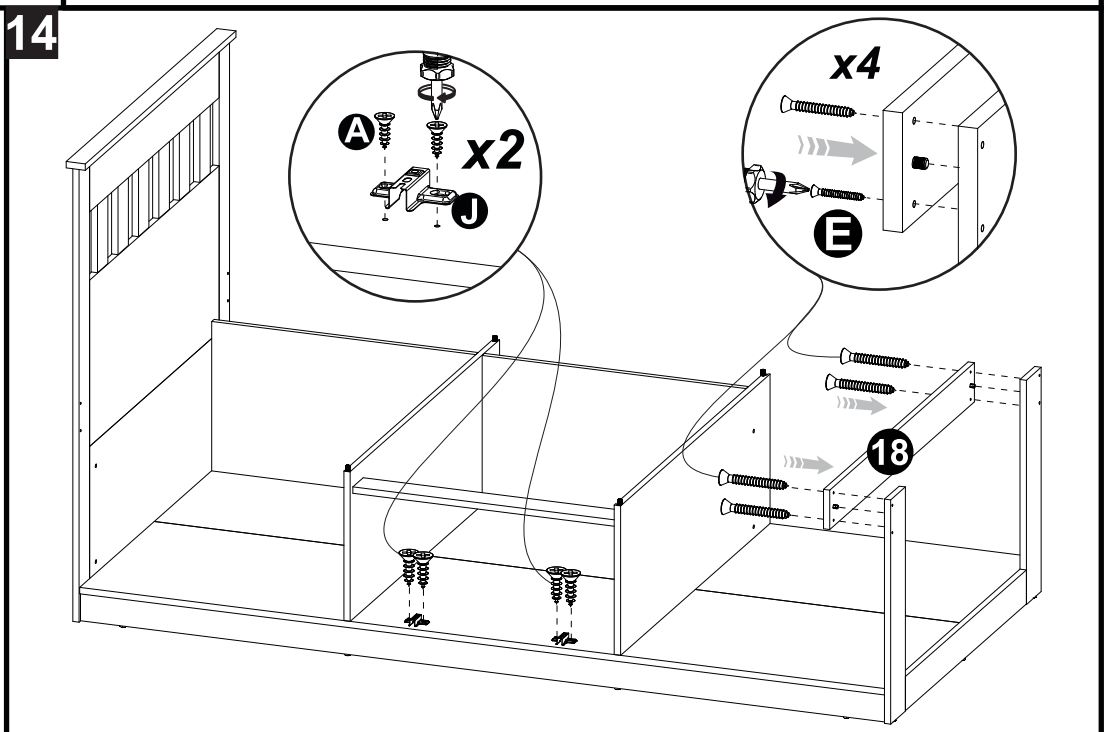
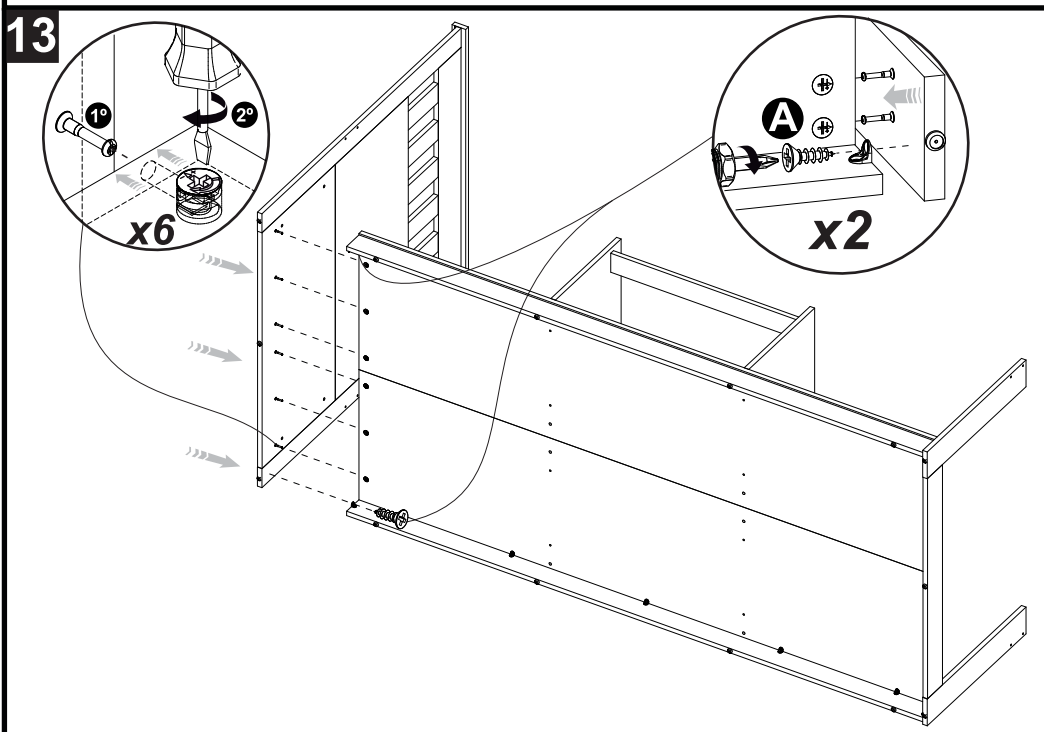
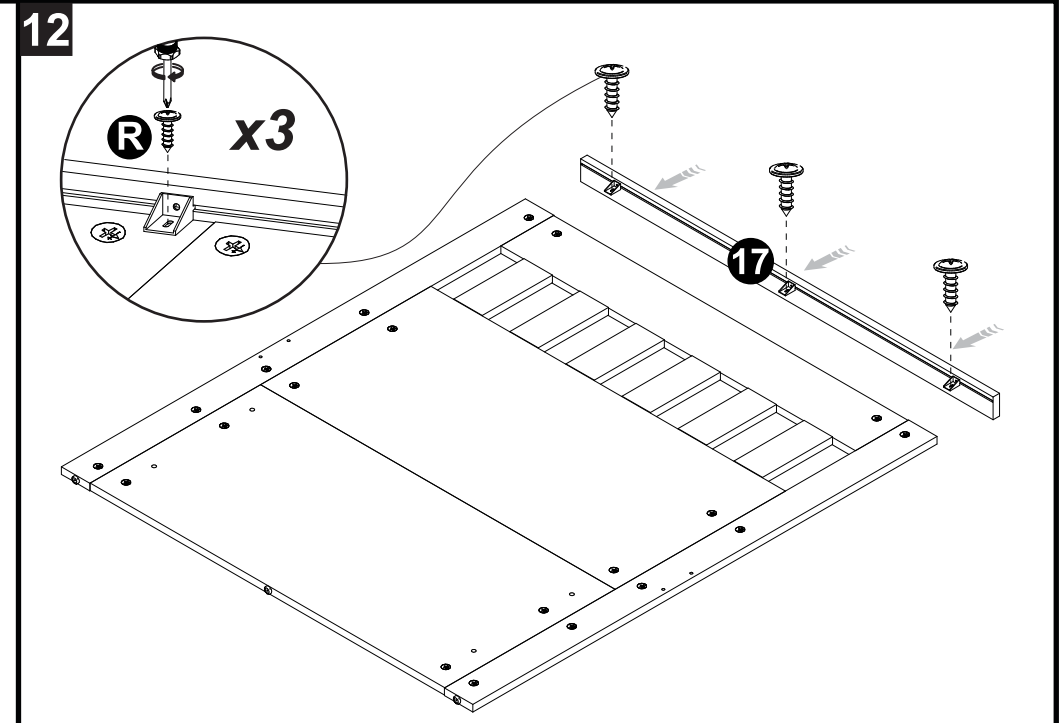
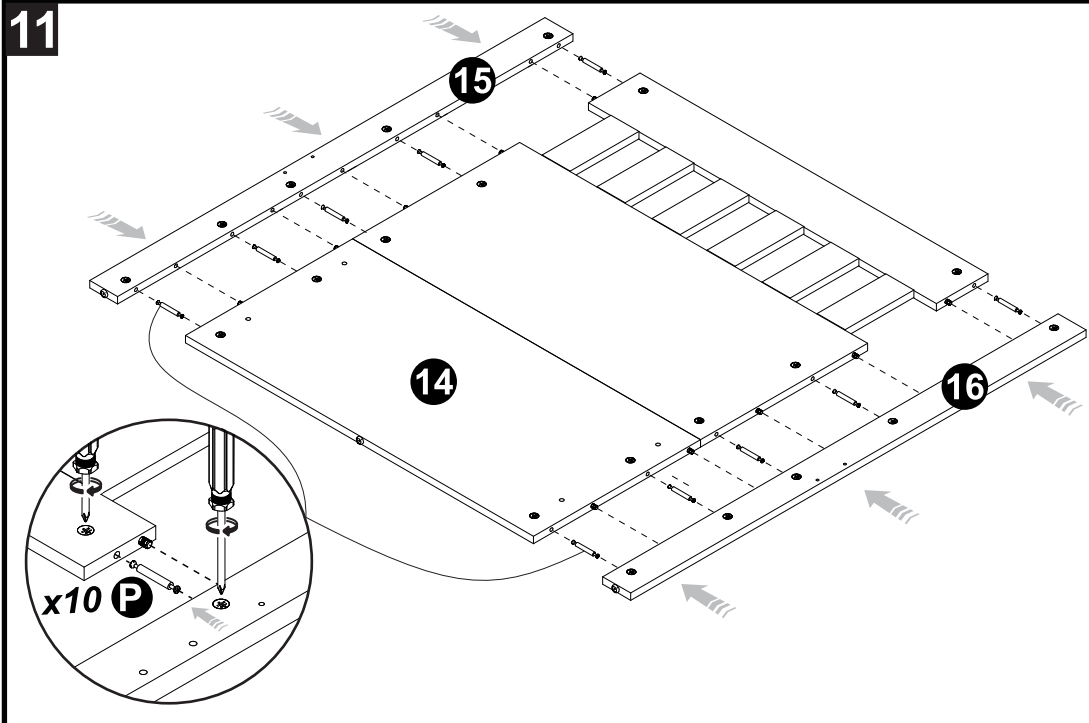

15

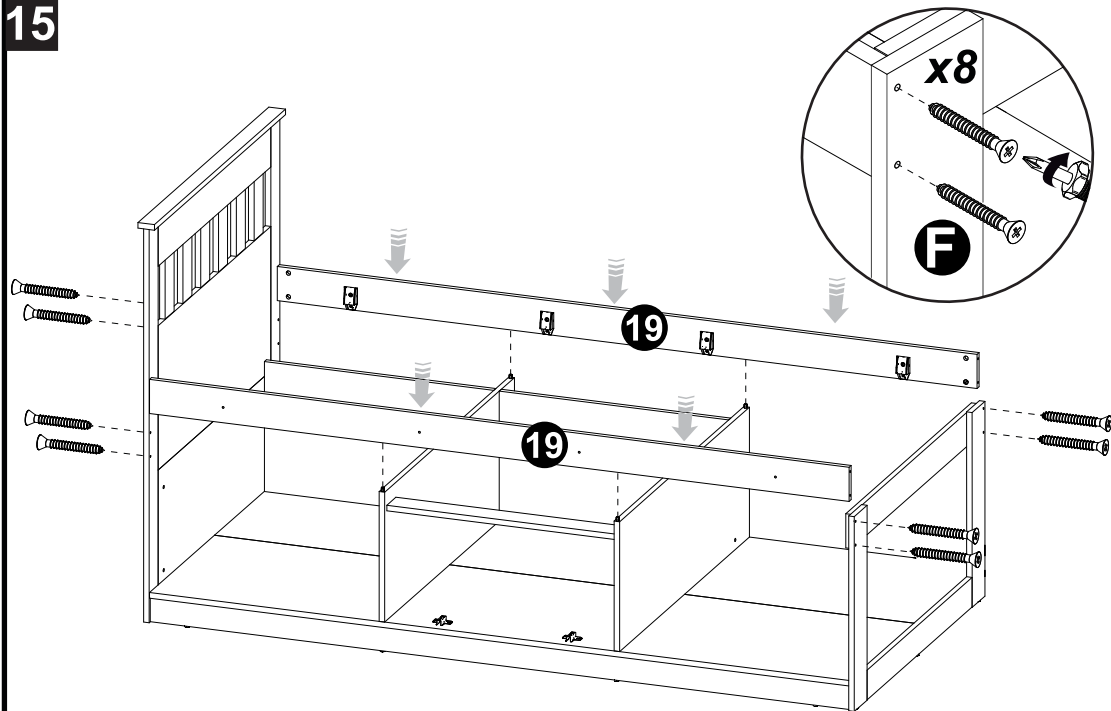

16

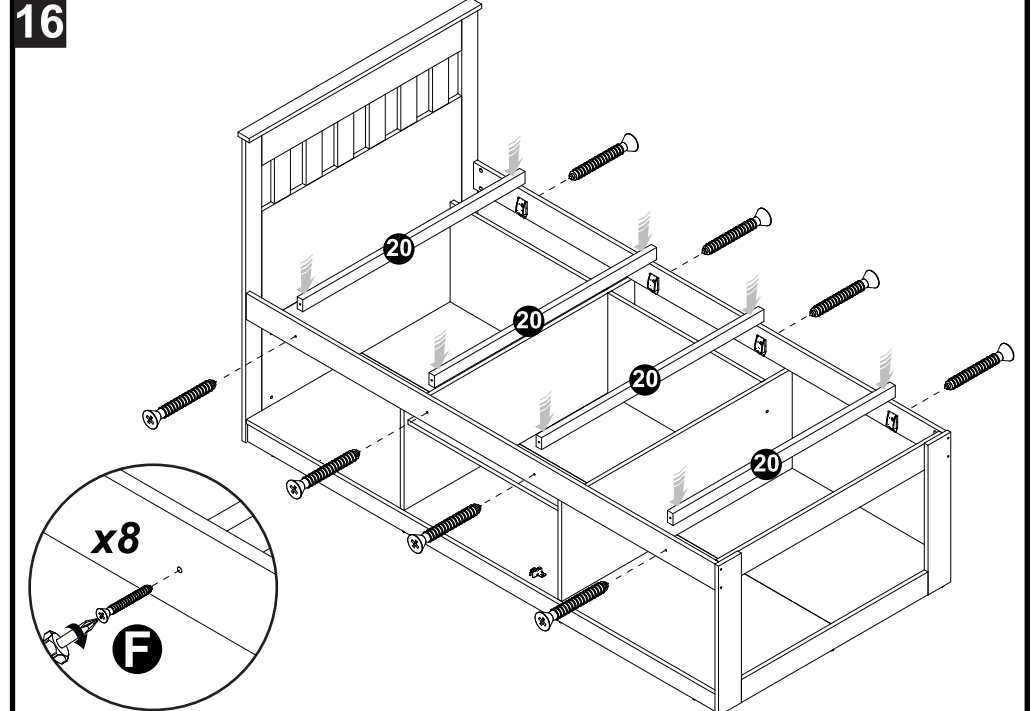

17

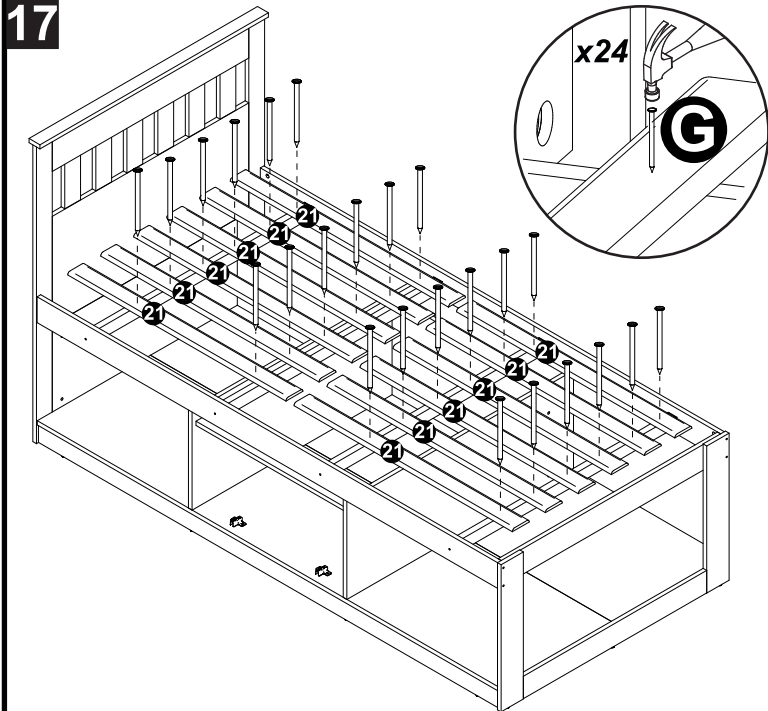

18

Ajuste das Portas- Ajustes de las Puertas- Doors Adjustment

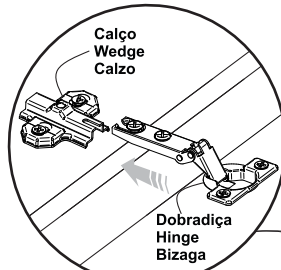
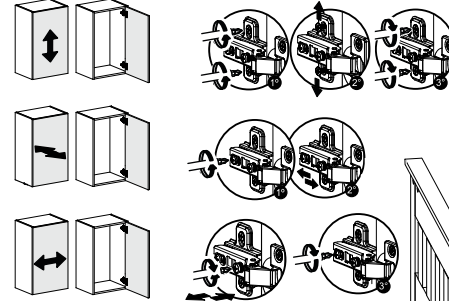

Colocar a dobradiça sobre o calço. / Place the hinge on the wedge. / Colocar la bisagra sobre el calzo.

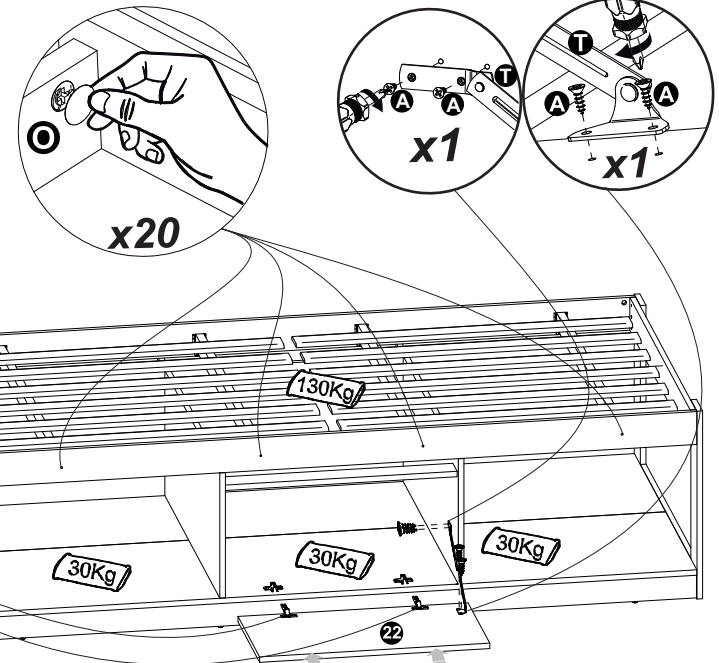

19

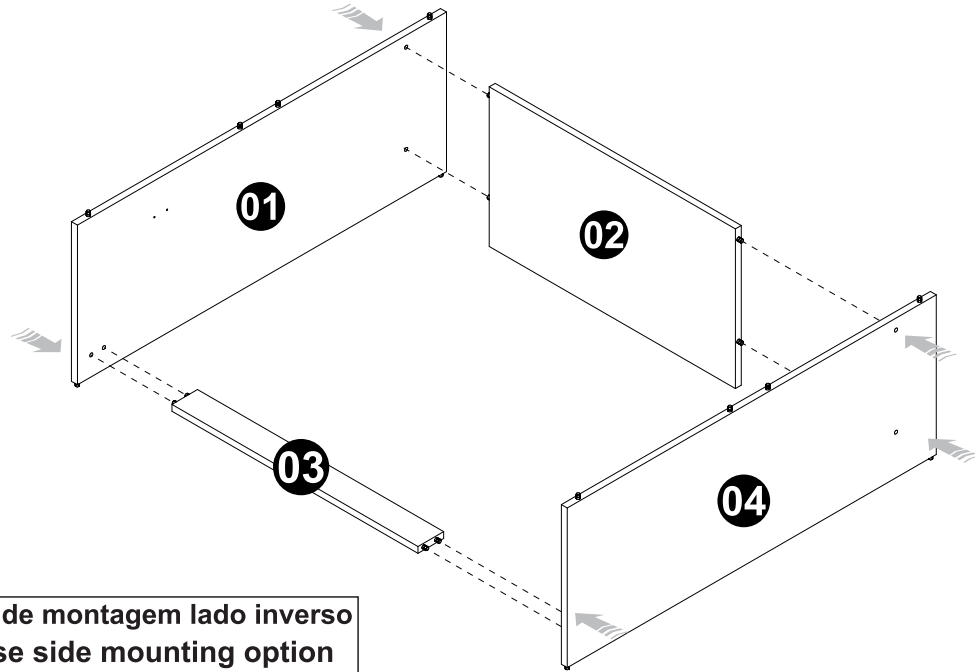

Opção de montagem lado inverso  
 Reverse side mounting option  
 Opcion de montaje en el reverso

20

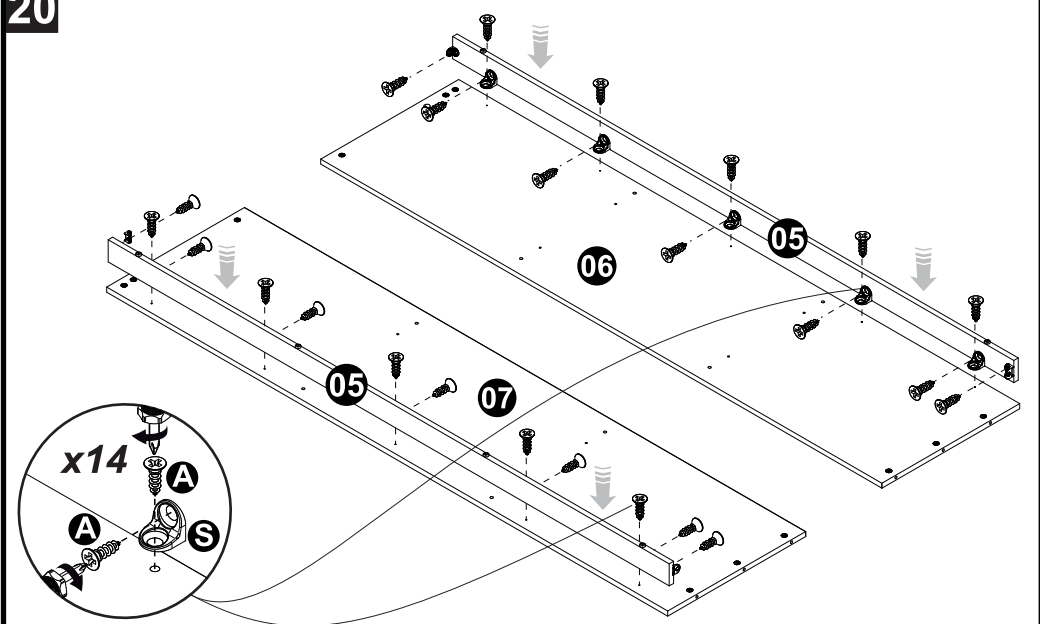

21

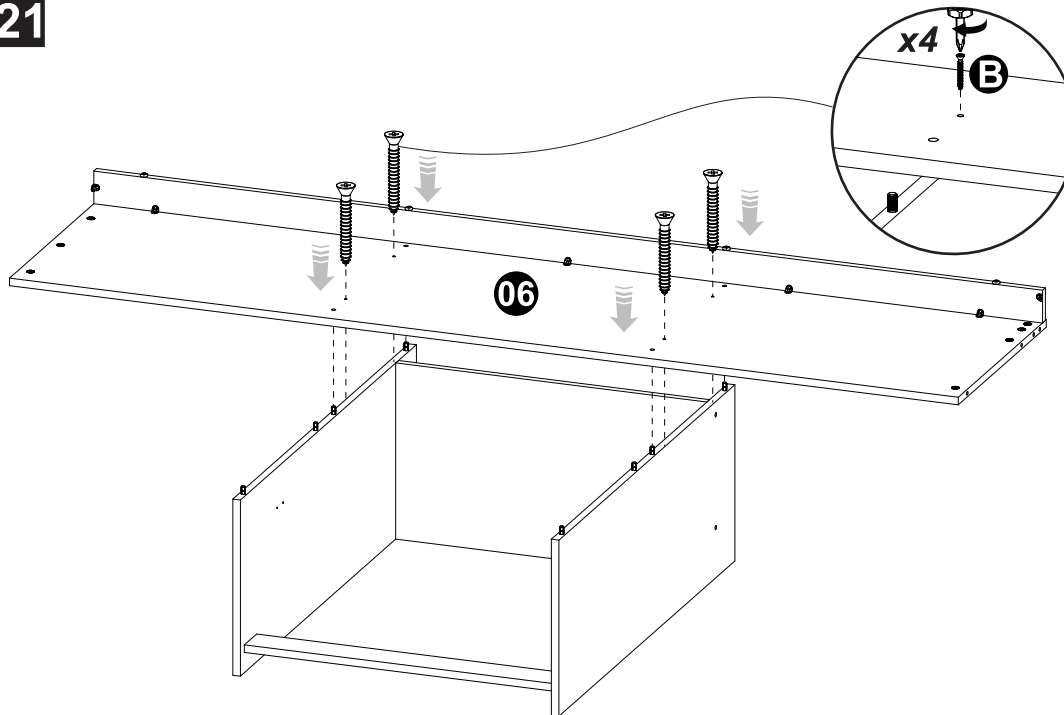

22

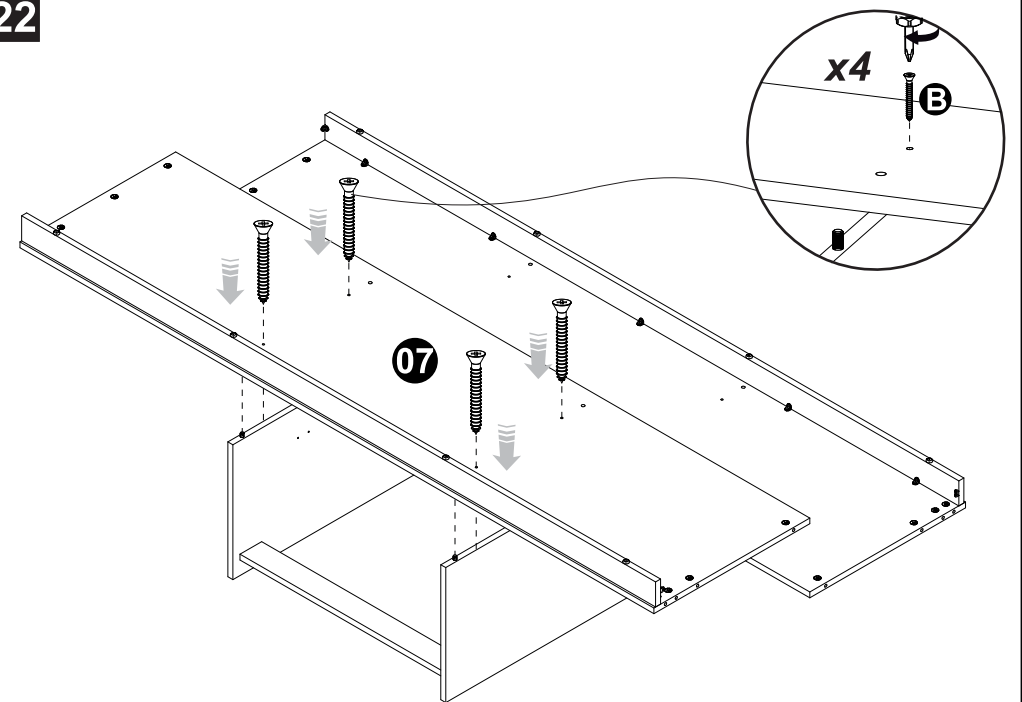

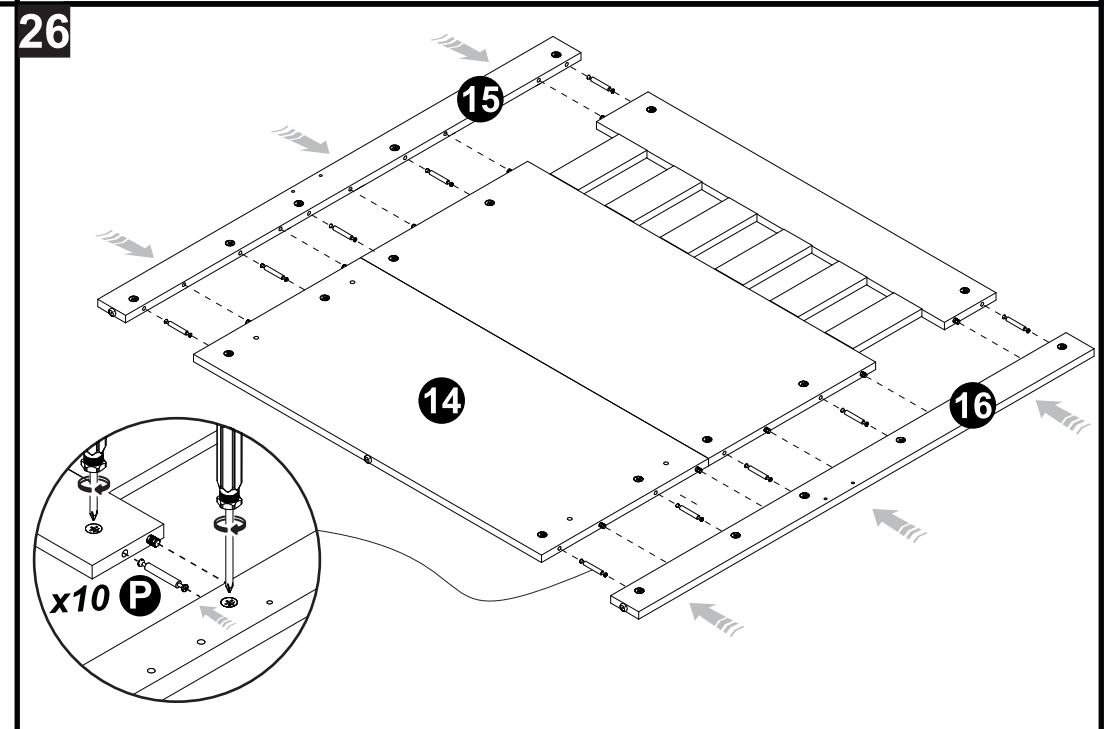
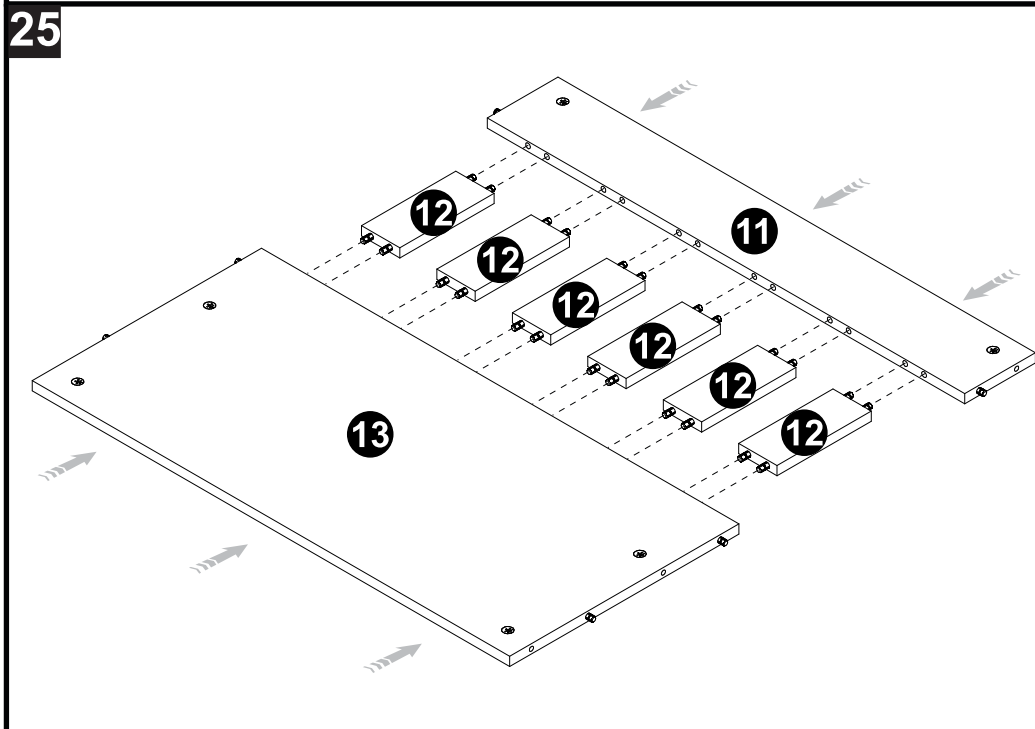
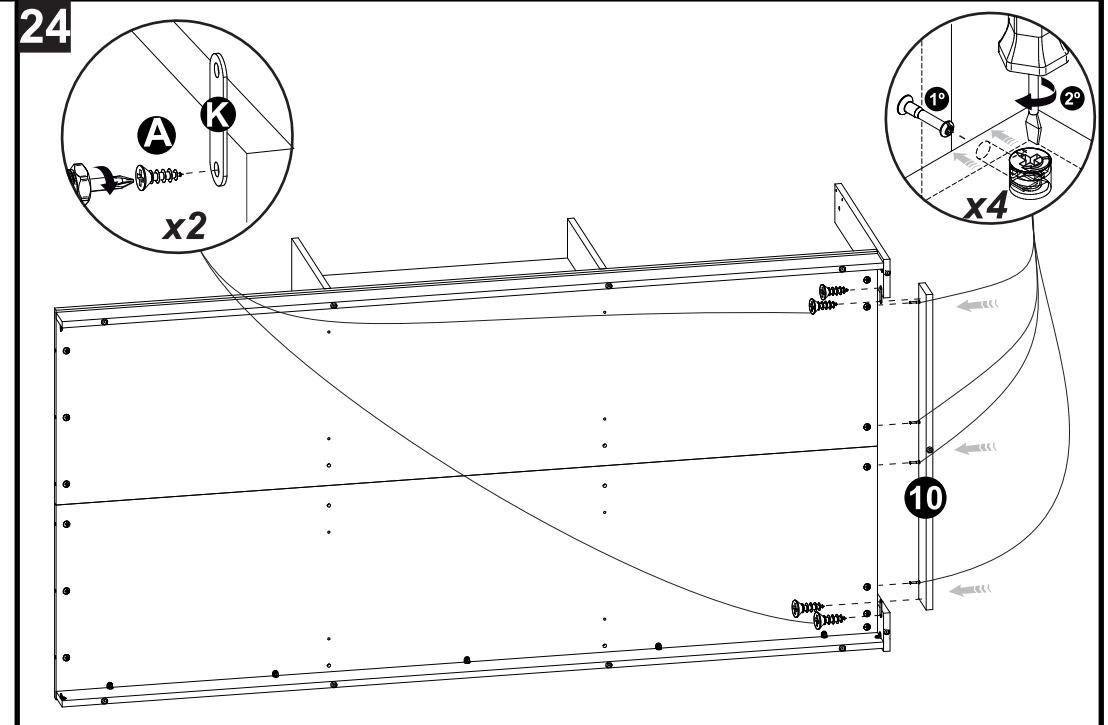
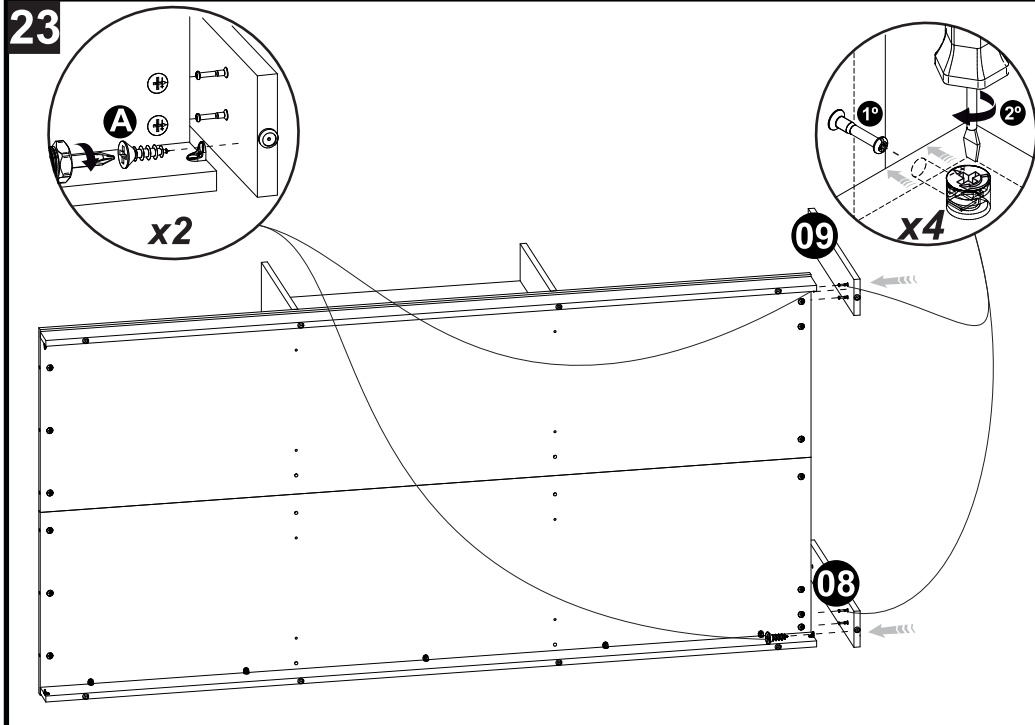



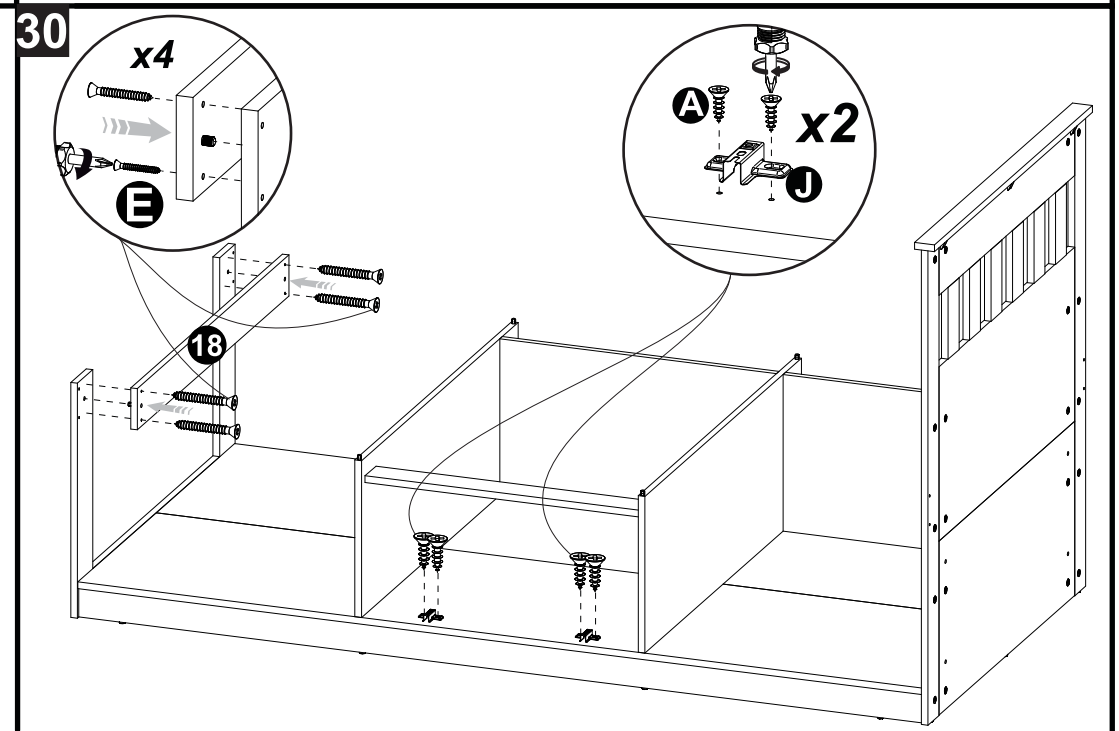
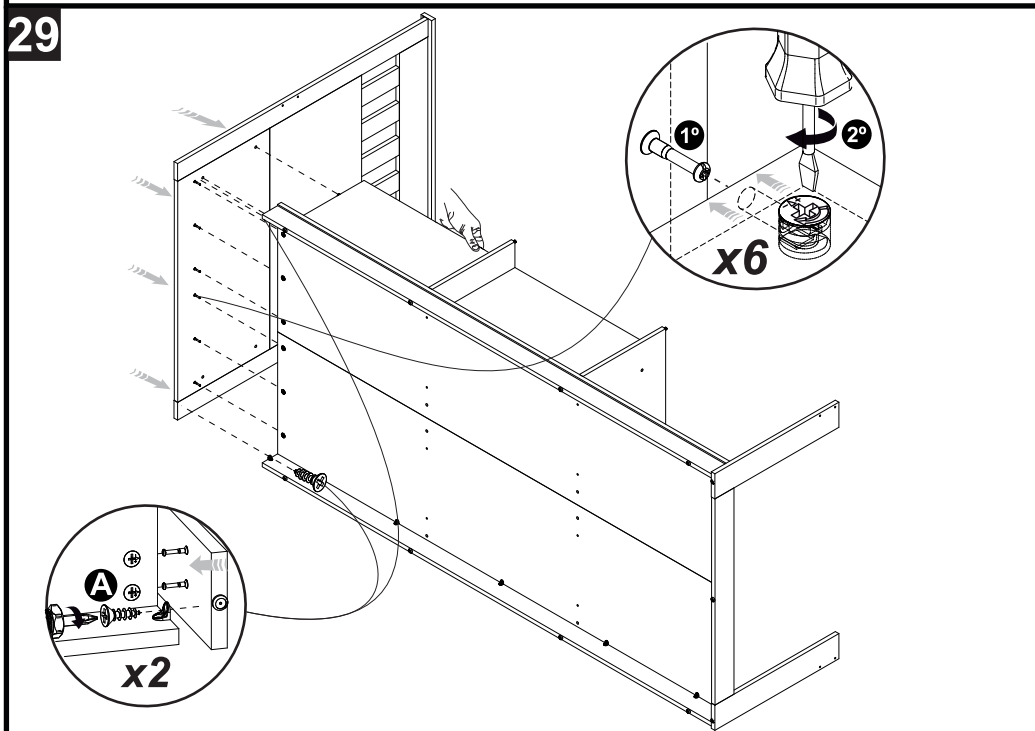
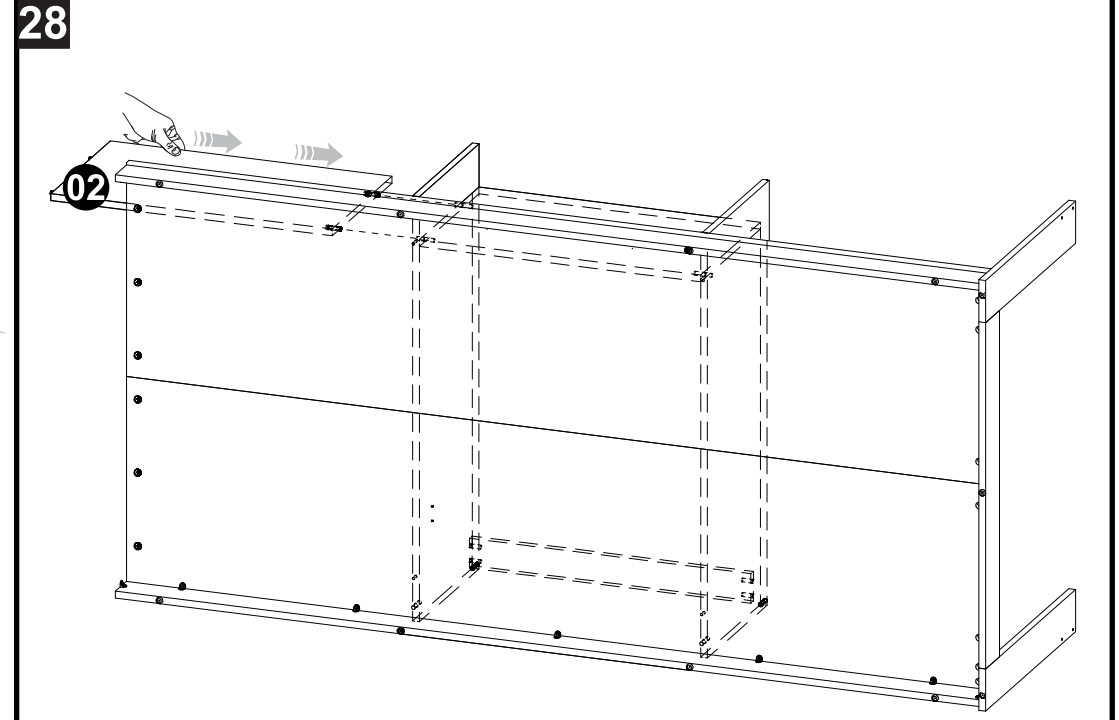
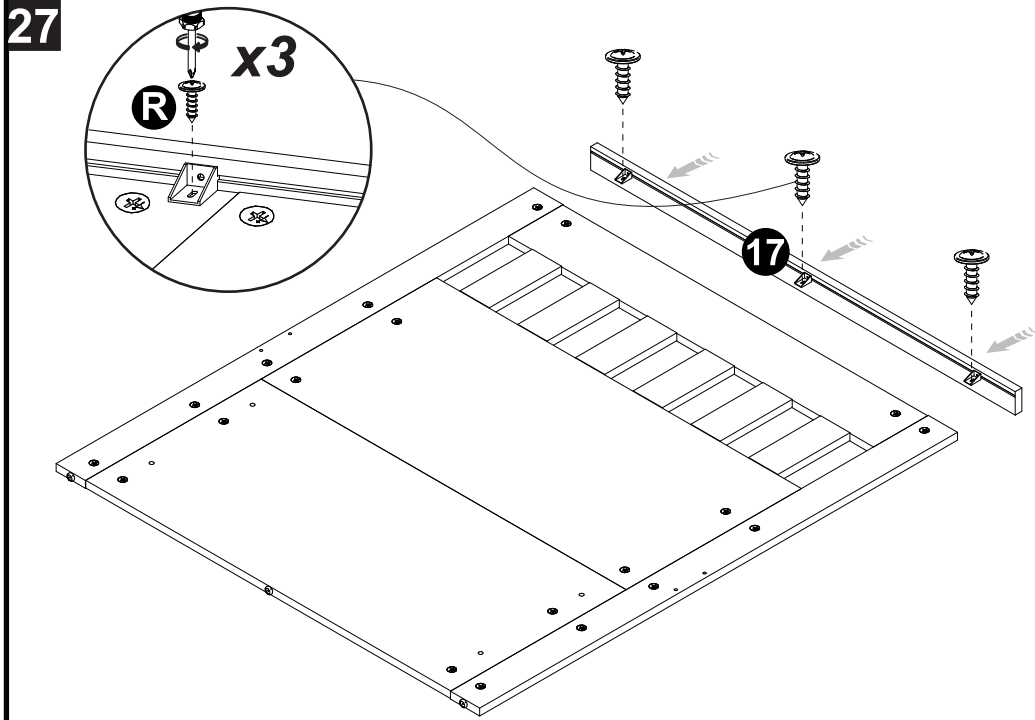

31

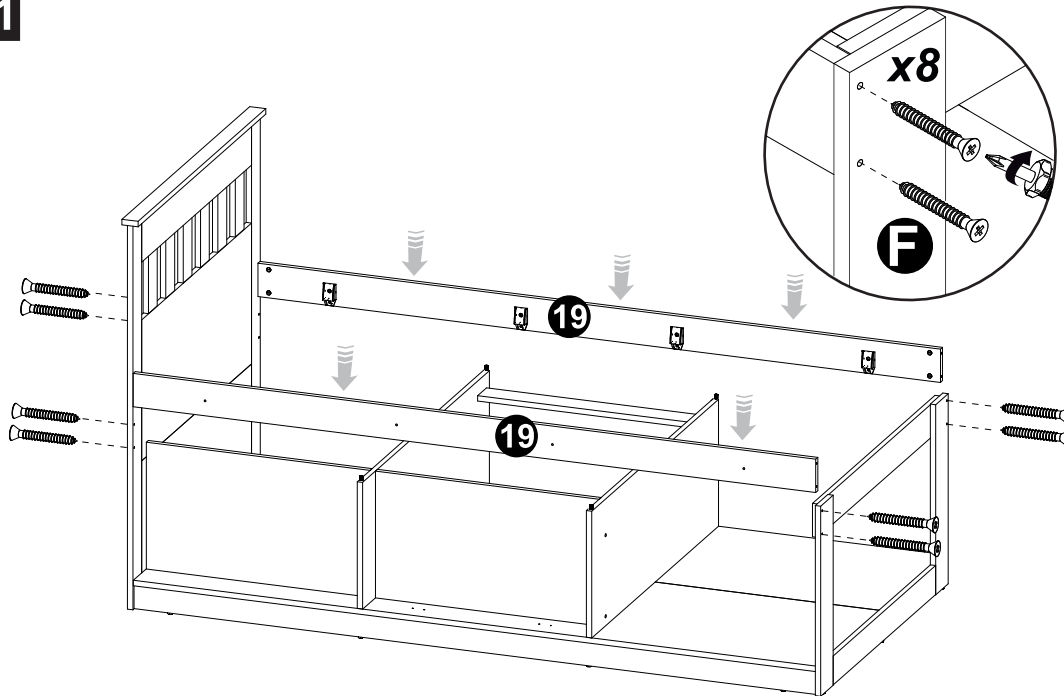

32

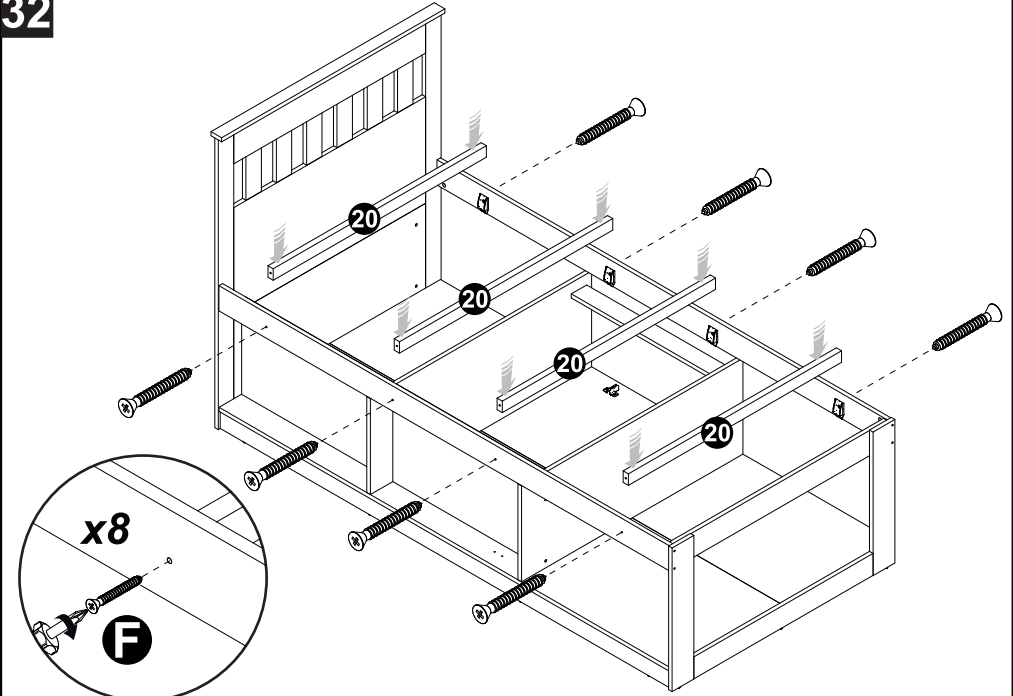

33

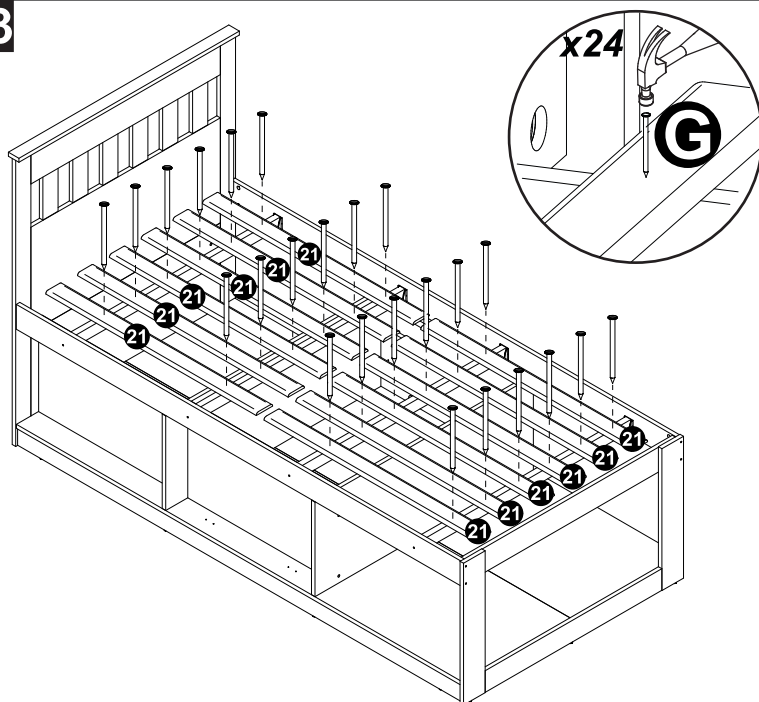

34

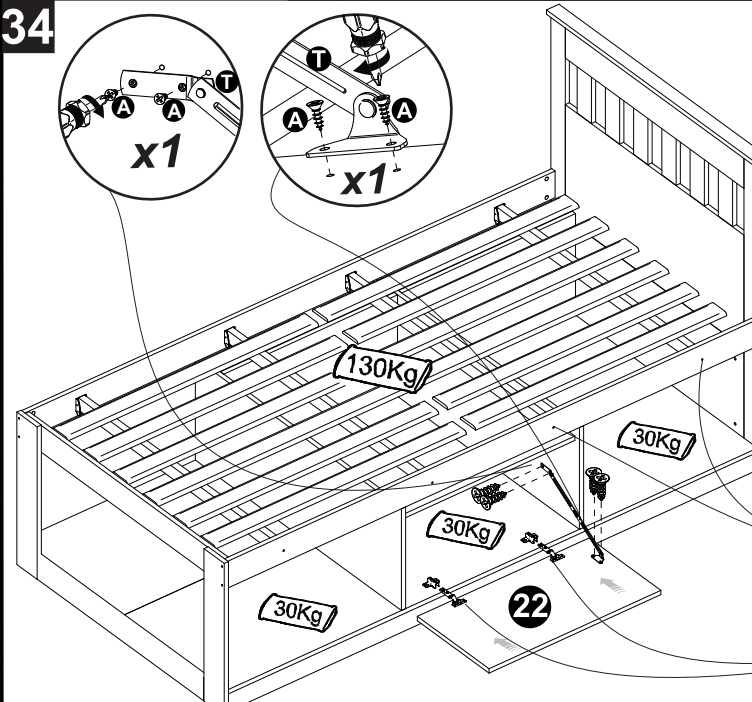

Ajuste das Portas- Ajustes de las Puertas- Doors Adjustment

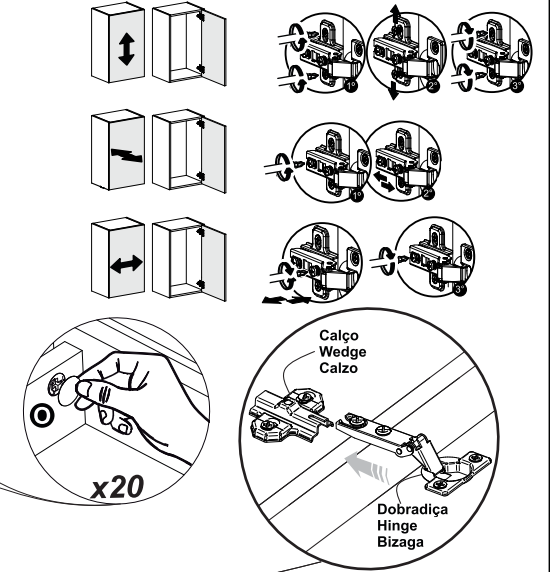

Colocar a dobradiça sobre o calço. / Place the hinge on the wedge. / Colocar la bisagra sobre el calzo.