

# INSTRUÇÕES DE MONTAGEM **CÔMODA**

Instrucciones de armado

CÓMODO / COMFORTABLE

## Ref. D024

COD. FERRAGEM: 16014

**Móveis Rodial Ltda**

Rua João Guadagnin, 5050  
Bairro Industrial I  
CX. Postal 41 - Cep: 95.300-000  
Fone/Fax: (54) 3358 6700  
Lagoa Vermelha-RS - Brasil  
sac@rodial.com.br



www.rodial.com.br



Altura: **1353mm**

Altura: 1353mm

Largura: **1207mm**

ancho: 1207 mm

Profundidade: **400**

profundidad: 400mm **mm**

**Pessoas Necessárias para montagem**  
las personas necesarias para el montaje



1 Pessoa / 1 persona

(Não Fornecidas)  
(No se proporcionaron)

**Ferramentas para a montagem**  
Herramientas para el montaje



Martelo  
martillo

Chave Philips ou  
Parafusadeira  
Destornillador Philips o una llave

### ATENÇÃO

- Ler e observar atentamente toda a instrução antes de iniciar a montagem.
- A montagem do produto deverá ser feita em superfície limpa e plana.
- Aconselhamos utilizar a embalagem para forrar o chão a fim de não danificar o produto.
- Evitar batidas e o contato com objetos cortantes.
- Observar as cargas máximas suportadas de acordo com o desenho.

### LIMPEZA

- Pano levemente umedecido com água seguido de pano seco.
- Não utilizar produtos químicos e abrasivos.

### ATENCIÓN

- Lea y siga todas las instrucciones cuidadosamente antes de iniciar el montaje.
- El montaje del producto debe estar en una superficie limpia y plana.
- Recomendamos utilizar el embalaje para cubrir el suelo con el fin de no dañar producto.
- Eviten los golpes y el contacto con objetos punzantes.

### LIMPIEZA

- Paño ligeramente humedecido con agua, seguido por un paño seco.
- No utilice productos químicos y abrasivos.

## Relação de Acessórios / relación de las partes

Letra	Nome do Acessório	Quantidade	Cod. Peça	Letra	Nome do Acessório	Quantidade	Cod. Peça
A	Calço Dobradiça Metalica	04 unid.	3384	Q	Sapata Plástica L	03 unid.	3878
B	Dobradiça Metalica	04 unid.	3384	R	Prego 10x10	80 unid.	3875
C	Parafuso 4,5x50	21 unid.	3986	S	Suporte Cabideiro	02 unid.	3884
D	Porca Plastica 12x9	21 unid.	3874	T	Parafuso 3,5x30	12 unid.	3870
E	Parafuso 3,5 x12	40 unid.	3385	U	cantoneira metalica 18x18	11 unid.	3882
F	Cavilha 06x30	36 unid.	3881	V	Prego 12x12	12 unid.	3876
H	Corrediça 350mm	04 CJ.	16452	X	Etiqueta Logomarca	01 unid.	10722
I	Parafuso 3,5x12 Corrediça	48 unid.	5738				
J	Cola 10gr	01 unid.	3872				
L	Suporte Prateleira	04 unid.	3883				
N	Puxador 256mm	06 unid.	10425				
P	Sapata Plástica 15mm	03 unid.	15597				



www.rodial.com.br

<b>RELAÇÃO DE PEÇAS</b> Relation of pieces <i>Relación de piezas</i>			<b>QUANT.</b> Quant. <i>Cuant.</i>
1	<b>Lateral gaveta</b> Lateral cajón <i>Drawer side</i>	360X92X12mm	08
2	<b>Traseira gaveta</b> Trasero cajón <i>Drawer back</i>	535X92X12mm	04
3	<b>Fundo gaveta</b> Fondo cajón <i>Front drawer</i>	558X366X3mm	04
4	<b>Frente gaveta</b> Frente cajón <i>Front drawer</i>	592X164X15mm	04
5	<b>Lateral esquerda</b> Lateral izquierda <i>Side left</i>	1338X385X12mm	01
6	<b>Chapéu médio</b> Tapa mediano <i>Medium top</i>	584X385X12mm	02
7	<b>Lateral esquerda comoda</b> Lateral izquierda <i>Side left</i>	735X385X12mm	01
8	<b>Lateral direita</b> Lateral derecha <i>Side right</i>	1338X385X12mm	01
9	<b>Rodapé frontal</b> Rodapié frontal <i>Front baseboard</i>	584X75X15mm	02
10	<b>Rodapé traseiro</b> Rodapié trasero <i>Back baseboard</i>	584X75X15mm	01
11	<b>Costa Pequena</b> Revés pequena <i>Small back</i>	600X263X3mm	01
12	<b>Costa comoda</b> Revés <i>Back</i>	600X432X3mm	01
13	<b>Porta grande</b> Puerta grande <i>Big Door</i>	1174X295X15mm	02
14	<b>Costa</b> Revés <i>Back</i>	1275X300X3mm	02
15	<b>Tampo superior</b> tapa superior <i>UpperTop</i>	660X410X15mm	01
16	<b>Tampo inferior</b> Tapa inferior <i>Top</i>	584X385X12mm	02
17	<b>Prateleira</b> Estanteria <i>Shelf</i>	584X385X12mm	01
18	<b>Pau de Cabide</b> Madera de percha <i>Hanger wood</i>	580 mm	01
19	<b>Perfil H</b> Perfil H <i>Perfil H</i>	1275 mm	01

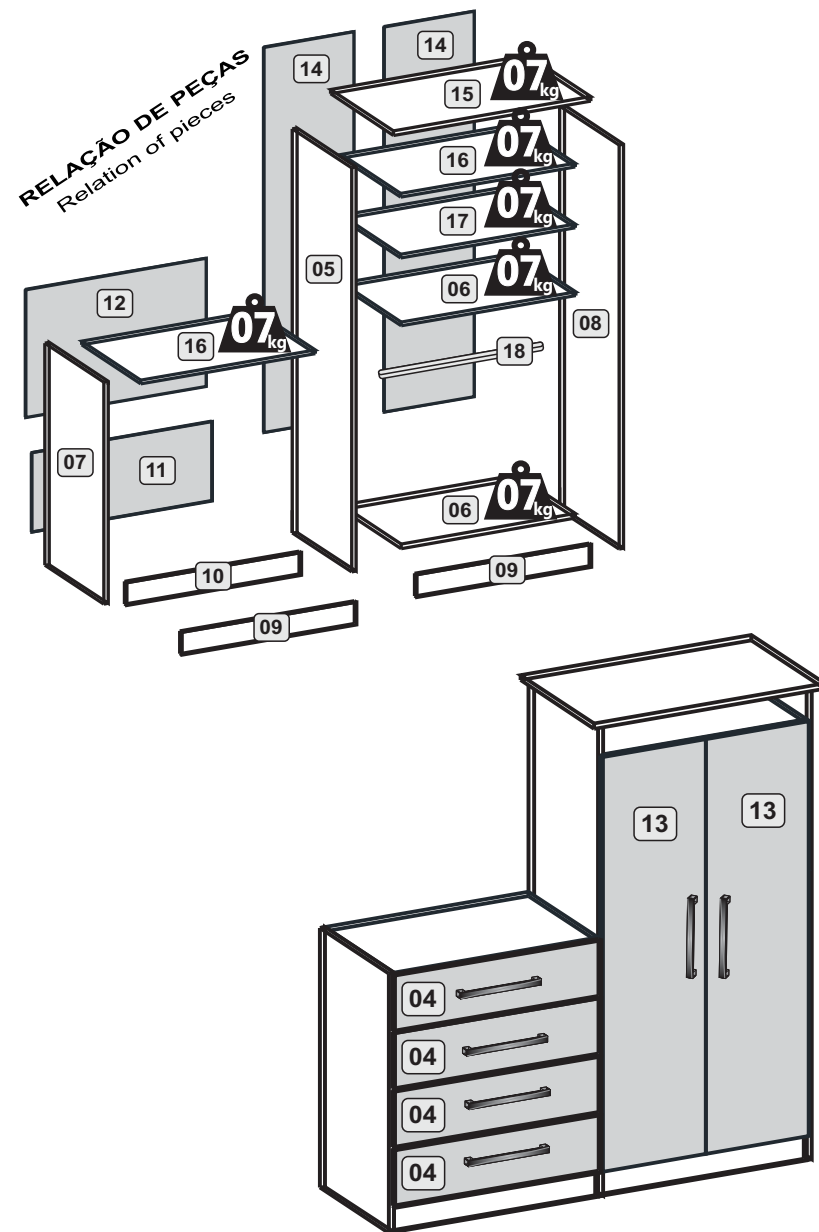

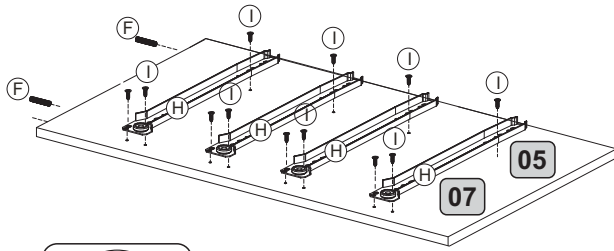

**1º** 1º Passo  
1th Step  
Paso 1

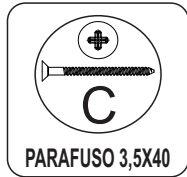

**2º** 2º Passo  
2th Step  
Paso 2

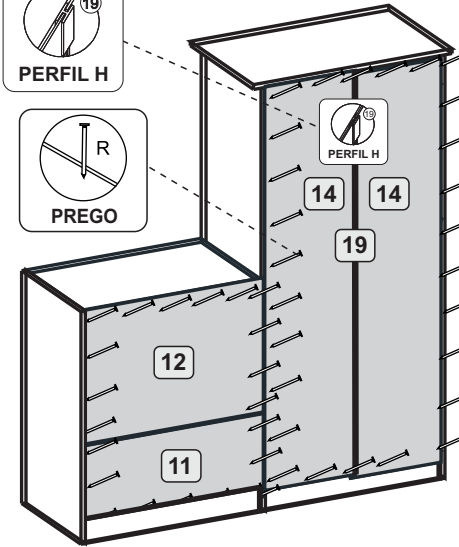
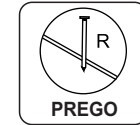
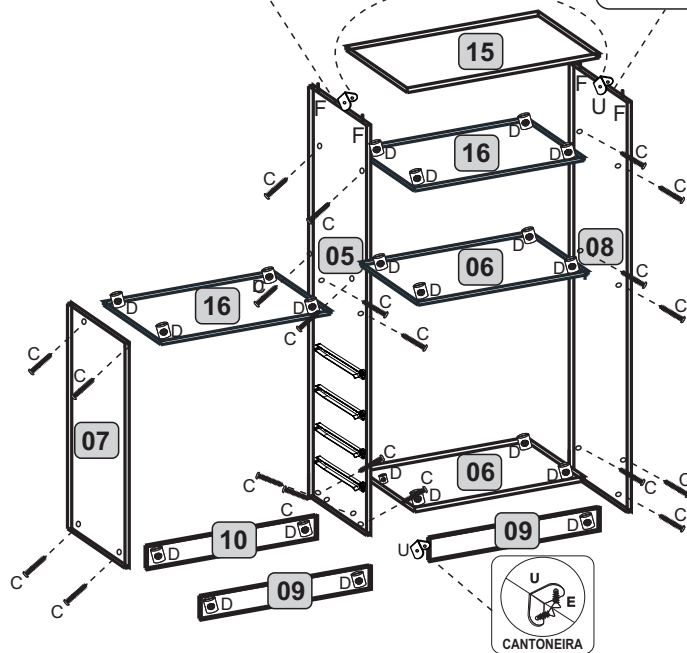
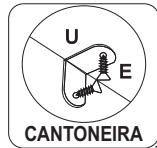

**3º** 3º Passo  
3th Step  
Paso 3

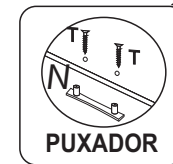
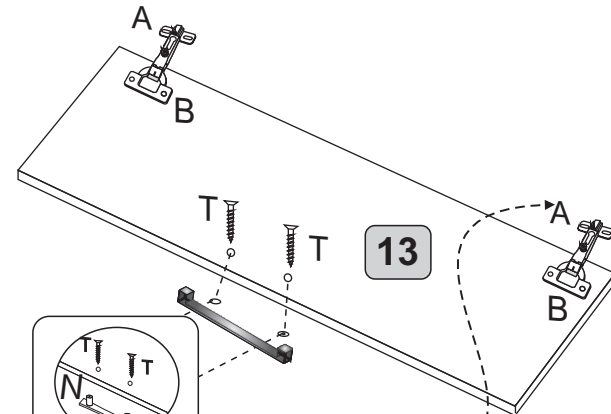

**4º** 4º Passo  
4th Step  
Paso 4

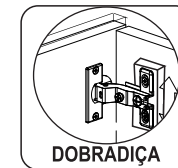

## MONTAGEM DAS GAVETAS / ARMADO EL CAJÓN

Atenção!!! Utilizar Cola nas Cavilhas e Fundo da Gaveta.  
Attention! To use Glue in Cavilhas and Deep of the Drawer.

### 5º PASSO

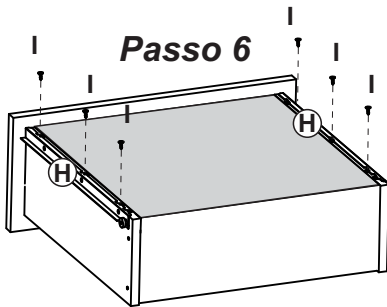
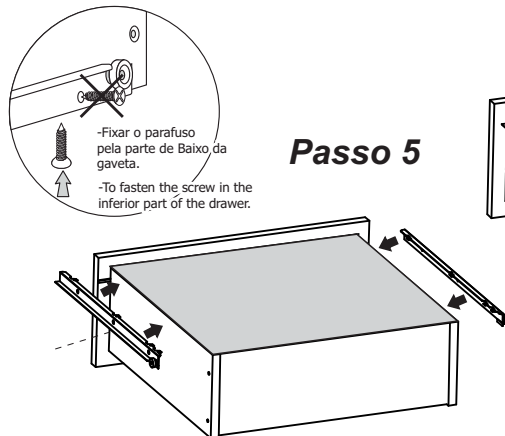
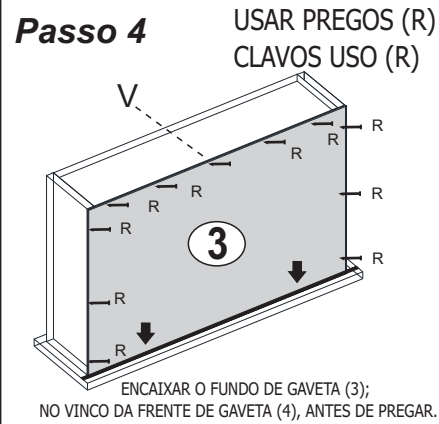
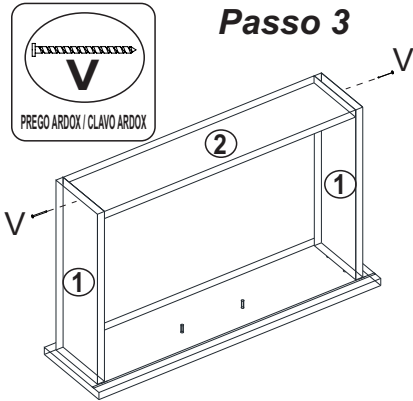
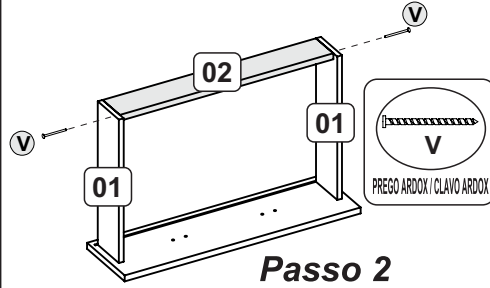
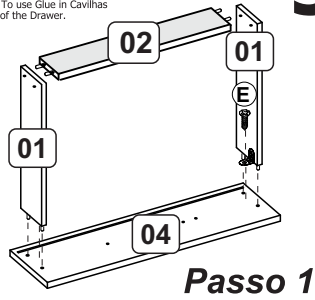

**RODIAL**  
www.rodial.com.br

### 6º Passo 5th Step Paso 5

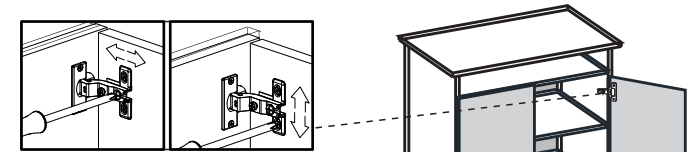
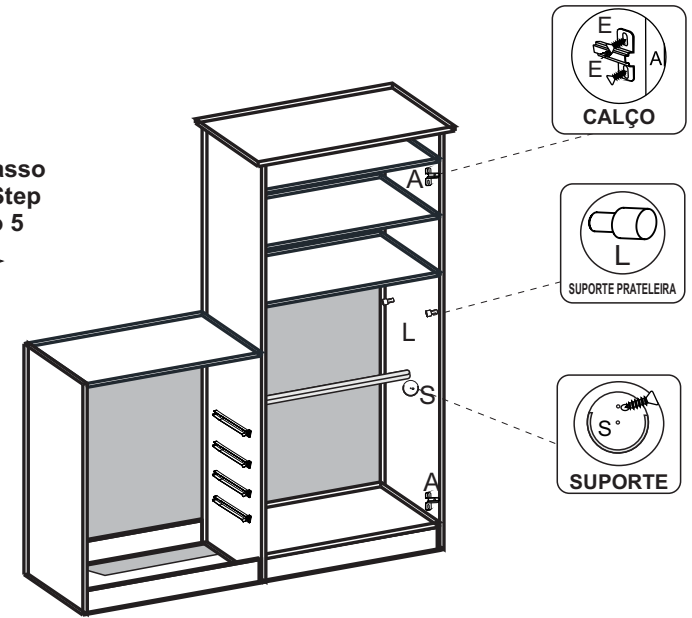

REGULAGEM

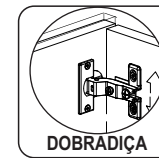

### 7º Passo 6th Step Paso 6

