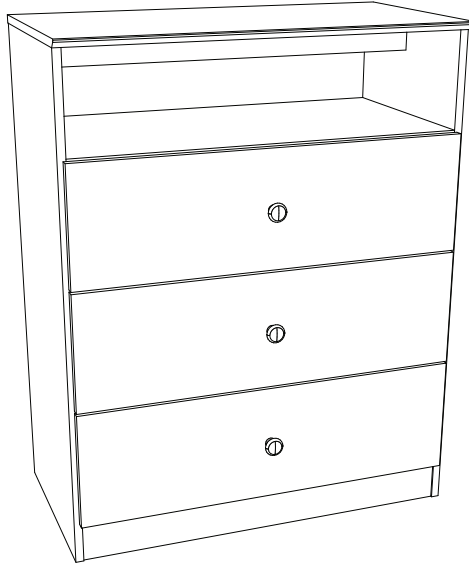

HENNInd. e Com. de Móveis Henn
Mondai - SC - Brasil

☎ +55 49 3674.3500

📱 @moveishenn
www.henn.com.br**INSTRUÇÕES DE
MONTAGEM****INSTRUCCIONES DE MONTAJE
ASSEMBLY INSTRUCTIONS****CÔMODA MAGIA 03 GAVETAS |
CÓMODA MAGIA 03 CAJONES | MAGIA CHEST OF DRAWERS 03**

I726-190 Branco/Jequitibá HP

**AVISO**

Para limpeza de seu móvel, use uma flanela seca ou umedecida, e não utilize produtos químicos que possam danificar seu produto.

SISTEMA DE MONTAGEM

O sistema de montagem dos produtos, funciona de acordo com a ordem crescente dos números indicados no desenho. Ex: 01, 02, 03, 04... até a conclusão da montagem.

ASSISTÊNCIA TÉCNICA

Para solicitação de Assistência Técnica você consumidor deverá entrar em contato com o Lojista o qual você realizou a compra deste produto e solicitar a assistência técnica das peças avariadas. A garantia abrange todas as peças, partes e componentes que eventualmente venham apresentar defeito de fabricação no prazo de 03 (três) meses, contando a partir da entrega do produto ao consumidor, mediante nota fiscal de compra. Se houver qualquer alteração na estrutura do produto ou ocorrer defeito por negligência do montador/consumidor em relação a instrução de montagem e manuseio, não será fornecido assistência técnica gratuita.

ADVERTENCIA

Para limpieza de su móbil, use una flanela seca o húmeda, y no utilice productos químicos que puedan dañar su producto.

SISTEMA DE MONTAJE

El sistema de montaje de los productos funciona de acuerdo con el orden creciente de los números indicados en el dibujo. Ej.: 01, 02, 03, 04... hasta la conclusión del montaje.

ASISTENCIA TÉCNICA

Para solicitar Asistencia Técnica, el consumidor debe comunicarse con el Comercio que usted realizó la compra de este producto y solicita asistencia técnica para las partes dañadas. La garantía cubre todas las partes, piezas y componentes que eventualmente puedan presentar defecto de fabricación en el plazo de 03 (tres) meses, contados a partir de la entrega del producto al consumidor, mediante factura de compra. Si se produce algún cambio en la estructura del producto o se produce un defecto por negligencia del montador/consumidor en relación con las instrucciones de montaje y manipulación, no se prestará asistencia técnica gratuita.

NOTICE

To clean your furniture, use a dry or wet cloth, and do not use chemicals that may damage your product.

ASSEMBLY SYSTEM

The products' assembly system works according to the increasing order of the indicated numbers. For example: 01, 02, 03, 04 ... to the end of the assembly.

TECHNICAL ASSISTANCE

To request Technical Assistance, the consumer must contact the retailer from whom you purchased this product and request technical assistance for the damaged parts. The warranty covers all parts, parts and components that may eventually present a manufacturing defect within a period of 03 (three) months, counting from the delivery of the product to the consumer, by means of a purchase invoice. If there is any change in the structure of the product or defect occurs due to negligence of the assembler/consumer in relation to the assembly and handling instruction, free technical assistance will not be provided.

ACESSÓRIOS | ACCESORIOS | ACCESSORIES

A	x1	B	x8	C	x3	D	x62	E	x6
---	----	---	----	---	----	---	-----	---	----

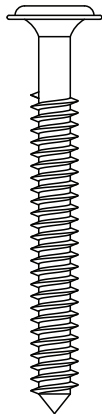

5,0x50mm



3,5x40mm



3,5x25mm



3,5x12mm



3,0x16mm

F	x42	G	x10	H	x34	I	x6	J	x12
---	-----	---	-----	---	-----	---	----	---	-----

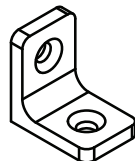
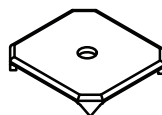
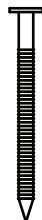
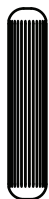

K	x3	L	x6	M	x3	N	x3	O	x4
---	----	---	----	---	----	---	----	---	----

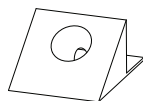
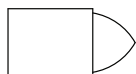

PAR

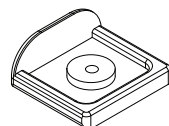

ACESSÓRIOS | ACCESORIOS | ACCESSORIES

P x1 Q x1 R x1 S x1 T x8

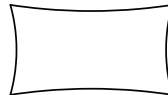
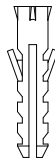
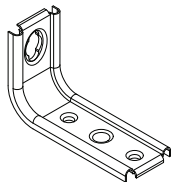

LISTA DE PEÇAS | LISTA DE PIEZAS | LIST OF PIECES

Item	Caixa Caja Box	Qtd Ctd Qty	Descrição Descripción Description	Dimensões (mm) Dimensiones (mm) Dimensions (mm)		
				Comprimento Largo Length	Largura Ancho Width	Espessura Grosor Thickness
1	1/1	1	LATERAL ESQUERDA LADO IZQUIERDO LEFT SIDE	929	380	15
2	1/1	1	RODAPÉ FRONTAL FALDÓN DELANTERO FRONT SKIRTING	720	73	12
3	1/1	1	RODAPÉ TRASEIRO PIE TRASERO REAR SKIRTING BOARD	720	73	12
4	1/1	1	TRAVESSA ESTRUTURAL VIGA ESTRUTURAL STRUCTURAL CROSSBOW	720	73	12
5	1/1	1	TAMPO DAS GAVETAS TAPA DE LOS CAJONES TOP OF DRAWERS	720	380	15
6	1/1	1	TRAVESSA SUPORTE BANDEJA DE SOPORTE SUPPORT CROSSBOW	720	60	15
7	1/1	1	LATERAL DIREITA LADO DERECHO RIGHT SIDE	929	380	15
8	1/1	1	TAMPO TAPA TOP	752	396	15
9	1/1	1	FUNDO SUPERIOR FONDO MÁS ALTO TOP BOTTOM	744	200	3
10	1/1	2	FUNDO CRU FONDO CRUDO RAW BOTTOM	682	371	3
11	1/1	3	FRENTE DE GAVETA FRENTE DEL CAJÓN DRAWER FRONT	730	220	15
12	1/1	6	LADO DE GAVETA LATERAL DEL CAJÓN DRAWER SIDE	350	110	12
13	1/1	3	FUNDO DE GAVETA FONDO DEL CAJÓN DRAWER BOTTOM	682	361	3
14	1/1	3	RIPA DE TRÁS TRAVESAÑO TRASERO REAR CLAPBOARD	695	110	12

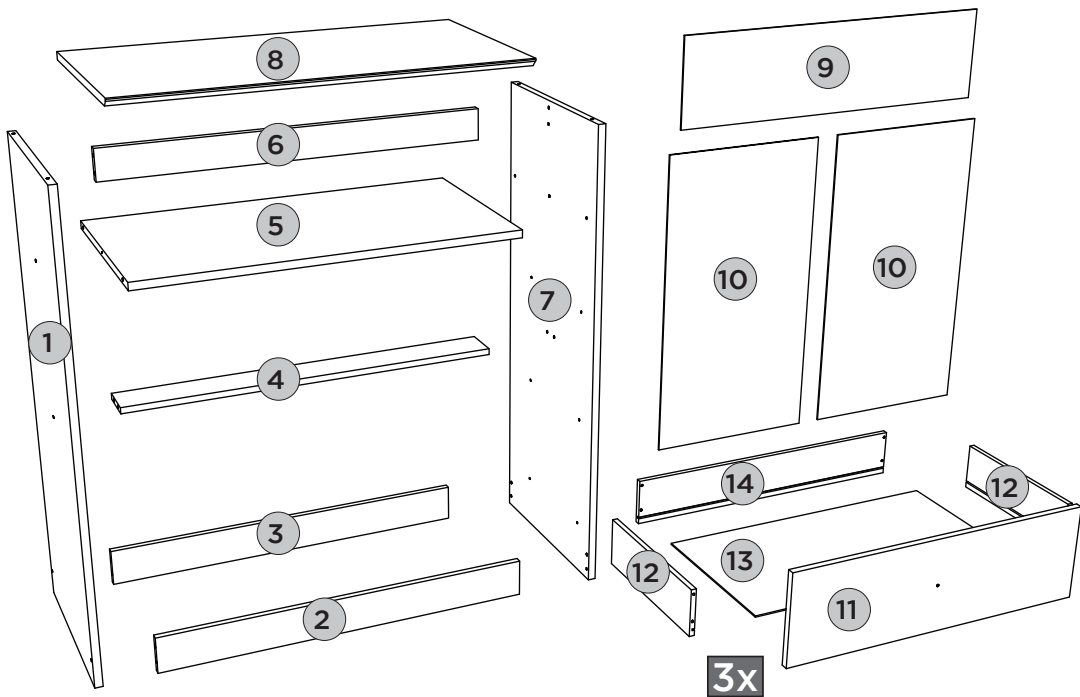

REQUISITOS PARA MONTAGEM

REQUISITOS PARA LA MONTAJE | ASSEMBLY REQUIREMENTS.

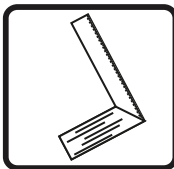
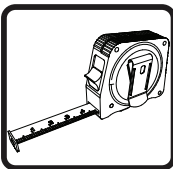
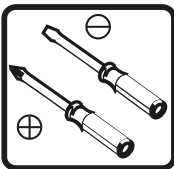
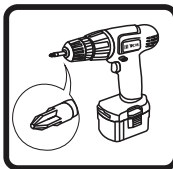

Imagens meramente ilustrativas, não acompanha o produto.





Imágenes ilustrativas, no incluidas con el producto.

Illustrative images, not included with the product.





PEÇAS REQUERIDAS

1	LATERAL ESQUERDA	x1
5	TAMPO DAS GAVETAS	x1
7	LATERAL DIREITA	x1
8	TAMPO	x1

ACESSÓRIOS REQUERIDOS

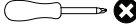
D		22
F		08
G		04
J		04
M		06

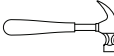
FERRAMENTAS NECESSÁRIAS

		
		
O		04
S		

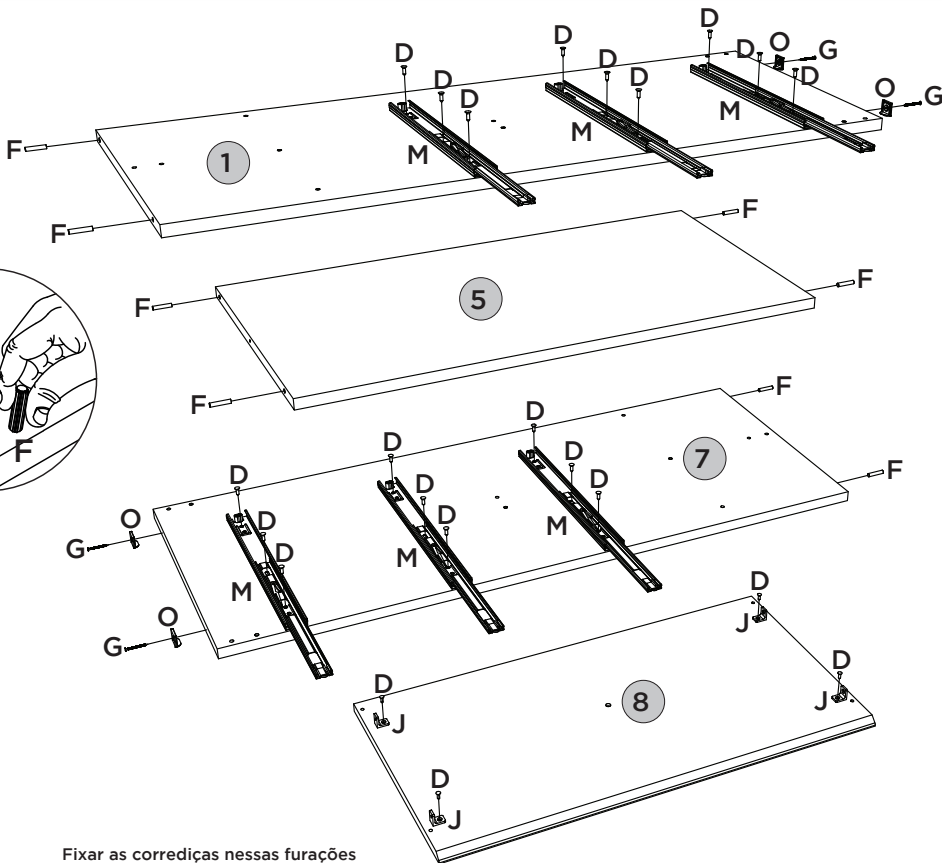



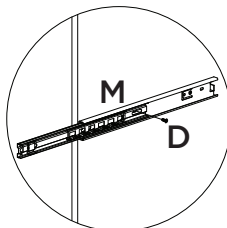
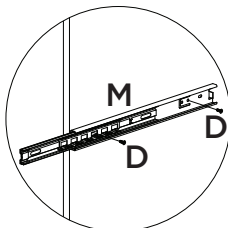
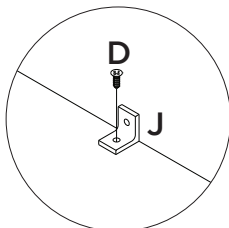
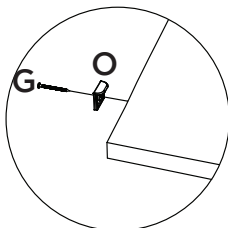
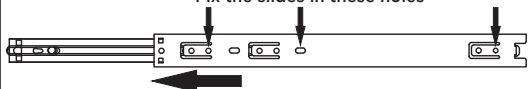

Fixar as corredeiras nessas furações
 Fijar las diapositivas de estos agujeros
 Fix the slides in these holes



PEÇAS REQUERIDAS

2	RODAPÉ FRONTAL	x1
3	RODAPÉ TRASEIRO	x1
4	TRAVESSA ESTRUTURAL	x1
6	TRAVESSA SUPORTE	x1
12	LADO DE GAVETA	x6

ACESSÓRIOS REQUERIDOS

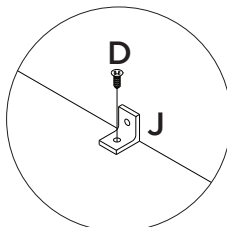
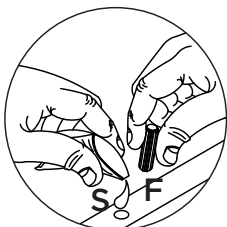
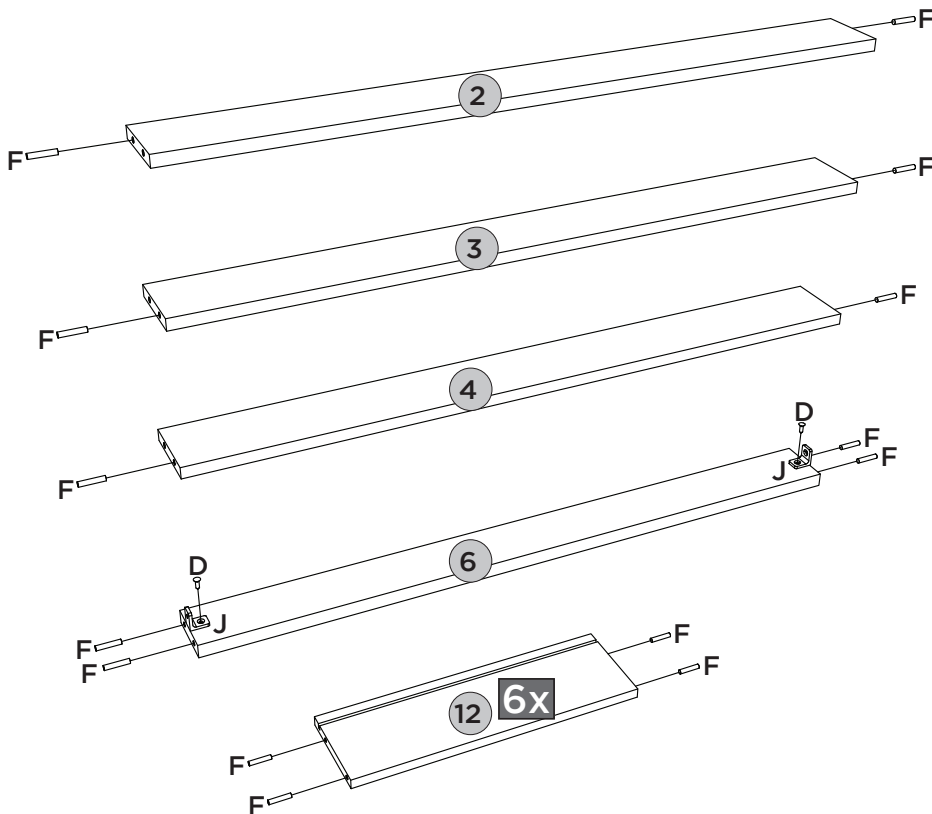
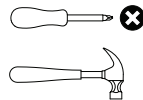

D		02
F		34
J		02
S		

FERRAMENTAS NECESSÁRIAS

PEÇAS REQUERIDAS

1	LATERAL ESQUERDA	x1
2	RODAPÉ FRONTAL	x1
3	RODAPÉ TRASEIRO	x1
4	TRAVESSA ESTRUTURAL	x1
5	TAMPO DAS GAVETAS	x1
6	TRAVESSA SUPORTE	x1
7	LATERAL DIREITA	x1

ACESSÓRIOS REQUERIDOS

B		08
D		02

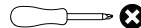
FERRAMENTAS NECESSÁRIAS



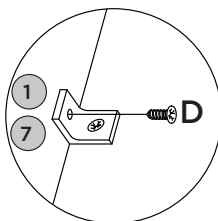
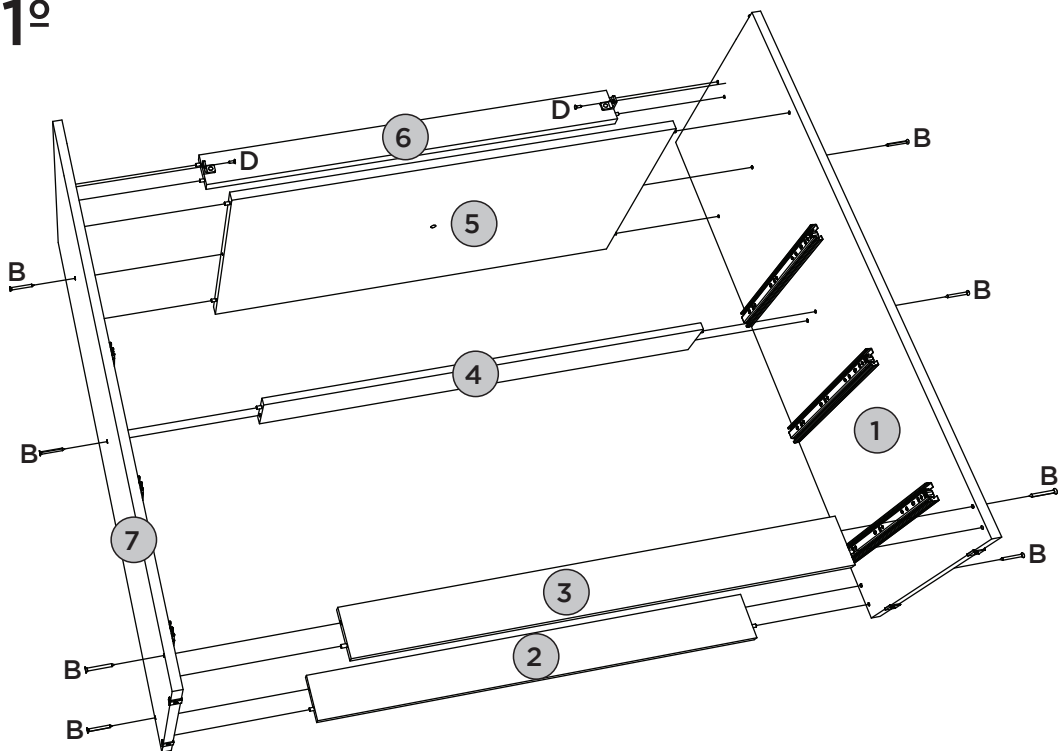

VISTA TRASEIRA

1º

PEÇAS REQUERIDAS

8	TAMPO	x1
9	FUNDO SUPERIOR	x1
10	FUNDO CRU	x2

ACESSÓRIOS REQUERIDOS

D		04
H		34
I		06
P		01

FERRAMENTAS NECESSÁRIAS

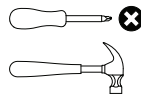

2º VISTA TRASEIRA

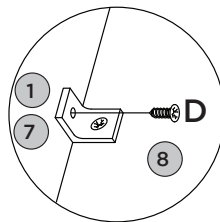
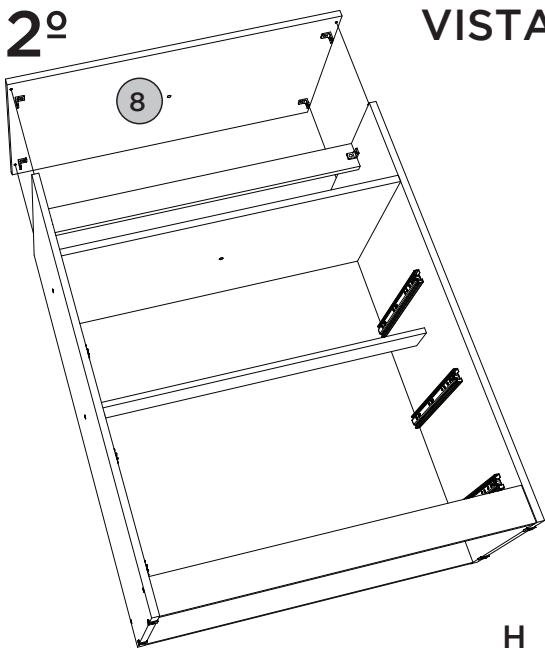



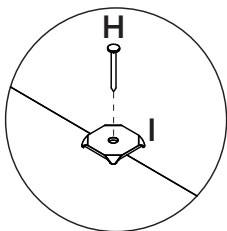
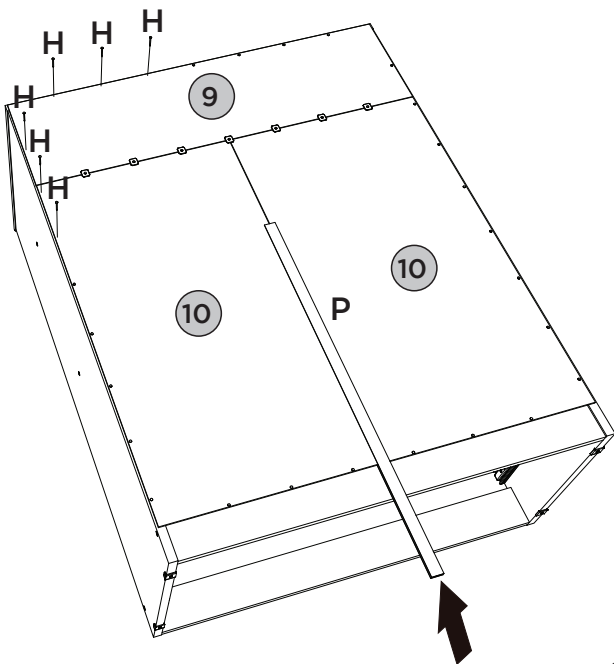

3º



PEÇAS REQUERIDAS

11	FRENTE DE GAVETA	x3
12	LADO DE GAVETA	x6
13	FUNDO DE GAVETA	x3
14	RIPA DE TRÁS	x3

ACESSÓRIOS REQUERIDOS

D		12
J		06
G		06
S		

FERRAMENTAS NECESSÁRIAS

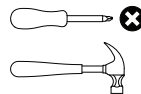

4º 3x

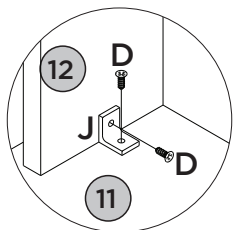
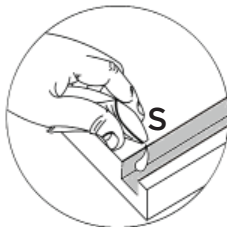
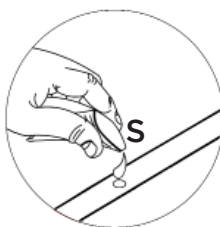
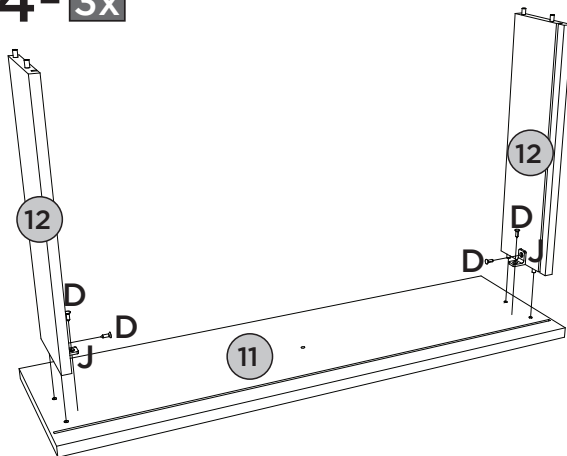



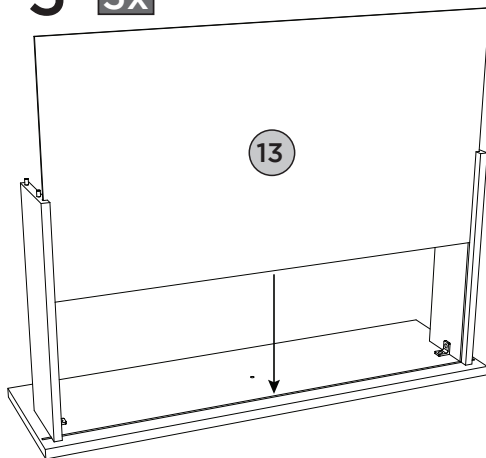

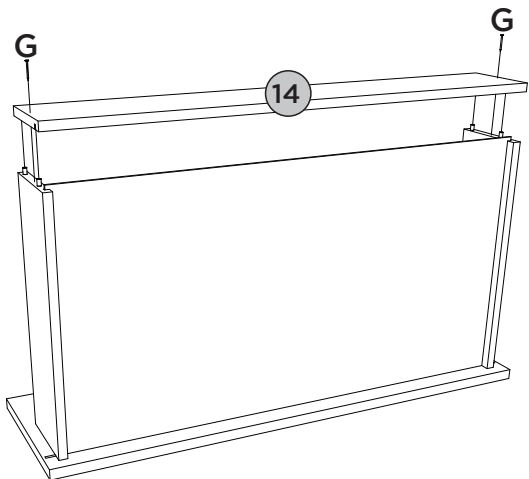

5º 3x







6º 3x



ACESSÓRIOS REQUERIDOS

C			03
D			18
E			06
L			06

FERRAMENTAS NECESSÁRIAS

		
M		06
N		03

7º 3x

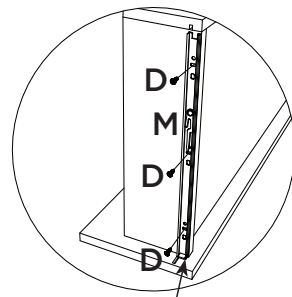
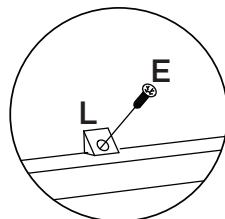
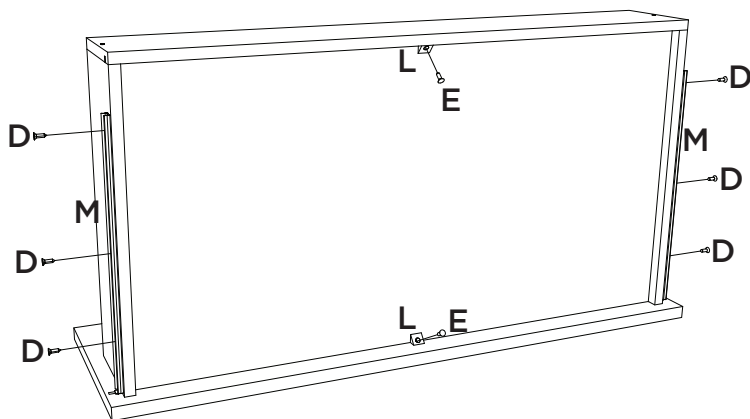

Deixar 3mm de distância da frente de gaveta.

Deje una separación de 3mm del frente del cajón.

Leave 3mm away from the front of the drawer.

8º 3x

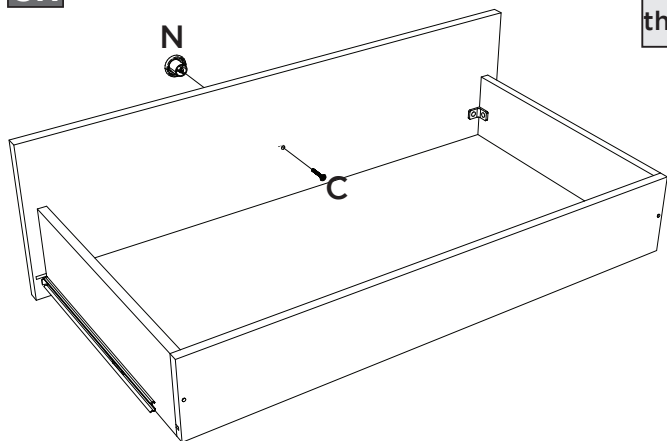

ACESSÓRIOS REQUERIDOS

A		01
D		02
K		03
Q		01
R		01
T		08

FERRAMENTAS NECESSÁRIAS

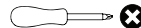

9º

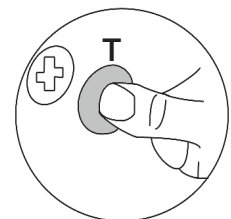
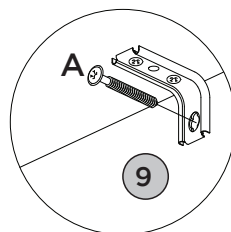
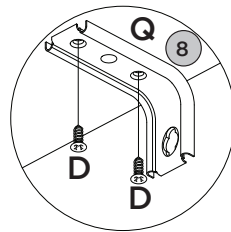

**PERFECT CORRECTION
CORRECCIÓN PERFECTA**

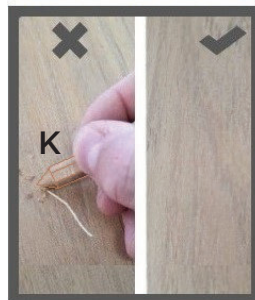

**Pesos máximos recomendados com carga distribuída.
Peso máximo recomendado con la carga distribuida.
Recommended maximum weights with evenly distributed.**

PRODUTO CONCLUÍDO
PRODUCTO TERMINADO
FINISHED PRODUCT

