

HENN

Ind. e Com. de Móveis Henn
Mondai - SC - Brasil

+55 49 3674.3500

@moveishenn
www.henn.com.br

ITM/D737-
**INSTRUÇÕES DE
MONTAGEM**

**INSTRUCCIONES DE MONTAJE
ASSEMBLY INSTRUCTIONS**

Comoda Ravenna 06 Gavetas | C6moda Ravenna 06 Cajones | Dresser Ravenna 06 Drawers

D737-127 Nature/Off White

D737-130 Castanho HP II

D737-198 Jequitib6 Brilho

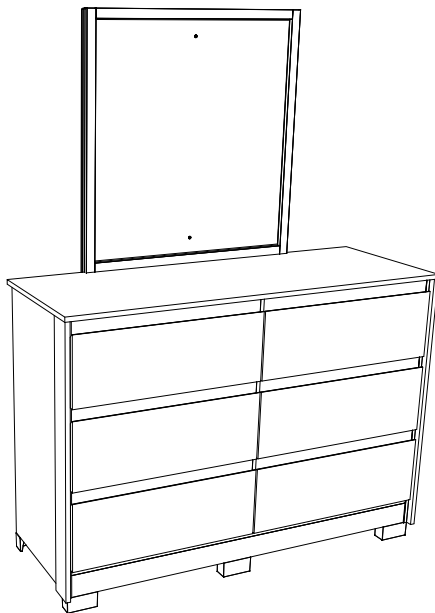
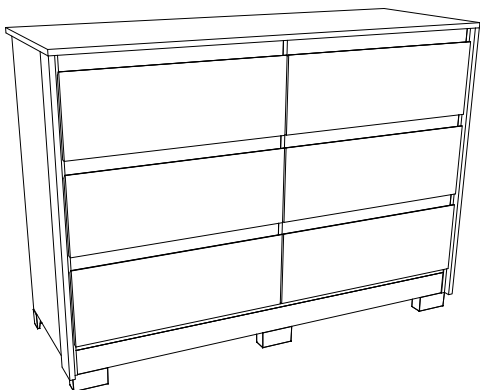

Requisitos para montagem Requisitos para la montaje Assembly Requirements

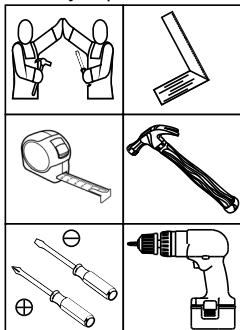

Imagens meramente ilustrativas,
n6o acompanha o produto.
Im6genes ilustrativas, no incluidas
con el producto.
Illustrative images, not included
with the product.

AVISO

Para limpeza de seu m6ovel, use uma franela seca ou umedecida, e n6o utilize produtos qu6imicos que possam danificar seu produto.

SISTEMA DE MONTAGEM

O sistema de montagem dos produtos, funciona de acordo com a ordem crescente dos n6umeros indicados no desenho. Ex: 01, 02, 03, 04... at6 a conclus6o da montagem.

ASSIST6NCIA T6CNICA

Para solicita6o de Assist6ncia T6cnica voc6 consumidor dever6 entrar em contato com o Lojista o qual voc6 realizou a compra deste produto e solicitar a assist6ncia t6cnica das pe6as avariadas. A garantia abrange todas as pe6as, partes e componentes que eventualmente venham apresentar defeito de fabrica6o no prazo de 03 (tr6s) meses, contando a partir da entrega do produto ao consumidor, mediante nota fiscal de compra. Se houver qualquer altera6o na estrutura do produto ou ocorrer defeito por neglig6ncia do montador/consumidor em rela6o a instru6o de montagem e manuseio, n6o ser6 fornecido assist6ncia t6cnica gratuita.

ADVERTENCIA

Para limpieza de su m6ovil, use una franela seca o h6meda, y no utilice productos qu6imicos que puedan da6ar su producto.

SISTEMA DE MONTAJE

El sistema de montaje de los productos funciona de acuerdo con el orden creciente de los n6umeros indicados en el dibujo. Ej.: 01, 02, 03, 04... hasta la conclus6n del montaje.

ASISTENCIA T6CNICA

Para solicitar Asistencia T6cnica, el consumidor debe comunicarse con el Comercio que usted realiz6 la compra de este producto y solicita asistencia t6cnica para las partes da6adas. La garant6a cubre todas las partes, piezas y componentes que eventualmente puedan presentar defecto de fabricaci6n en el plazo de 03 (tres) meses, contados a partir de la entrega del producto al consumidor, mediante factura de compra. Si se produce alg6n cambio en la estructura del producto o se produce un defecto por negligencia del montador/consumidor en relaci6n con las instrucciones de montaje y manipulaci6n, no se prestar6 asistencia t6cnica gratuita.

NOTICE

To clean your furniture, use a dry or wet cloth, and do not use chemicals that may damage your product.

ASSEMBLY SYSTEM

The products' assembly system works according to the increasing order of the indicated numbers. For example: 01, 02, 03, 04 ... to the end of the assembly.

TECHNICAL ASSISTANCE

To request Technical Assistance, the consumer must contact the retailer from whom you purchased this product and request technical assistance for the damaged parts. The warranty covers all parts, parts and components that may eventually present a manufacturing defect within a period of 03 (three) months, counting from the delivery of the product to the consumer, by means of a purchase invoice. If there is any change in the structure of the product or defect occurs due to negligence of the assembler/consumer in relation to the assembly and handling instruction, free technical assistance will not be provided.



x8

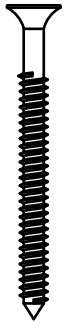

x11



x6



x40



x108

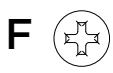

x12

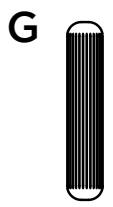

x92

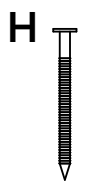

x12

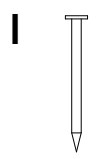

x26



x6

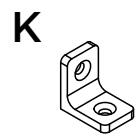

x23

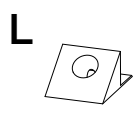

x12



x8



x6_{PAR}

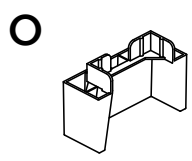

x6

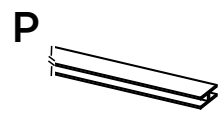

x2

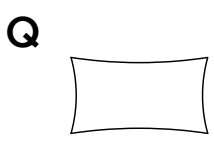

x3



x6

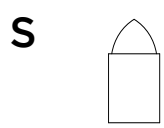

x2



HENN

x1

LISTA DE PEÇAS | LISTA DE PIEZAS | LIST OF PIECES

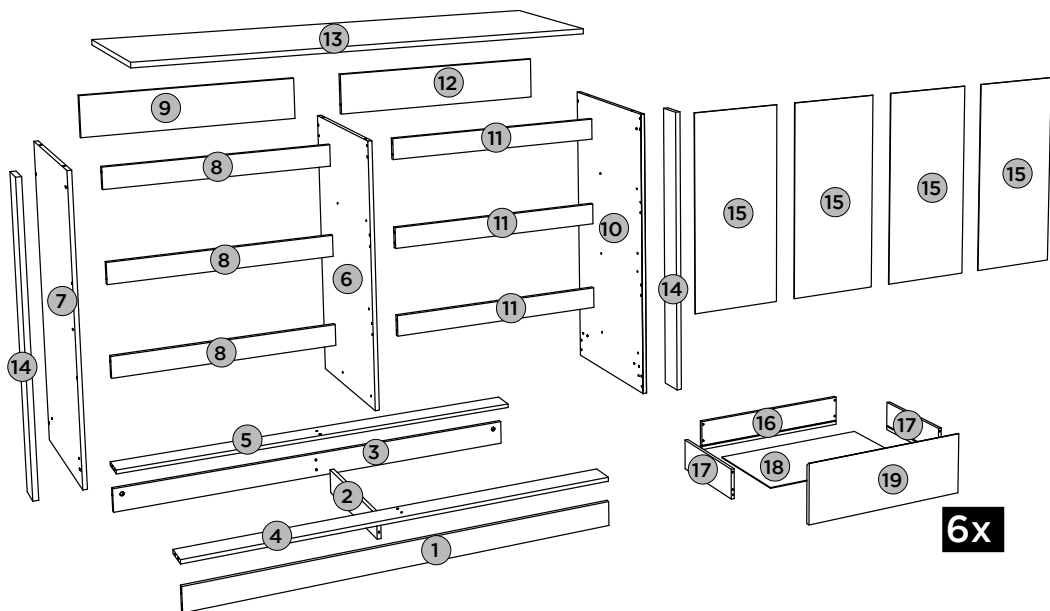

| Item | Caixa Caja Box | Qty Ctd Qty | Descrição Descripción Description | Dimensões (mm) Dimensiones (mm) Dimensions (mm) | | |
|-------|----------------------|-------------------|---|--|---------------------------|---------------------------------|
| | | | | Comprimento Largo Length | Largura Ancho Width | Espesura Grosor Thickness |
| 1 | 1/1 | 1 | RODAPÉ FRONTAL PIE DE PÁGINA FRONTAL FRONT FOOTER | 1240 | 73 | 12 |
| 2 | 1/1 | 1 | TRAVESSA DO RODAPÉ TRAVESAÑO DE PIE DE PÁGINA FOOTER CROSSPIECE | 425 | 73 | 12 |
| 3 | 1/1 | 1 | RODAPÉ TRASEIRO ZÓCALO TRASERO REAR FOOTER | 1240 | 73 | 12 |
| 4 | 1/1 | 1 | TRAVESSA BASE FRONTAL TRAVESAÑO DE LA BASE DELAN- TERA FRONT BASE CROSSPIECE | 1240 | 80 | 12 |
| 5 | 1/1 | 1 | TRAVESSA BASE TRASEIRA TRAVESAÑO BASE TRASERO REAR BASE CROSS MEMBER | 1240 | 80 | 12 |
| 6 | 1/1 | 1 | DIVISÃO DIVISIÓN DIVISION | 780 | 455 | 12 |
| 7 | 1/1 | 1 | LATERAL ESQUERDA LATERAL IZQUIERDA LEFT SIDE | 865 | 455 | 12 |
| 8=11 | 1/1 | 6 | TRAVESSA GAVETA BANDEJA DEL CAJÓN DRAWER TRAY | 614 | 60 | 12 |
| 9=12 | 1/1 | 2 | TRAVESSA TRASEIRA MAIOR TRAVESAÑO TRASERO MÁS GRANDE LARGE REAR CROSS MEMBER | 614 | 120 | 12 |
| 10 | 1/1 | 1 | LATERAL DIREITA LATERAL DERECHA RIGHT SIDE | 865 | 455 | 12 |
| 11=9 | 1/1 | 6 | TRAVESSA GAVETA BANDEJA DEL CAJÓN DRAWER TRAY | 614 | 60 | 12 |
| 12=10 | 1/1 | 2 | TRAVESSA TRASEIRA MAIOR TRAVESAÑO TRASERO MÁS GRANDE LARGE REAR CROSS MEMBER | 614 | 120 | 12 |
| 13 | 1/1 | 1 | TAMPO CUBRIR COVER | 1296 | 475 | 15 |
| 14 | 1/1 | 2 | MOLDURA LATERAL MARCO LATERAL SIDE FRAME | 865 | 80 | 15 |
| 15 | 1/1 | 4 | FUNDO CRU FONDO CRUDO RAW BACKGROUND | 681 | 313 | 3 |
| 16 | 1/1 | 6 | RIPA DE TRÁS TABILLA TRASERA BACK CLAPBOARD | 594 | 110 | 12 |
| 17 | 1/1 | 12 | LADO DE GAVETA LADO DEL CAJÓN DRAWER SIDE | 350 | 110 | 12 |
| 18 | 1/1 | 6 | FUNDO DE GAVETA FONDO DEL CAJÓN DRAWER BOTTOM | 581 | 361 | 3 |
| 19 | 1/1 | 6 | FRENTE DE GAVETA FRENTE DEL CAJÓN DRAWER FRONT | 622 | 220 | 15 |

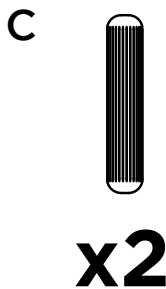
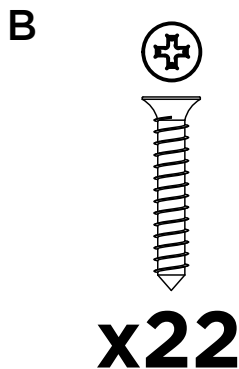
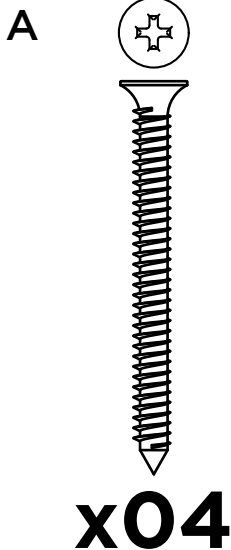

LISTA DE PEÇAS | LISTA DE PIEZAS | LIST OF PIECES

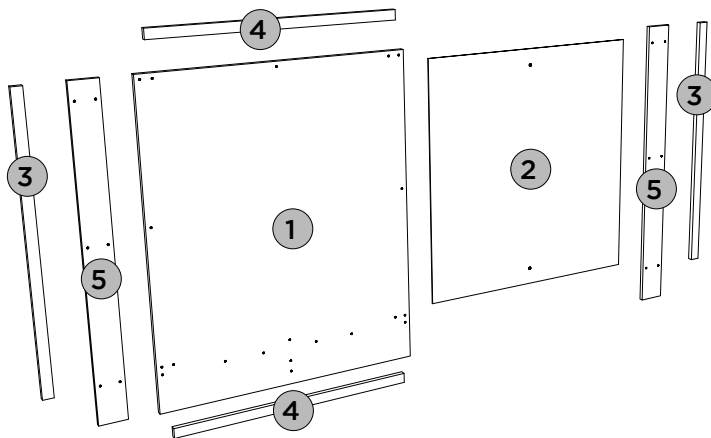

| Item | Caixa Caja Box | Qtd Ctd Qty | Descrição Descripción Description | Dimensões (mm) Dimensiones (mm) Dimensions (mm) | | |
|------|----------------------|-------------------|--|---|---------------------------|----------------------------------|
| | | | | Comprimento Largo Length | Largura Ancho Width | Espessura Grosor Thickness |
| 1 | 1/1 | 01 | FUNDO ESPELHO FONDO DEL ESPEJO MIRROR BACKGROUND | 937 | 766 | 15 |
| 2 | 1/1 | 01 | ESPELHO ESPEJO MIRROR | 750 | 700 | 3 |
| 3 | 1/1 | 02 | TRAVESSA LATERAL TRAVESAÑO LATERAL SIDE CROSSPIECE | 817 | 766 | 15 |
| 4 | 1/1 | 02 | TRAVESSA INFERIOR SUPERIOR TRAVESAÑO INFERIOR SUPERIOR UPPER BOTTOM CROSSPIECE | 706 | 30 | 15 |
| 5 | 1/1 | 02 | TRAVESSA ESTRUTURAL TRAVESAÑO ESTRUCTURAL STRUCTURAL CROSSPIECE | 934 | 80 | 12 |





PASSO 1

ITM/D737-

PEÇAS REQUERIDAS

| | | |
|---|------------------------|----|
| 1 | RODAPÉ FRONTAL | x1 |
| 2 | TRAVESSA DO RODAPÉ | x1 |
| 3 | RODAPÉ TRASEIRO | x1 |
| 4 | TRAVESSA BASE FRONTAL | x1 |
| 5 | TRAVESSA BASE TRASEIRA | x1 |

ACESSÓRIOS REQUERIDOS

| | | |
|---|---|----|
| D |  | 02 |
| G |  | 12 |
| K |  | 02 |
| M |  | 08 |

FERRAMENTAS NECESSÁRIAS

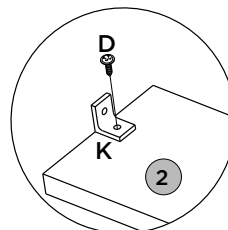
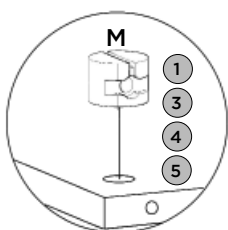
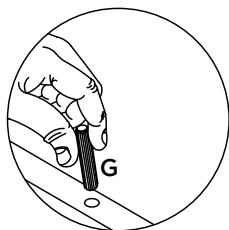
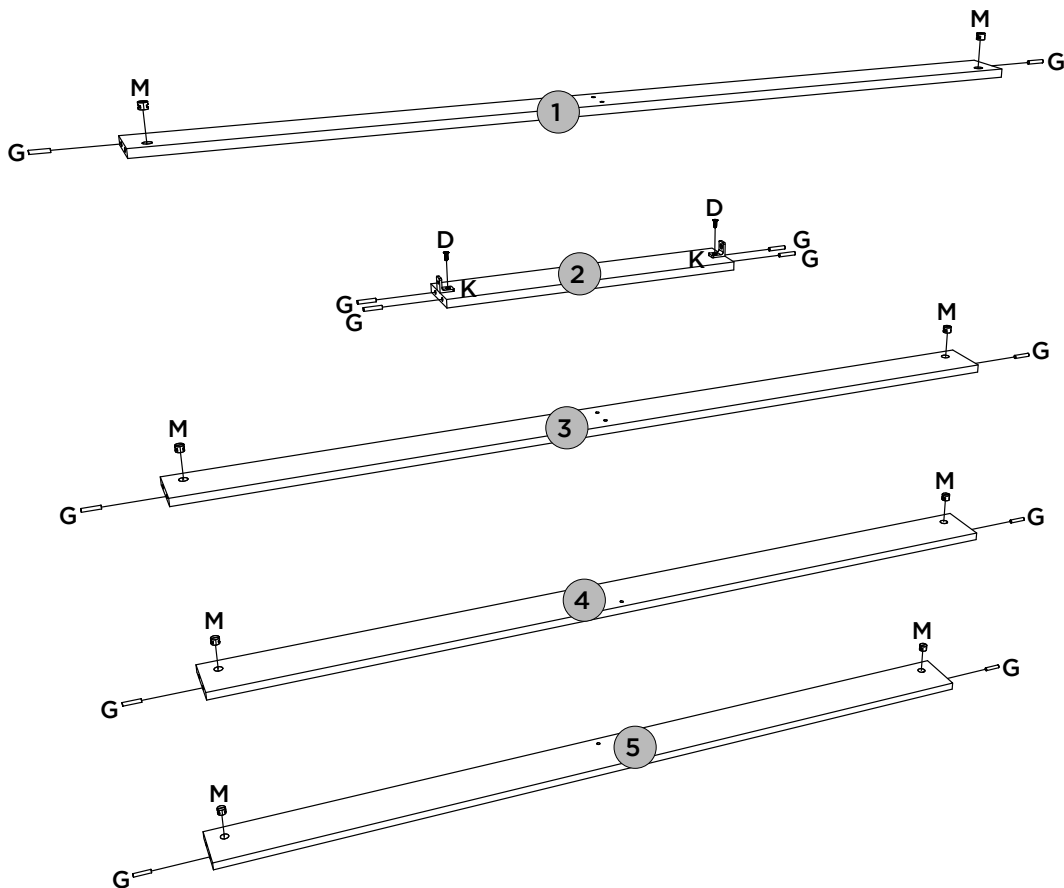
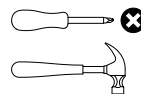



PASSO 2

ITM/D737-

PEÇAS REQUERIDAS

| | | |
|------|-------------------------|----|
| 6 | DIVISÃO | x1 |
| 7 | LATERAL ESQUERDA | x1 |
| 8=11 | TRAVESSA GAVETA | x6 |
| 9=12 | TRAVESSA TRASEIRA MAIOR | x2 |
| 10 | LATERAL DIREITA | x1 |

ACESSÓRIOS REQUERIDOS

| | | |
|---|---|----|
| E |  | 36 |
| G |  | 32 |
| N |  | 06 |

FERRAMENTAS NECESSÁRIAS

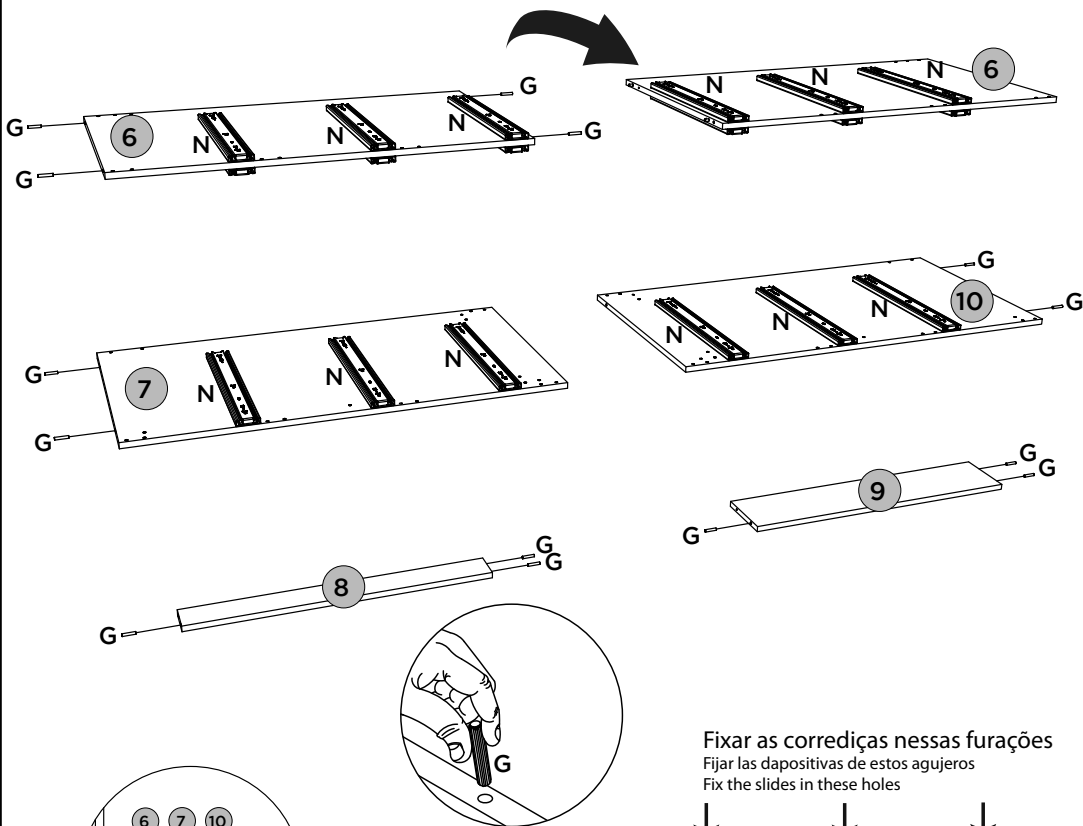
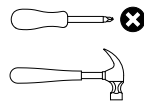

Fixar as corrediças nessas furações
 Fijar las dapositivas de estos agujeros
 Fix the slides in these holes

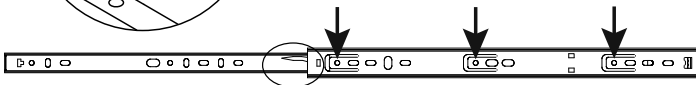

Para a desmontagem da corrediça, siga a instrução ao lado

Para el desmontaje de la diapositiva, siga las instrucciones en el lado

For disassembly of the slide, follow the instruction on the side

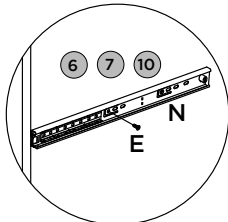
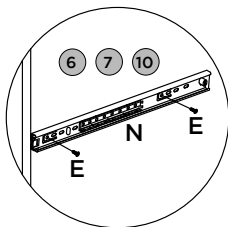
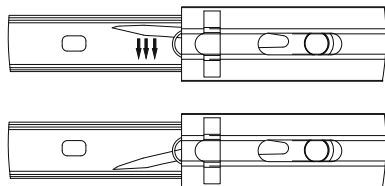

PASSO 3

ITM/D737-

PEÇAS REQUERIDAS

| | | |
|---|--------------------|----|
| 1 | RODAPÉ FRONTAL | x1 |
| 2 | TRAVESSA DO RODAPÉ | x1 |
| 3 | RODAPÉ TRASEIRO | x1 |

ACESSÓRIOS REQUERIDOS



FERRAMENTAS NECESSÁRIAS

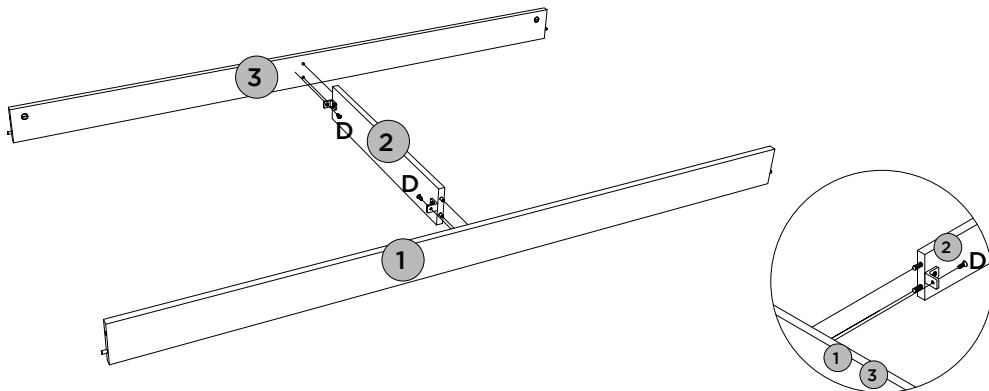
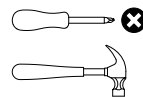

PASSO 4

PEÇAS REQUERIDAS

| | | |
|---|------------------------|----|
| 4 | TRAVESSA BASE FRONTAL | x1 |
| 5 | TRAVESSA BASE TRASEIRA | x1 |
| 6 | DIVISÃO | x1 |

ACESSÓRIOS REQUERIDOS

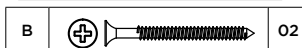



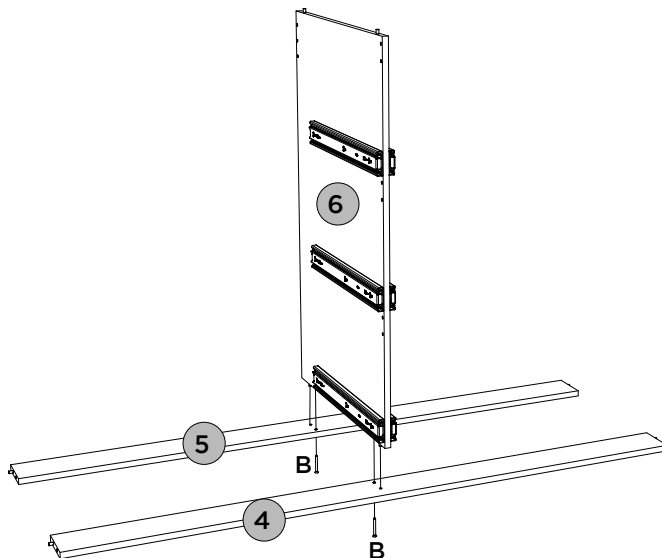
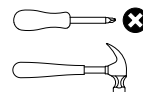

FERRAMENTAS NECESSÁRIAS



PASSO 5**PEÇAS REQUERIDAS**

| | | |
|---|-------------------------|----|
| 7 | LATERAL ESQUERDA | x1 |
| 8 | TRAVESSA GAVETA | x3 |
| 9 | TRAVESSA TRASEIRA MAIOR | x1 |

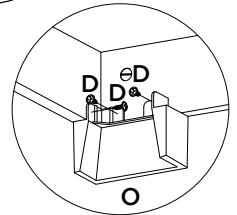
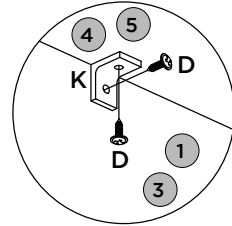
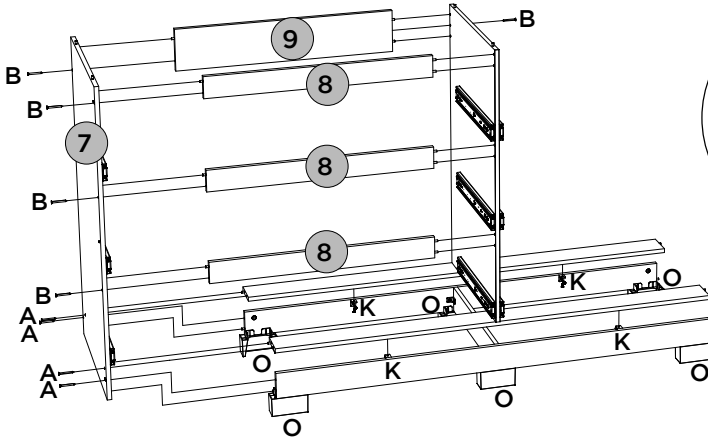
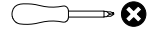

ACESSÓRIOS REQUERIDOS

| | | |
|---|---|----|
| A |  | 04 |
| B |  | 05 |
| D |  | 26 |
| K |  | 04 |
| O |  | 06 |

FERRAMENTAS NECESSÁRIAS**PASSO 6****PEÇAS REQUERIDAS**

| | | |
|----|-------------------------|----|
| 10 | LATERAL DIREITA | x1 |
| 11 | TRAVESSA GAVETA | x3 |
| 12 | TRAVESSA TRASEIRA MAIOR | x1 |

ACESSÓRIOS REQUERIDOS

| | | |
|---|---|----|
| A |  | 04 |
| B |  | 04 |

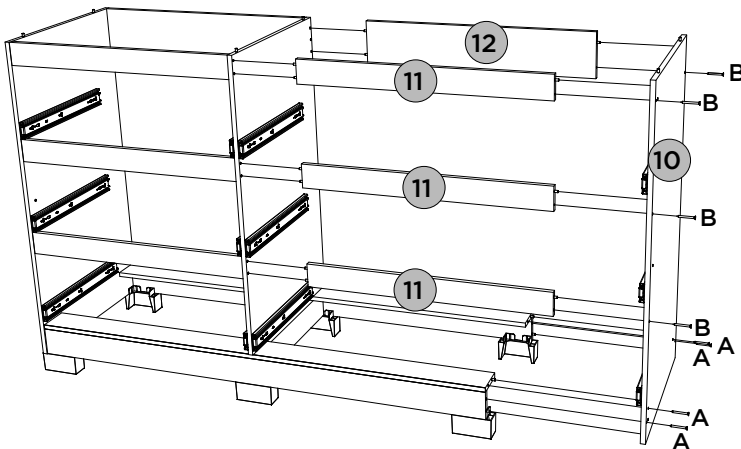
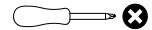
FERRAMENTAS NECESSÁRIAS

PASSO 7

ITM/D737-

PEÇAS REQUERIDAS

| | | |
|----|-------|----|
| 13 | TAMPO | x1 |
|----|-------|----|

ACESSÓRIOS REQUERIDOS KIT

| | | |
|---|---|----|
| C |  | x2 |
| D |  | x4 |

FERRAMENTAS NECESSÁRIAS

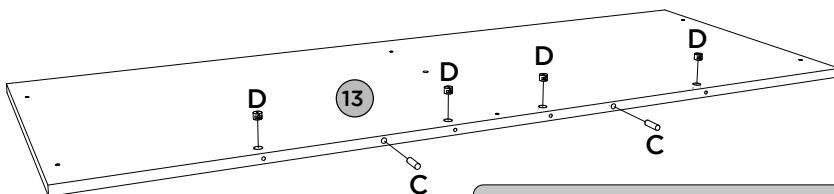
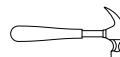

Se o Kit (O967-64) for adquirido, é necessário inserir a porca cilíndrica (D) e a cavilha (C) no Tampo (13) antes de ser fixado ao produto.

Si se compra el Kit (O967-64), es necesario insertar la tuerca cilíndrica (D) y el pasador (C) en la Tapa (13) antes de fijarla al producto.



If the Kit (O967-64) is purchased, it is necessary to insert the cylindrical nut (D) and the pin (C) in the Cover (13) before fixing it to the product.

PASSO 8

PEÇAS REQUERIDAS

| | | |
|----|-----------------|----|
| 13 | TAMPO | x1 |
| 14 | MOLDURA LATERAL | x2 |

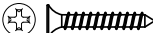
ACESSÓRIOS REQUERIDOS

| | | |
|---|---|----|
| C |  | 06 |
| D |  | 10 |
| K |  | 05 |

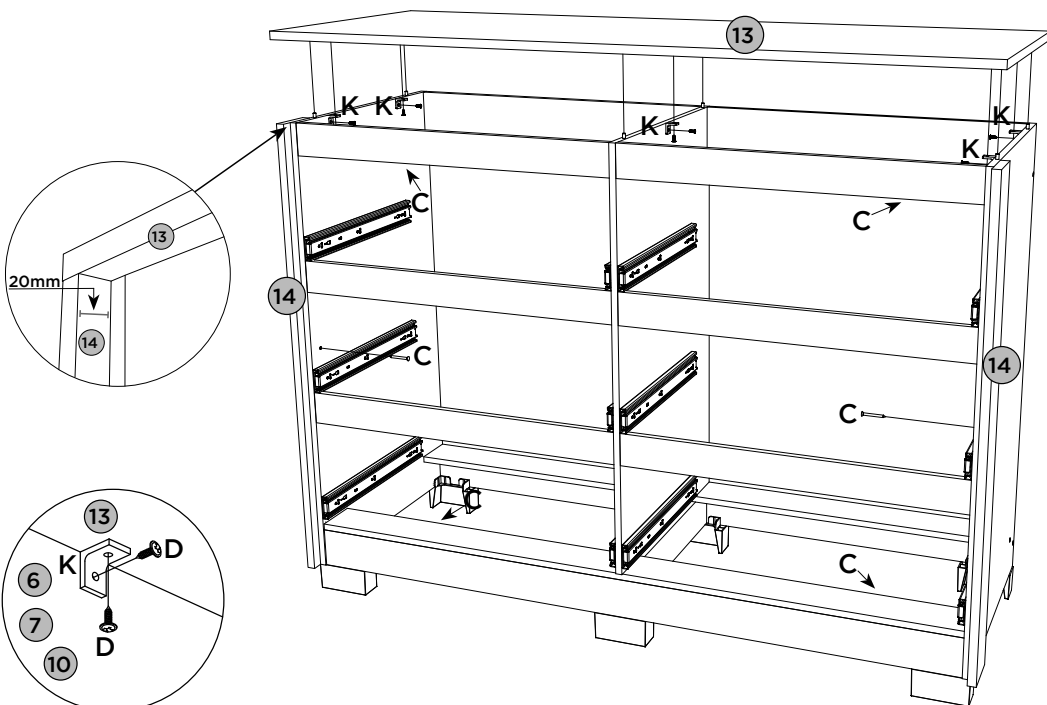
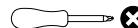

FERRAMENTAS NECESSÁRIAS



PEÇAS REQUERIDAS

| | | |
|----|-------|----|
| 15 | FUNDO | x4 |
|----|-------|----|

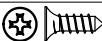
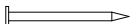
ACESSÓRIOS REQUERIDOS

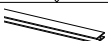
| | | |
|---|---|----|
| E |  | 12 |
| I |  | 26 |
| J |  | 06 |
| P |  | 02 |

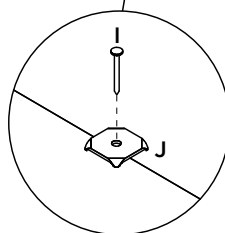
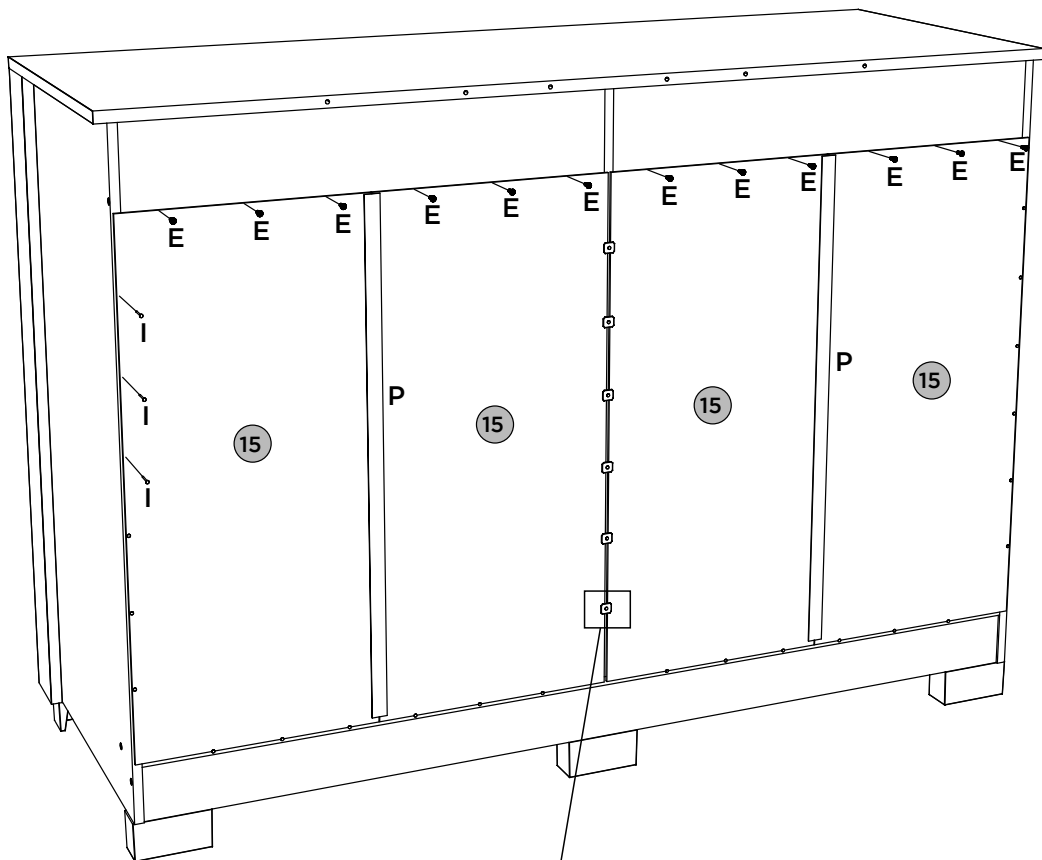
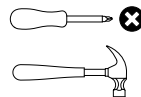
FERRAMENTAS NECESSÁRIAS

Fixar os pregos a uma distância de 100mm de um para outro.

Fijar las uñas a un distancia de 100mm uno a otro.

Fix the nails at a distance of 100mm from one to the other

PASSO 10

ITM/D737-

PEÇAS REQUERIDAS

| | | |
|----|----------------|-----|
| 17 | LADO DE GAVETA | x12 |
|----|----------------|-----|

ACESSÓRIOS REQUERIDOS

| | | |
|---|---|----|
| G |  | 48 |
| Q |  | |

FERRAMENTAS NECESSÁRIAS

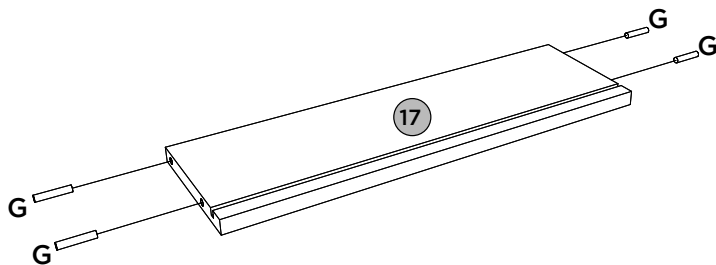



PASSO 11

PEÇAS REQUERIDAS

| | | |
|----|-----------------|-----|
| 16 | RIPA DE TRÁS | x6 |
| 17 | LADO DE GAVETA | x12 |
| 18 | FUNDO DE GAVETA | x6 |

ACESSÓRIOS REQUERIDOS

| | | |
|---|---|----|
| H |  | 12 |
| Q |  | |

FERRAMENTAS NECESSÁRIAS

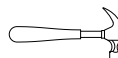

6x

1º

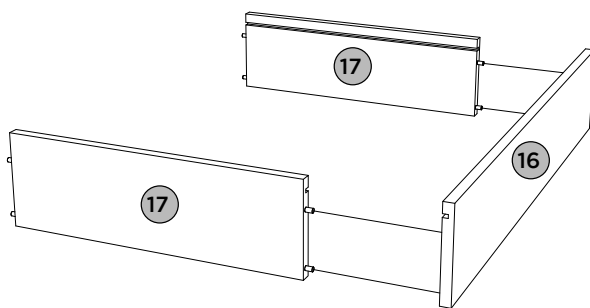

6x

2º

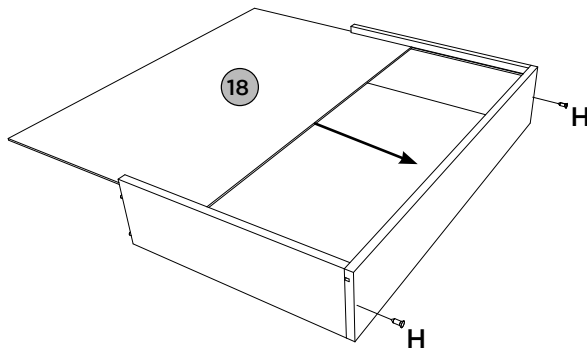
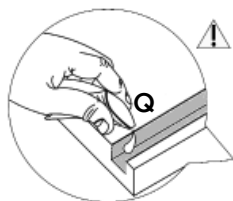

PASSO 12

ITM/D737-

PEÇAS REQUERIDAS

| | | |
|----|------------------|----|
| 19 | FRENTE DE GAVETA | x6 |
|----|------------------|----|

ACESSÓRIOS REQUERIDOS

| | | |
|---|--|----|
| E | | 60 |
| F | | 12 |
| K | | 12 |
| L | | 12 |
| N | | 06 |
| Q | | |

FERRAMENTAS NECESSÁRIAS

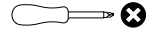

6x

3º

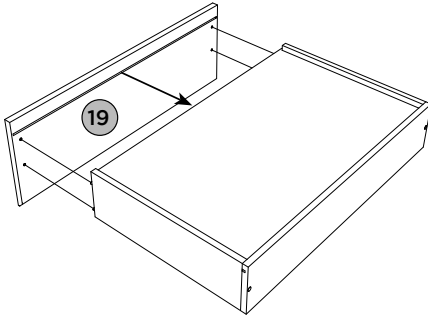

6x

4º

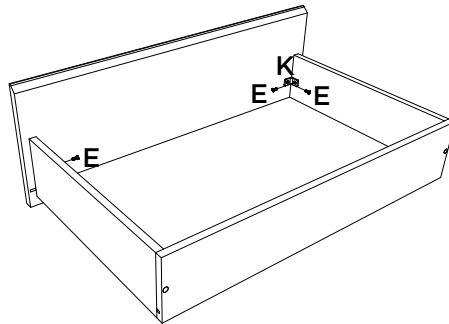
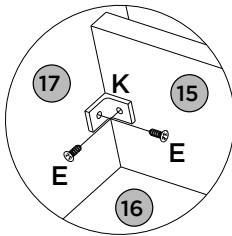

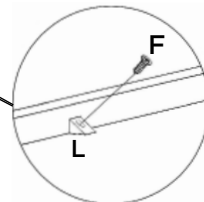
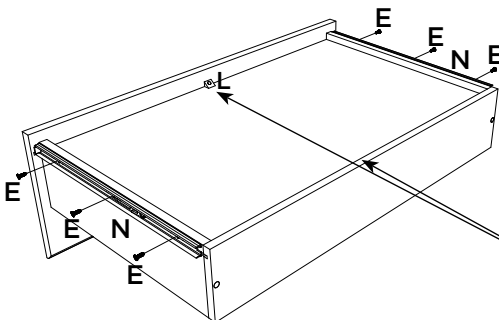

6x

5º



ACESSÓRIOS REQUERIDOS

| | | |
|---|---|----|
| R |  | 06 |
| S |  | 02 |
| T | HENN | 01 |

Pesos máximos recomendados com carga distribuída
 Peso máximo recomendado con la carga distribuida
 Recommended maximum weight with distributed load.

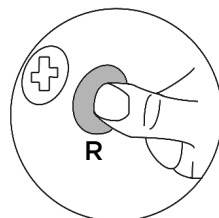
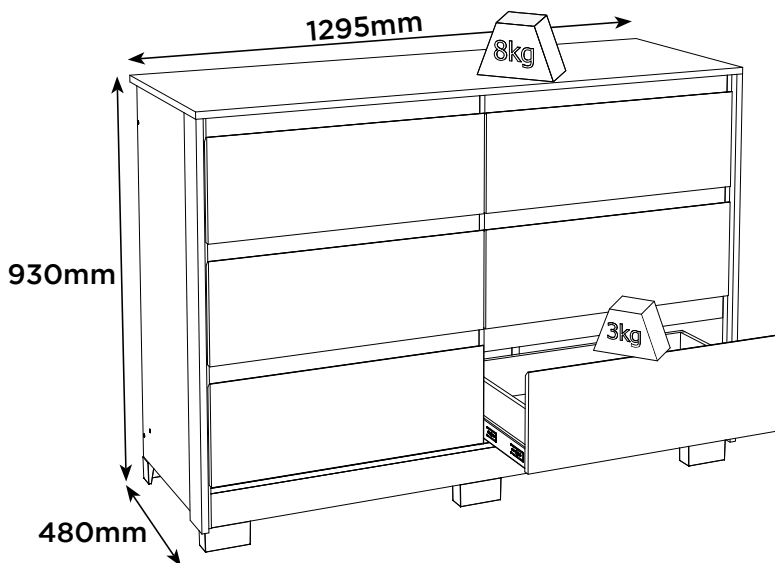

PERFECT CORRECTION
 CORRECCIÓN PERFECTA

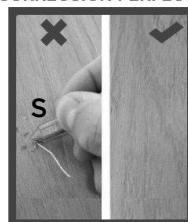

Produto Concluído
 Producto terminado
 Finished Product

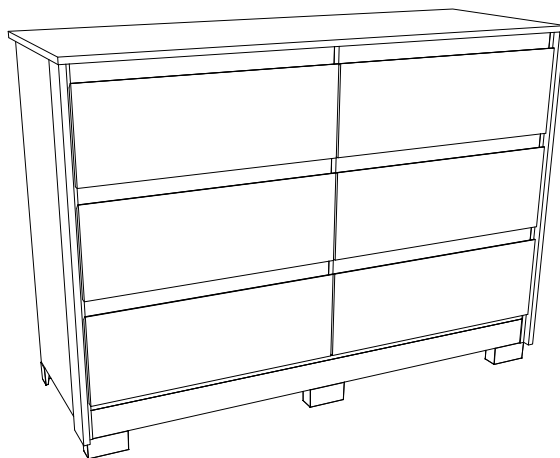

PASSO 14

ITM/D737-

PEÇAS REQUERIDAS

| | | |
|---|----------------------------|----|
| 1 | FUNDO ESPELHO | x1 |
| 2 | ESPELHO | x1 |
| 3 | TRAVESSA LATERAL | x2 |
| 4 | TRAVESSA INFERIOR SUPERIOR | x2 |

ACESSÓRIOS REQUERIDOS KIT

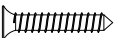
| | | | |
|---|---|---|----|
| B |  |  | 12 |
|---|---|---|----|

FERRAMENTAS NECESSÁRIAS

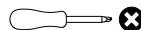

Esse Kit Espelho é opcional e é vendido separadamente (O967-64).

Este juego de espejos es opcional y se vende por separado (O967-64).

This Mirror Kit is optional and sold separately (O967-64).

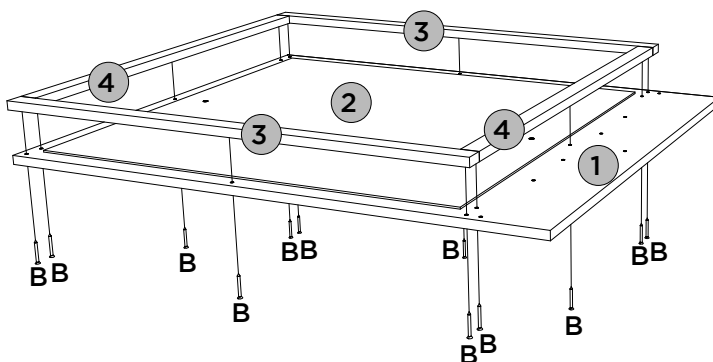

PASSO 15

PEÇAS REQUERIDAS

| | | |
|---|---------------------|----|
| 5 | TRAVESSA ESTRUTURAL | x2 |
|---|---------------------|----|

ACESSÓRIOS REQUERIDOS KIT

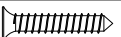
| | | | |
|---|--|--|----|
| B |  |  | 10 |
|---|--|--|----|

FERRAMENTAS NECESSÁRIAS

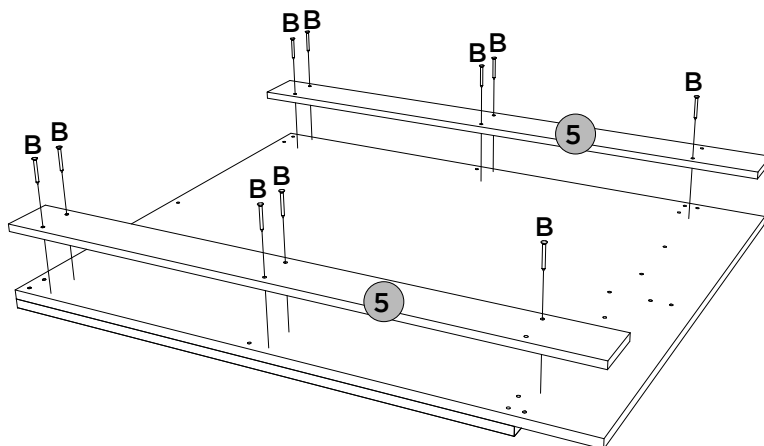

ACESSÓRIOS REQUERIDOS KIT

FERRAMENTAS NECESSÁRIAS

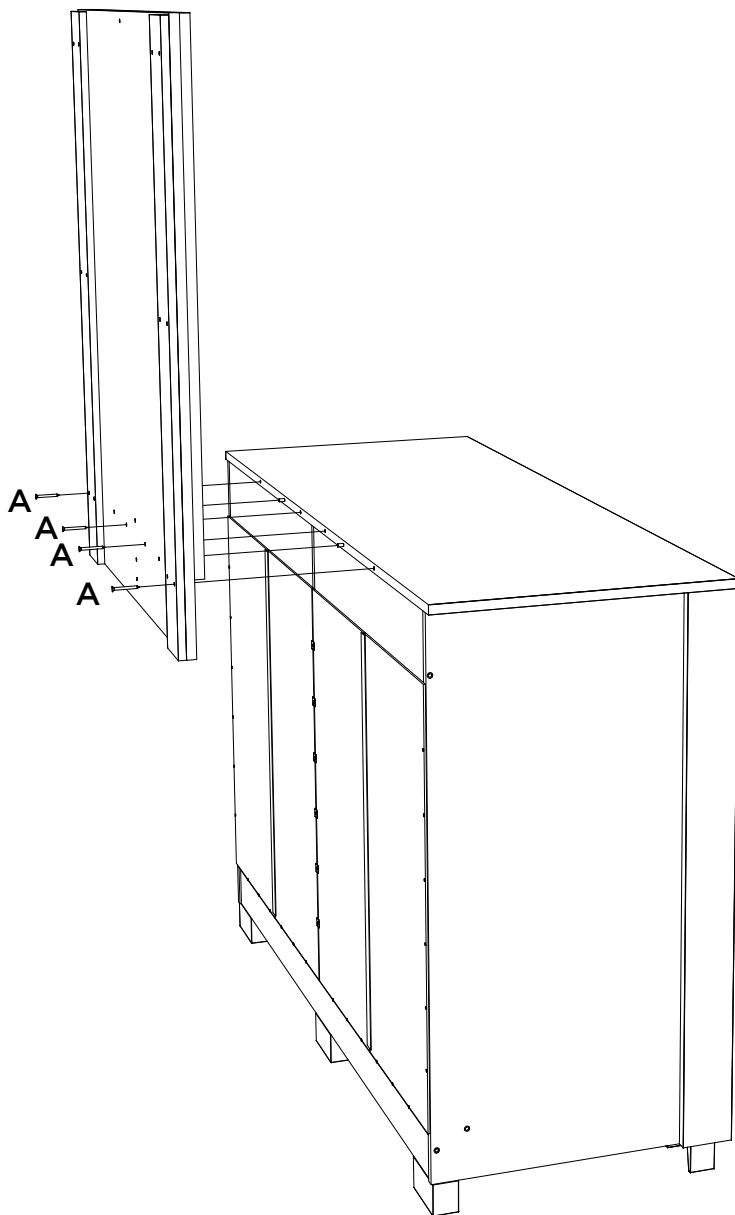
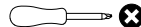
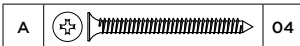

Produto Concluído
Producto terminado
Finished Product

