

# CO9510 - COZINHA

Manual de Montagem  
 Assembly Instructions  
 Instrucción de Montaje

decibal<sup>®</sup>  
 móveis

Produto Montado  
 Producto final  
 Assembled

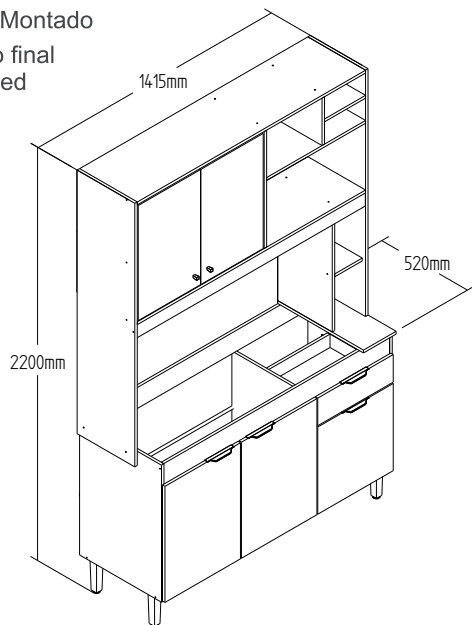

1º

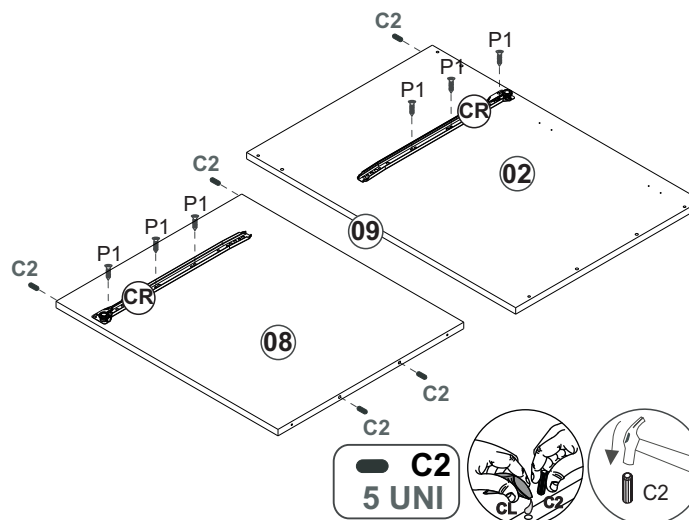
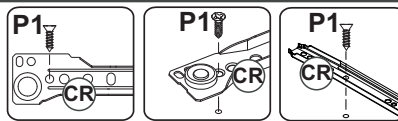

2º

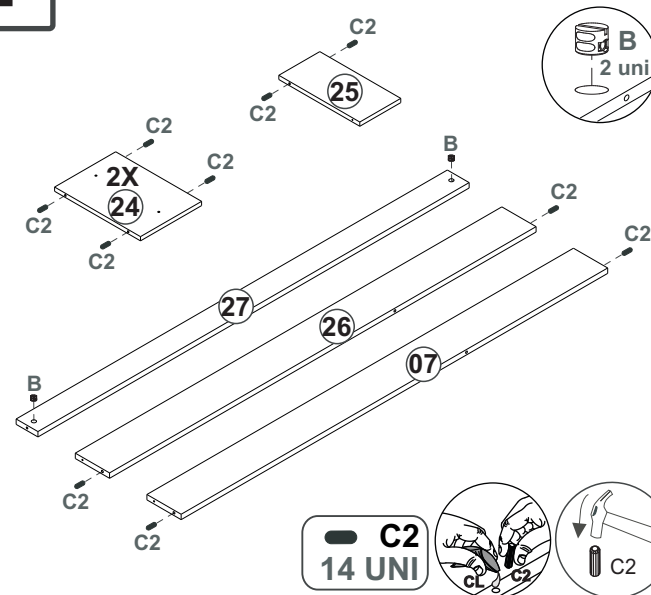

3º

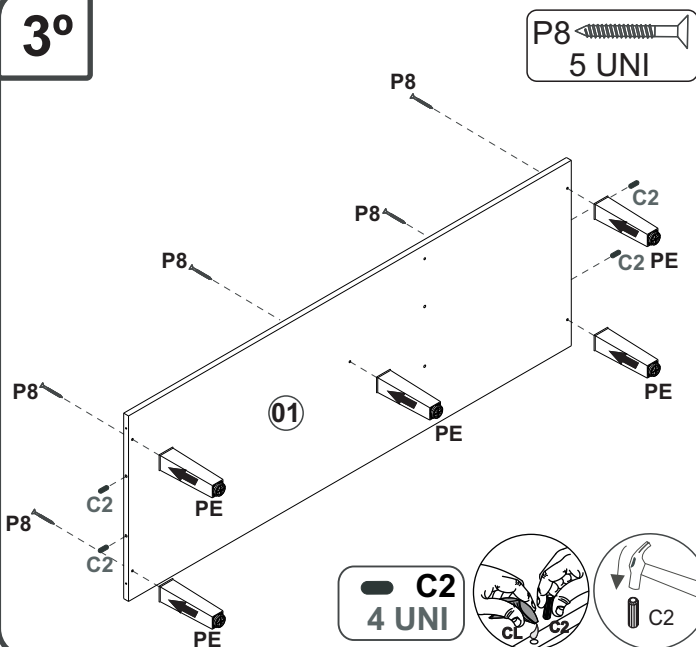

4º

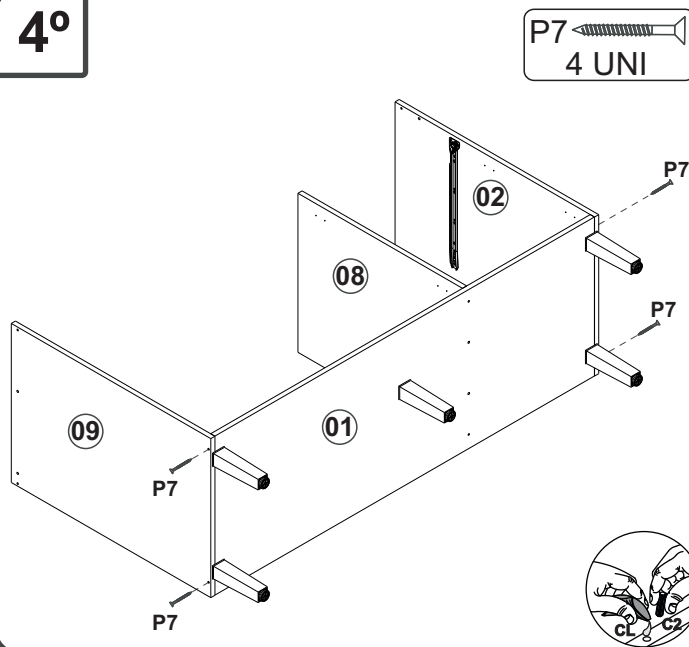

5º

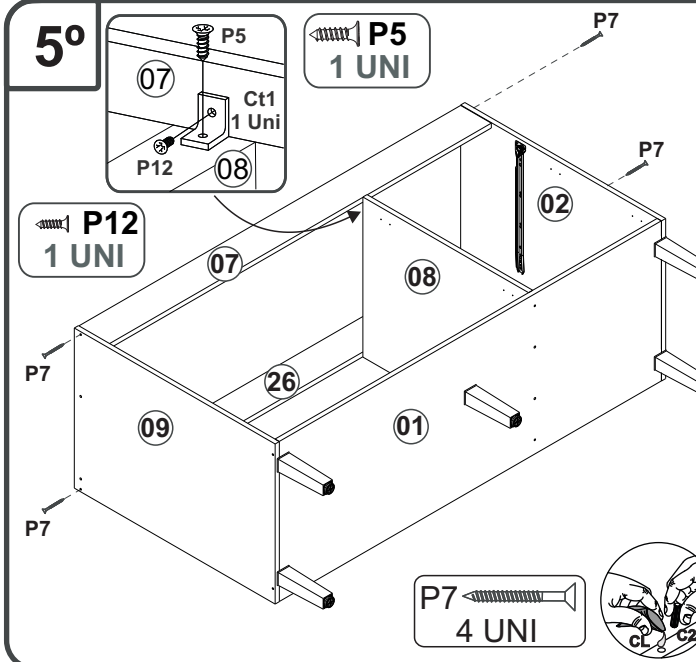



# CO9510 - COZINHA

Manual de Montagem  
 Assembly Instructions  
 Instrucción de Montaje



12°

COSTA/REVÉS/BACK

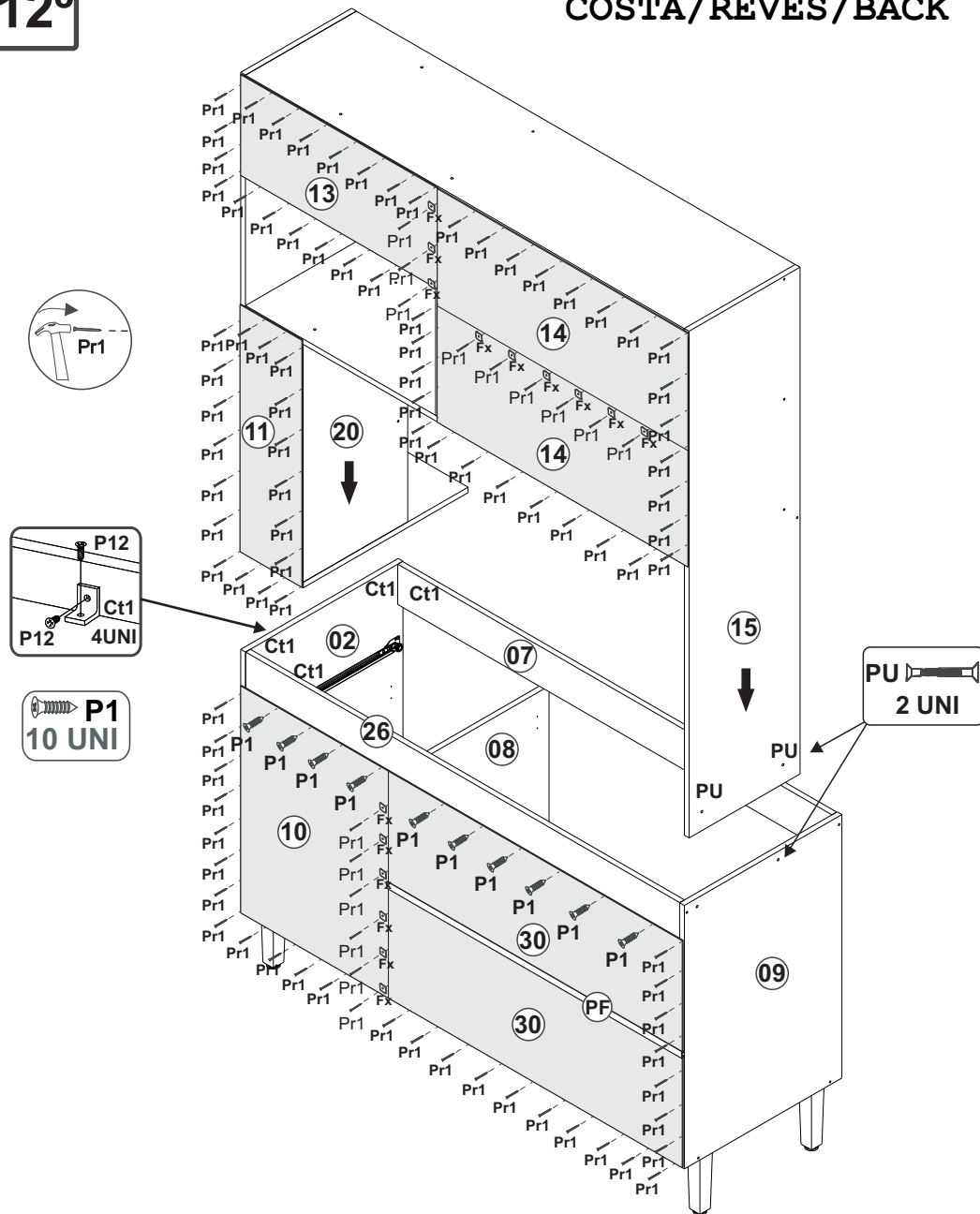

13°

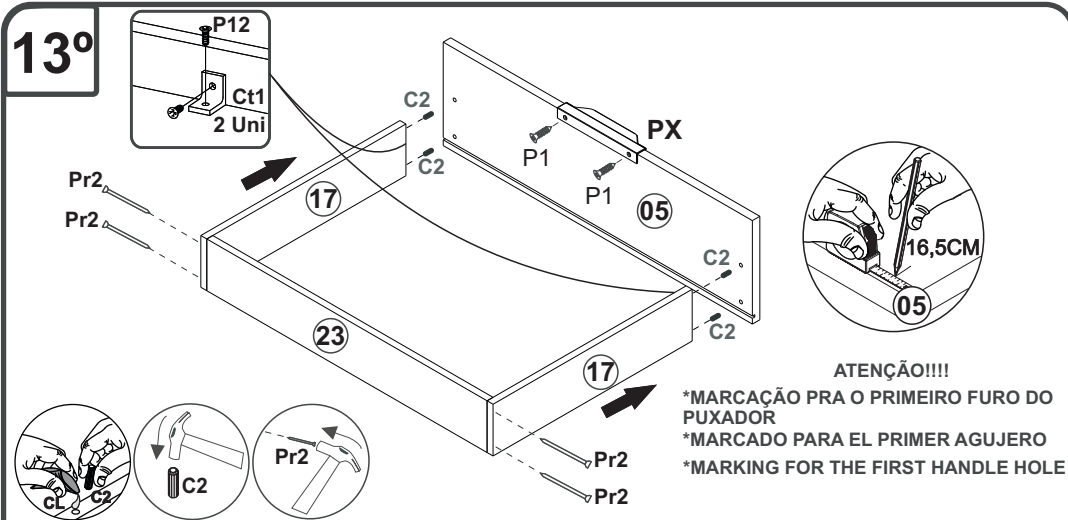

ATENÇÃO!!!!  
 \*MARCAÇÃO PRA O PRIMEIRO FURO DO PUXADOR  
 \*MARCADO PARA EL PRIMER AGUJERO  
 \*MARKING FOR THE FIRST HANDLE HOLE

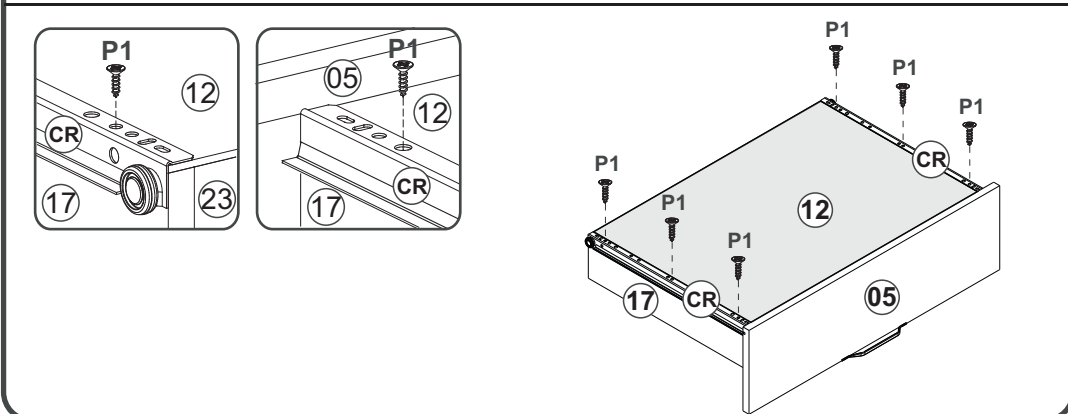
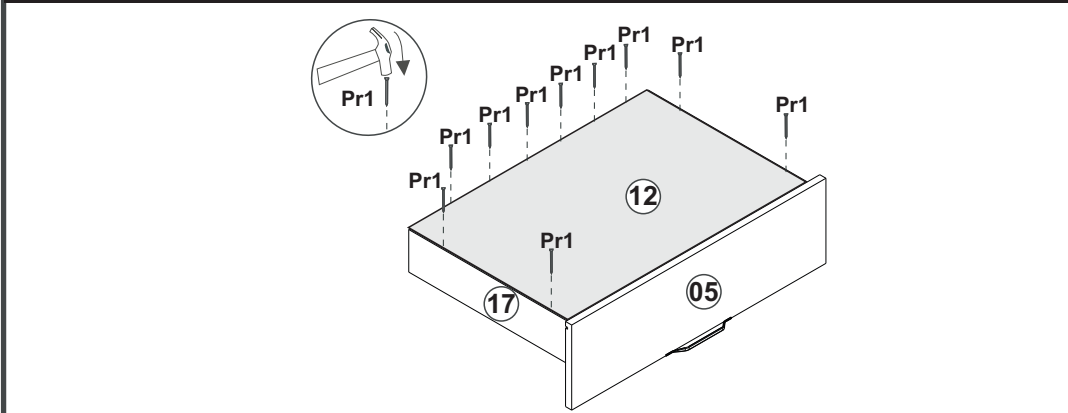

# CO9510 - COZINHA

Manual de Montagem  
 Assembly Instructions  
 Instrucción de Montaje

decibal<sup>®</sup>  
 móveis

14°

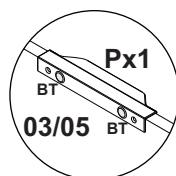
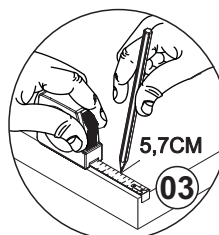
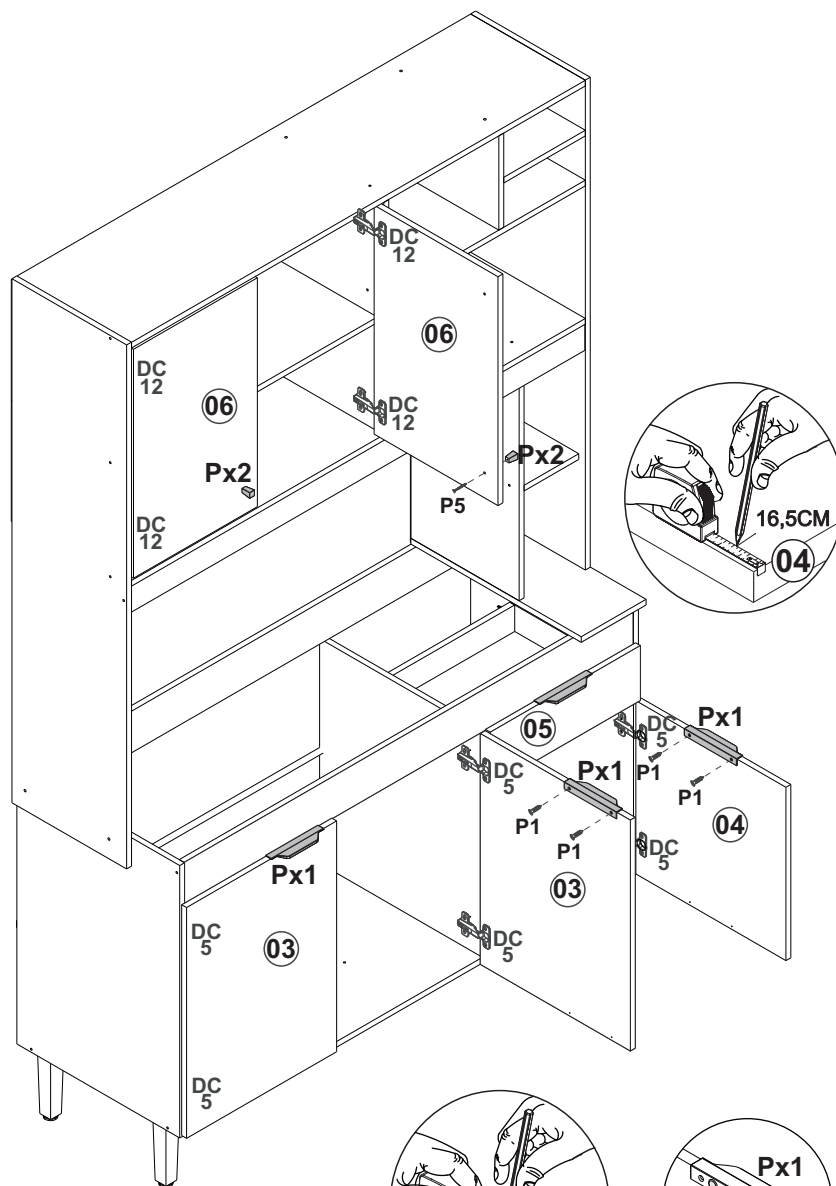
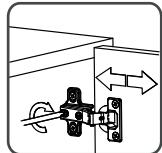
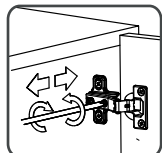
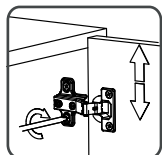
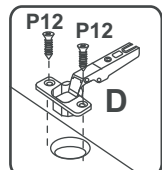
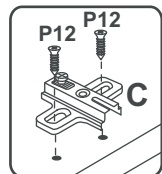

ATENÇÃO!!!!

MARCAÇÃO PRA O PRIMEIRO FURO DO PUXADOR  
 MARCADO PARA EL PRIMER AGUJERO  
 MARKING FOR THE FIRST HANDLE HOLE

PESO SUPORTADO/PESO SOPORTADO/ WEIGHT SUPPORTED

Fixação na parede / Fijación a la pared / Wall fixing

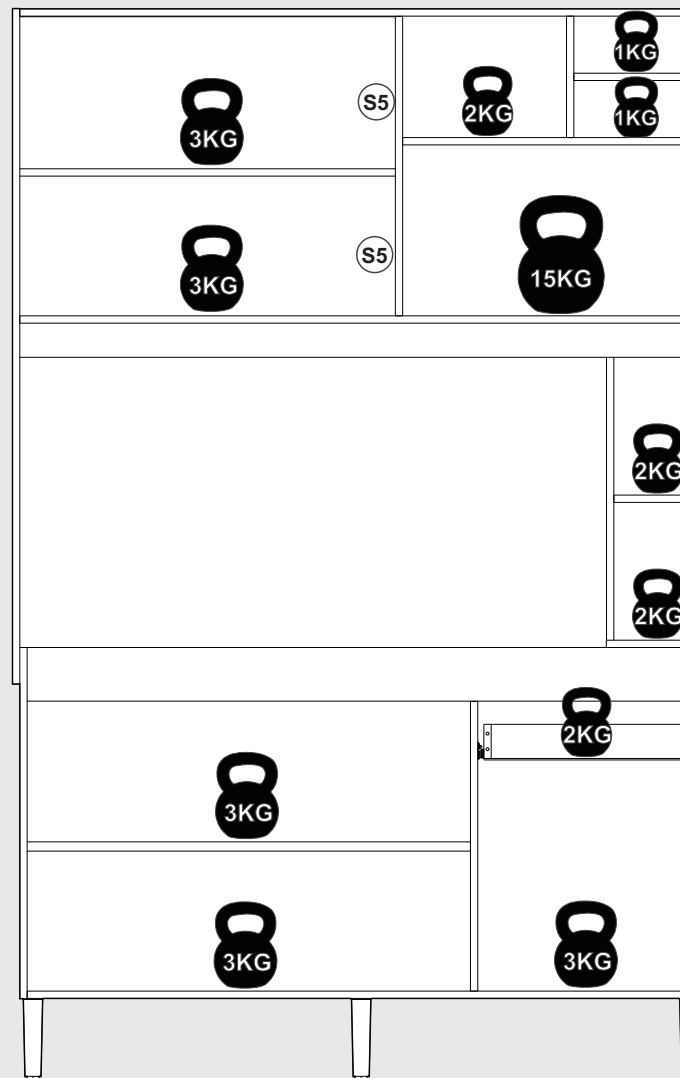
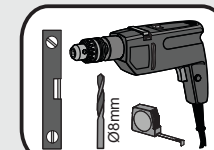
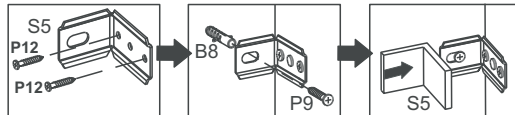

[www.decibal.com.br](http://www.decibal.com.br)

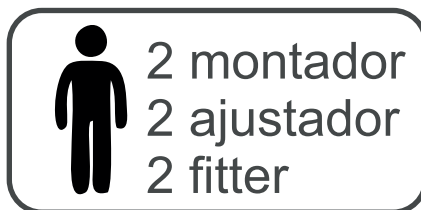
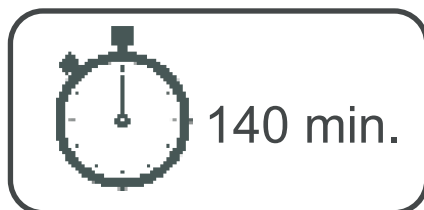

ATENÇÃO!!!! montadores e consumidores

\* Ajustar o torque da parafusadeira para não danificar as peças escareando o parafuso \*

ATENCIÓN!!!! montadores e consumidores

\* Ajuste el torque del destornillador para no dañar las piezas avallanando el tornillo \*

ATTENTION!!!! assemblers and consumers

\* Adjust the torque of the screwdriver so as not to damage the parts by countersinking the screw \*

Ferramentas necessárias  
Necessary tools  
Herramientas necesarias

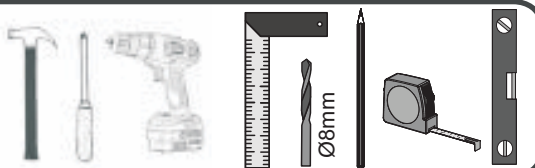

## Relação de Peças/ Relación de Piezas/Parts List

Nº	CÓDIGO/CODE	DESCRIÇÃO/DESCRIPCIÓN/DESCRIPTION	QTD/CANT	VOL
1	0551225	BASE INF 1370X497X15 MM	1,00	01
2	0551226	LATERAL DIR INF/LATERAL/SIDE 720X497X15 MM	1,00	01
3	0551231	PORTA INF MAIOR/PUERTA/DOOR 610X458X15 MM	2,00	01
4	0551232	PORTA INF MENOR/PUERTA/DOOR 458X458X15 MM	1,00	01
5	0551233	FRENTE DE GAVETA/FRENTECAJON/DRAWER FRONT 458X145X15 MM	1,00	01
6	0551244	PORTA SUP/PUERTA/DOOR 605X378X15 MM	2,00	01
7	0551228	TRAVESSA FRT/TRAVIESSA/TRVERSE 1370X1100X15 MM	1,00	01
8	0551230	DIV INF/DIVIDER 594X497X15 MM	1,00	01
9	0551227	LATERAL ESQ/LATERAL/SIDE 680X497X12 MM	1,00	01
10	0551249	COSTA INF MENOR/REVÉS/BACK 624X466X2,8 MM	1,00	01
11	0551253	COSTA INT/REVÉS/BACK 675X193X2,8 MM	1,00	01
12	0551248	FUNDO DE GAVETA/FONDOCAJON/DRAWER BOTTON 420X355X2,8 MM	1,00	01
13	0551252	COSTA SUP MENOR/REVÉS/BACK 620X275X2,8 MM	1,00	01
14	0551251	COSTA SUP MAIOR/REVÉS/BACK 790X320X2,8 MM	2,00	01
15	0551238	LAT ESQ SUP /LATERAL/SIDE 1385X350X15 MM	1,00	02
16	0551237	LAT DIR SUP /LATERAL/SIDE 1295X350X15 MM	1,00	02
17	0551234	LAT GAV/LATERAL CAJÓN/DRAWER SIDE 350X70X15 MM	2,00	02
18	0551241	DIV SUP/DIVIDER 614X350X15 MM	1,00	02
19	0551243	PRAT SUP MENOR/ESTANTE/SHELF 600X350X15 MM	1,00	02
20	0551246	DIV MAIOR INF/DIVIDER 650X330X15 MM	1,00	02
21	0551242	PRAT SUP MAIOR/ESTANTE/SHELF 770X295X15 MM	1,00	02
22	0551236	TAMPO INF/TAPA/TOP 520X198X15 MM	1,00	02
23	0551235	BATENTE/REVÉS CAJÓN/DRAWER BACK 391X70X15 MM	1,00	02
24	0551245	DIV SUP MENOR/DIVIDER 350X249X15 MM	2,00	02
25	0551247	PRAT INF/ESTANTE/SHELF 330X167X15 MM	1,00	02
26	0551229	TRAVESSA TRS/TRAVIESSA/TRVERSE 1370X110X15 MM	1,00	02
27	0551240	TRAVESSA SUP/TRAVIESSA/TRVERSE 1385X70X15 MM	1,00	02
28	0551239	BASE SUP 1385X350X15 MM	1,00	02
29	0560445	BASE INT 1385X350X15 MM	1,00	02
30	0561250	COSTA MAIOR INF/REVÉS/BACK 927X307X2,8 MM	2,00	02



# CO9510 - COZINHA

Manual de Montagem  
Assembly Instructions  
Instrucción de Montaje





**decibal**<sup>®</sup>  
móveis

## Ferragens/ Herrajes/ Hardware

escala (1:1)

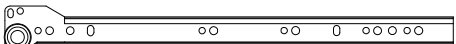
LEGENDA	DESCRIÇÃO/DESCRIPCIÓN/DESCRIPTION	CÓDIGO	QUANT.
<b>Pr2</b>	 PREGO/CLAVO/NAIL 13X15	01329	<b>04</b>
<b>P8</b>	 PARAFUSO/TORNILLO/SCREW 5X45	01320	<b>05</b>
<b>C3</b>	 CAVILHA/TARUGO/DOWEL 6X50 MM	01212	<b>01</b>

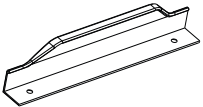
## Escala (N/A)

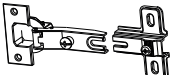
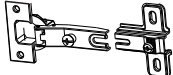
LEGENDA	DESCRIÇÃO/DESCRIPCIÓN/DESCRIPTION	CÓDIGO	QUANT.
<b>CR</b>	 CORREDICA/CORREDERA/METALIC SLIDE LARG 350 mm	01225	<b>01</b>
<b>PE</b>	 PÉ/PATA/FOOT (170MM) Champagne	12003	<b>05</b>
<b>Px1</b>	 PUXADOR/PEGADOR/HAND (PUX COVER TOPO 128MM ) CHAMPAGNE	11904	<b>04</b>
<b>Px2</b>	 PUXADOR/PEGADOR/HANDLE (PUX PONT REF 160) CHAMPAGNE	12199	<b>02</b>
<b>DC 12</b>	 DOBRADIÇA/BISAGRA/HINGE D=26mm C=12mm	01657	<b>04</b>
<b>DC 5</b>	 DOBRADIÇA/BISAGRA/HINGE D=26mm C=5mm	01268	<b>06</b>

**ATENÇÃO!!!! montadores e consumidores**

\* Para limpar o móveis utilize somente um pano úmido (umedecido em água pura ou água com sabão neutro). Depois, passe um pano seco.

Evite a umidade excessiva.

\* Evite usar álcool, água sanitária, detergente e outros produtos químicos, mesmo diluídos em água. Não utilize produtos abrasivos de nenhuma espécie

**ATENCIÓN!!!! montadores e consumidores**

\* Para limpiar el mueble utilice solamente un paño húmedo (humedecido con agua limpia o con un jabón suave).

A continuación, utilice un paño seco. Evite el exceso de humedad.

\* Evite uso de alcohol, hipocloridro solución basada, detergente y otros productos químicos, mismo diluidos en agua. No utilice productos abrasivos de ningún tipo.

**ATTENTION!!!! assemblers and consumers**

\*To clean the furniture, use only a damp cloth (humidify it only in pure water ou water and neutral soap). After, use a dry cloth. Avoid excessive humidity.

\*Avoid using alcohol, bleach, detergent and other chemical products, even diluted in water. Do not use any kind of abrasive cleaning agents to clean the furniture.

\*The use of such products may jeopardize the final characteristics of the furniture.

Medida em mm











# CO9510 - COZINHA











Manual de Montagem  
Assembly Instructions  
Instrucción de Montaje

**decibal**<sup>®</sup>  
móveis

## Ferragens/ Herrajes/ Hardware

		escala (1:1)	
LEGENDA	DESCRIÇÃO/DESCRIPCIÓN/DESCRIPTION	CÓDIGO	QUANT.
<b>P7</b>	 PARAFUSO/TORNILLO/SCREW 4X45	01318	<b>29</b>
<b>PR1</b>	 PREGO/CLAVO/NAIL 10X10	01330	<b>110</b>
<b>C2</b>	 CAVILHA/TARUGO/DOWEL 6X30 MM	01211	<b>41</b>
<b>P1</b>	 PARAFUSO/TORNILLO/SCREW 3,5X12	01328	<b>30</b>
<b>PU</b>	 PARAFUSO UNIÃO/UNIÓN DETORNILLO /SCREW UNION	01495	<b>02</b>
<b>P5</b>	 PARAFUSO/TORNILLO/SCRE3,5X25	03130	<b>03</b>
<b>P12</b>	 PARAFUSO/TORNILLO/SCREW 3,5X13	09927	<b>69</b>
<b>P9</b>	 PARAFUSO/TORNILLO/SCREW 6X50	03827	<b>02</b>

## escala (N/A)

LEGENDA	DESCRIÇÃO/DESCRIPCIÓN/DESCRIPTION	CÓDIGO	QUANT.
<b>CL</b>	 COLA/PEGAMENTO/GLUE	01213	<b>01</b>
<b>ET</b>	 ETIQUETA LOGO DECIBAL/LABEL DECIBAL	01312	<b>01</b>
<b>B8</b>	 BUCHA/BUJE/BUCHING	01311	<b>02</b>
<b>Ct1</b>	 CANTONEIRA/PIEZA L/SHEET	03077	<b>13</b>
<b>PF</b>	 PERFIL/PROFILE/PERFIL 920 MM	Wood/Brc 10278	<b>01</b>
<b>S5</b>	 SUPORTE AÉREO/APOYO AÉREO/AIR SUPPORT	03828 Wood 09647	<b>02</b>
<b>FX</b>	 FIXADOR COSTA/FIJADOR FONDO/FIXER COAST	01331	<b>14</b>
<b>B</b>	 BUCJA/BUJE/BUCHING	02734	<b>02</b>
<b>AD</b>	 ADESIVO/ADHESIVO/ADHESIVE 15mm	Wood 09929	<b>18</b>
<b>BT</b>	 BATENTE/BATIENTE DE SILICONA/SILICONE STOP 8MM	02921	<b>06</b>

Medida em mm

