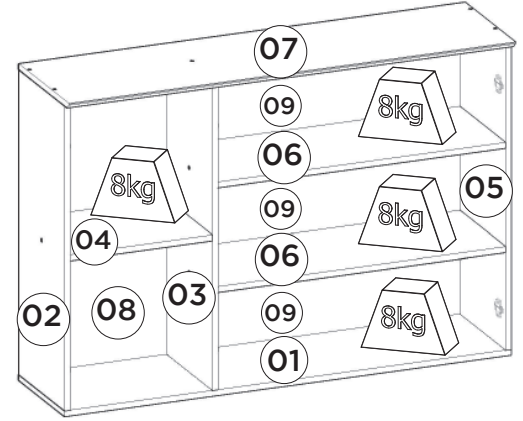
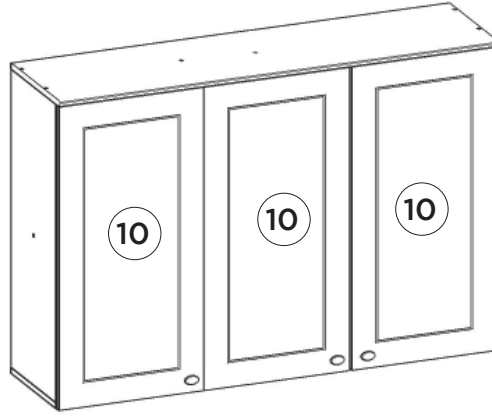
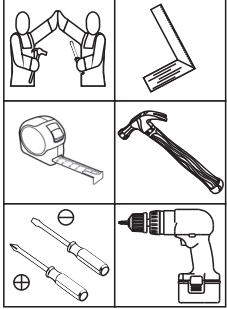

HENNInd. e Com. de Móveis Henn
Mondai - SC - Brasil

☎ +55 49 3674.3500

📷 @moveishenn
www.henn.com.br**INSTRUÇÕES DE MONTAGEM****INSTRUCCIONES DE MONTAJE
ASSEMBLY INSTRUCTIONS****Cozinha Compacta Americana 4 peças com Torre Quente**Referência/Cor
CE373-05 Branco HPRequisitos para montagem
Requisitos para la montaje
Assembly RequirementsImagens meramente ilustrativas
Imágenes meramente ilustrativas
Images for illustration only**Pesos máximos recomendados com carga distribuída
Peso máximo recomendado con la carga distribuida
Recommended maximum weight with distributed load.****Lista de Peças | Lista de piezas | List of parts**

Item	Caixa Caja Box	Qtd Ctd Qty	Descrição Descripción Description	Medidas (mm) Dimensions (mm) Size (measurements) (mm)
01	1/1	01	Base Base Base	1200x295x15
02	1/1	01	Lateral Esquerda Lateral Izquierda Right Left	800x295x15
03	1/1	01	Divisão División Division	800x295x15
04	1/1	01	Prateleira Menor Estante Pequeño Smaller Shelf	382x295x15
05	1/1	01	Lateral Direita Lateral Derecha Right Side	800x295x15
06	1/1	02	Prateleira Estante Shelf	772x295x15
07	1/1	01	Tampo Tapa Top	1200x322x15
08	1/1	01	Fundo Lateral Fondo Lateral Lateral Background	824x401x3
09	1/1	03	Fundo Fondo Bottom	791x274x3
10	1/1	03	Porta Puerta Door	813x396x15

Ferragens | Herrajes | Hardware

A Parafuso 5,0x50mm FLA. Tornillo 5,0x50mm FLA. Screw 5.0x50mm FLA.	03x	B Parafuso 3,5x40mm CHT. Tornillo 3,5x40mm CHT. Screw 3.5x40mm CHT.	16x	C Parafuso 3,5x14mm FLA. Tornillo 3,5x14mm FLA. Screw 3.5x14mm FLA.	42x	D Parafuso M4x20mm CHT. ZB Tornillo M4x20mm CHT. ZB Screw M4x20mm CHT. ZB	03x	E Cavilha 8x25mm Cinta 8x25mm Dowel 8x25mm	24x	F Calço Removível Calzado extraíble Removable Shim	06x
G Dobradica SlideOn Baixa Amortecedor 35mm Bisagra SlideOn Baja Amortiguador 35mm Low SlideOn Hinge 35mm Shock Absorber	06x	H Puxador Pontual PZ14 Oval Tirador Puntual PZ14 Oval PZ14 Oval Point Knob	03x	I Bucha plástica 8mm Bucha de plástico 8mm 8mm plastic bushing	03x	J Suporte de fixação Soporte de fijación Mounting bracket	03x	K Proteção para cantoneira Ángulo de protección Protection angle	03x	L Parafuso União 30mm Tornillo Unión 30mm Union Screw 30mm	04x
M Giz de correção Tiza de corrección Chalk of correction	02x	N Sachê de cola Bolsa de pegamento Glue bag	02x	O Adesivo tapa parafuso 10mm Adhesivo tapón de tornillo 10mm Bolt cover adhesive 10mm	19x	P Fixador de fundos Fijador de fondos Bottom fixer	21x	Q Prego 10x10mm Clavo 10x10mm Nail 10x10mm	66x	R Etiqueta resinada Henn Etiqueta resinada Henn Henn resin label	01x

O parafuso (A) deve ser usada somente quando este módulo for acoplado a outro módulo componível Henn.
El tornillo (L) se debe utilizar sólo cuando el módulo está conectado a otro módulo componible Henn.
The screw (L) should be used only when this module is attached to another Henn modular module.**RECOMENDAÇÃO**

Para fixar o móvel na parede usar o suporte de fixação (J), o parafuso 3,5x14mm FLA (C), a Bucha 8mm (I) e o parafuso 5,0x50mm FLA (A).

RECOMENDACIÓN

Para conectar el móvil a la pared con el soporte (J), tornillo 3,5 x14mm FLA (C), el casquillo de 8 mm (I) y el 5,0 x50mm tornillo FLA (A).

RECOMMENDATION

To fix the furniture to the wall use the fixing bracket (J), the 3.5x14mm FLA (C) screw, the 8mm bushing (I) and the 5.0x50mm FLA (A).

AVISO

Para limpeza do seu móvel, use uma franela seca ou úmida, e não utilize produtos químicos que possam danificar seu produto.

SISTEMA DE MONTAGEM

O sistema de montagem dos produtos funciona de acordo com a ordem crescente dos números indicados no desenho. Ex: 01, 02, 03, 04... até a conclusão da montagem.

ASSISTÊNCIA TÉCNICA

Para solicitação de Assistência Técnica você consumidor deverá entrar em contato com o Lojista a qual você realizou a compra deste produto e solicitar a assistência técnica das peças avariadas. A garantia abrange todas as peças, partes e componentes que eventualmente venham apresentar defeito de fabricação no prazo de 03 (três) meses, contando a partir da entrega do produto ao consumidor, mediante nota fiscal de compra. Se houver qualquer alteração na estrutura do produto ou ocorrer defeito por negligência do montador/consumidor em relação a instrução de montagem e manuseio, não será fornecido assistência técnica gratuita.

ADVERTENCIA

Para limpieza de su móvil, use una franela seca o húmeda, y no utilice productos químicos que puedan dañar su producto.

SISTEMA DE MONTAJE

El sistema de montaje de los productos funciona de acuerdo con el orden creciente de los números indicados en el dibujo. Ej.: 01, 02, 03, 04... hasta la conclusión del montaje.

ASISTENCIA TÉCNICA

Para solicitar Asistencia Técnica, el consumidor debe comunicarse con el Comercio que usted realizó la compra de este producto y solicita asistencia técnica para las partes dañadas. La garantía cubre todas las partes, piezas y componentes que eventualmente puedan presentar defecto de fabricación en el plazo de 03 (tres) meses, contados a partir de la entrega del producto al consumidor, mediante factura de compra. Si se produce algún cambio en la estructura del producto o se produce un defecto por negligencia del montador/consumidor en relación con las instrucciones de montaje y manipulación, no se prestará asistencia técnica gratuita.

NOTICE

To clean your furniture, use a dry or wet cloth, and do not use chemicals that may damage your product.

ASSEMBLY SYSTEM

The products' assembly system works according to the increasing order of the indicated numbers. For example: 01, 02, 03, 04... to the end of the assembly.

TECHNICAL ASSISTANCE

To request Technical Assistance, the consumer must contact the retailer from whom you purchased this product and request technical assistance for the damaged parts. The warranty covers all parts, parts and components that may eventually present a manufacturing defect within a period of 03 (three) months, counting from the delivery of the product to the consumer, by means of a purchase invoice. If there is any change in the structure of the product or defect occurs due to negligence of the assembler/consumer in relation to the assembly and handling instruction, free technical assistance will not be provided.

1º

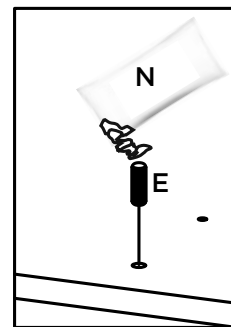
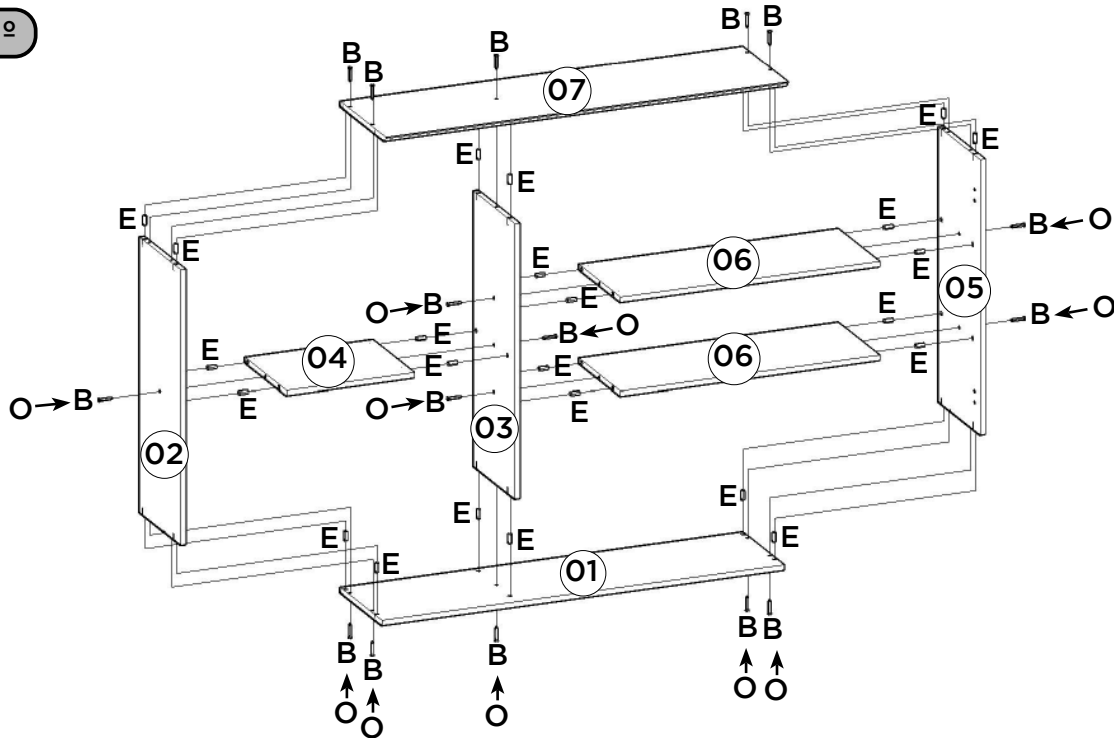

Utilizar o sachê de cola (N) em todas as cavilhas (E) do produto.

Con el pegamento sobre (N) en todos los pernos (E) producto.

Use the glue sachet (N) on all the pegs (E) of the product.

2º

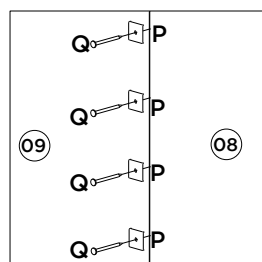
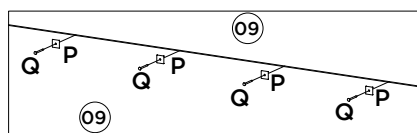
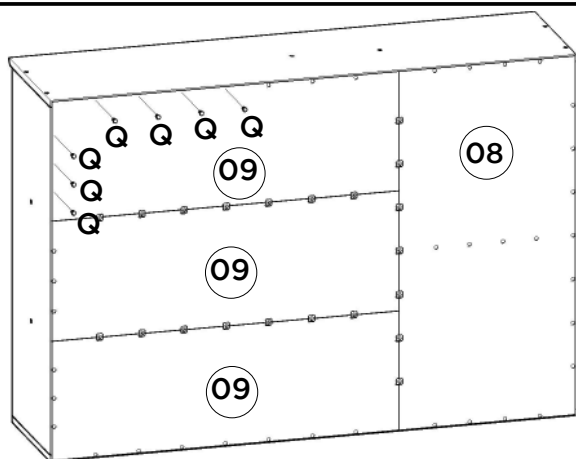

3º

Para saber mais sobre como fixar o móvel de maneira correta, acesse:

Para obtener más información sobre cómo arreglar los muebles correctamente, visite:

To learn more about how to fix the furniture correctly, visit:



<http://bit.ly/guia-de-fixacao-henn>

Imprescindível a fixação do produto na parede.
Es imprescindible la fijación del producto en la pared.
Indispensable to fix the product on the wall.

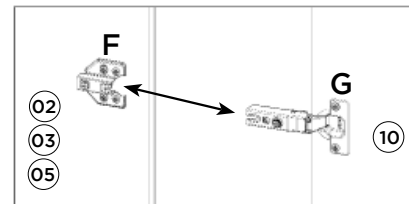
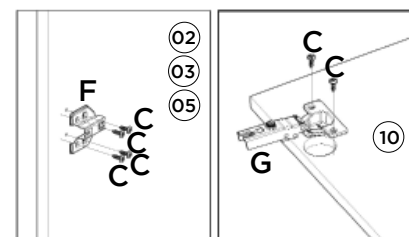
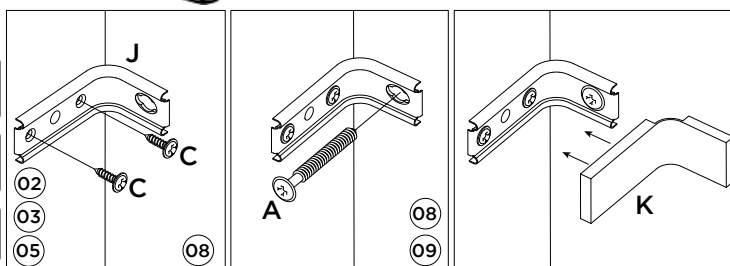

Video: Instalar e regular Dobradiças

Video: Instale y ajuste las bisagras

Video: Install and adjust hinges

Para colocação dos puxadores, é necessário fazer a furação passante, com Broca de 5mm.

Para la colocación de las asas, es necesario perforar a través, con una broca de 5mm.

To place the handles is necessary to make the through hole, drill 5mm.

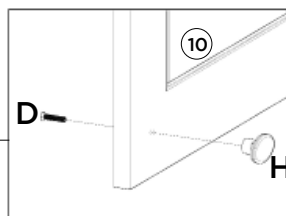
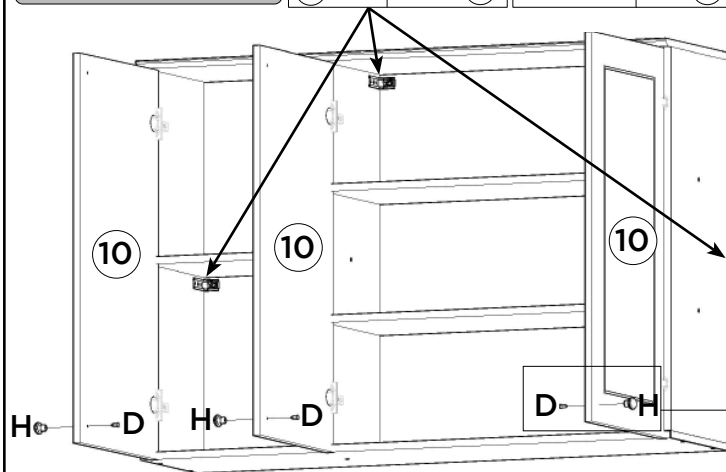

HENN

Ind. e Com. de Móveis Henn
Mondaí - SC - Brasil

+55 49 3674.3500

@moveishenn
www.henn.com.br

INSTRUÇÕES DE MONTAGEM

INSTRUCCIONES DE MONTAJE
ASSEMBLY INSTRUCTIONS

Balcão Pia 03 Gavetas 02 portas Americana |
Pia Contador 03 Cajones 02 Puertas Americana | Balcony Pia 03 Drawers 02 Doors Americana |

C353-05 Branco HP
C353-131 Cinza

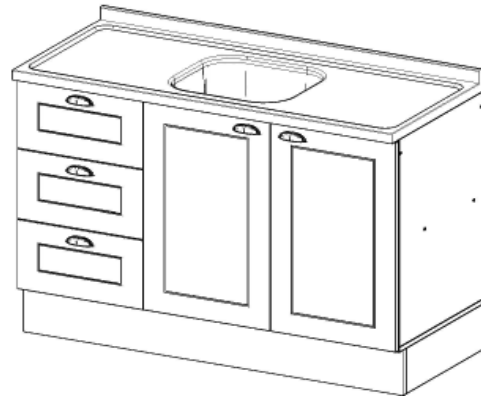
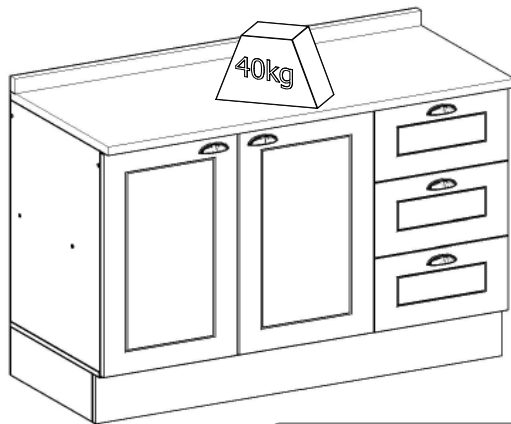
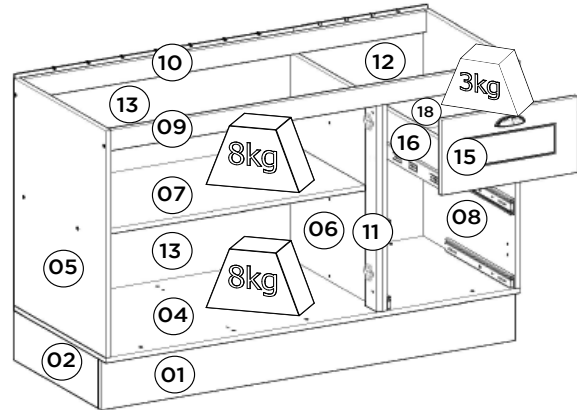
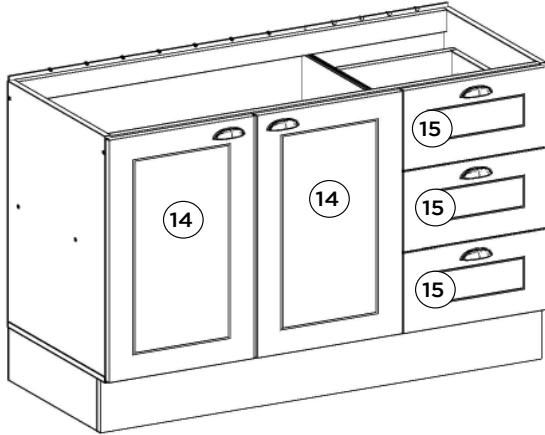

Pesos máximos recomendados
com carga distribuída
Peso máximo recomendado con la
carga distribuída
Recommended maximum weights
with evenly distributed.

Requisitos para montagem
Requisitor para la montaje
Assembly Requirements

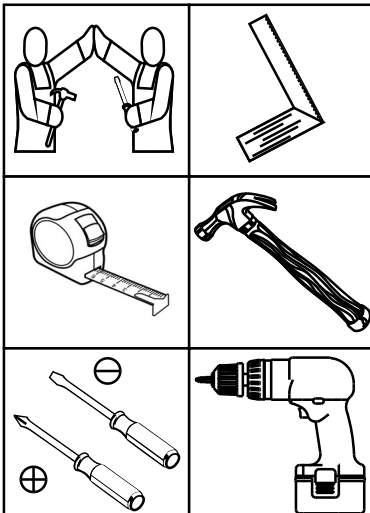

Imagens meramente ilustrativas
Imágenes meramente ilustrativas
Images for illustration only

AVISO

Para limpeza de seu móvel, use uma flanela seca ou umedecida, e não utilize produtos químicos que possam danificar seu produto.

SISTEMA DE MONTAGEM

O sistema de montagem dos produtos, funciona de acordo com a ordem crescente dos números indicados no desenho. Ex: 01, 02, 03, 04... até a conclusão da montagem.

ASSISTÊNCIA TÉCNICA

Para solicitação de Assistência Técnica você consumidor deverá entrar em contato com o Lojista o qual você realizou a compra deste produto e solicitar a assistência técnica das peças avariadas. A garantia abrange todas as peças, partes e componentes que eventualmente venham apresentar defeito de fabricação no prazo de 03 (três) meses, contando a partir da entrega do produto ao consumidor, mediante nota fiscal de compra. Se houver qualquer alteração na estrutura do produto ou ocorrer defeito por negligência do montador/consumidor em relação a instrução de montagem e manuseio, não será fornecido assistência técnica gratuita.

ADVERTENCIA

Para limpieza de su móvil, use una flanela seca o húmeda, y no utilice productos químicos que puedan dañar su producto.

SISTEMA DE MONTAJE

El sistema de montaje de los productos funciona de acuerdo con el orden creciente de los números indicados en el dibujo. Ej.: 01, 02, 03, 04... hasta la conclusión del montaje.

ASISTENCIA TÉCNICA

Para solicitar Asistencia Técnica, el consumidor debe comunicarse con el Comercio que usted realizó la compra de este producto y solicita asistencia técnica para las partes dañadas. La garantía cubre todas las partes, piezas y componentes que eventualmente puedan presentar defecto de fabricación en el plazo de 03 (tres) meses, contados a partir de la entrega del producto al consumidor, mediante factura de compra. Si se produce algún cambio en la estructura del producto o se produce un defecto por negligencia del montador/consumidor en relación con las instrucciones de montaje y manipulación, no se prestará asistencia técnica gratuita.

NOTICE

To clean your furniture, use a dry or wet cloth, and do not use chemicals that may damage your product.

ASSEMBLY SYSTEM

The products' assembly system works according to the increasing order of the indicated numbers. For example: 01, 02, 03, 04 ... to the end of the assembly.

TECHNICAL ASSISTANCE

To request Technical Assistance, the consumer must contact the retailer from whom you purchased this product and request technical assistance for the damaged parts. The warranty covers all parts, parts and components that may eventually present a manufacturing defect within a period of 03 (three) months, counting from the delivery of the product to the consumer, by means of a purchase invoice. If there is any change in the structure of the product or defect occurs due to negligence of the assembler/consumer in relation to the assembly and handling instruction, free technical assistance will not be provided.

1º

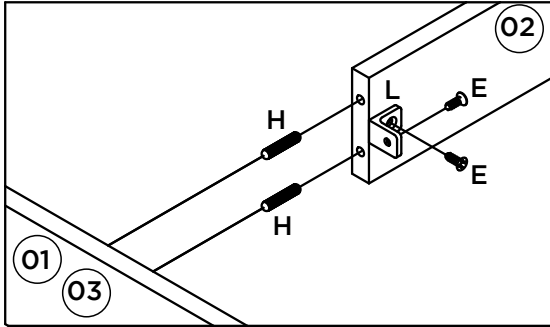
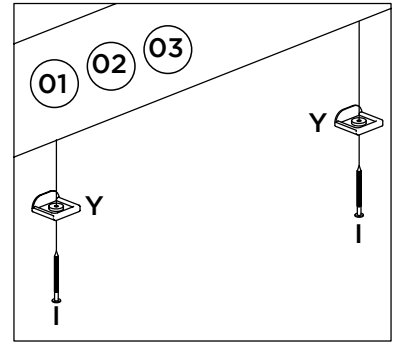
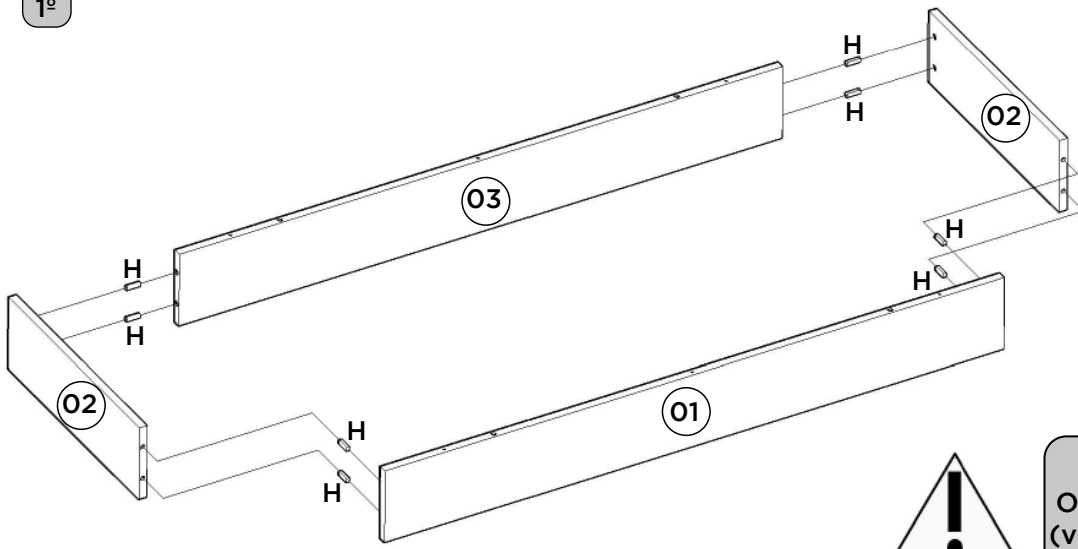

OPCIONAL:
 O945-121 Kit Pé Cônico 145mm (vendido separadamente). Caso opte em colocar pé no produto, utilizar as pré-furações que possui na Base e fixá-lo com o Parafuso que consta no Kit.

OPCIONAL:
 O945-121 Kit Pie Cónico 145mm (se vende por separado). Si opta por colocar pie en el producto, utilizar las pre-huracuras que tenga en la Base y fijarlo con el Tornillo que consta en el Kit.

OPTIONAL:
 O945-121 Tapered Foot Kit 145mm (sold separately). If you choose to put foot in the product, use the pre-drillings in the Base and fix it with the Screw included in the Kit.

2º

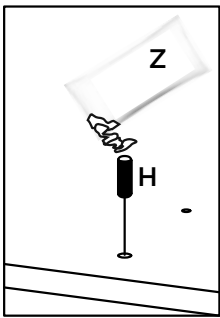

- Utilizar o sachê de cola (Z) em todas as cavilhas (H) do produto.
- Con el pegamento sobre (Z) en todos los pernos (H) producto.
- Use the glue sachet (Z) on all the pegs (H) of the product.

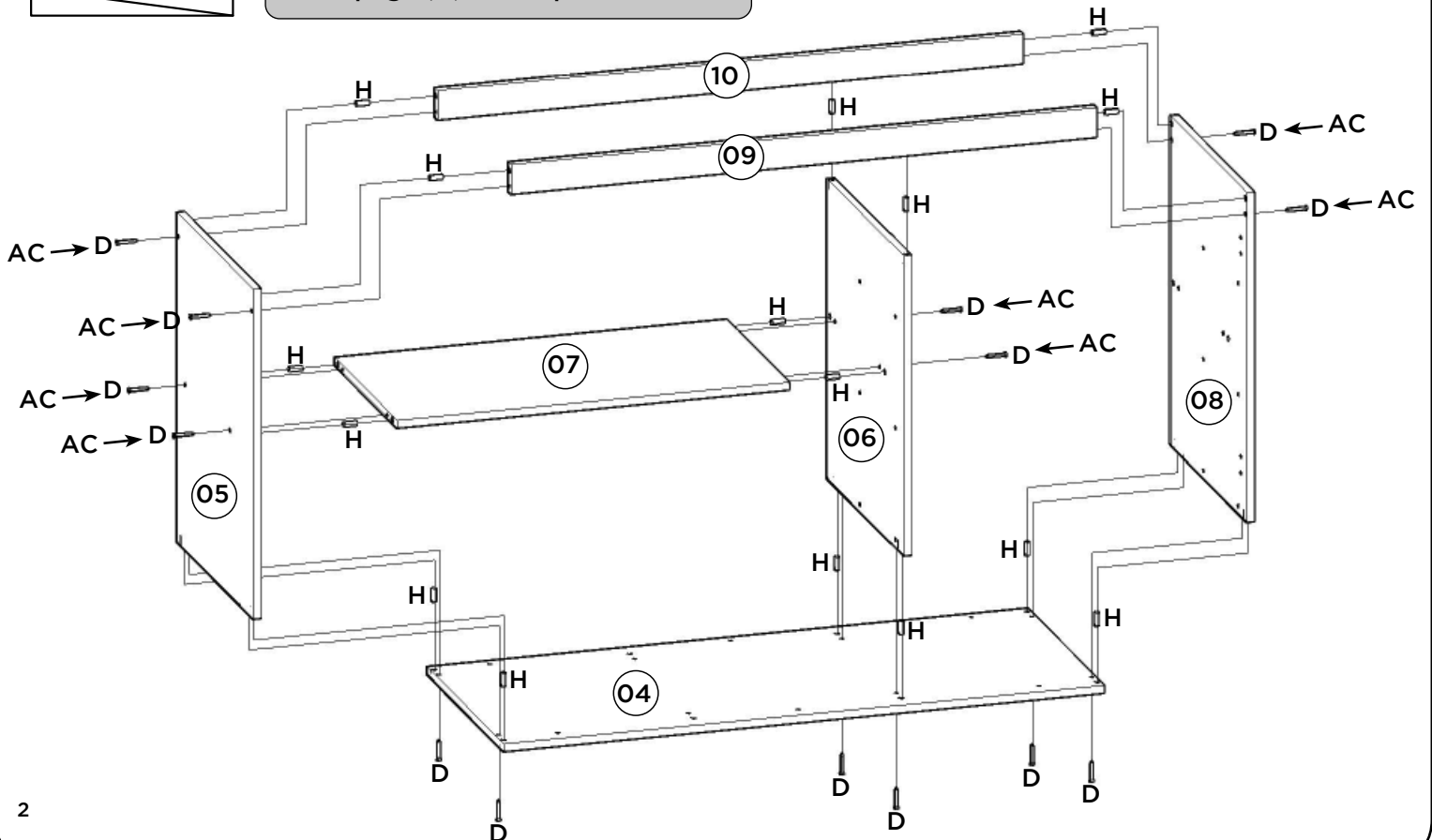

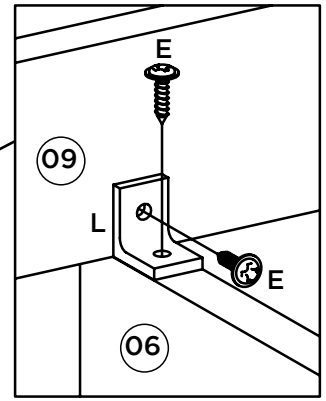
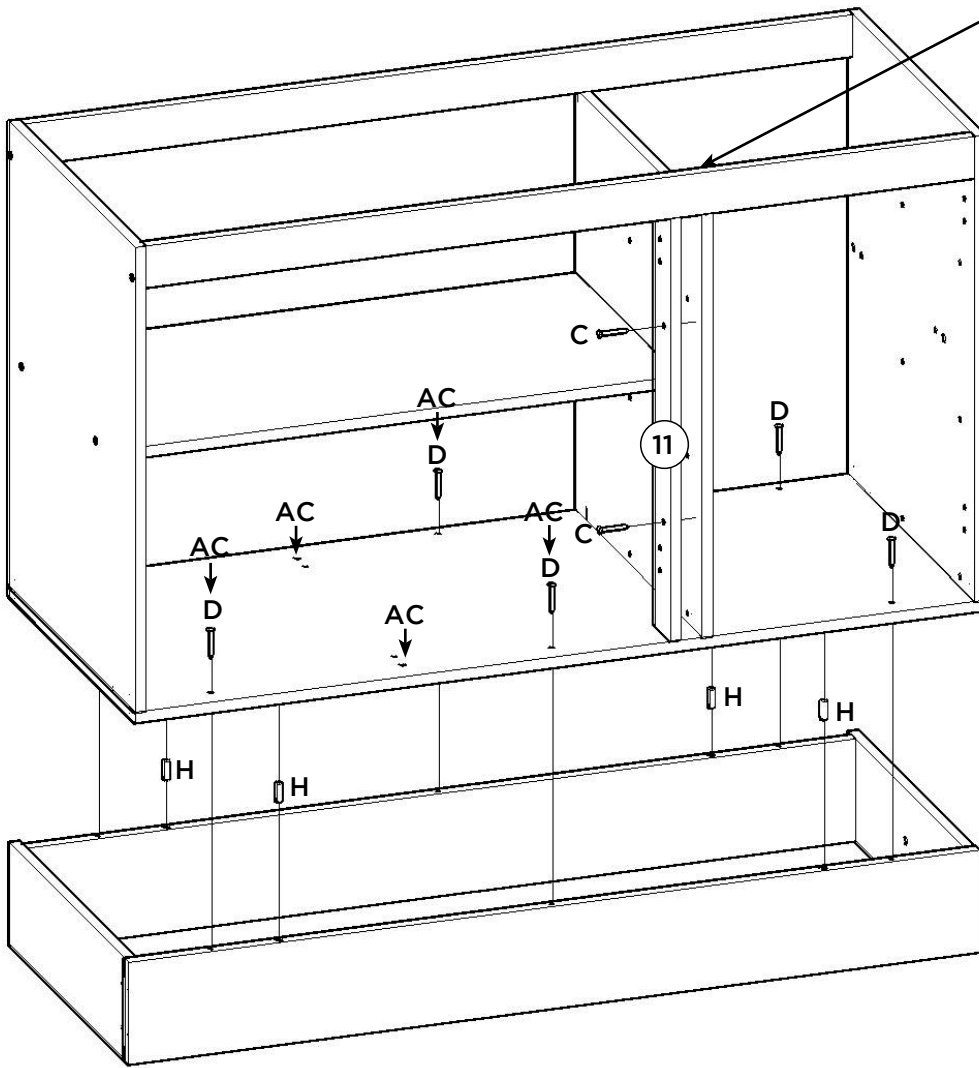

A pilastra da porta (11) deve estar alinhada com a divisão (06).

El pilar de la puerta (11) debe estar alineada con la división (06).

The door pillar (11) must be aligned with the partition (06).

Esse tampo é opcional e é vendido separadamente (C905-114).

Esta vez es opcional y se vende por separado (C905-114).

This top is optional and is sold separately (C905-114).

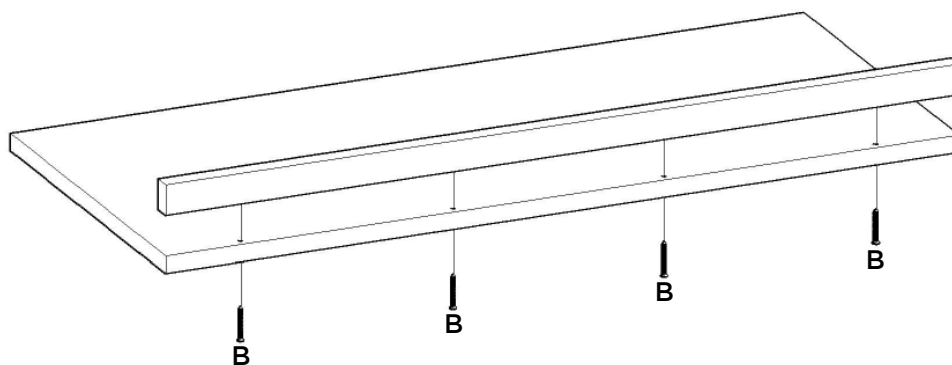

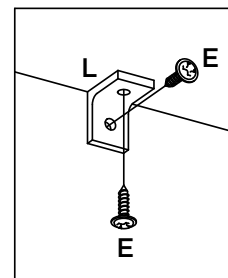
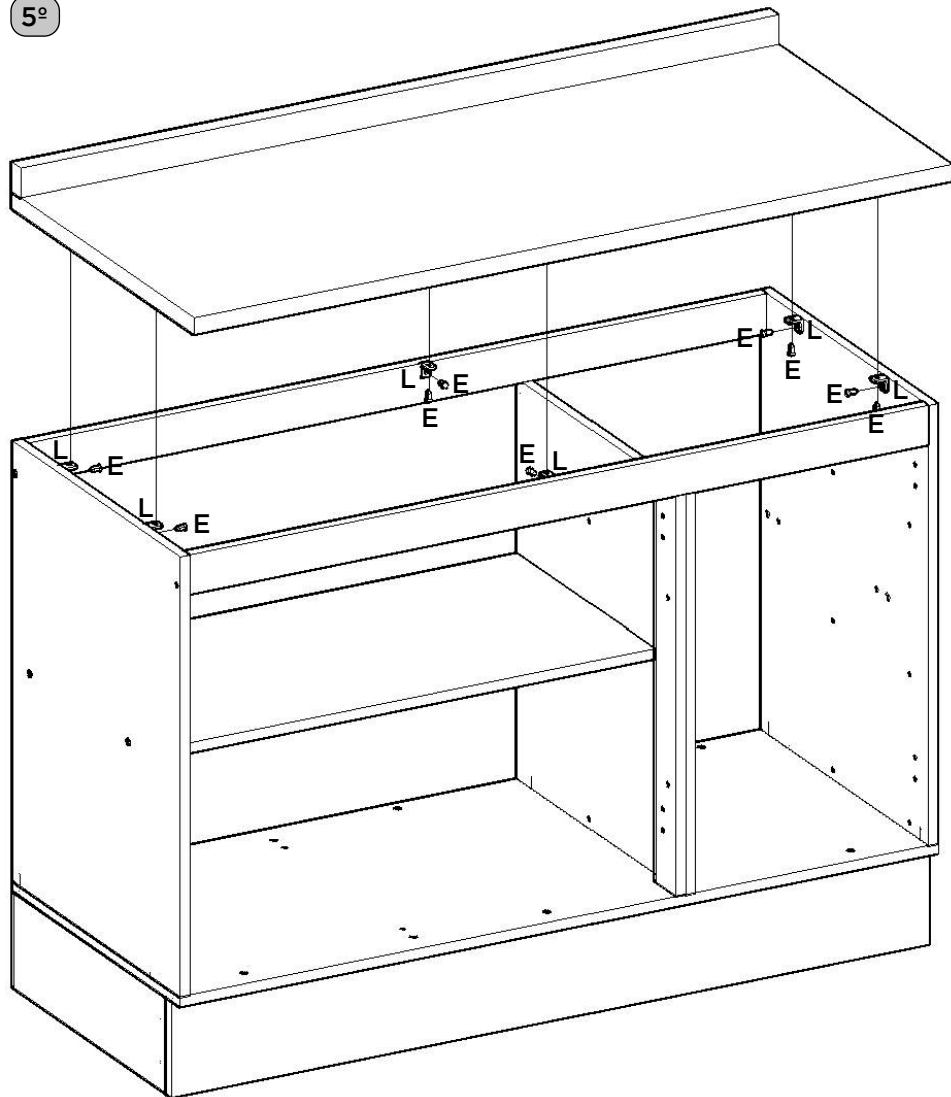

Caso o móvel seja montado com a opção do tampo, fixar o mesmo com 06 cantoneiras (L) e os parafusos 3,5x14mm (E).

Si se monta el auricular con la opción de la cubierta, fijarlo con Los ángulos 06 (L) y 3,5 x14mm tornillos (E).

If the furniture is to be installed with the top cover option, fix it with 06 (L) and 3.5x14mm screws (E).

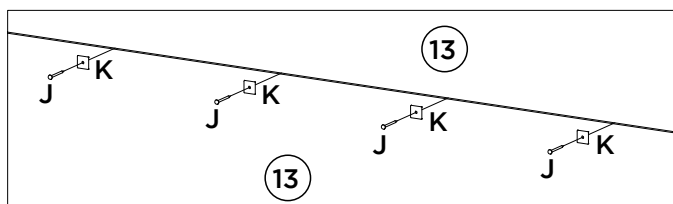
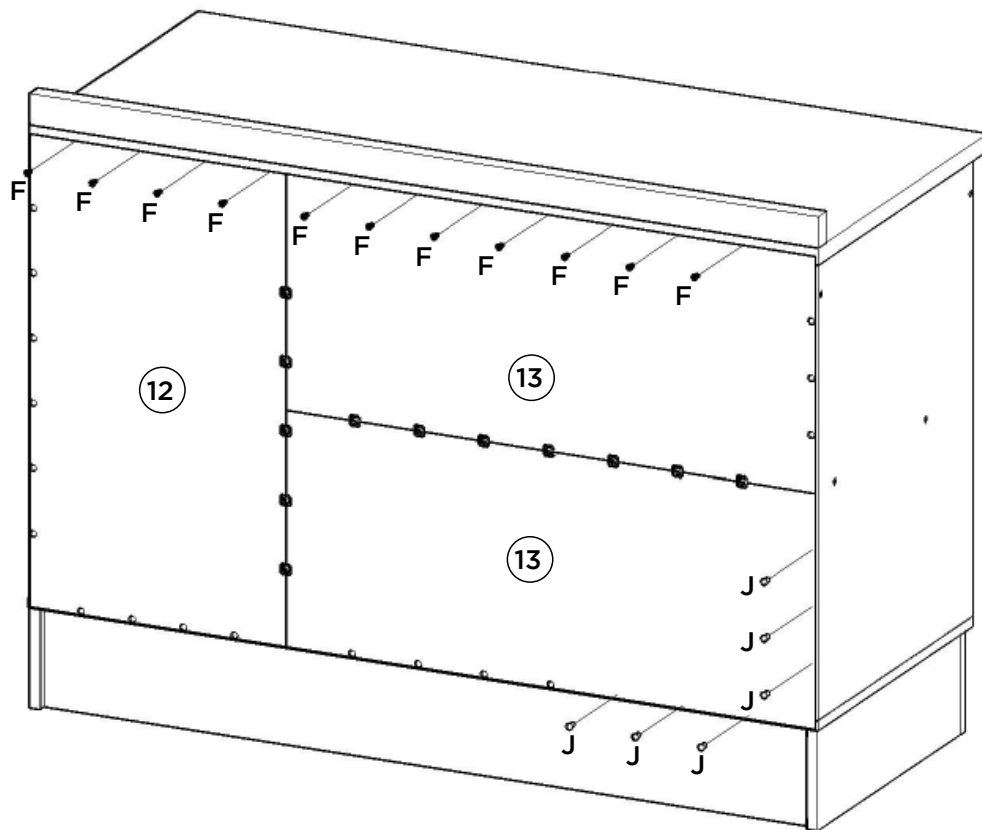
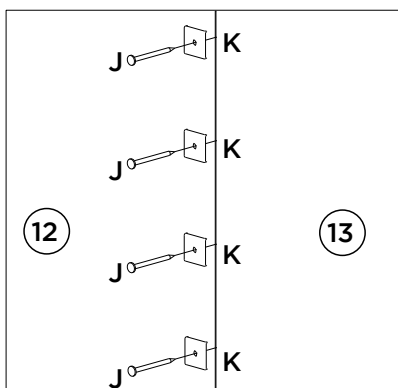

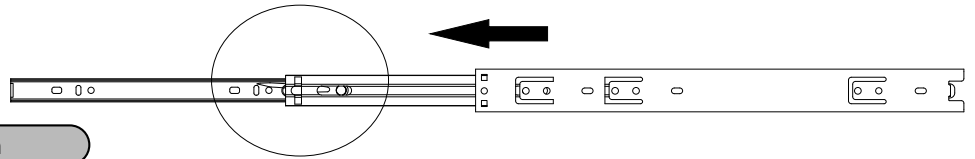
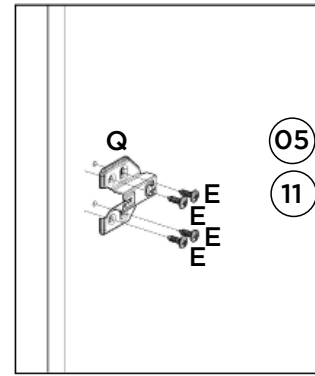
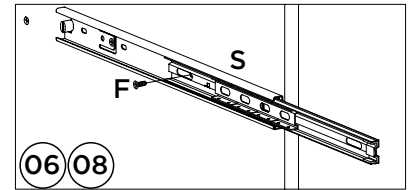
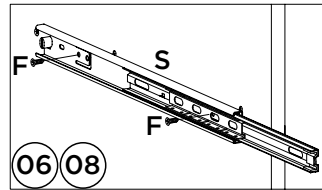
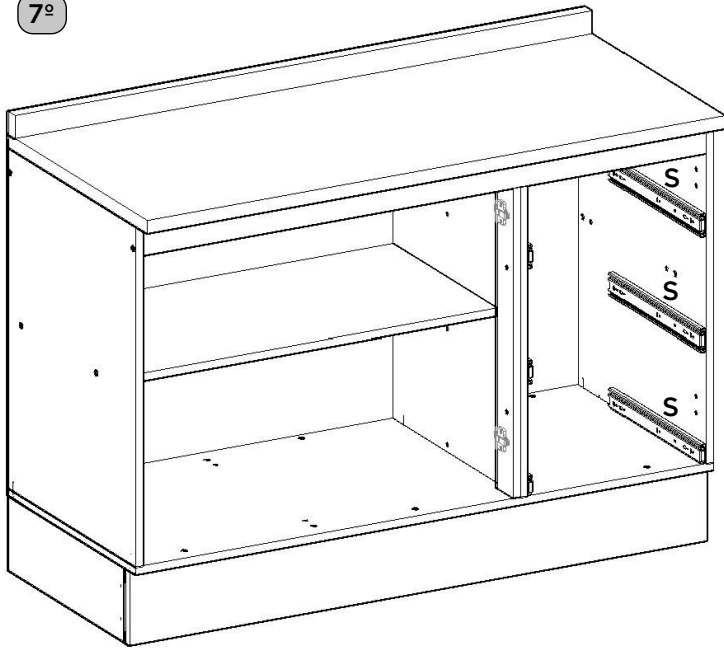

Vídeo: Dicas para fixar a Corrediça

Video: Consejos para arreglar la diapositiva

Video: Tips for Fixing the Slide

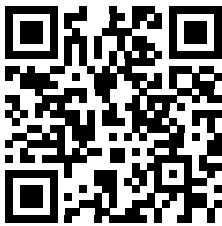

Para a desmontagem da corrediça siga a instrução ao lado.

Para el desmontaje seguimiento de diapositivas la instrucción siguiente a.

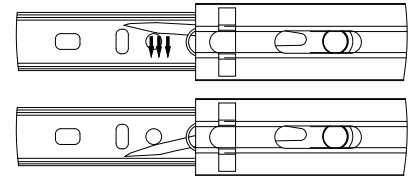

Fixar as corrediças nessas furações
Fijar las diapositivas de estos agujeros

Opção Suspensa

Opción suspendida

Suspended Option

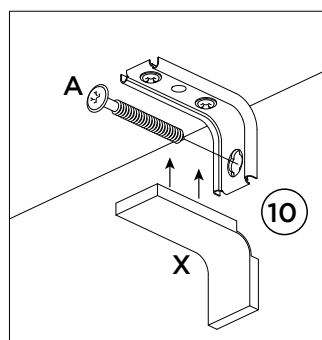
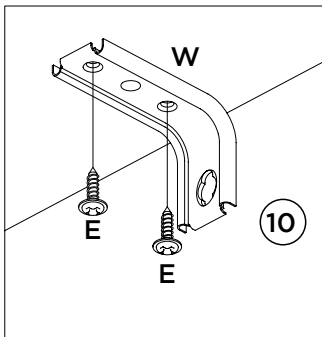

Parede
pared
Wall

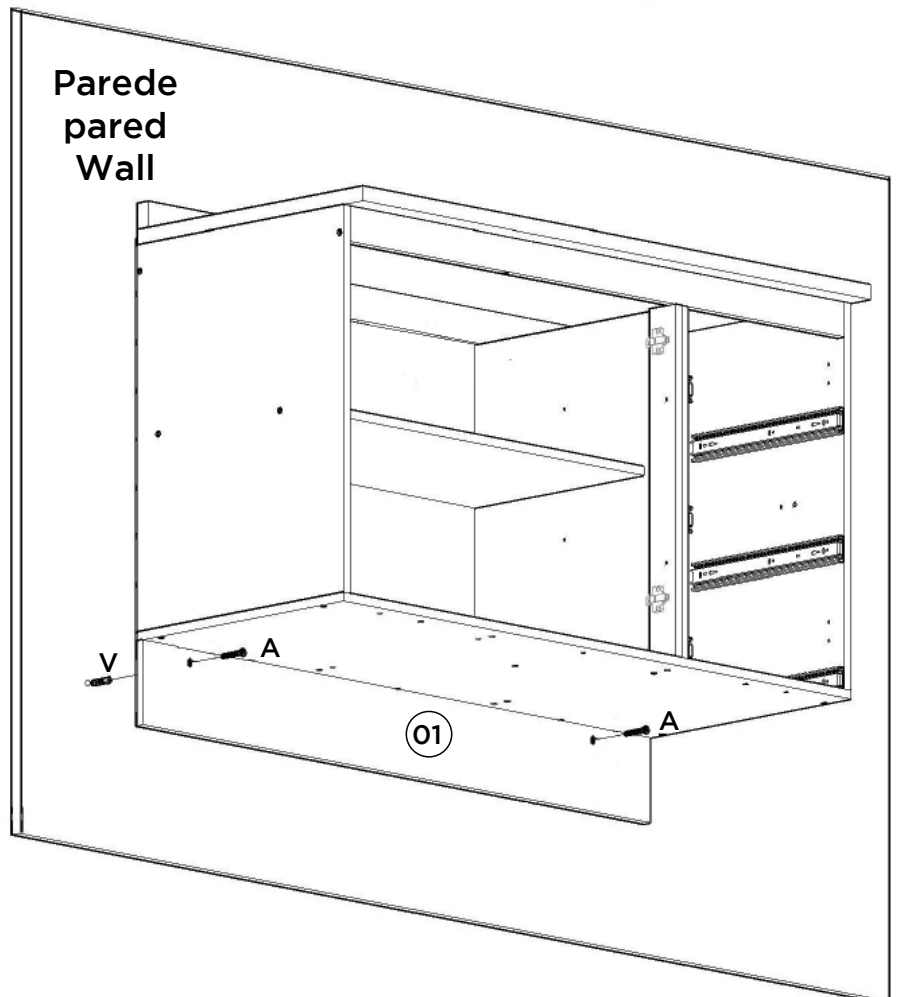

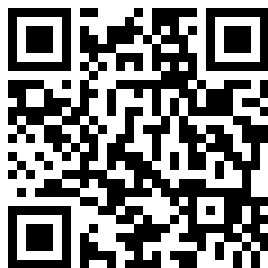
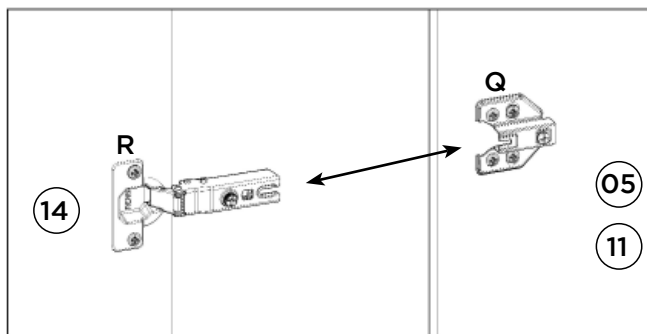
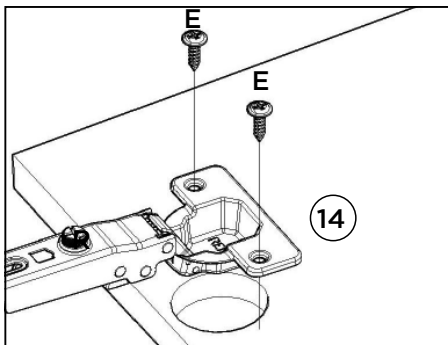

Vídeo: Instalar e regular Dobradiças

Video: Instale y ajuste las bisagras

Video: Install and adjust hinges

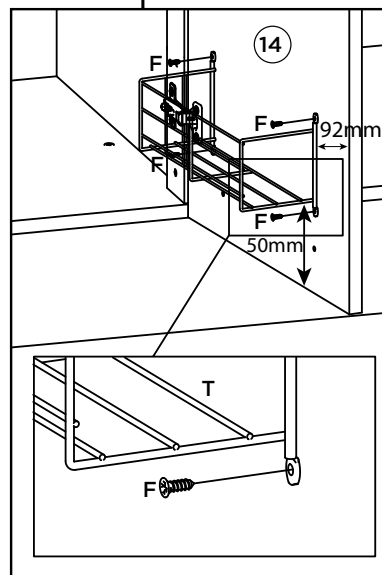
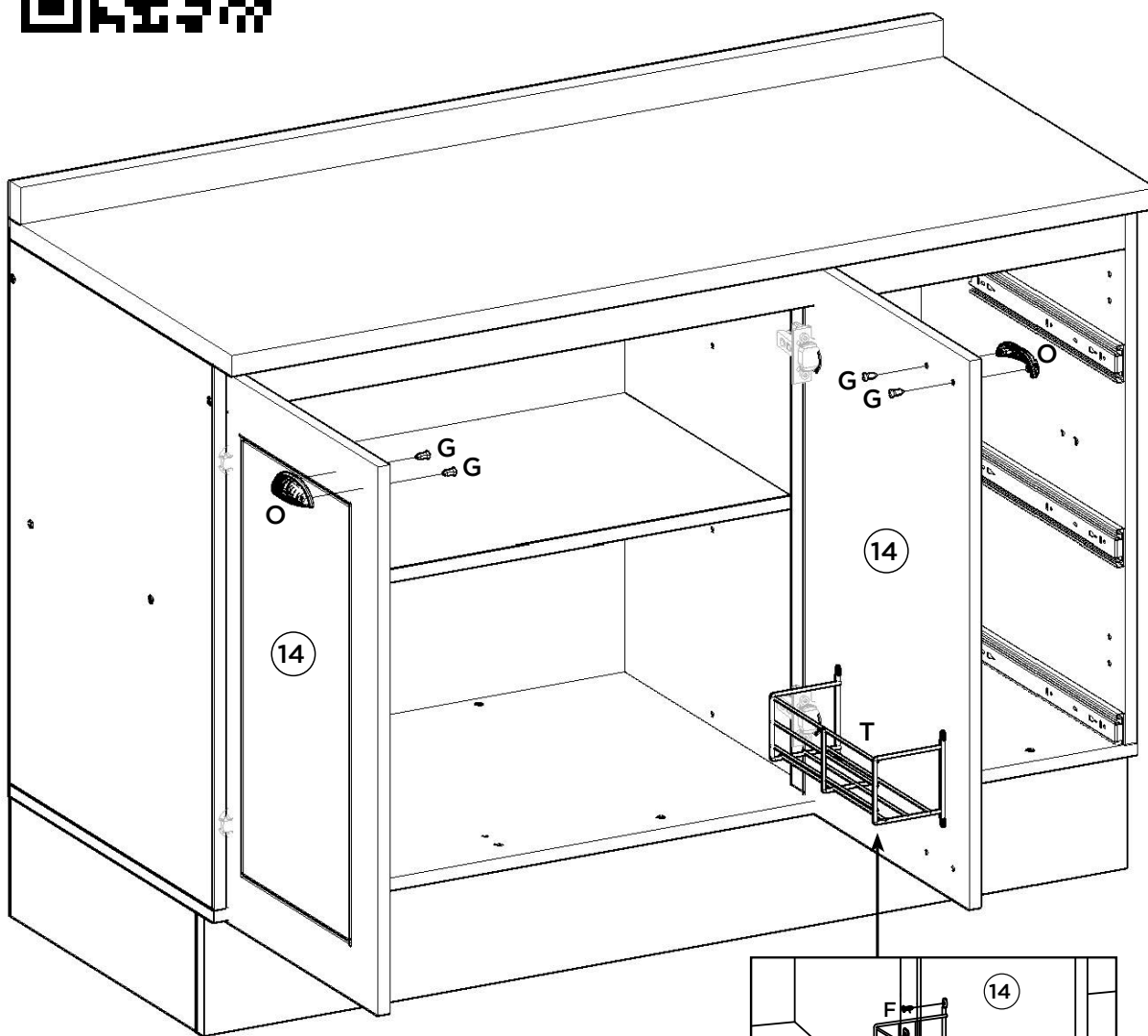

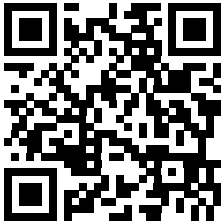
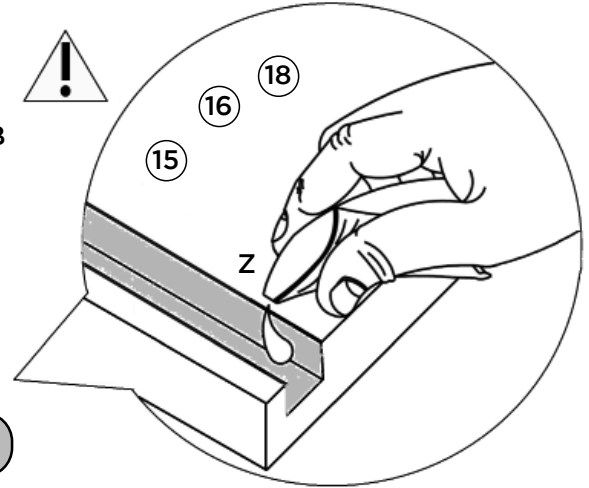
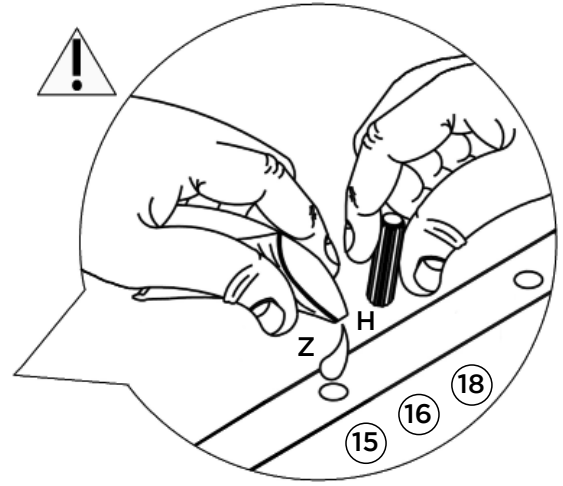
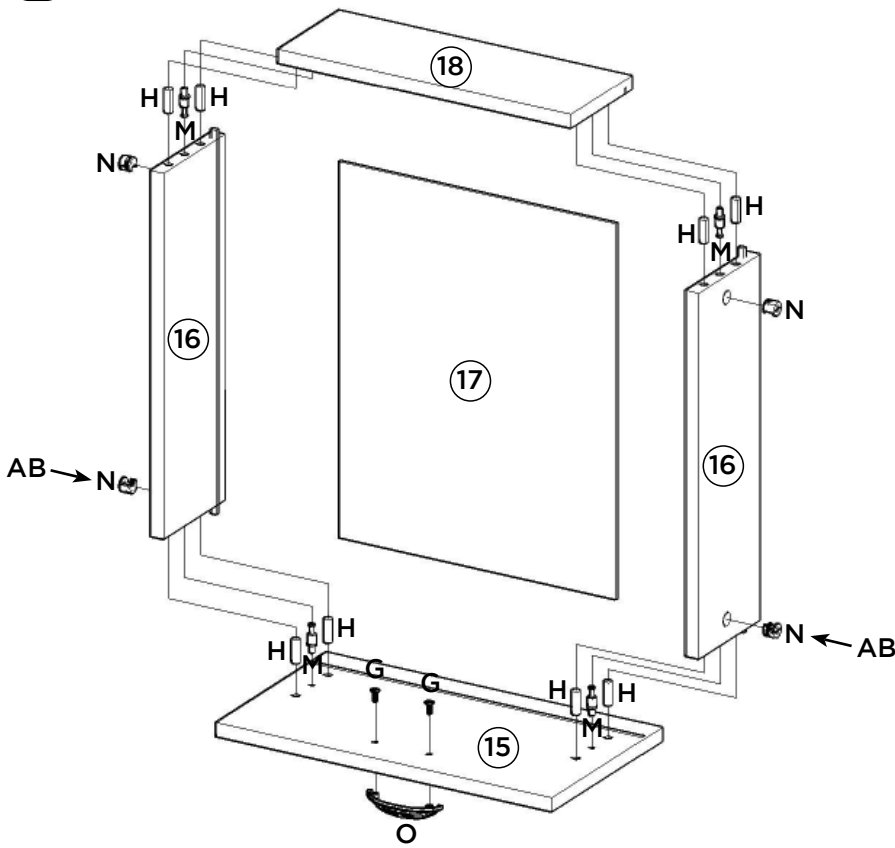

Vídeo: Dicas para fixar o Minifix

Video: Consejos para arreglar Minifix

Video: Tips for Fixing Minifix

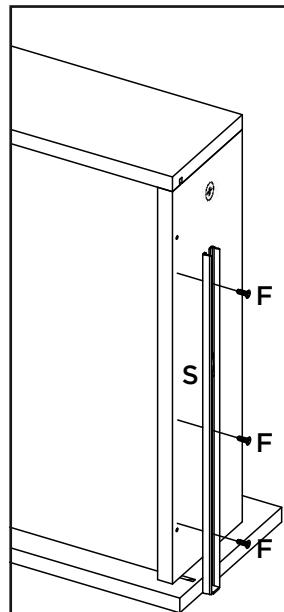
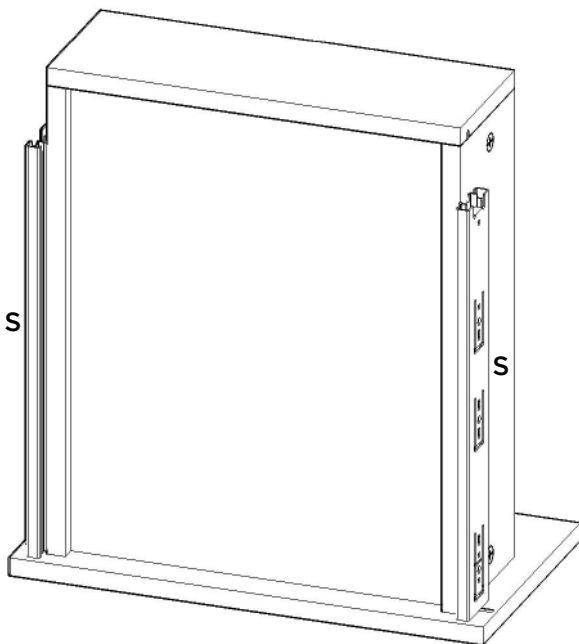

A corredeira (S) deverá ser alinhada com a parte de baixo do lado de gaveta (16).











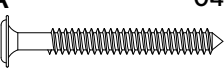







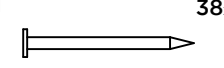



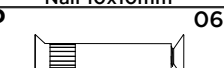

La carcasa (S) será alineada con la parte de por el lado del cajón (16).

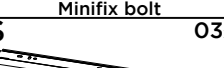
The slide (S) should be aligned with the underside of the drawer side (16).

Lista de Peças | Lista de piezas | List of parts

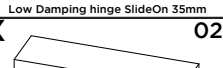
Item	Caixa Caja Box	Qty Ctd Qty	Descrição Descripción Description	Medidas (mm) Dimensions (mm) Size (measurements) (mm)
01	1/1	01	Rodapé Frontal Frente pie de página Front Footer	1200x145x15
02	1/1	02	Rodapé Lateral Pie de página Side Side Footer	450x145x15
03	1/1	01	Rodapé Traseiro Pie de página trasera Rear Footer	1168x145x15
04	1/1	01	Base Base Base	1200x490x15
05	1/1	01	Lateral esquerda Lateral izquierda Left side	660x490x15
06	1/1	01	Divisão División Division	600x490x15
07	1/1	01	Prateleira Estante Shelf	784x400x15
08	1/1	01	Lateral direita Lateral derecha Right side	660x490x15
09	1/1	01	Travessa frontal Travesaño frontal Front crossbar	1169x60x15
10	1/1	01	Travessa traseira Travesaño trasero Rear bumper	1169x60x15
11	1/1	01	Pilastra da Porta Pilastra Puerta Pilaster door	599x60x15
12	1/1	01	Fundo Lateral Fondo Lateral Lateral Background	683x389x3
13	1/1	02	Fundo Fondo Bottom	803x341x3
14	1/1	02	Porta Puerta Door	665x396x15
15	1/1	03	Frente de gaveta Frente de cajón Front of drawer	396x220x15
16	1/1	06	Lado de Gaveta Lado del cajón Drawer Side	400x122x15
17	1/1	03	Fundo de gaveta Fondo de cajón Bottom of drawer	411x326x3
18	1/1	03	Ripa de trás Malla detrás Rear lath	345x122x15

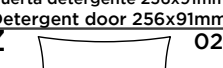
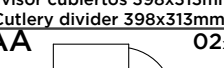
Ferragens | Herrajes | Hardware

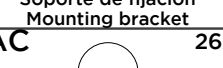
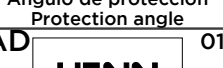
A  Parafuso 5,0x50mm FLA. Tornillo 5,0x50mm FLA. Screw 5,0x50mm FLA.	B  Parafuso 4,5x50mm CHT. Tornillo 4,5x50mm CHT. Screw 4,5x50mm CHT.	C  Parafuso 4,0x25mm CHT. Tornillo 4,0x25mm CHT. Screw 4,0x25mm CHT.	D  Parafuso 3,5x40mm CHT. Tornillo 3,5x40mm CHT. Screw 3,5x40mm CHT.	E  Parafuso 3,5x14mm FLA. Tornillo 3,5x14mm FLA. Screw 3,5x14mm FLA.	F  Parafuso 3,5x12mm CHT. Tornillo 3,5x12mm CHT. Screw 3,5x12mm CHT.
G  Parafuso M4x20mm CHT. ZB Tornillo M4x20mm CHT. ZB Screw M4x20mm CHT. ZB	H  Cavilha 8x25mm Cinta 8x25mm Dowel 8x25mm	I  Prego 12x12mm Anelado Clavo 12x12mm Anillado Ringed Nails 12x12mm	J  Prego 10x10mm Clavo 10x10mm Nail 10x10mm	K  Fixador de fundos Fijador de fondos Bottom fixer	L  Cantoneira plástica Cantонера plástica Plastic angle brackets
M  Parafuso minifix Tornillo minifix Minifix bolt	N  Tambor minifix Tambor minifix Minifix drum	O  Puxador Concha Tirador Concha Shell Handle	P  Parafuso União 30mm Tornillo Unión 30mm Union Screw 30mm	Q  Calço Removível Calzado extraíble Removable Shim	R  Dobradiça SlideOn Baixa Amortecimento 35mm Bisagra SlideOn Baja Amortiguación 35mm Low Damping hinge SlideOn 35mm
S  Corrediça telescópica Diapositivas telescópicas Telescopic slides	T  Porta detergente 256x91mm Puerta detergente 256x91mm Detergent door 256x91mm	U  Divisor talheres 398x313mm Divisor cubiertos 398x313mm Cutlery divider 398x313mm	V  Buchsa plástica 8mm Buchsa de plástico 8mm 8mm plastic bushing	W  Suporte de fixação Soporte de fijación Mounting bracket	X  Proteção para cantoneira Ángulo de protección Protection angle
Y  Sapata "L" 16x20mm Zapata "L" 16x20mm "L" shoe 16x20mm	Z  Sachê de cola Bolsa de pegamento Glue bag	AA  Giz de correção Tiza de corrección Chalk of correction	AB  Adesivo tapa parafuso 17mm Adhesivo tapón de tornillo 17mm Bolt cover adhesive 17mm	AC  Adesivo tapa parafuso 10mm Adhesivo tapón de tornillo 10mm Bolt cover adhesive 10mm	AD  HENN Etiqueta resinada Henn Etiqueta resinada Henn Henn resin label

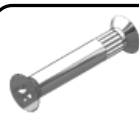

O parafuso (P) deve ser usada somente quando este módulo for acoplado a outro módulo componível Henn.

RECOMENDAÇÃO

Para fixar o móvel na parede usar o suporte de fixação (W), o parafuso 3,5x14mm FLA (E), a Buchsa 8mm (V) e o parafuso 5,0x50mm FLA (A).



El tornillo (P) se debe utilizar sólo cuando el módulo está conectado a otro módulo componible Henn.

RECOMENDACIÓN

Para conectar el móvil a la pared con el soporte (W), tornillo 3,5 x14mm FLA (E), el casquillo de 8 mm (V) y el 5,0 x50mm tornillo FLA (A).



The screw (P) should be used only when this module is attached to another Henn modular module.

RECOMMENDATION

To fix the furniture to the wall use the mounting bracket (W), the 3.5x14mm FLA (E) screw, the 8mm bushing (V) and the 5.0x50mm FLA screw (A).

HENN

Ind. e Com. de Móveis Henn
Mondai - SC - Brasil

+55 49 3674.3500

@f@moveishenn
www.henn.com.br

INSTRUÇÕES DE MONTAGEM

INSTRUCCIONES DE MONTAJE
ASSEMBLY INSTRUCTIONS

Aéreo 01 Porta Basculante 800mm Americana | Aéreo 01 Puerta Basculante 800mm Americana | 01 air port Tipper 800mm Americana

c C354-05 Branco HP

c C354-131 Cinza

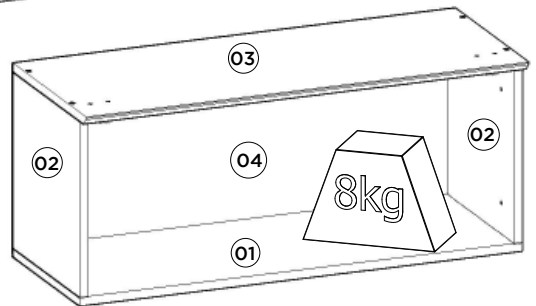
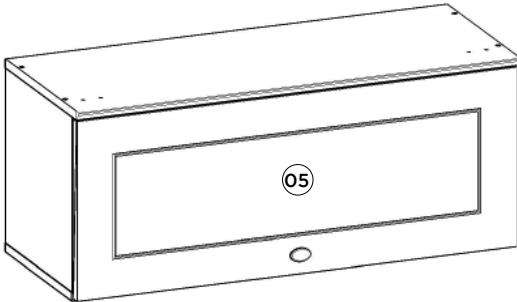

Pesos máximos recomendados
com carga distribuída
Peso máximo recomendado con
la carga distribuída
Recommended maximum weight
with distributed load.

Requisitos para montagem
Requisitos para la montaje
Assembly Requirements

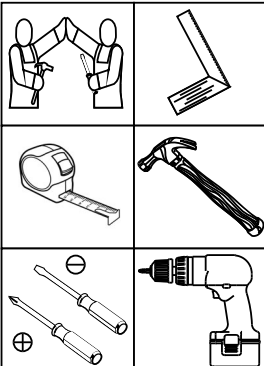

Imagens meramente ilustrativas
Imágenes meramente ilustrativas
Images for illustration only

AVISO

Para limpeza de seu móvel, use uma flanela seca ou umedecida, e não utilize produtos químicos que possam danificar seu produto.

SISTEMA DE MONTAGEM

O sistema de montagem dos produtos, funciona de acordo com a ordem crescente dos números indicados no desenho. Ex: 01, 02, 03, 04... até a conclusão da montagem.

ASSISTÊNCIA TÉCNICA

Para solicitação de Assistência Técnica você consumidor deverá entrar em contato com o Lojista o qual você realizou a compra deste produto e solicitar a assistência técnica das peças avariadas. A garantia abrange todas as peças, partes e componentes que eventualmente venham apresentar defeito de fabricação no prazo de 03 (três) meses, contando a partir da entrega do produto ao consumidor, mediante nota fiscal de compra. Se houver qualquer alteração na estrutura do produto ou ocorrer defeito por negligência do montador/consumidor em relação a instrução de montagem e manuseio, não será fornecido assistência técnica gratuita.

ADVERTENCIA

Para limpeza de su móvil, use una flanela seca o húmeda, y no utilice productos químicos que puedan dañar su producto.

SISTEMA DE MONTAJE

El sistema de montaje de los productos funciona de acuerdo con el orden creciente de los números indicados en el dibujo. Ej.: 01, 02, 03, 04... hasta la conclusión del montaje.

ASISTENCIA TÉCNICA

Para solicitar Asistencia Técnica, el consumidor debe comunicarse con el Comercio que usted realizó la compra de este producto y solicita asistencia técnica para las partes dañadas. La garantía cubre todas las partes, piezas y componentes que eventualmente puedan presentar defecto de fabricación en el plazo de 03 (tres) meses, contados a partir de la entrega del producto al consumidor, mediante factura de compra. Si se produce algún cambio en la estructura del producto o se produce un defecto por negligencia del montador/consumidor en relación con las instrucciones de montaje y manipulación, no se prestará asistencia técnica gratuita.

NOTICE

To clean your furniture, use a dry or wet cloth, and do not use chemicals that may damage your product.

ASSEMBLY SYSTEM

The products' assembly system works according to the increasing order of the indicated numbers. For example: 01, 02, 03, 04 ... to the end of the assembly.

TECHNICAL ASSISTANCE

To request Technical Assistance, the consumer must contact the retailer from whom you purchased this product and request technical assistance for the damaged parts. The warranty covers all parts, parts and components that may eventually present a manufacturing defect within a period of 03 (three) months, counting from the delivery of the product to the consumer, by means of a purchase invoice. If there is any change in the structure of the product or defect occurs due to negligence of the assembler/consumer in relation to the assembly and handling instruction, free technical assistance will not be provided.

1º

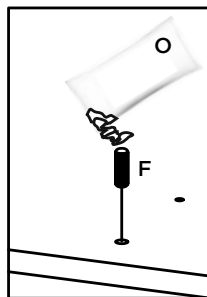
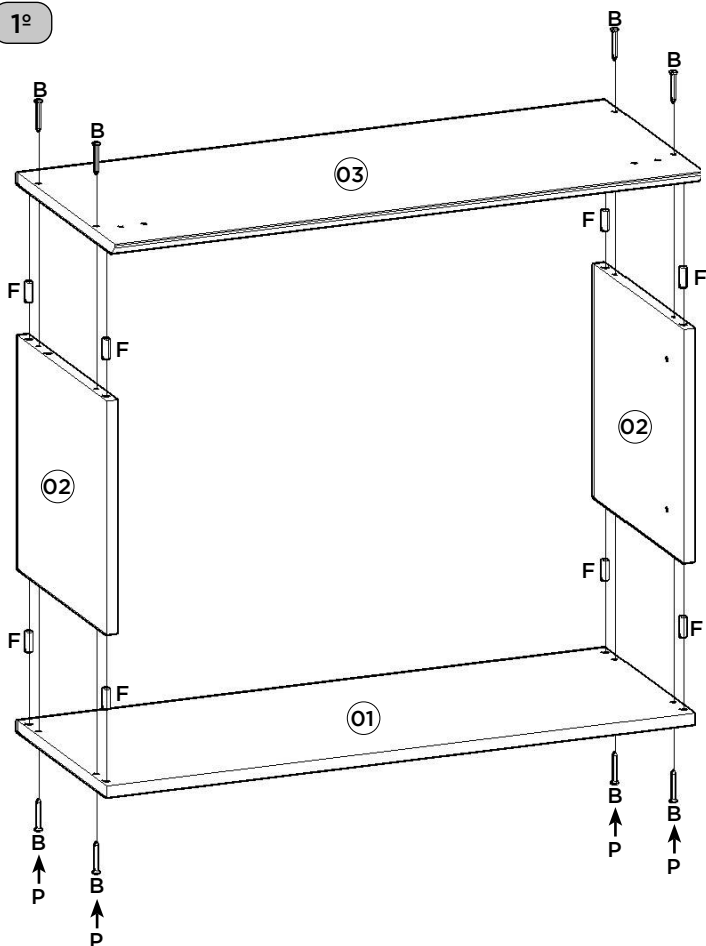

Utilizar o sachê de cola (O)
em todas as cavilhas (F)
do produto.

Con el pegamento sobre (O)
en todos los pernos (F)
producto.

Use the glue sachet (O) on all
the pegs (F) of the product.

2º

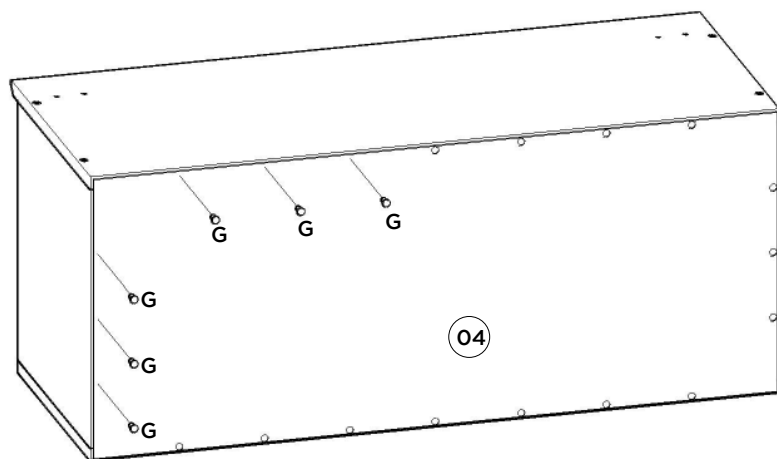

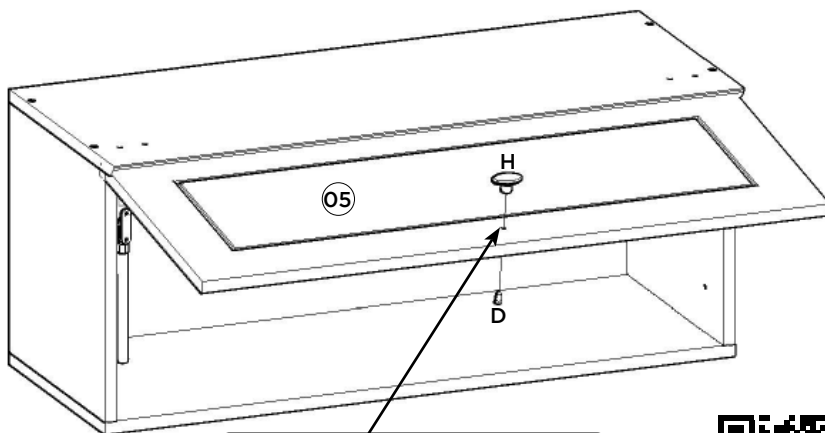

Para colocação do puxador, é necessário fazer a furação passante, com broca de 5mm.

Para colocar el mango, es necesario perforar con un taladro de 5 mm.

For placing the handle, it is necessary to drill through with a 5mm drill.



Video: Instalar e regular Dobradiças

Video: Instale y ajuste las bisagras

Video: Install and adjust hinges

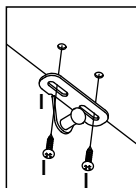
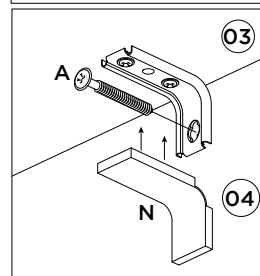
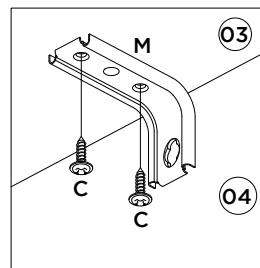
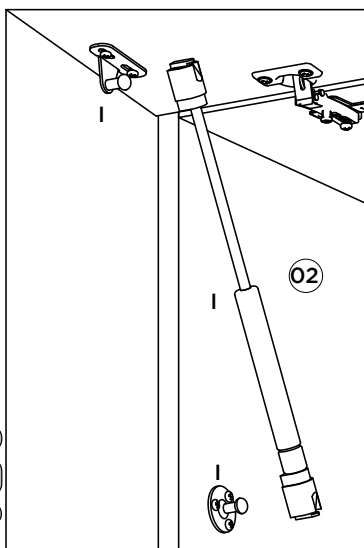
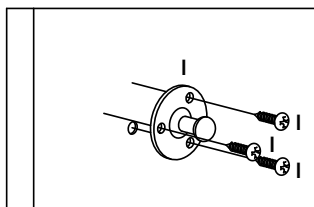
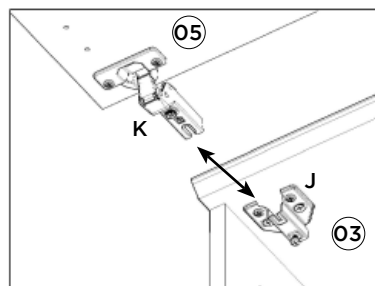
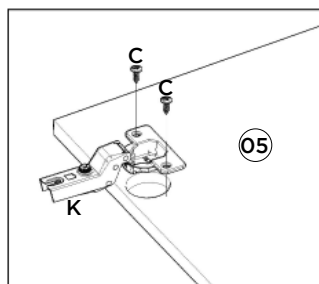
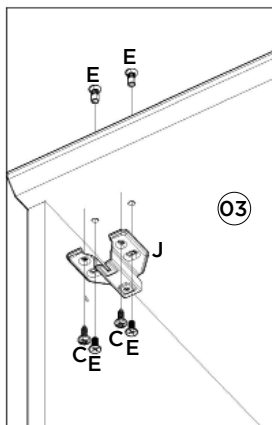

Video: Dicas para instalar o Kit Pistão à Gás













Video: Consejos para instalar el kit de pistón de gas

Video: Tips for installing the Gas Piston Kit

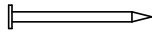
Lista de Peças | Lista de piezas | List of parts

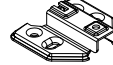
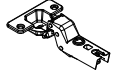
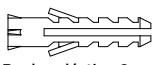
Item	Caixa Caja Box	Qty Ctd Qty	Descrição Descripción Description	Medidas (mm) Dimensions (mm) Size (measurements) (mm)
01	1/1	01	Base Base Base	800x295x15
02	1/1	02	Lateral Direita Esquerda Lateral Derecha Izquierda Right Side Left	307x295x15
03	1/1	01	Tampo Tapa Top	800x322x15
04	1/1	01	Fundo Fondo Bottom	793x331x3
05	1/1	01	Porta Basculante Puerta Basculante Basculating Door	796x315x15

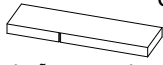
Ferragens | Herrajes | Hardware

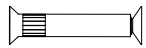
A  Parafuso 5,0x50mm FLA. Tornillo 5,0x50mm FLA. Screw 5,0x50mm FLA.	02x	B  Parafuso 3,5x40mm CHT. Tornillo 3,5x40mm CHT. Screw 3,5x40mm CHT.	08x	C  Parafuso 3,5x14mm FLA. Tornillo 3,5x14mm FLA. Screw 3,5x14mm FLA.	12x	D  Parafuso M4x20mm CHT. ZB Tornillo M4x20mm CHT. ZB Screw M4x20mm CHT. ZB	01x	E  Parafuso União 15mm Tornillo Unión 15mm Union Screw 15mm	04x
F  Cavilha 8x25mm Cinta 8x25mm Dowel 8x25mm	08x	G  Prego 10x10mm Clavo 10x10mm Nail 10x10mm	20x	H  Puxador Pontual PZ14 Oval Tirador Pontual PZ14 Oval PZ14 Oval Point Knob	01x	I  Kit Pistão a Gás 60N Kit Pistón a Gas 60N 60N Gas Piston Kit	01x	J  Calço Removível Calzado extraíble Removable Shim	02x
K  Dobradiça SlideOn Super Alta Amort. 35mm Bisagra Super high amort de Slideon. 35mm Slideon Super High Amort hinge. 35mm	02x	L  Bucha plástica 8mm Bucha de plástico 8mm 8mm plastic bushing	02x	M  Suporte de fixação Soporte de fijación Mounting bracket	02x	N  Proteção para cantoneira Ángulo de protección Protection angle	02x	O  Sachê de cola Bolsa de pegamento Glue bag	01x
P  Adesivo tampa parafuso 10mm Adhesivo tapón de tornillo 10mm Bolt cover adhesive 10mm	08x	Q  Parafuso União 30mm Tornillo Unión 30mm Union Screw 30mm	04x						



O parafuso (Q) deve ser usada somente quando este módulo for acoplado a outro módulo componível Henn.



El tornillo (Q) se debe utilizar sólo cuando el módulo está conectado a otro módulo componible Henn.



The screw (Q) should be used only when this module is attached to another Henn modular module.

RECOMENDAÇÃO

Para fixar o móvel na parede usar o suporte de fixação (M), o parafuso 3,5x14mm FLA (C), a Bucha 8mm (L) e o parafuso 5,0x50mm FLA (A).

RECOMENDACIÓN

Para conectar el móvil a la pared con el soporte (M), tornillo 3,5 x14mm FLA (C), el casquillo de 8 mm (L) y el 5,0 x50mm tornillo FLA (A).

RECOMMENDATION

To fix the furniture to the wall use the fixing bracket (M), the 3.5x14mm FLA (C) screw, the 8mm bushing (L) and the 5.0x50mm FLA screw (A).

HENN

Ind. e Com. de Móveis Henn
Mondai - SC - Brasil

+55 49 3674.3500

@moveishenn
www.henn.com.br

INSTRUÇÕES DE MONTAGEM

INSTRUCCIONES DE MONTAJE
ASSEMBLY INSTRUCTIONS

Torre Quente 2 Fornos Americana | Torre caliente 2 Hornos Americana | 2 Hot Americana Tower furnaces

C351-05 Branco HP/Calcare BP
C351-156 Branco HP/Nature
C351-131 Cinza/Calcare BP
C351-169 Cinza/Nature

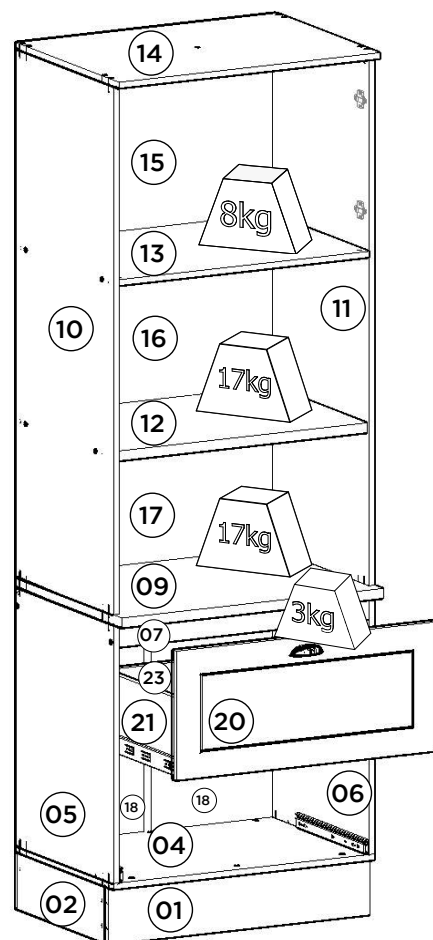
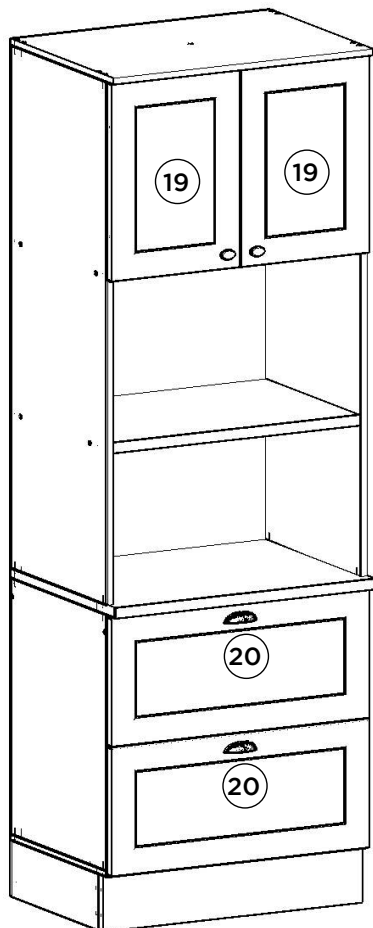

Pesos máximos recomendados com carga distribuída
Peso máximo recomendado con la carga distribuida
Recommended maximum weights with evenly distributed.

AVISO

Para limpeza de seu móvel, use uma flanela seca ou umedecida, e não utilize produtos químicos que possam danificar seu produto.

SISTEMA DE MONTAGEM

O sistema de montagem dos produtos, funciona de acordo com a ordem crescente dos números indicados no desenho. Ex: 01, 02, 03, 04... até a conclusão da montagem.

ASSISTÊNCIA TÉCNICA

Para solicitação de Assistência Técnica você consumidor deverá entrar em contato com o Lojista o qual você realizou a compra deste produto e solicitar a assistência técnica das peças avariadas. A garantia abrange todas as peças, partes e componentes que eventualmente venham apresentar defeito de fabricação no prazo de 03 (três) meses, contando a partir da entrega do produto ao consumidor, mediante nota fiscal de compra. Se houver qualquer alteração na estrutura do produto ou ocorrer defeito por negligência do montador/consumidor em relação a instrução de montagem e manuseio, não será fornecido assistência técnica gratuita.

ADVERTENCIA

Para limpieza de su móvil, use una flanela seca o húmeda, y no utilice productos químicos que puedan dañar su producto.

SISTEMA DE MONTAJE

El sistema de montaje de los productos funciona de acuerdo con el orden creciente de los números indicados en el dibujo. Ej.: 01, 02, 03, 04... hasta la conclusión del montaje.

ASISTENCIA TÉCNICA

Para solicitar Asistencia Técnica, el consumidor debe comunicarse con el Comercio que usted realizó la compra de este producto y solicita asistencia técnica para las partes dañadas. La garantía cubre todas las partes, piezas y componentes que eventualmente puedan presentar defecto de fabricación en el plazo de 03 (tres) meses, contados a partir de la entrega del producto al consumidor, mediante factura de compra. Si se produce algún cambio en la estructura del producto o se produce un defecto por negligencia del montador/consumidor en relación con las instrucciones de montaje y manipulación, no se prestará asistencia técnica gratuita.

NOTICE

To clean your furniture, use a dry or wet cloth, and do not use chemicals that may damage your product.

ASSEMBLY SYSTEM

The products' assembly system works according to the increasing order of the indicated numbers. For example: 01, 02, 03, 04 ... to the end of the assembly.

TECHNICAL ASSISTANCE

To request Technical Assistance, the consumer must contact the retailer from whom you purchased this product and request technical assistance for the damaged parts. The warranty covers all parts, parts and components that may eventually present a manufacturing defect within a period of 03 (three) months, counting from the delivery of the product to the consumer, by means of a purchase invoice. If there is any change in the structure of the product or defect occurs due to negligence of the assembler/consumer in relation to the assembly and handling instruction, free technical assistance will not be provided.

Requisitos para montagem Requisitos para la montaje Assembly Requirements

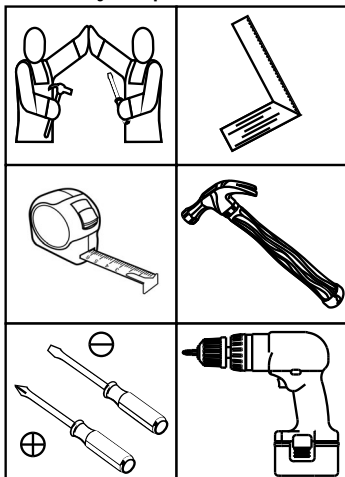

Imagens meramente ilustrativas,
não acompanha o produto.
Imágenes ilustrativas, no incluidas
con el producto.
Illustrative images, not included
with the product.

1º

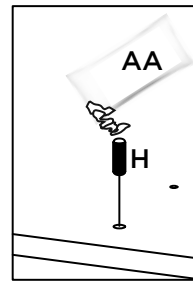
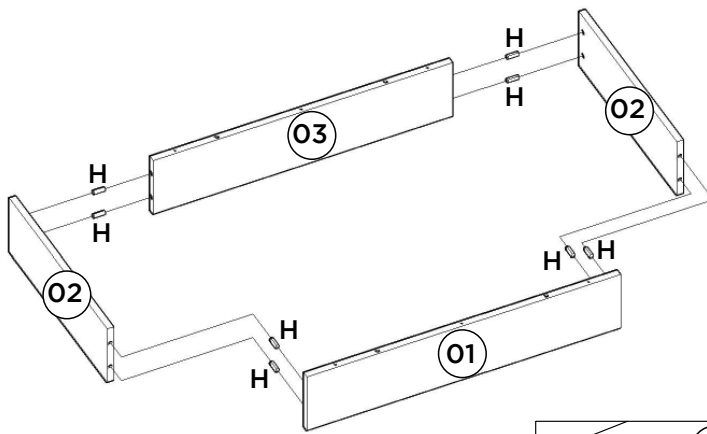

Utilizar o sachê de cola (AA) em todas as cavilhas (H) do produto.

Con el pegamento sobre (AA) en todos los pernos (H) producto.

Use the glue sachet (AA) on all the pegs (H) of the product.

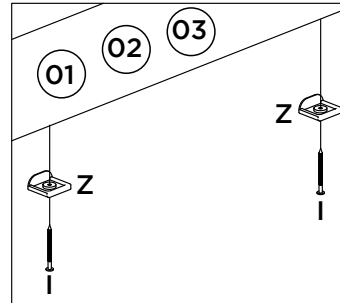
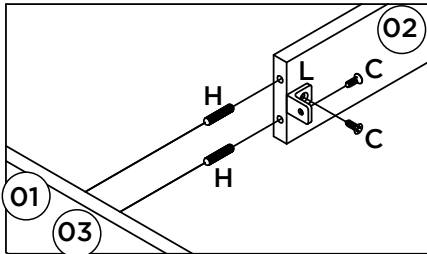

2º

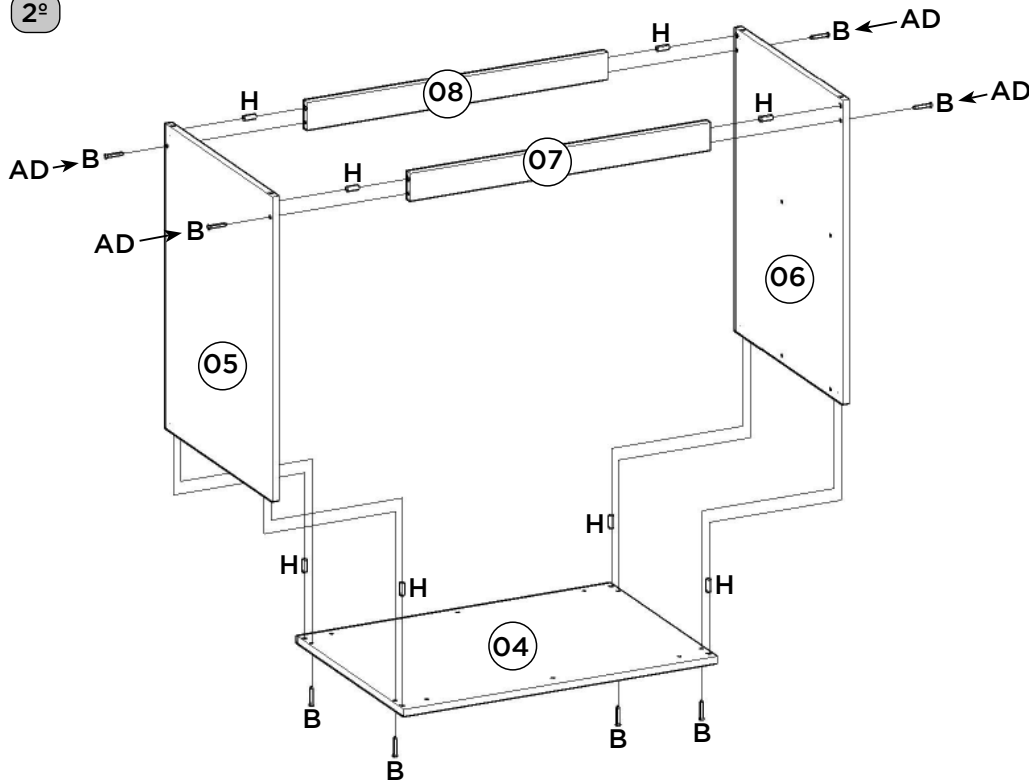
**OPCIONAL:**

O944-121 Kit Pé Cônico 145mm (vendido separadamente). Caso opte em colocar pé no produto, utilizar as pré-furações que possui na Base e fixá-lo com o Parafuso que consta no Kit.

OPCIONAL:

O944-121 Kit Pie Cónico 145mm (se vende por separado). Si opta por colocar pie en el producto, utilizar las pre-huracuras que tenga en la Base y fijarlo con el Tornillo que consta en el Kit.

OPTIONAL:

O944-121 Tapered Foot Kit 145mm (sold separately). If you choose to put foot in the product, use the pre-drillings in the Base and fix it with the Screw included in the Kit.

3º

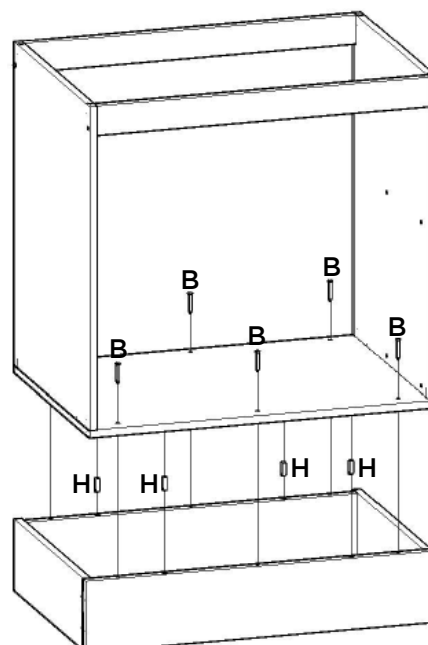

4°

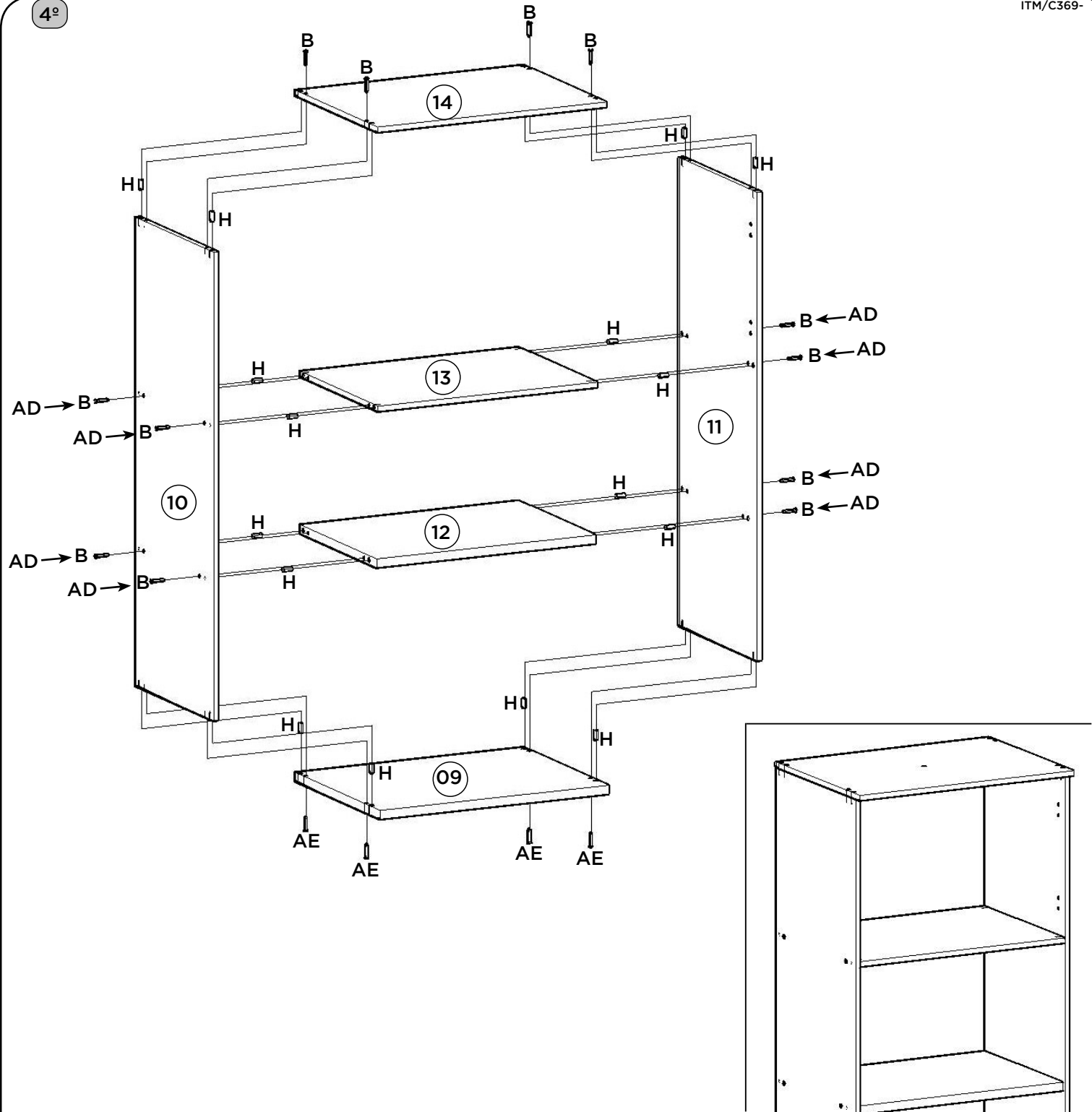

5°

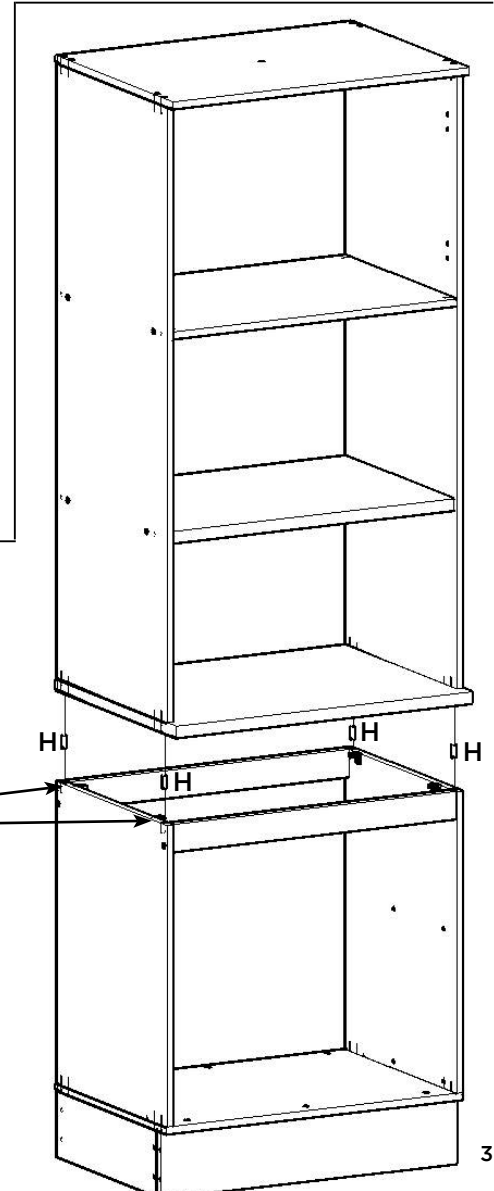
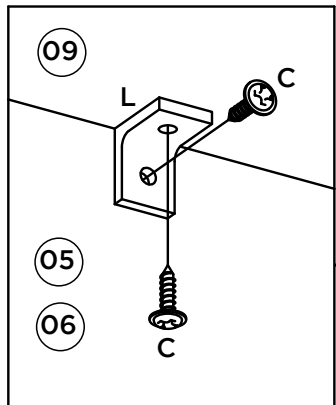

ATENÇÃO: Por questão de segurança, recomendamos a não utilização dos Fundos (16 e 17) caso o espaço seja utilizado por forno elétrico ou forno embutido, dessa forma, haverá melhor propagação do calor, evitando danos em seu móvel.

ATENCIÓN: Por razones de seguridad, recomendamos la no utilización de los Fondos (16 y 17) en caso de que el espacio sea utilizado por horno eléctrico o horno embutido, de esa forma, habrá mejor propagación del calor, evitando daños en su mueble.

WARNING: For safety reasons, we recommend that you do not use the bottoms (16 and 17) if the space is used by an electric oven or built-in oven, in this way, there will be better propagation of the heat, avoiding damage to your furniture.

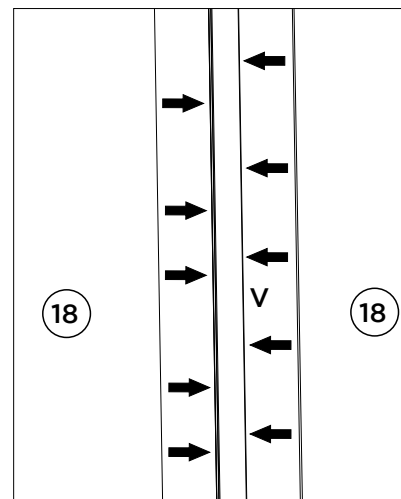
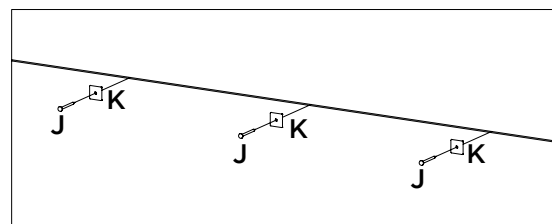
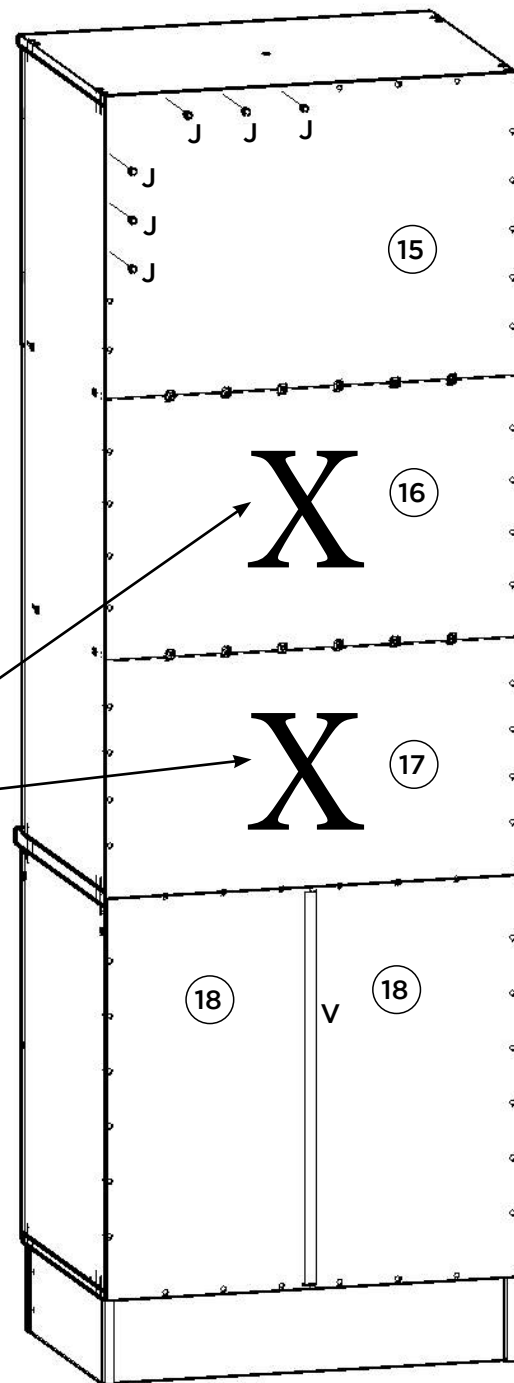

7°

Opção Suspensa

Opción suspendida

Suspended Option

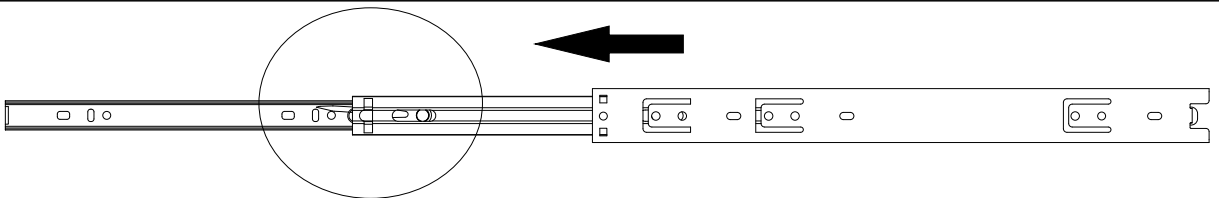
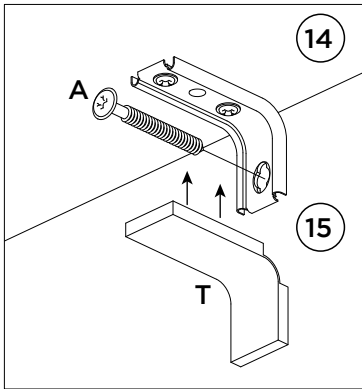
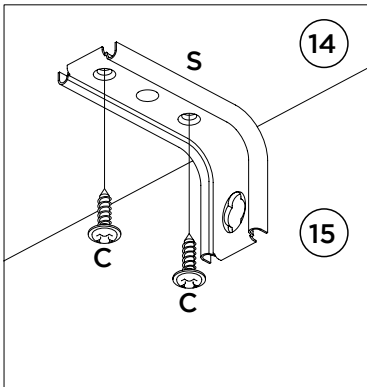
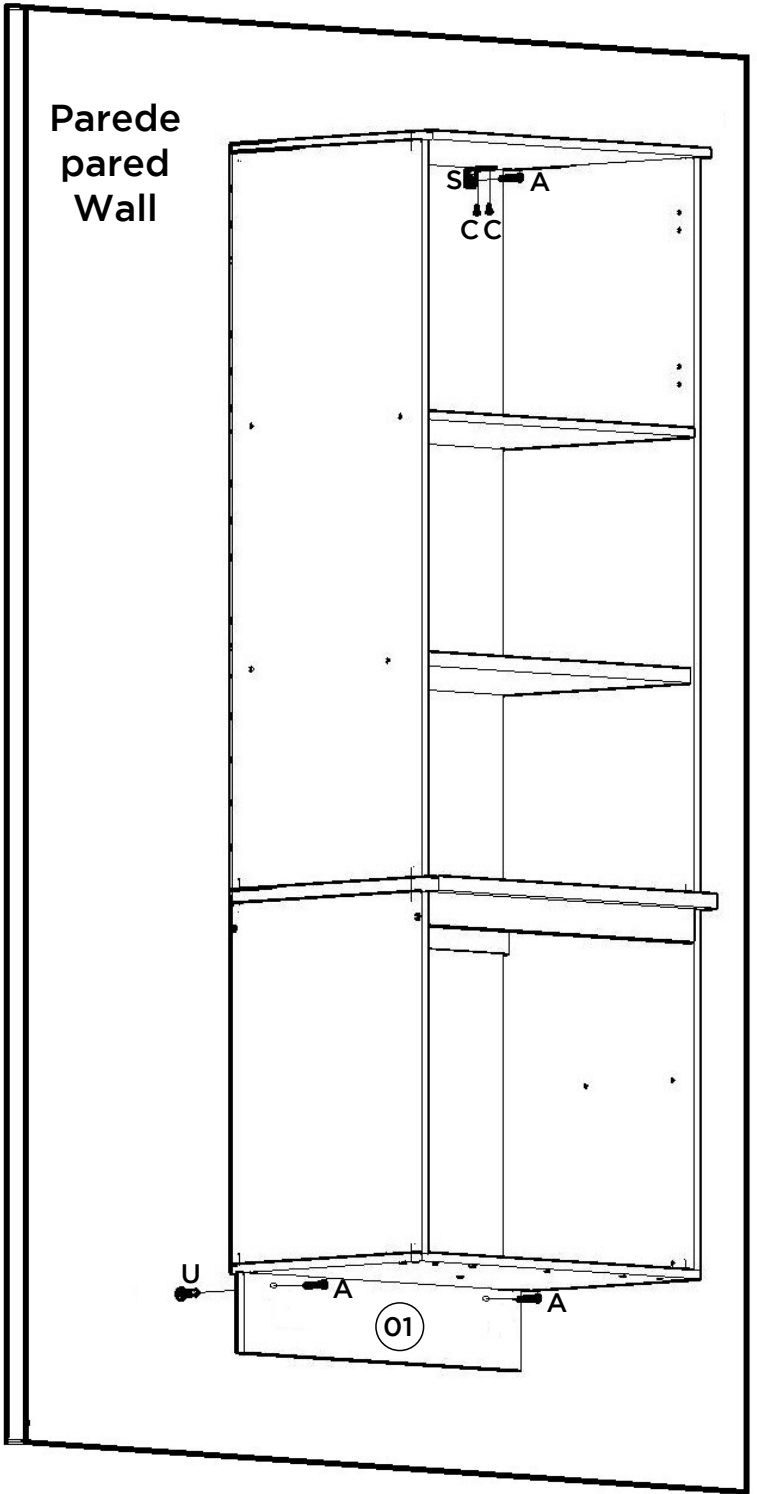

Para a desmontagem da correia siga a instrução ao lado.

Para el desmontaje seguimiento de diapositivas la instrucción siguiente a.

For the dismount of the sliding onem follows the instruction aside.

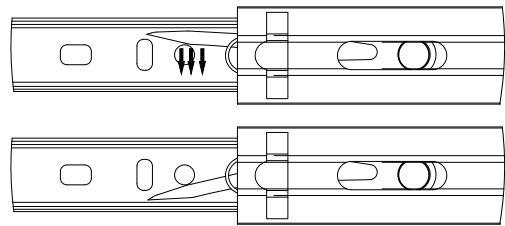

Fixar as correias nessas furações
Fijar las diapositivas de estos agujeros
Fix slides in these drillings

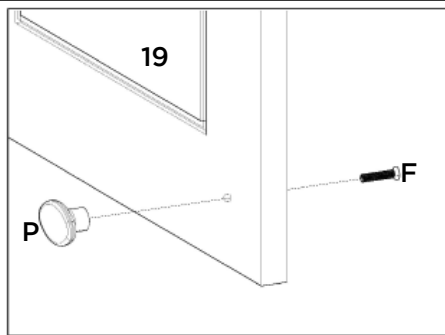

Para colocação dos puxadores, é necessário fazer a furação passante, com Broca de 5mm.

Para la colocación de las asas, es necesario perforar a través, con una broca de 5mm.

To place the handles is necessary to make the through hole, drill 5mm.

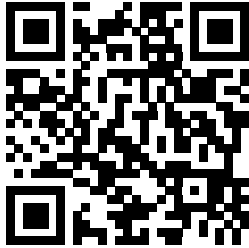

Vídeo: Instalar e regular Dobradiças

Video: Instale y ajuste las bisagras

Video: Install and adjust hinges

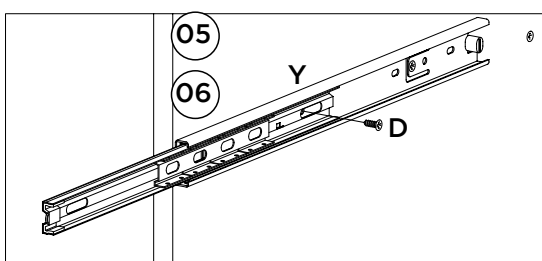
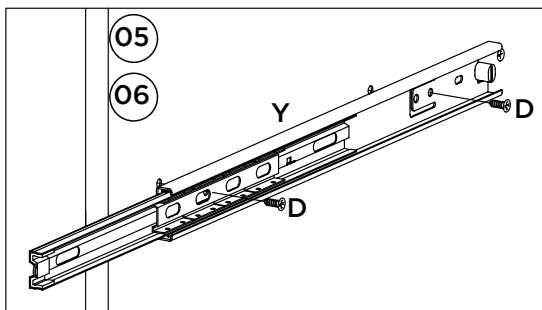
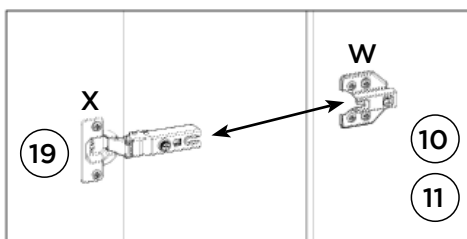
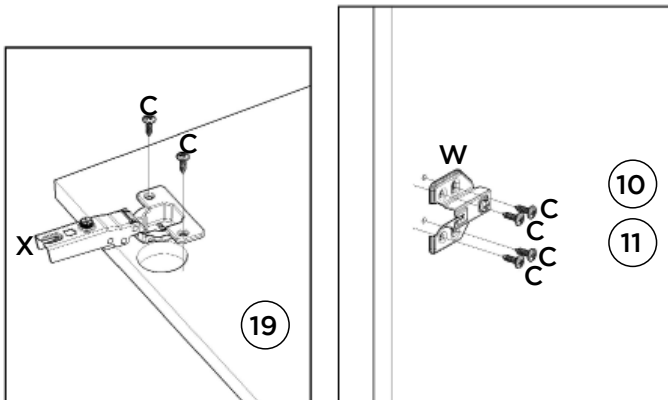
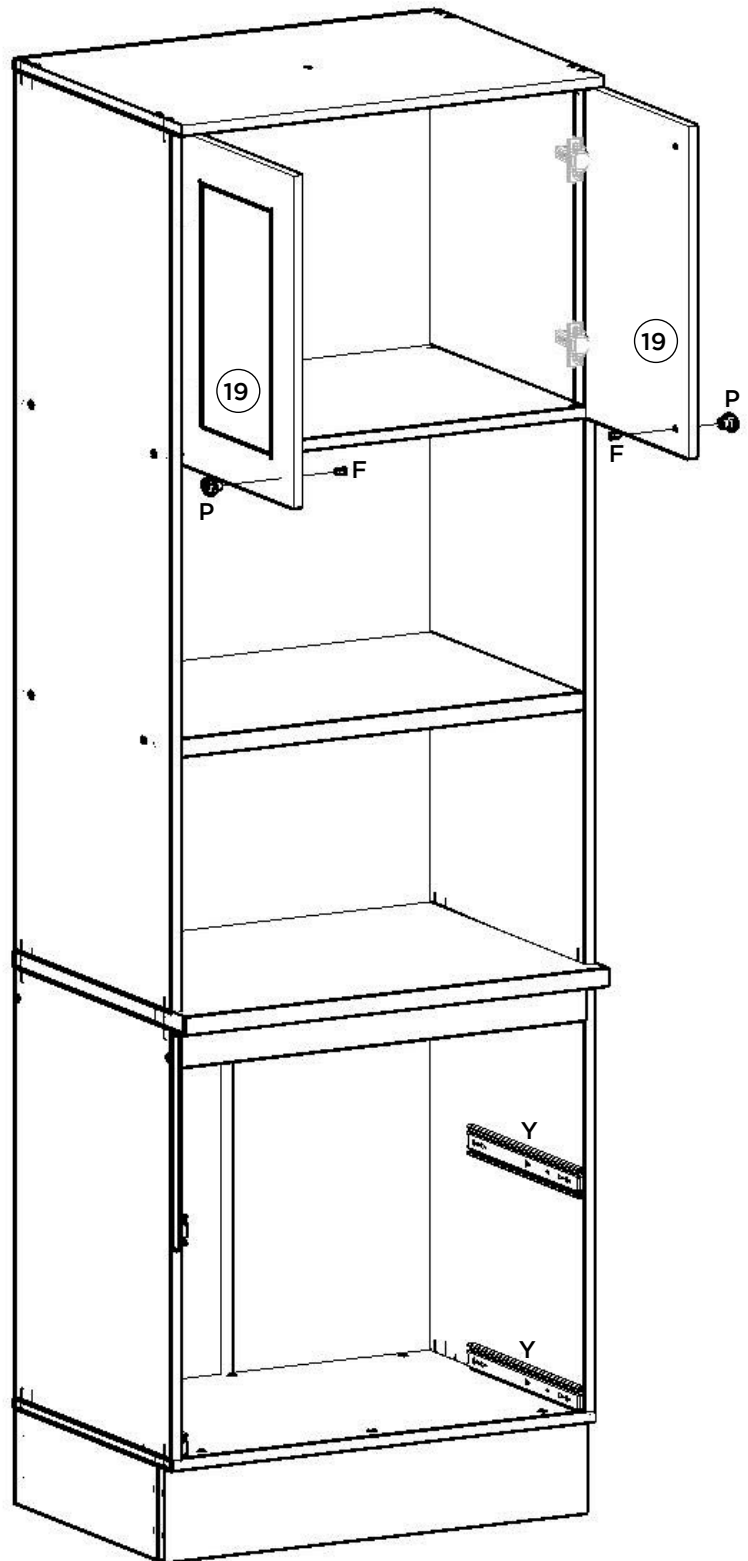

Vídeo: Dicas para fixar a Corrediça

Video: Consejos para arreglar la diapositiva

Video: Tips for Fixing the Slide



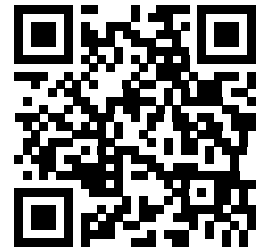
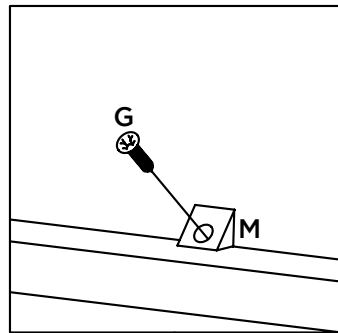
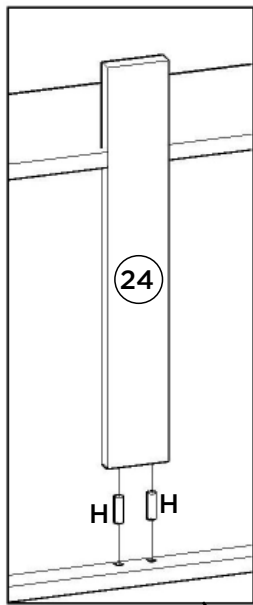
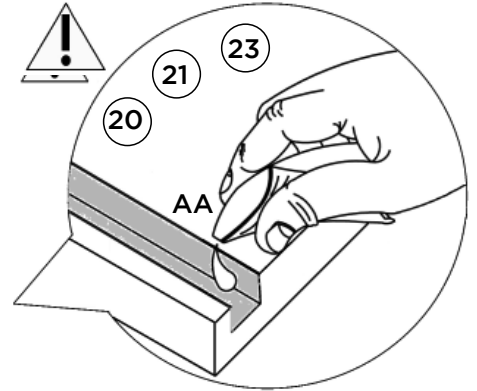
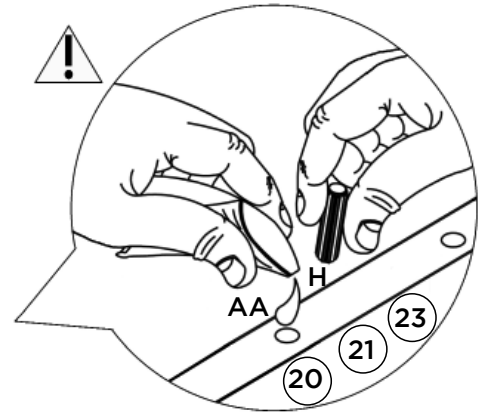
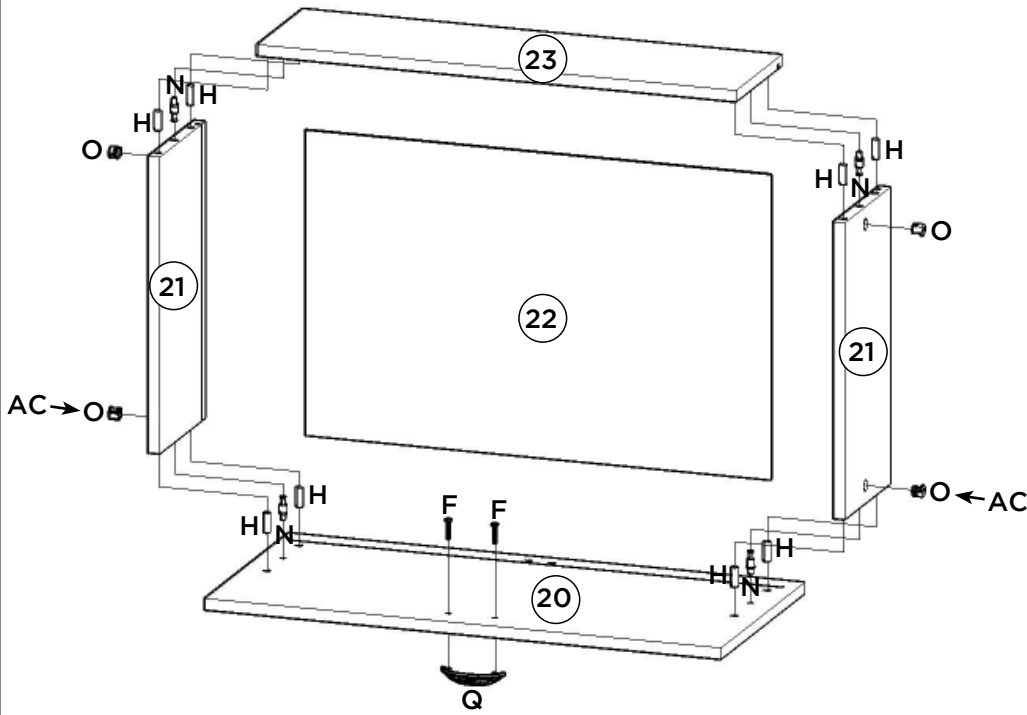

Vídeo: Dicas para fixar o Minifix





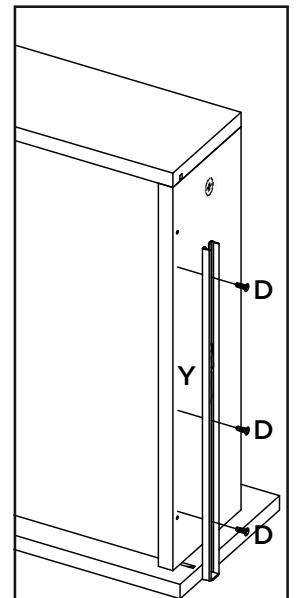
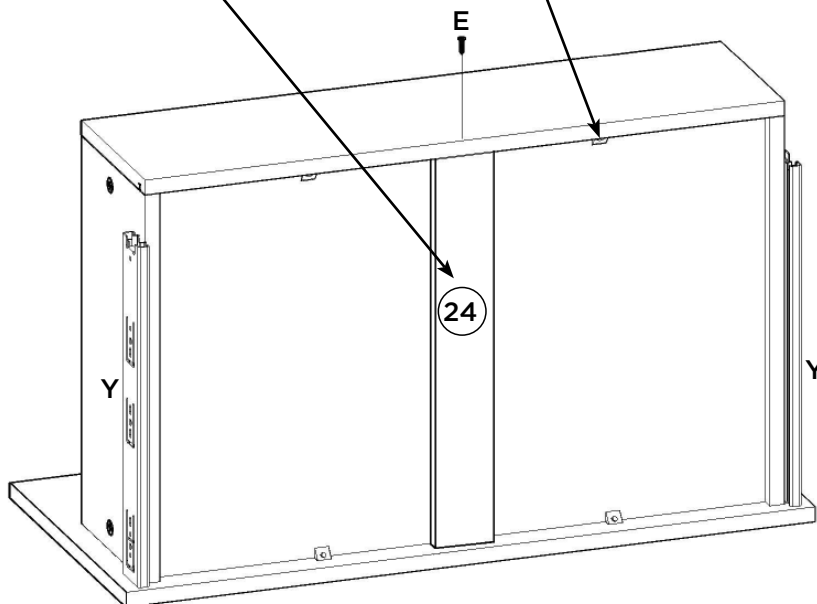









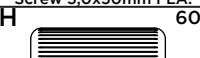
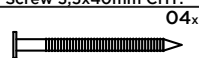
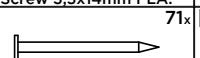
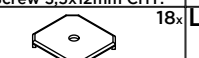

Video: Consejos para arreglar Minifix

Video: Tips for Fixing Minifix

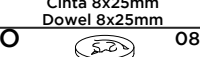

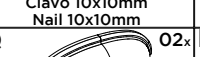
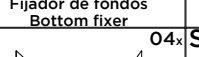
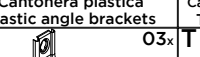
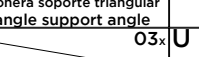
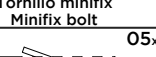
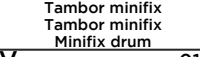
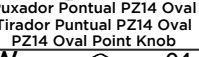
Item	Caixa Caja Box	Qtd Ctd Qty	Descrição Descripción Description	Medidas (mm) Dimensions (mm) Size (measurements) (mm)
01	1/3	01	Rodapé Frontal Frente pie de página Front Footer	715x145x15
02	2/3	02	Rodapé Lateral Pie de página Side Side Footer	450x145x15
03	1/3	01	Rodapé Traseiro Pie de página trasera Rear Footer	683x145x15
04	2/3	01	Base Base Base	715x490x15
05	1/3	01	Lateral Esquerda Inferior Lateral Izquierda Inferior Left Side Lower	660x490x15
06	1/3	01	Lateral Direita Inferior Lateral Derecha Inferior Right Side Bottom	660x490x15
07	1/3	01	Travessa frontal Travesaño frontal Front crossbar	684x60x15
08	1/3	01	Travessa traseira Travesaño trasero Rear bumper	684x60x15
09	3/3	01	Tampo 25mm Tapa 25mm 25mm Top	715x533x25
10	1/3	01	Lateral Esquerda Superior Lateral Izquierda Superior Upper Left Side	1345x490x15
11	1/3	01	Lateral Direita Superior Lateral Derecha Superior Right Side Superior	1345x490x15
12	2/3	01	Prateleira 25mm Estantería 25mm Shelf 25mm	684x480x25
13	2/3	01	Prateleira Central Estantería central Central Shelf	684x490x15
14	2/3	01	Tampo Tapa Top	715x517x15
15	2/3	01	Fundo Superior Fondo superior Superior background	708x272x3
16	2/3	01	Fundo Central Maior Fondo Central Mayor Major Central Fund	708x447x3
17	2/3	01	Fundo central Fondo central Central fund	708x405x3
18	2/3	02	Fundo Cru Fondo Crudo Raw Background	687x353x3
19	1/3	02	Porta Menor Puerto Menor Less door	508x354x15
20	1/3	02	Frente de gaveta Frente de cajón Front of drawer	711x330x15
21	1/3 e 2/3	04	Lado de Gaveta Lado del cajón Drawer Side	400x180x15
22	1/3	02	Fundo de gaveta Fondo de cajón Bottom of drawer	640x411x3
23	2/3	02	Ripa de trás Malla detrás Rear lath	659x180x15
24	2/3	02	Ripa Estrutural Gaveta Ripa Estructural Cajón Drawer Structural Clamp	400x60x15

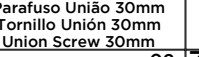
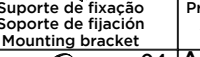
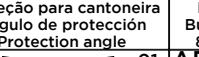
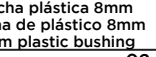
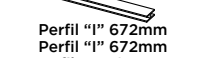
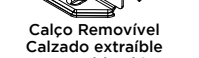
Ferragens | Herrajes | Hardware

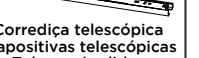
A 05x  Parafuso 5,0x50mm FLA. Tornillo 5,0x50mm FLA. Screw 5,0x50mm FLA.	B 26x  Parafuso 3,5x40mm CHT. Tornillo 3,5x40mm CHT. Screw 3,5x40mm CHT.	C 46x  Parafuso 3,5x14mm FLA. Tornillo 3,5x14mm FLA. Screw 3,5x14mm FLA.	D 24x  Parafuso 3,5x12mm CHT. Tornillo 3,5x12mm CHT. Screw 3,5x12mm CHT.	E 02x  Parafuso 3,0x30mm CHT. Tornillo 3,0x30mm CHT. Screw 3,0x30mm CHT.	F 06x  Parafuso M4x20mm CHT. ZB Tornillo M4x20mm CHT. ZB Screw M4x20mm CHT. ZB	G 08x  Parafuso 3,0x16mm CHT. Tornillo 3,0x16mm CHT. Screw 3,0x16mm CHT.
H 60x  Cavilha 8x25mm Cinta 8x25mm Dowel 8x25mm	I 04x  Prego 12x12mm Anelado Clavo 12x12mm Anillado Ringed Nails 12x12mm	J 71x  Prego 10x10mm Clavo 10x10mm Nail 10x10mm	K 18x  Fixador de fundos Fijador de fondos Bottom fixer	L 08x  Cantoneira plástica Cantonera plástica Plastic angle brackets	M 08x  Cantoneira suporte triangular Cantonera soporte triangular Triangle support angle	N 08x  Parafuso minifix Tornillo minifix Minifix bolt
O 08x  Tambor minifix Tambor minifix Minifix drum	P 02x  Puxador Pontual PZ14 Oval Tirador Puntual PZ14 Oval Ringed Knob	Q 02x  Puxador Concha Tirador Concha Shell Handle	R 04x  Parafuso União 30mm Tornillo Unión 30mm Union Screw 30mm	S 03x  Suporte de fixação Soporte de fijación Mounting bracket	T 03x  Proteção para cantoneira Ángulo de protección Protection angle	U 05x  Buchta plástica 8mm Bucha de plástico 8mm 8mm plastic bushing
V 01x  Perfil "I" 672mm Profile "I" 672mm	W 04x  Calço Removível Calzado extraíble Removable Shim	X 04x  Dobradica SlideOn Baixa Amortecedor 35mm Bisagra SlideOn Baja Amortiguador 35mm Low SlideOn Hinge 35mm Shock Absorber	Y 02x  Corredica telescópica Diapositivas telescópicas Telescopic slides	Z 04x  Sapata "L" 16x20mm Zapata "L" 16x20mm "L" shoe 16x20mm	AA 01x  Sachê de cola Bolsa de pegamento Glue bag	AB 02x  Giz de correção Tiza de corrección Chalk of correction
AC 04x  Adesivo tampa parafuso 17mm Adhesivo tapón de tornillo 17mm Bolt cover adhesive 17mm	AD 20x  Adesivo tampa parafuso 10mm Adhesivo tapón de tornillo 10mm Bolt cover adhesive 10mm	AE 04x  Parafuso 4,5x50mm CHT. Tornillo 4,5x50mm CHT. Screw 4,5x50mm CHT.	AF 01x  Etiqueta resinada Henn Etiqueta resinada Henn Henn resin label			

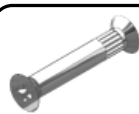

O parafuso (R) deve ser usada somente quando este módulo for acoplado a outro módulo componível Henn.

RECOMENDAÇÃO

Para fixar o móvel na parede usar o suporte de fixação (S), o parafuso 3,5x14mm FLA (C), a Bucha 8mm (U) e o parafuso 5,0x50mm FLA (A).



El tornillo (R) se debe utilizar sólo cuando el módulo está conectado a otro módulo componible Henn.

RECOMENDACIÓN

Para conectar el móvil a la pared con el soporte (S), tornillo 3,5 x14mm FLA (C), el casquillo de 8 mm (U) y el 5,0 x50mm tornillo FLA (A).



The screw (R) should be used only when this module is attached to another Henn modular element.

RECOMMENDATION

To fix the furniture to the wall use the mounting bracket (S), the 3.5x14mm FLA (C) screw, the 8mm bushing (U) and the 5.0x50mm FLA (A).