

ASSEMBLY INSTRUCTIONS MANUAL DE MONTAGEM / INSTRUCCIONES DE ARMADO

CAMPANELE BASE CABINET 2 DOORS 3 DRAWERS 47 1/4"
BALCÃO 2 PORTAS 3 GAVETAS 1200MM CAMPANELE
GABINETE 2 PUERTAS 3 CAJONES 1200MM CAMPANELE

Reference | Revisé
Referência | Revisão
Referencia | Revisión
200039 | **02**

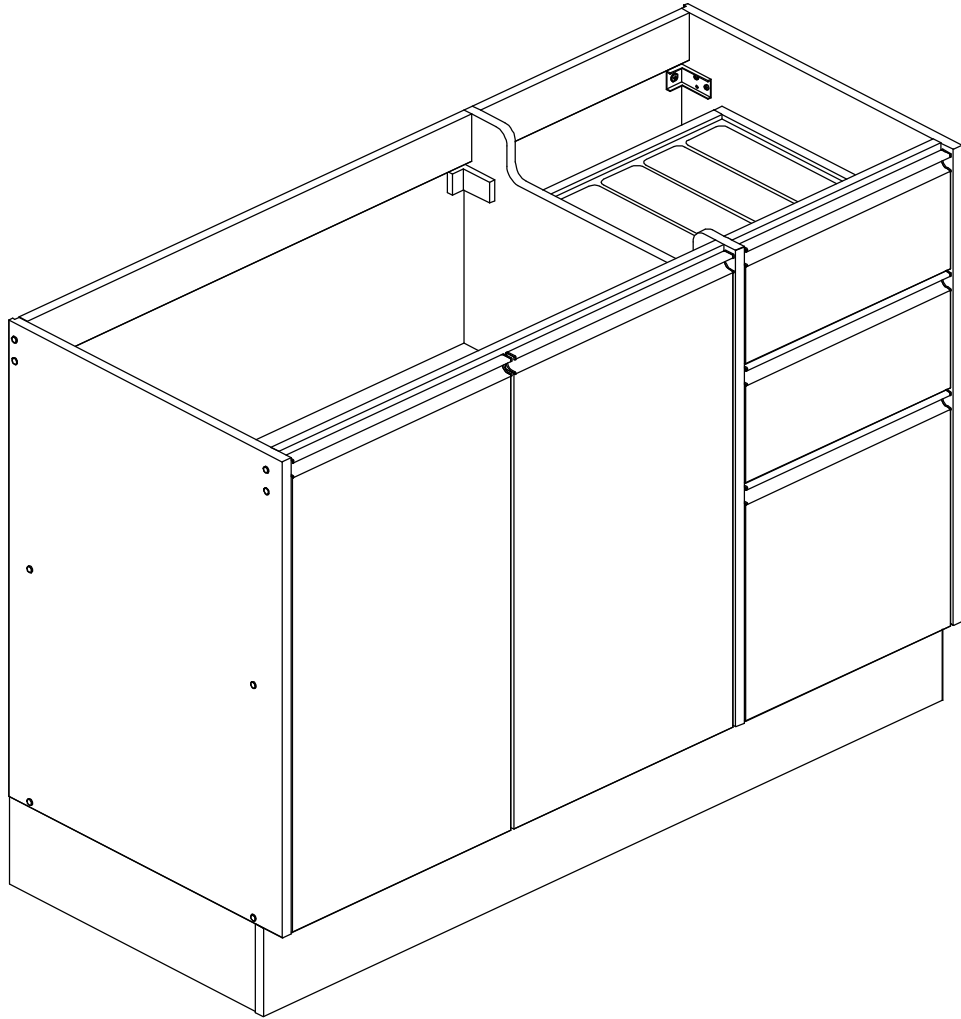

YOU WILL NEED / VOCÊ VAI PRECISAR DE / USTED NECESITARÁ

Tools not supplied / Ferramentas não fornecidas / Herramientas no incluidas

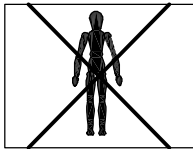

1 Person
1 Pessoa
1 Persona

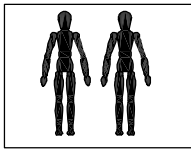

2 People
2 Pessoas
2 Personas

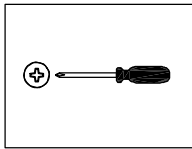

Screwdriver Phillips
Chave Phillips
Destornillador cruz

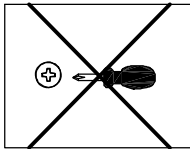

Small screwdriver Phillips
Chave Phillips Menor
Destornillador cruz menor

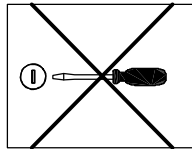

Screwdriver slotted
Chave fenda
Destornillador plano

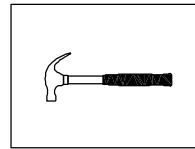

Hammer
Martelo
Martillo

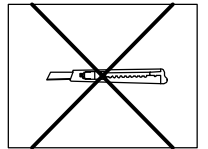

Stylet
Estilete
Estilete

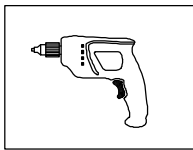

Drill machine
Furadeira
Taladro

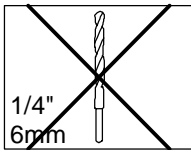

Drill bit
Broca
Taladro

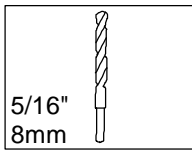

Drill bit
Broca
Taladro

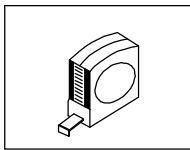

Measuring tape
Trena
Cinta de medición

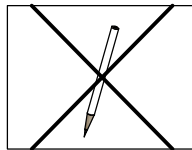

Pencil
Lápis
Lápis

NOTES: The separation of the accessories before you start the assembly will facilitate the same. In case of doubt on the size of the screws and bolts, use the ruler to bottom of page 3.

NOTAS: A separação dos acessórios antes de iniciar a montagem facilitará a mesma. Em caso de dúvida no tamanho dos parafusos e cavilhas, utilize a régua ao final da página 3.

NOTAS: La separación de los accesorios antes de comenzar el armado facilitará el mismo. En caso de duda sobre el tamaño de los tornillos y taquetes, utilice la regla al pie de página 3.

MAXIMUM RECOMMENDED WEIGHT
BEING THIS EVENLY DISTRIBUTED

PESO MÁXIMO RECOMENDADO SENDO
ESTE DISTRIBUÍDO UNIFORMEMENTE

PESO MÁXIMO RECOMENDADO SIENDO
ESTE UNIFORMEMENTE DISTRIBUIDO

	LB	KG
A	22	10

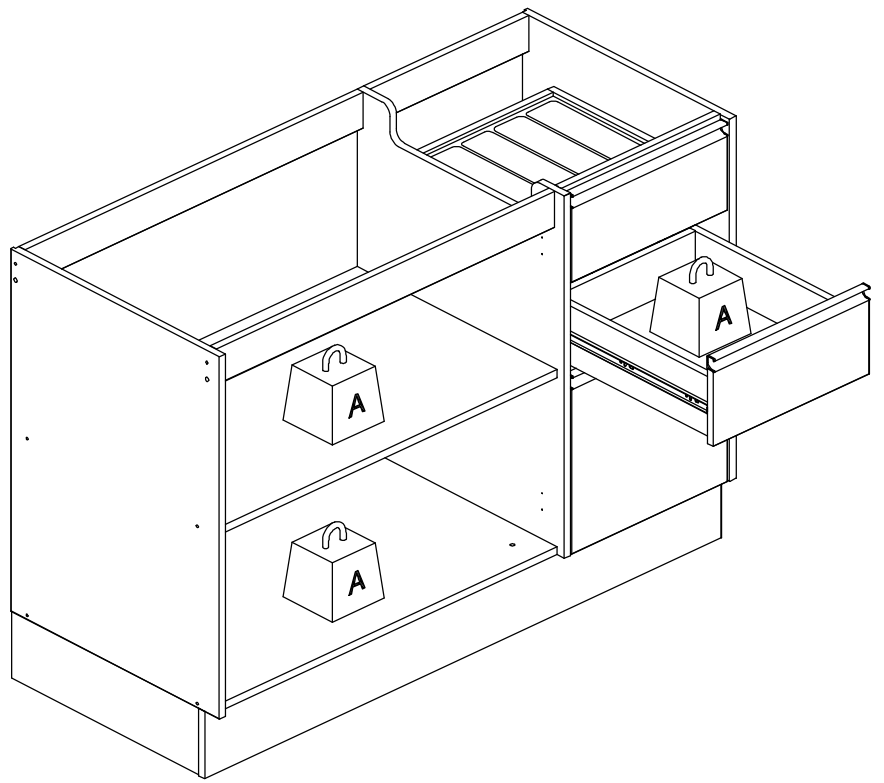





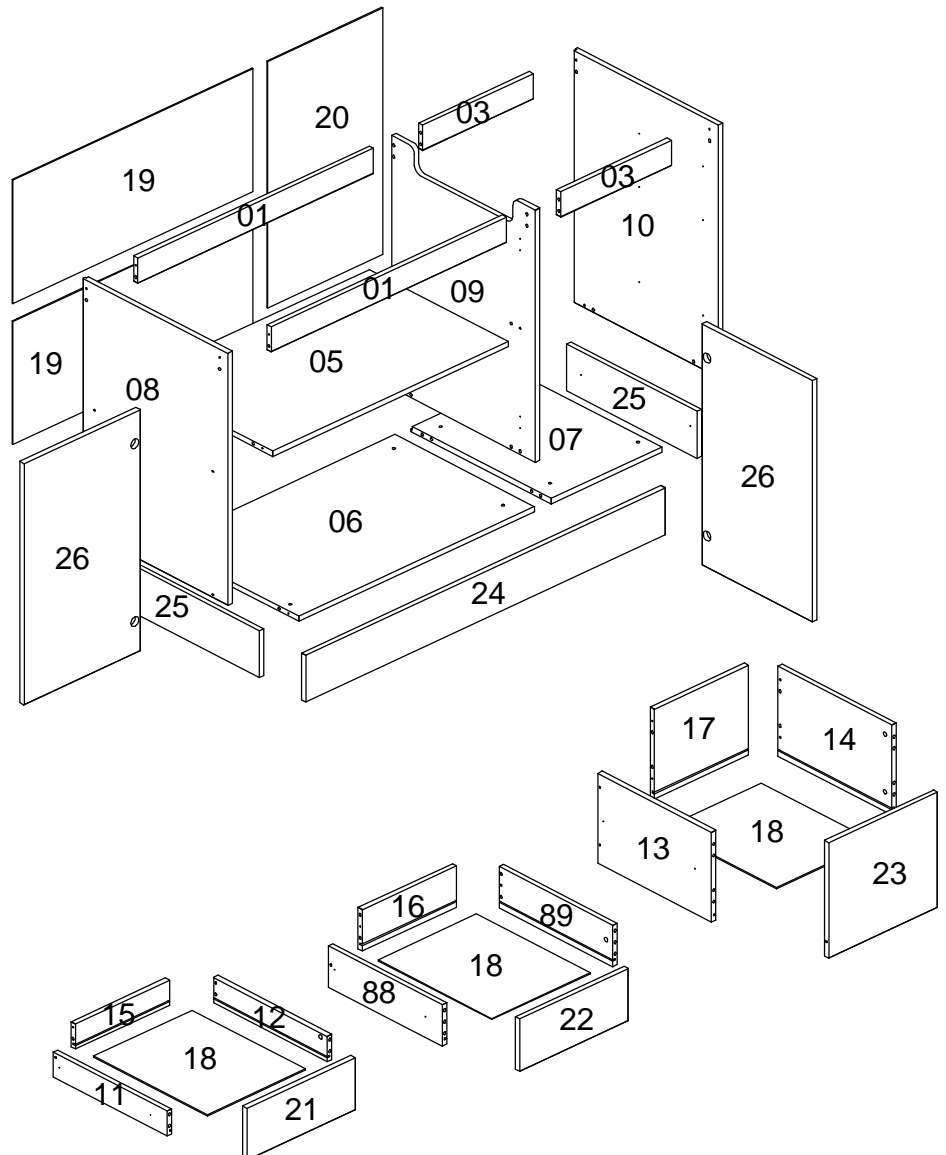



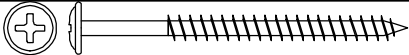

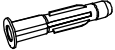

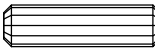
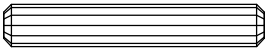

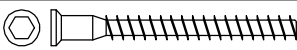

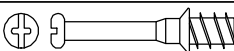
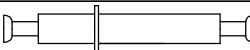

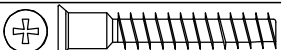

Nº	Measures Inches	Medidas cm	Qty./Qtd.
01	2 3/4 x 30 7/8 x 5/8	7 x 78,5 x 1,5	2
03	2 3/4 x 14 1/2 x 5/8	7 x 36,9 x 1,5	2
05	19 1/4 x 30 7/8 x 5/8	48,9 x 78,5 x 1,5	1
06	19 3/8 x 30 7/8 x 5/8	49,3 x 78,5 x 1,5	1
07	19 3/8 x 14 1/2 x 5/8	49,3 x 36,9 x 1,5	1
08	20 1/8 x 27 1/2 x 5/8	51 x 70 x 1,5	1
09	19 7/8 x 27 1/2 x 5/8	50,6 x 70 x 1,5	1
10	20 1/8 x 27 1/2 x 5/8	51 x 70 x 1,5	1
11	15 3/4 x 2 3/4 x 5/8	40 x 7 x 1,5	1
12	15 3/4 x 2 3/4 x 5/8	40 x 7 x 1,5	1
13	15 3/4 x 9 7/8 x 5/8	40 x 25 x 1,5	1
14	15 3/4 x 9 7/8 x 5/8	40 x 25 x 1,5	1
15	12 3/8 x 2 3/4 x 5/8	31,4 x 7 x 1,5	1
16	12 3/8 x 4 1/2 x 5/8	31,4 x 11,5 x 1,5	1
17	12 3/8 x 9 7/8 x 5/8	31,4 x 25 x 1,5	1
18	12 7/8 x 15 3/4 x 1/8	32,8 x 39,9 x 0,3	3
19	31 1/2 x 13 1/2 x 1/8	80 x 34,2 x 0,3	2
20	26 7/8 x 15 1/8 x 1/8	68,4 x 38,3 x 0,3	1
21	14 1/4 x 5 3/4 x 5/8	36,3 x 14,6 x 1,5	1
22	14 1/4 x 5 3/4 x 5/8	36,3 x 14,6 x 1,5	1
23	14 1/4 x 12 5/8 x 5/8	36,3 x 32,2 x 1,5	1
24	47 1/4 x 5 1/8 x 5/8	119,9 x 13 x 1,5	1
25	18 1/8 x 5 1/8 x 5/8	45,9 x 13 x 1,5	2
26	15 1/4 x 26 3/8 x 5/8	38,8 x 67 x 1,5	2
88	15 3/4 x 4 1/2 x 5/8	40 x 11,5 x 1,5	1
89	15 3/4 x 4 1/2 x 5/8	40 x 11,5 x 1,5	1

PARTS IDENTIFICATION
IDENTIFICAÇÃO DAS PEÇAS / IDENTIFICACIÓN DE LAS PIEZAS

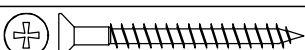
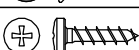

IDENTIFICATION OF ACCESSORIES IDENTIFICAÇÃO DOS ACESSÓRIOS/ IDENTIFICACIÓN DE ACCESORIOS

A		Flanged head screw / Parafuso flangeado / Tornillo de cabeza flangeada	5,0x60 mm	3
A1		Glue / Cola / Pegamento	13 g	1
B3		Bushing / Bucha expansiva / Tapón	8x50 mm	3
C1		Metal claw / Garra de metal / Garra metal	-	8
E		Wooden dowel / Cavilha / Taquete	8x30 mm	32
F		Wooden dowel / Cavilha / Taquete	8x50 mm	4
F13		Handle / Puxador Perfil 700T / Tirador	363 mm	3
F14		Handle / Puxador Perfil 700T / Tirador	387 mm	2
G		Structural screw / Parafuso estrutural / Tornillo estructural	5,0x50 mm	12
H		Allen key / Chave allen / Liave allen	3 mm	1
I		Structural screw cover/Tampa parafuso estrutural/Tapa tornillo estructural	-	10
J		Simple minifix screw / Haste minifix simples / Tornillo minifix simple	-	8
K		Double minifix screw / Haste minifix dupla / Tornillo minifix doble	60mm	4
L		Drum lock / Tambor minifix / Tambor minifix	12 mm	16
L1		Flat head screw / Parafuso chato / Tornillo de cabeza plana	7,0x40 mm	8
L3		Plastic Foot / Sapata / Pie Plástico	-	8
M		Bore patch adhesive / Tapa furo adesivo / Tapones adhesivo	-	16
M12		Metal hinge super high / Dobradiça super alta / Bisagra alta	35 mm	4
N4		Loop / Presilha / Presilla	-	8
N5		Support "L" / Suporte "L" / Soporte "L"	-	3
N6		Cover / Capa / Cubierta	-	2
O		Flat head screw / Parafuso chato / Tornillo de cabeza plana	4,5x45 mm	8
S		Pan head screw / Parafuso panela / Tornillo de pan	3,5x14 mm	77
T7		Cutlery divider / Divisor de Talheres / Divisor de cubiertos	384x314mm	1
V3		Telescopic slide / Corrediça telescópica / Corredera telescópica	400 mm	3
X6		Nail / Prego / Clavo	10 x 7	48
Z		Plastic hole plugs / Tapa furo plástico / Tapones plásticos	8 mm	4



PRE-ASSEMBLE
PRÉ-MONTAGEM / PRE ARMADO

01

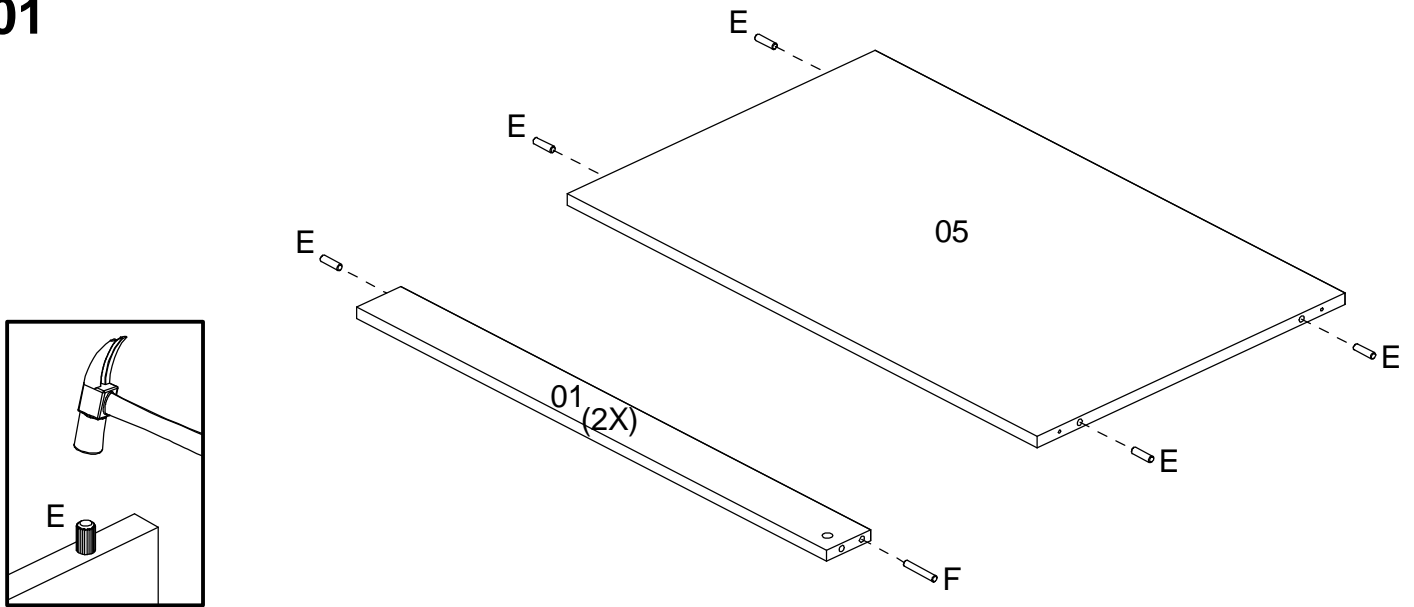

02

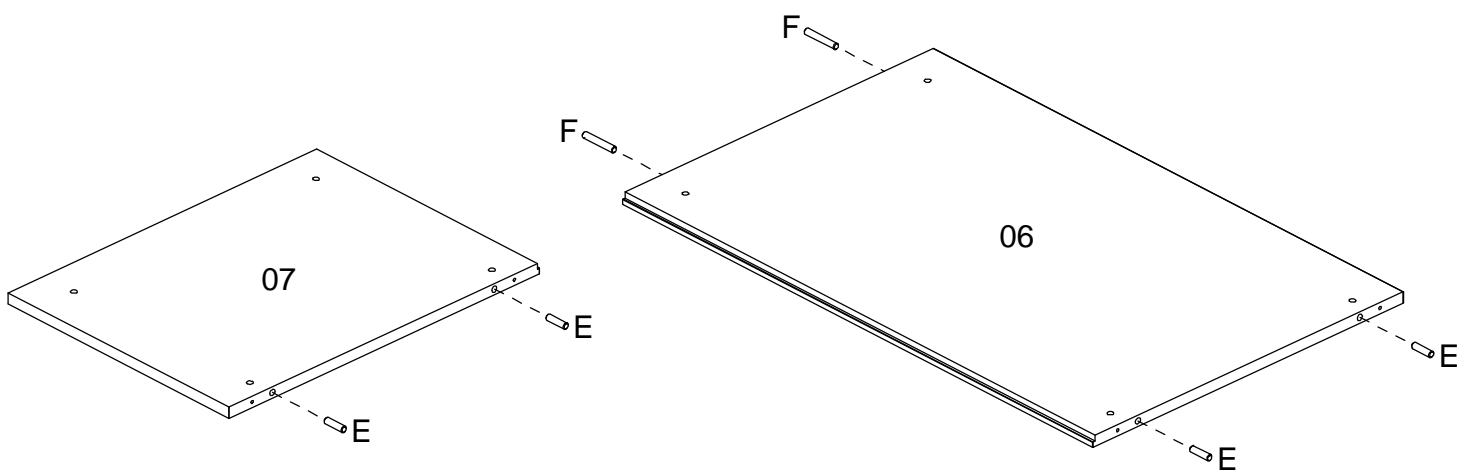

03

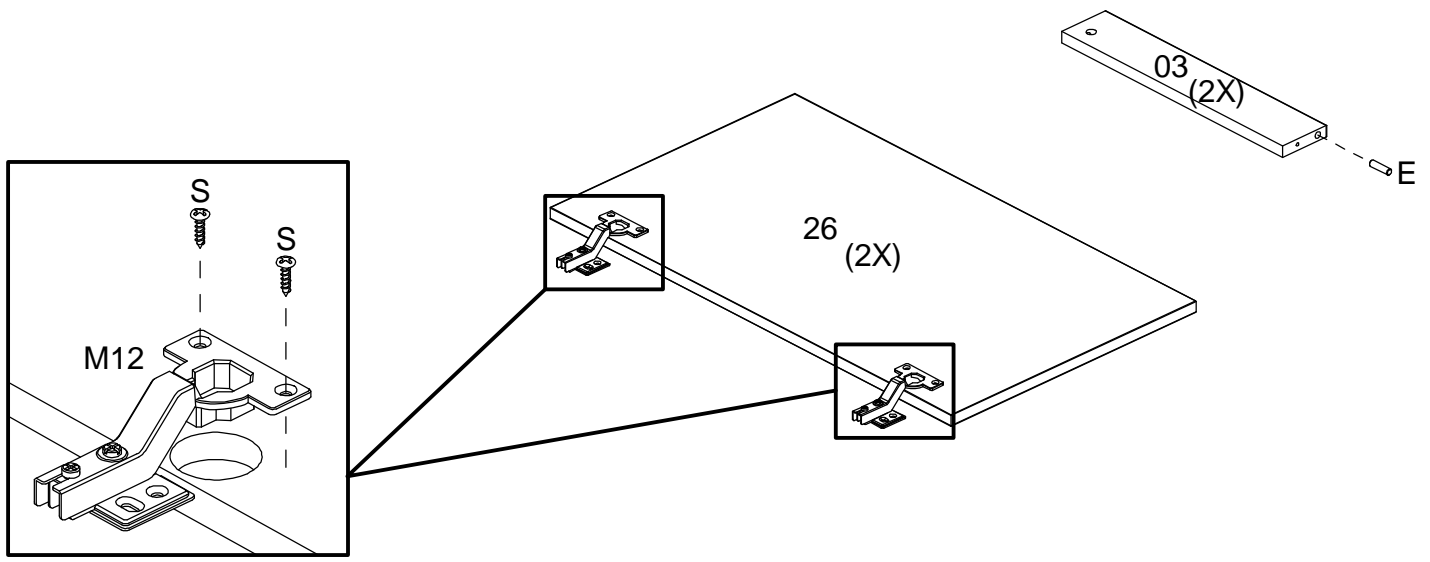

04

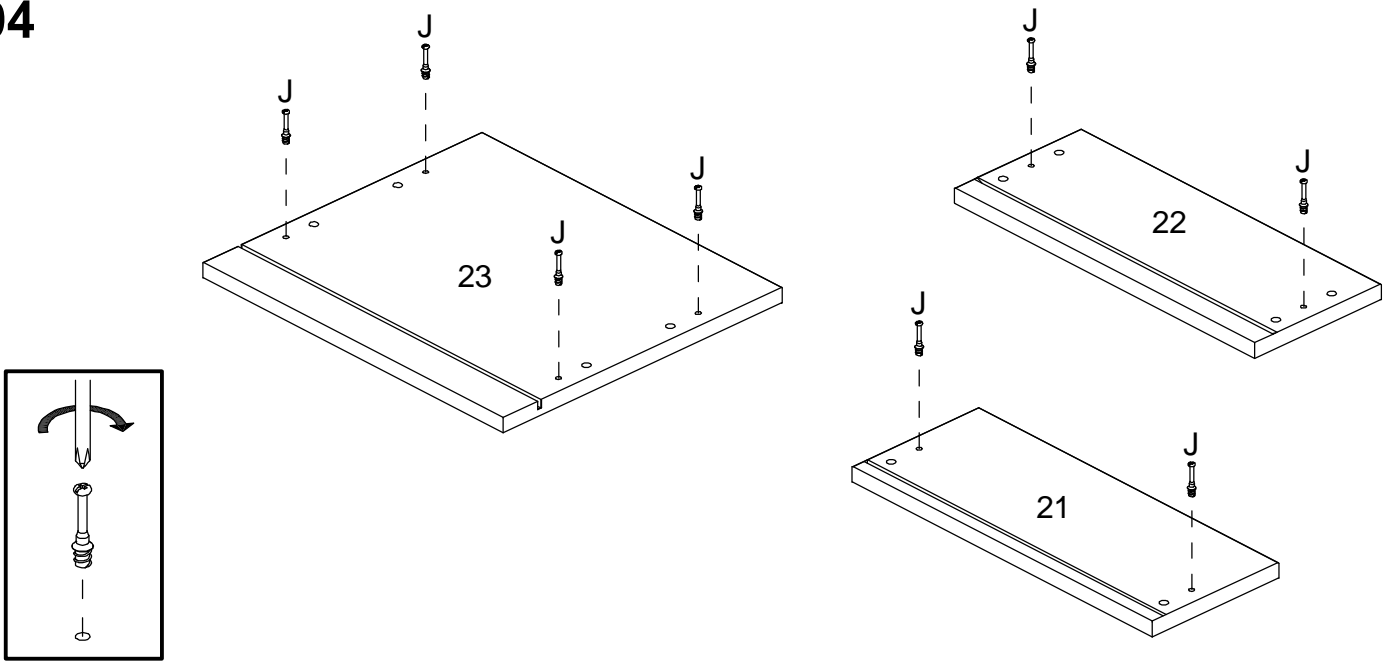

05

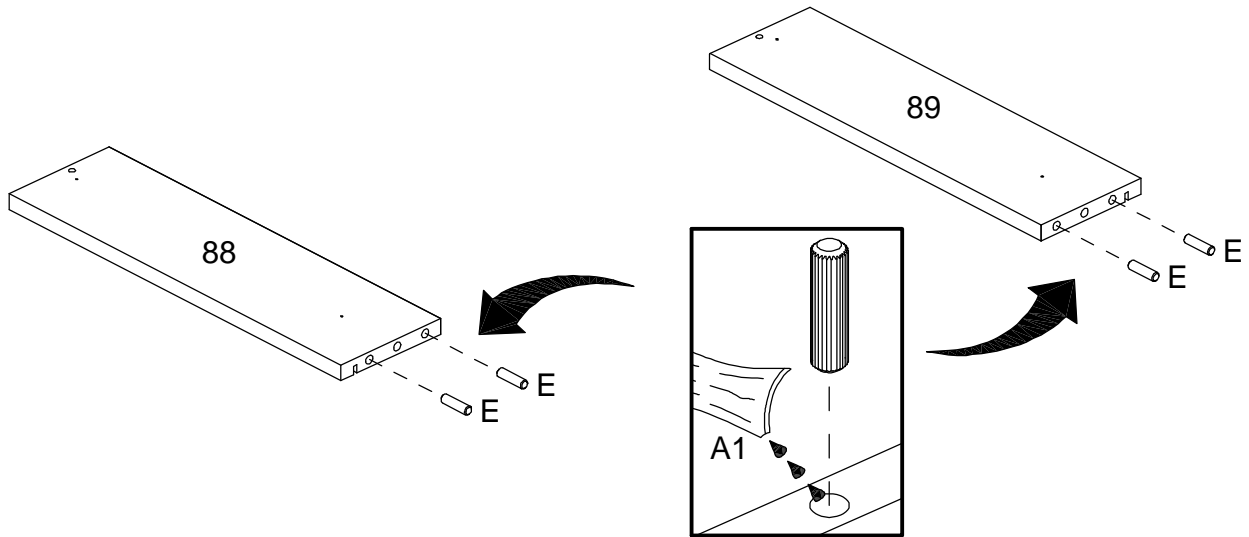

06

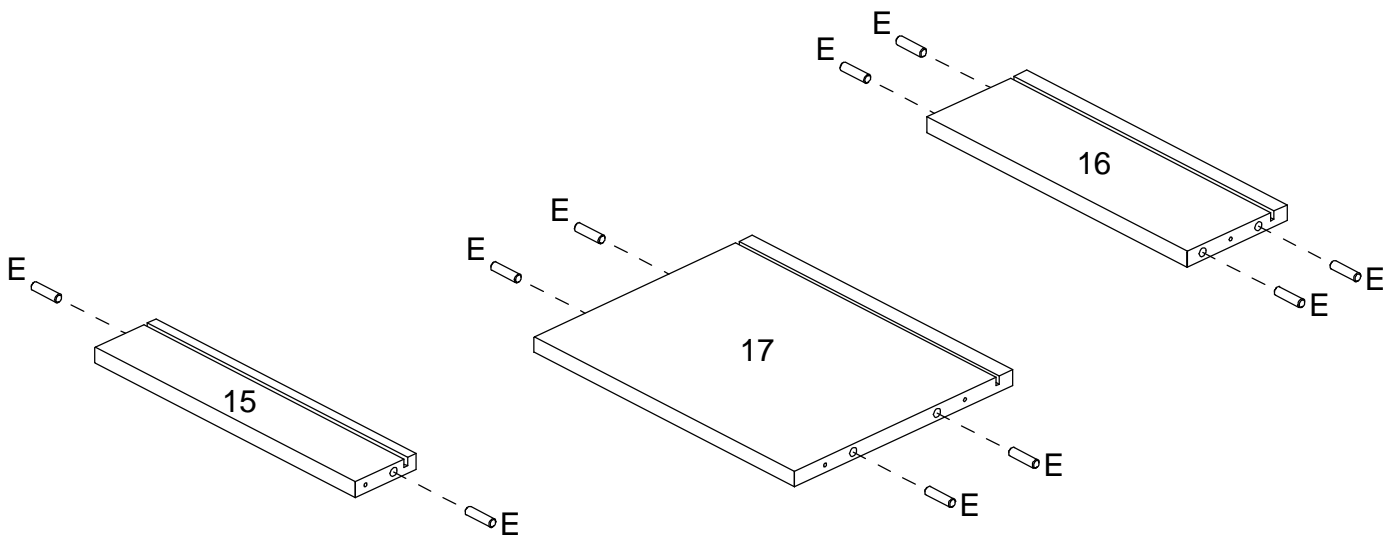

07

SEPARATE THE TWO PARTS OF THE METAL SLIDE TO THE ASSEMBLY FOLLOWING THE INSTRUCTIONS BELOW.
SEPARAR AS DUAS PARTES DA CORREDIÇA METÁLICA PARA A MONTAGEM SEGUINDO AS INSTRUÇÕES ABAIXO.
SEPARAR LAS DOS PARTES DE LA CORREDERA DE METAL PARA EL ARMADO Y SEGUIR A LAS INSTRUCCIONES ABAJO.

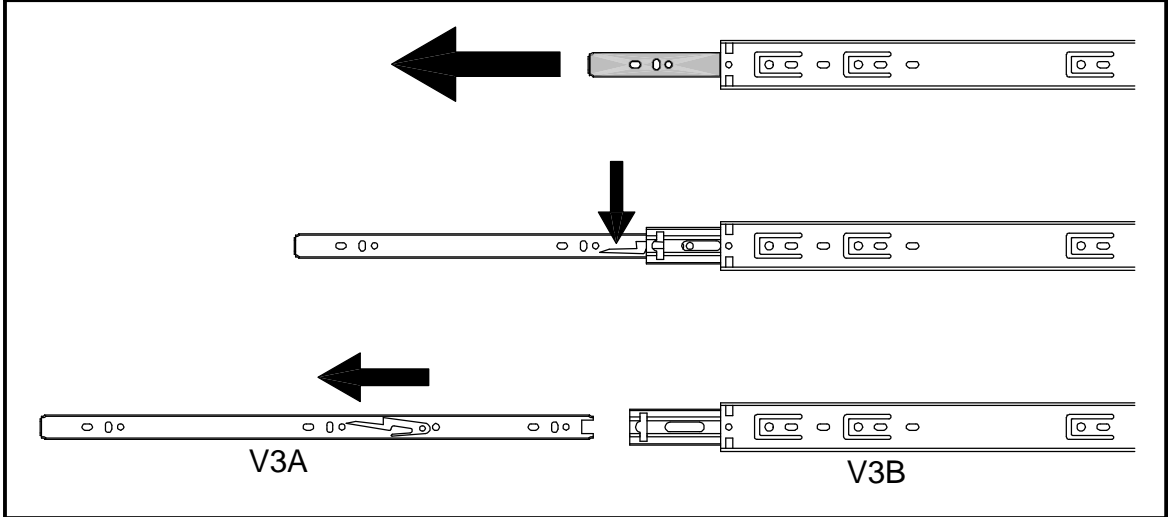

08

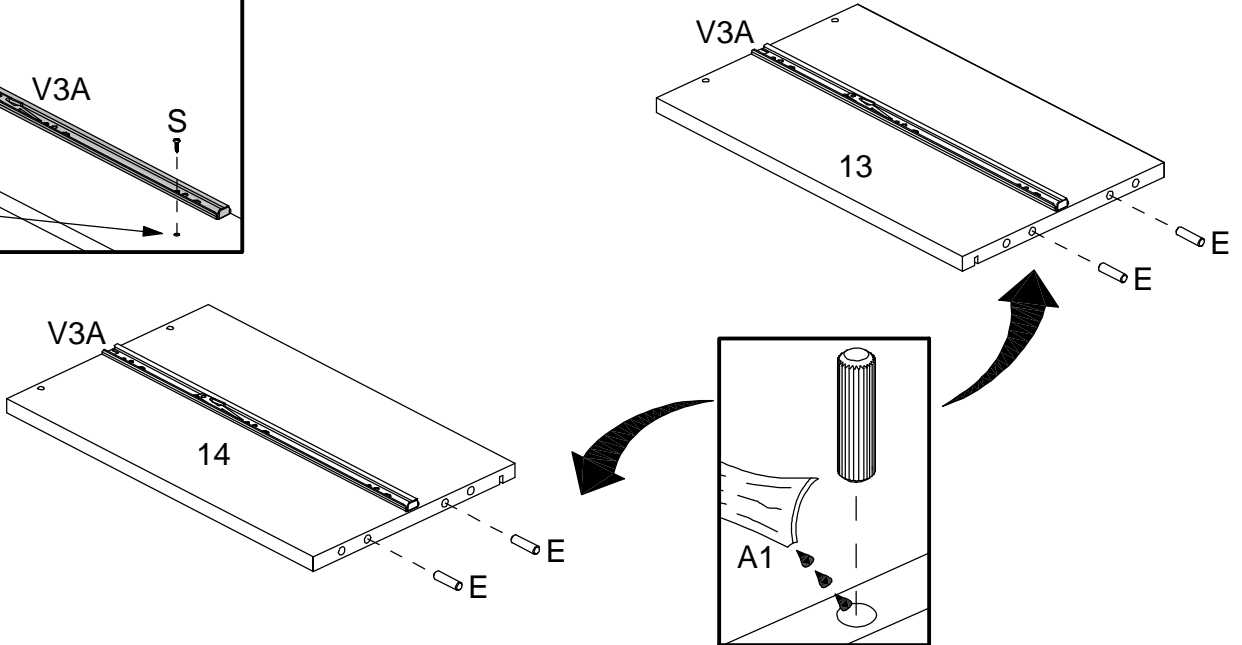
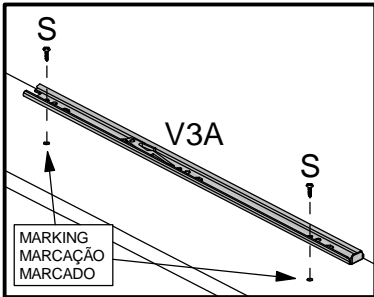

09

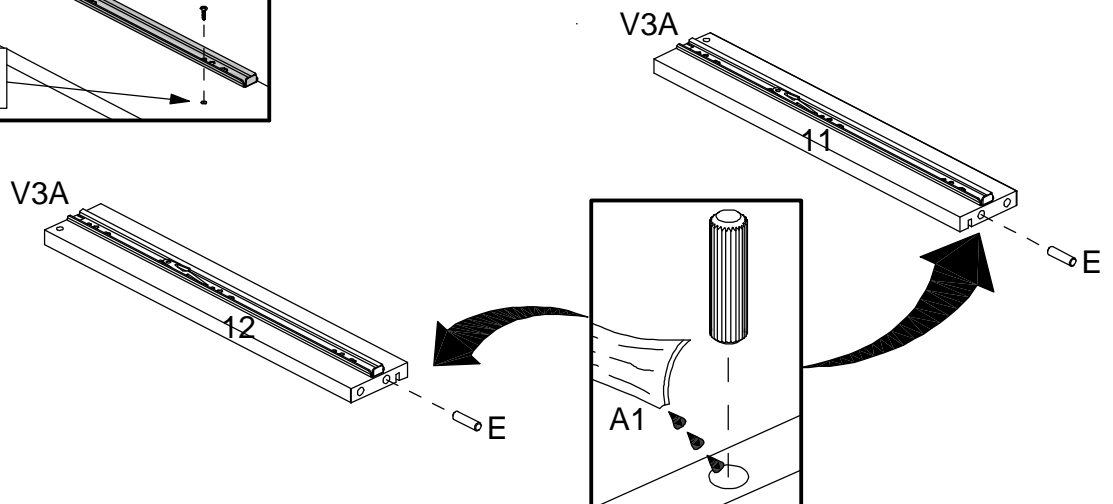
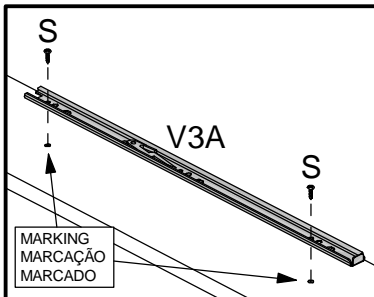

10

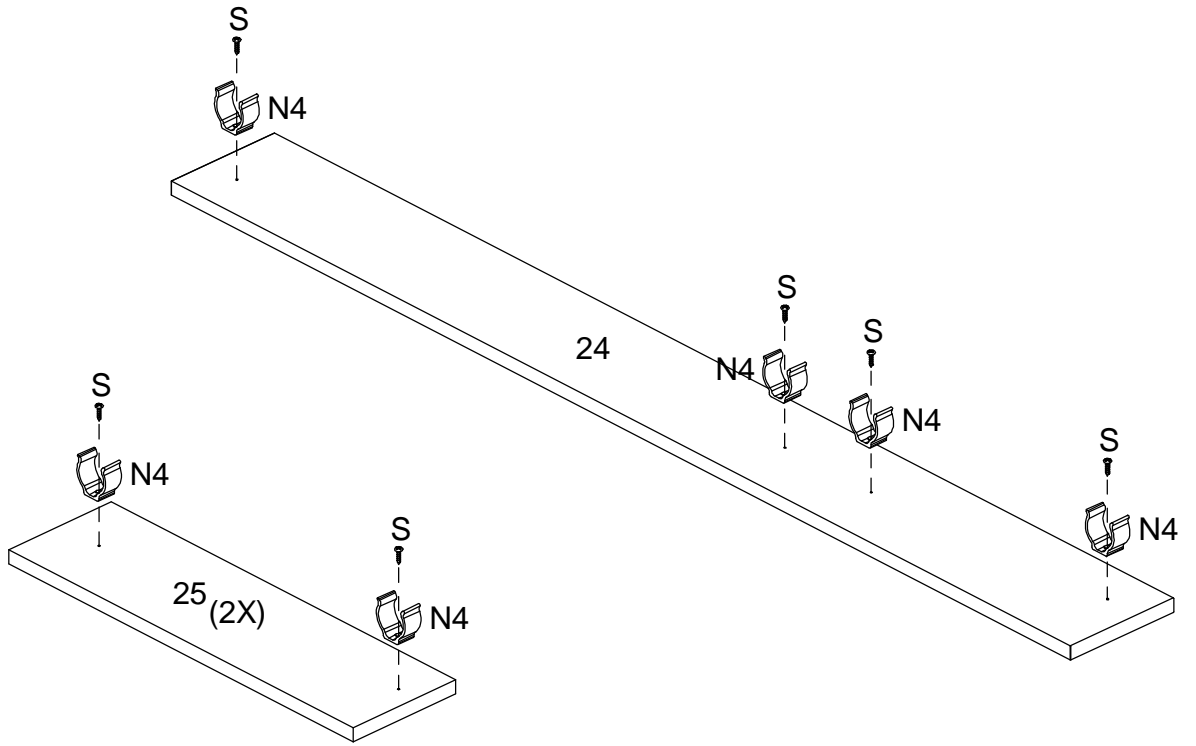

11

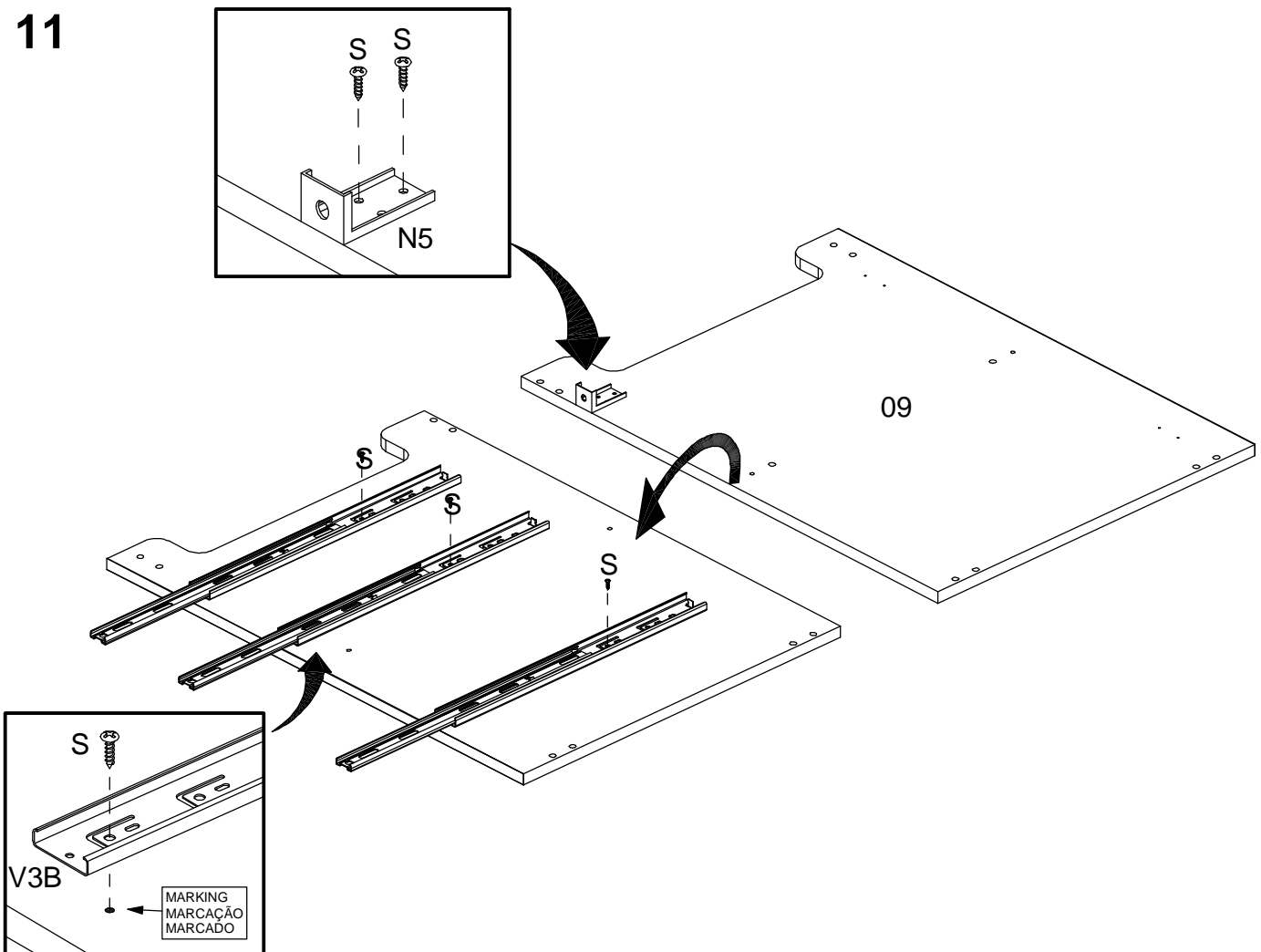

12

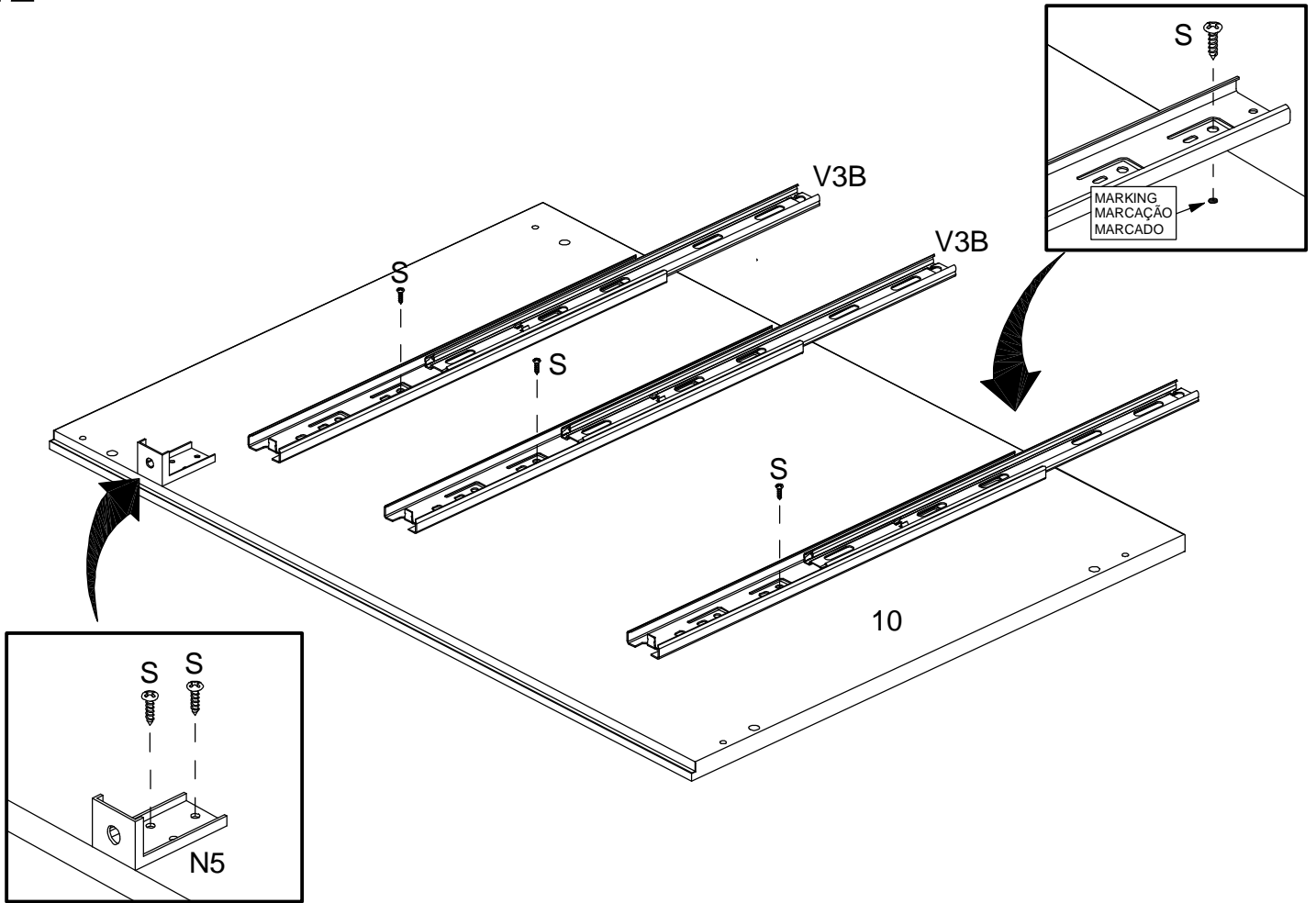

13

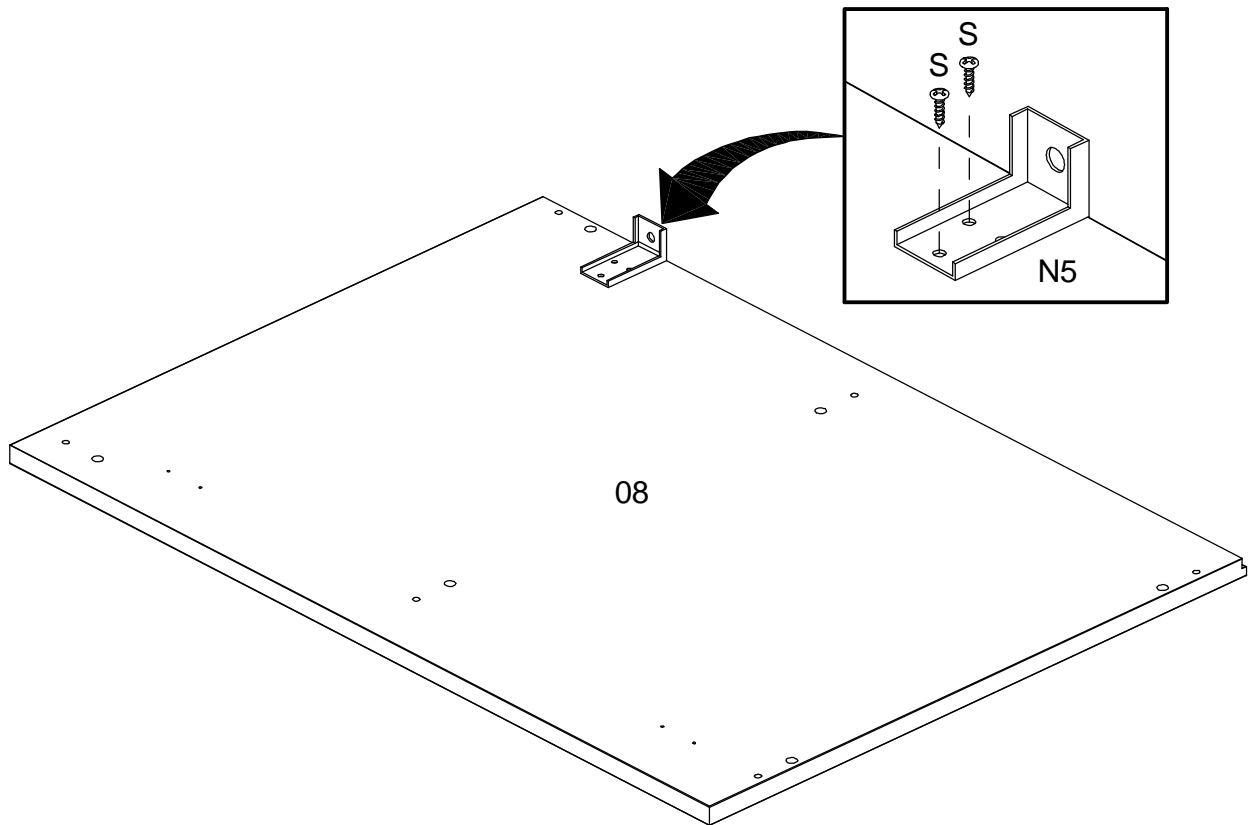

ASSEMBLY
MONTAGEM / ARMADO

14

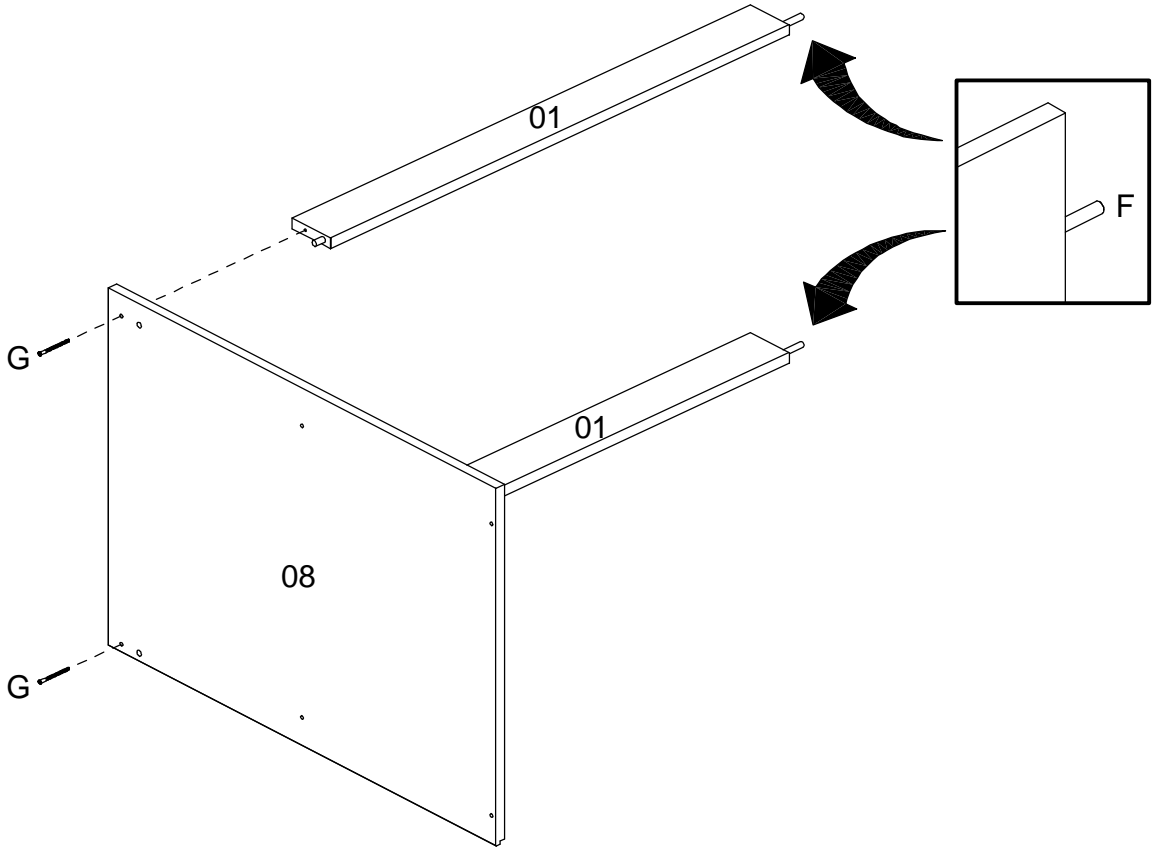
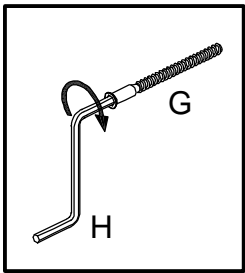

15

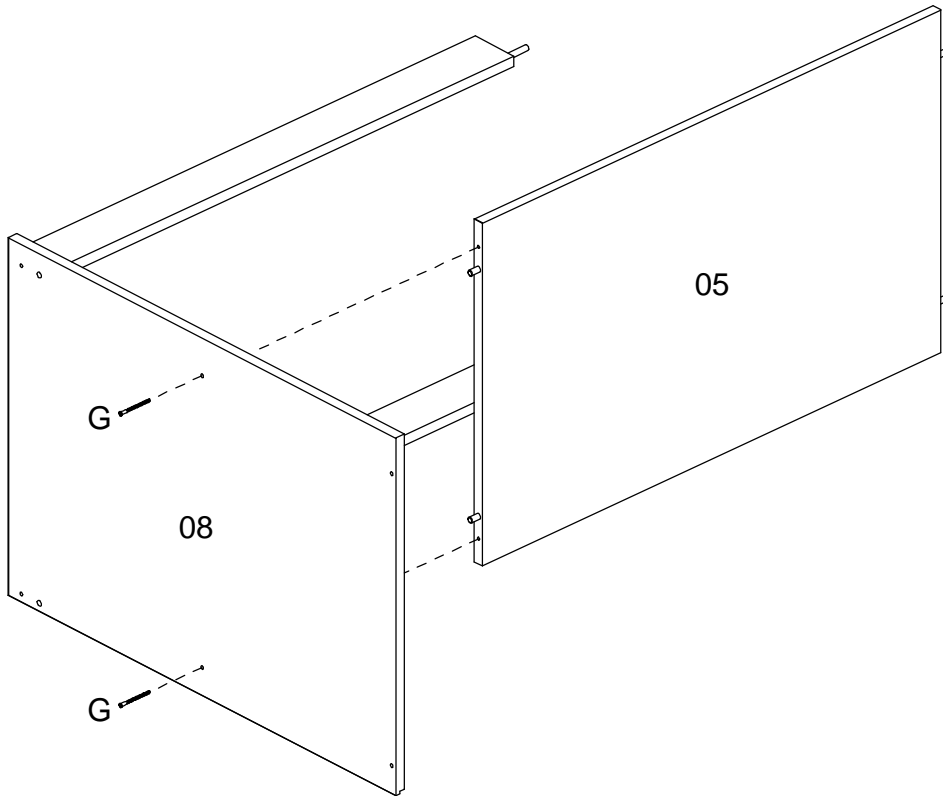

16

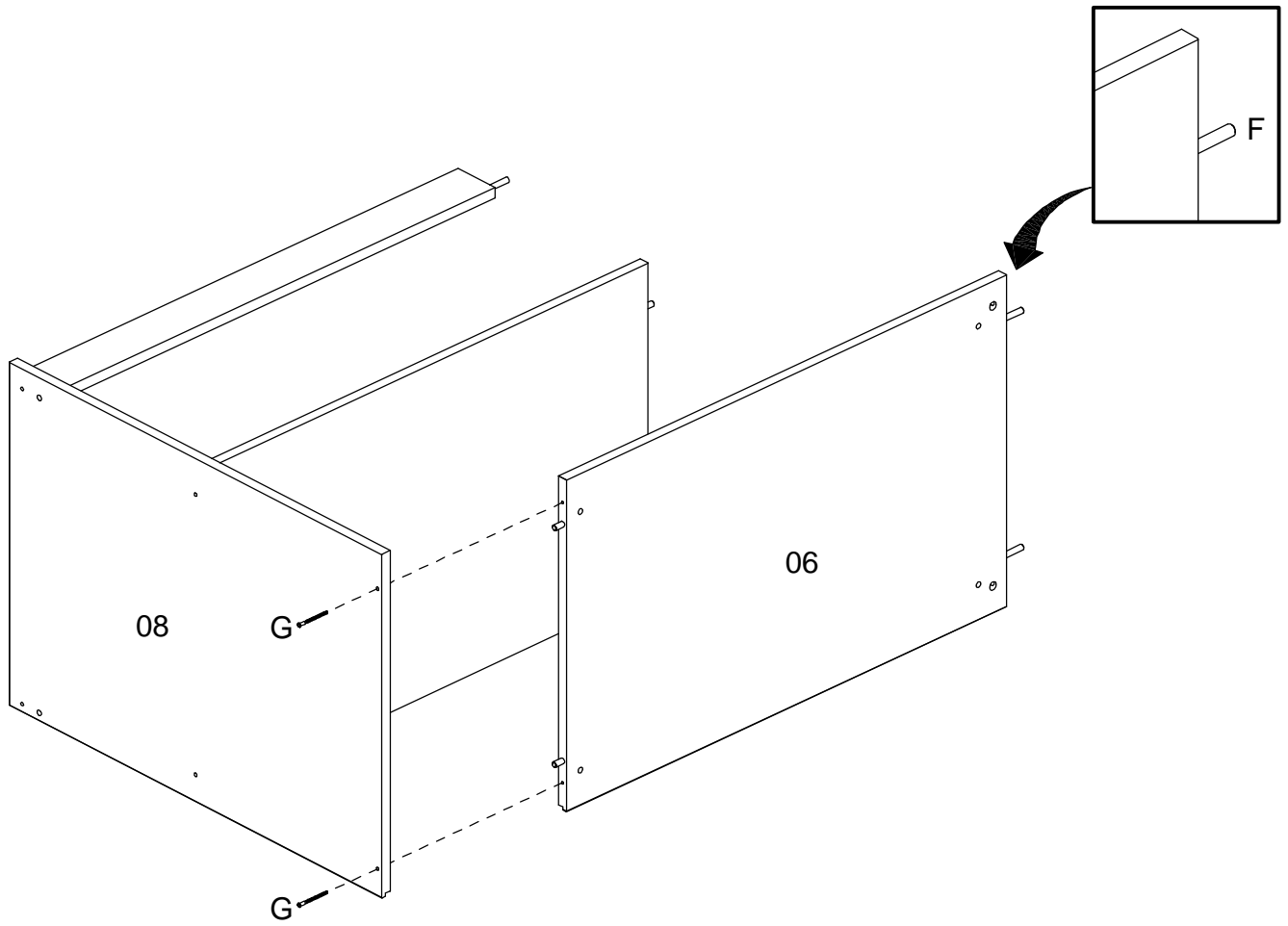

17

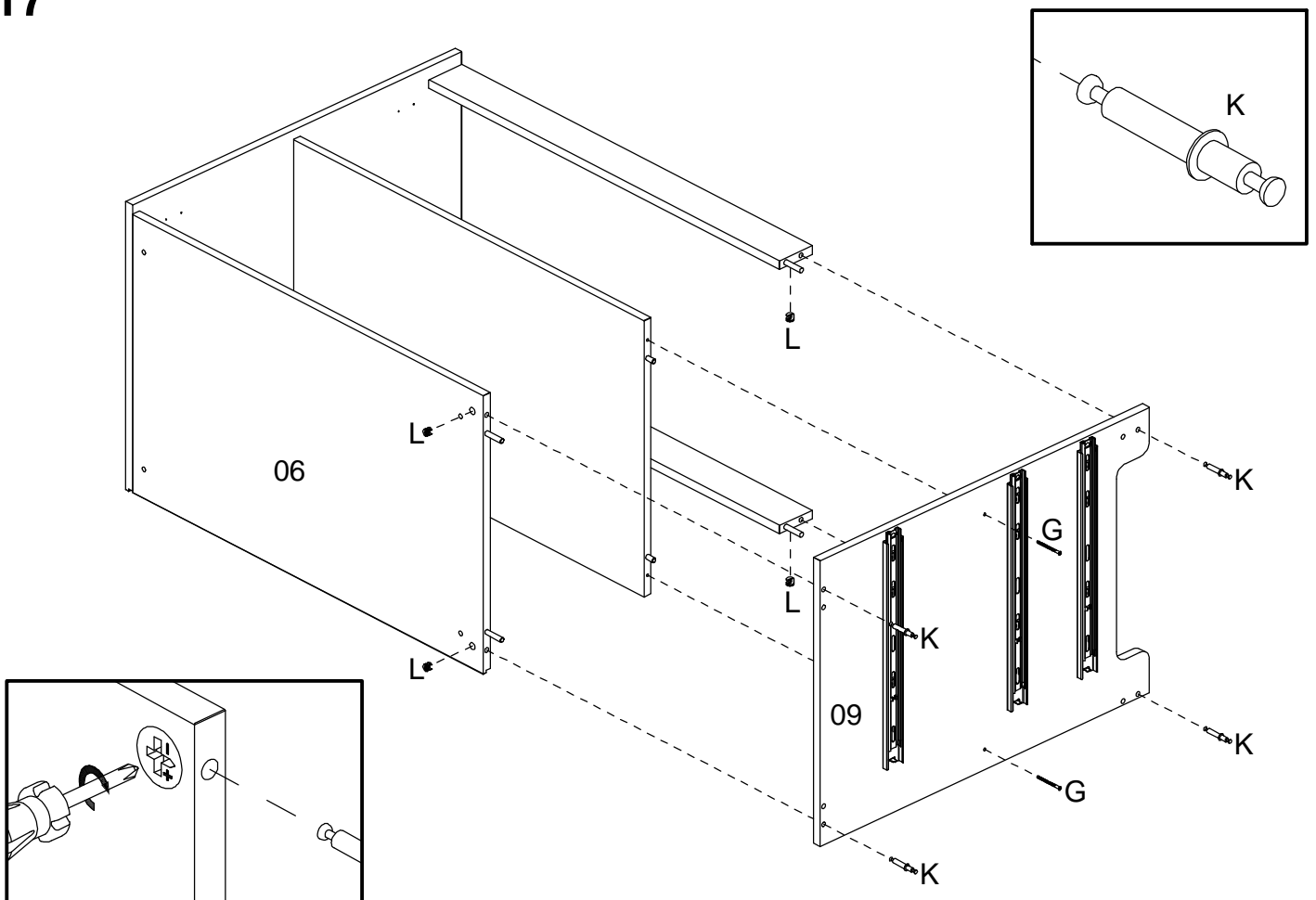

18

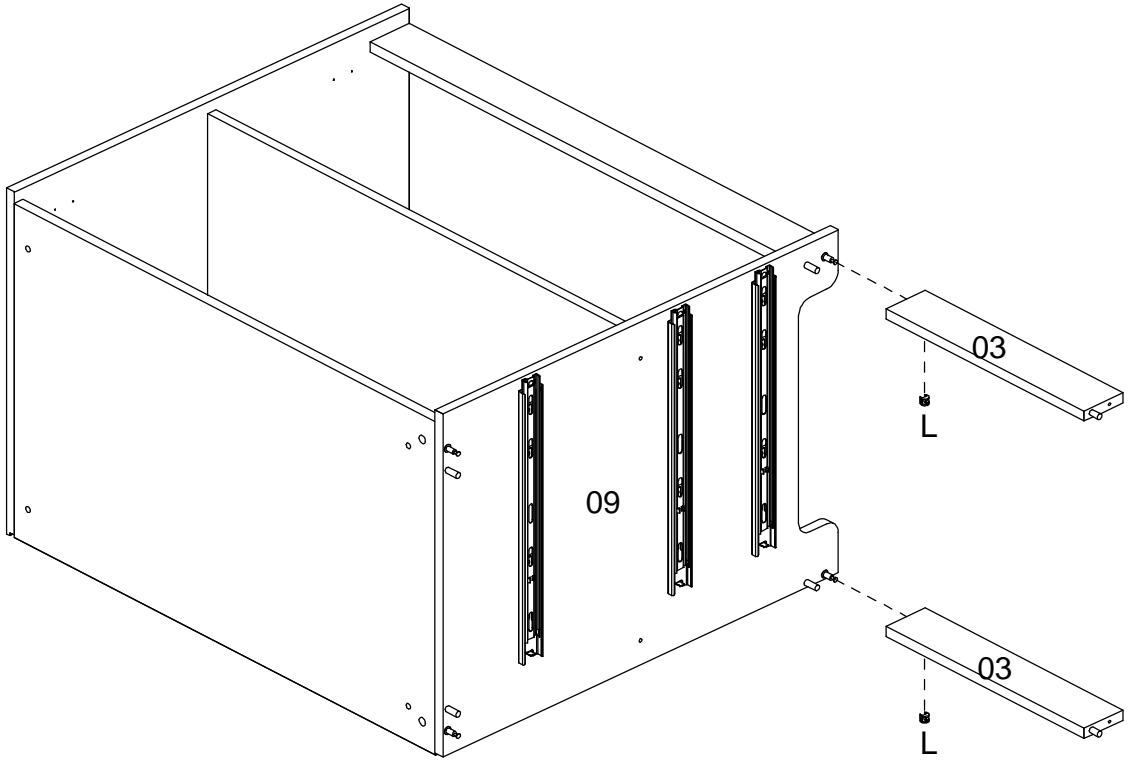

19

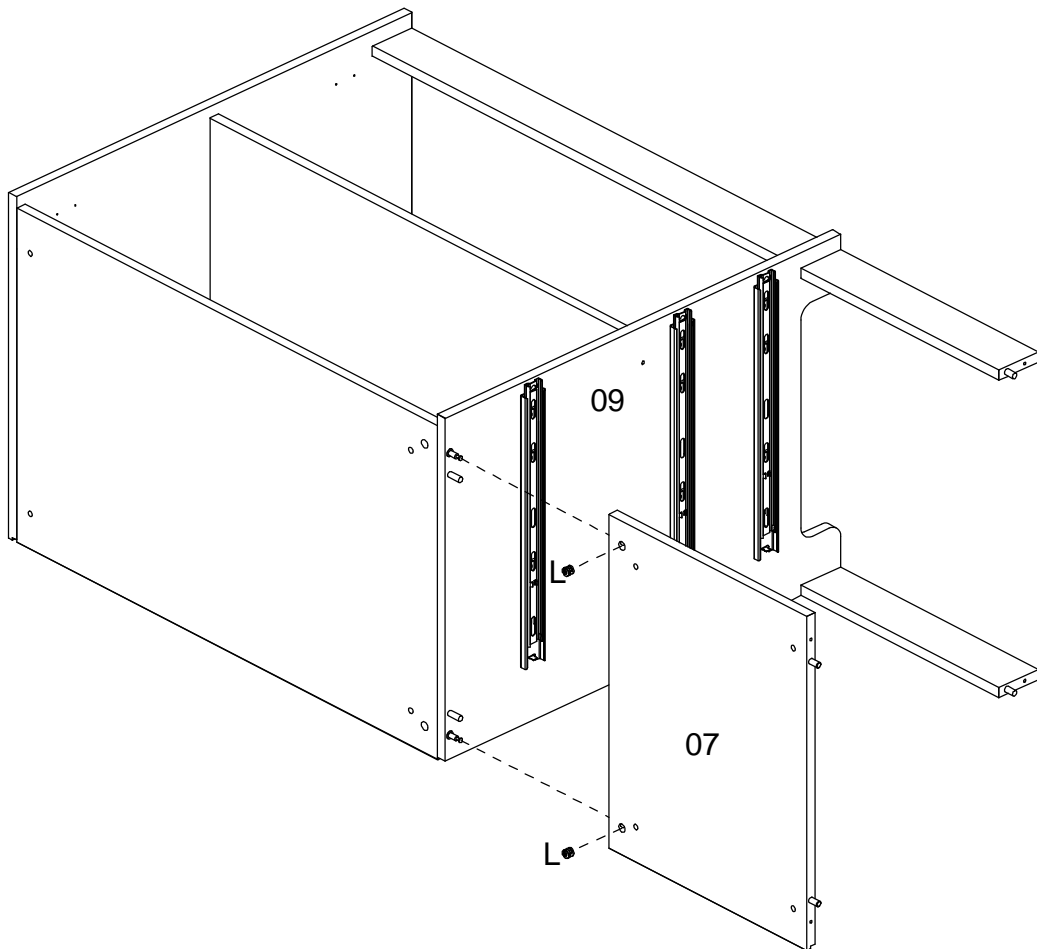

20

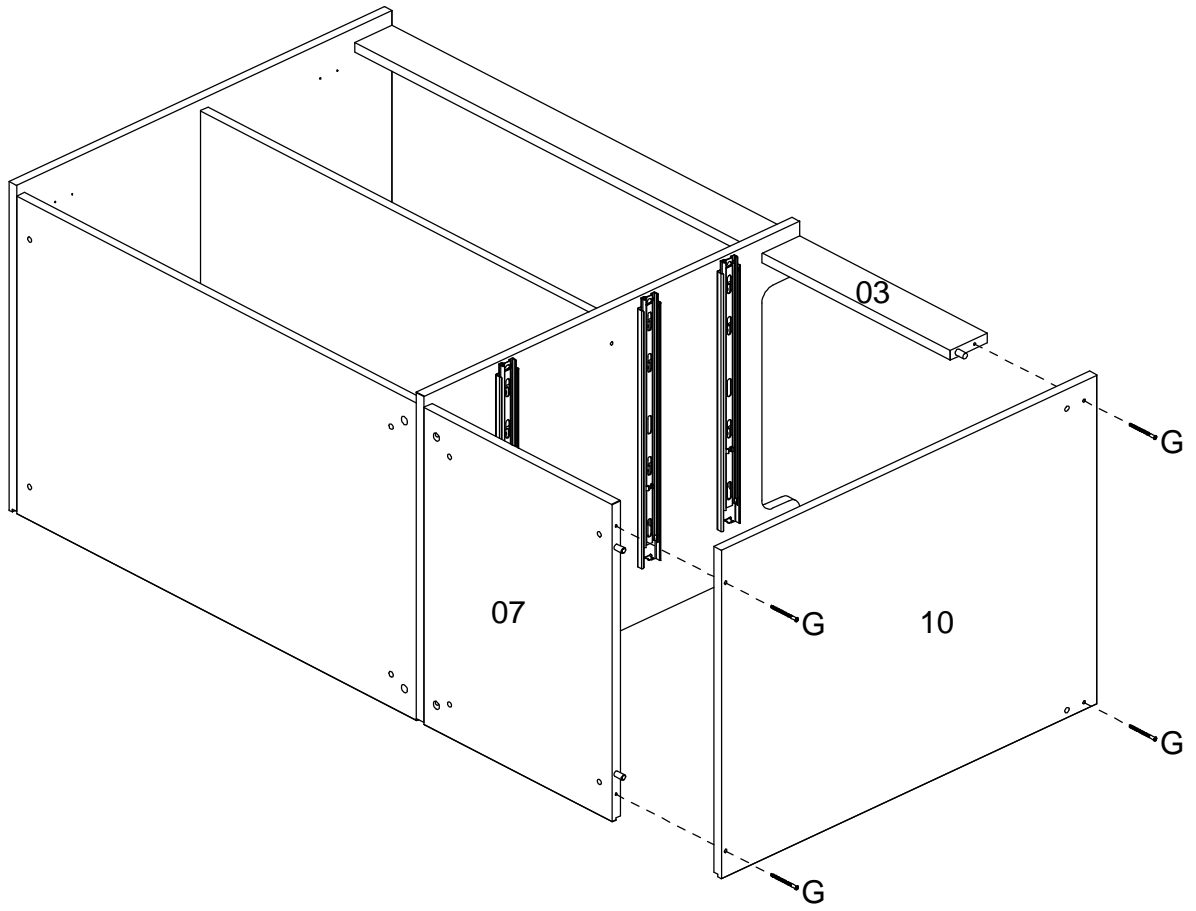

21

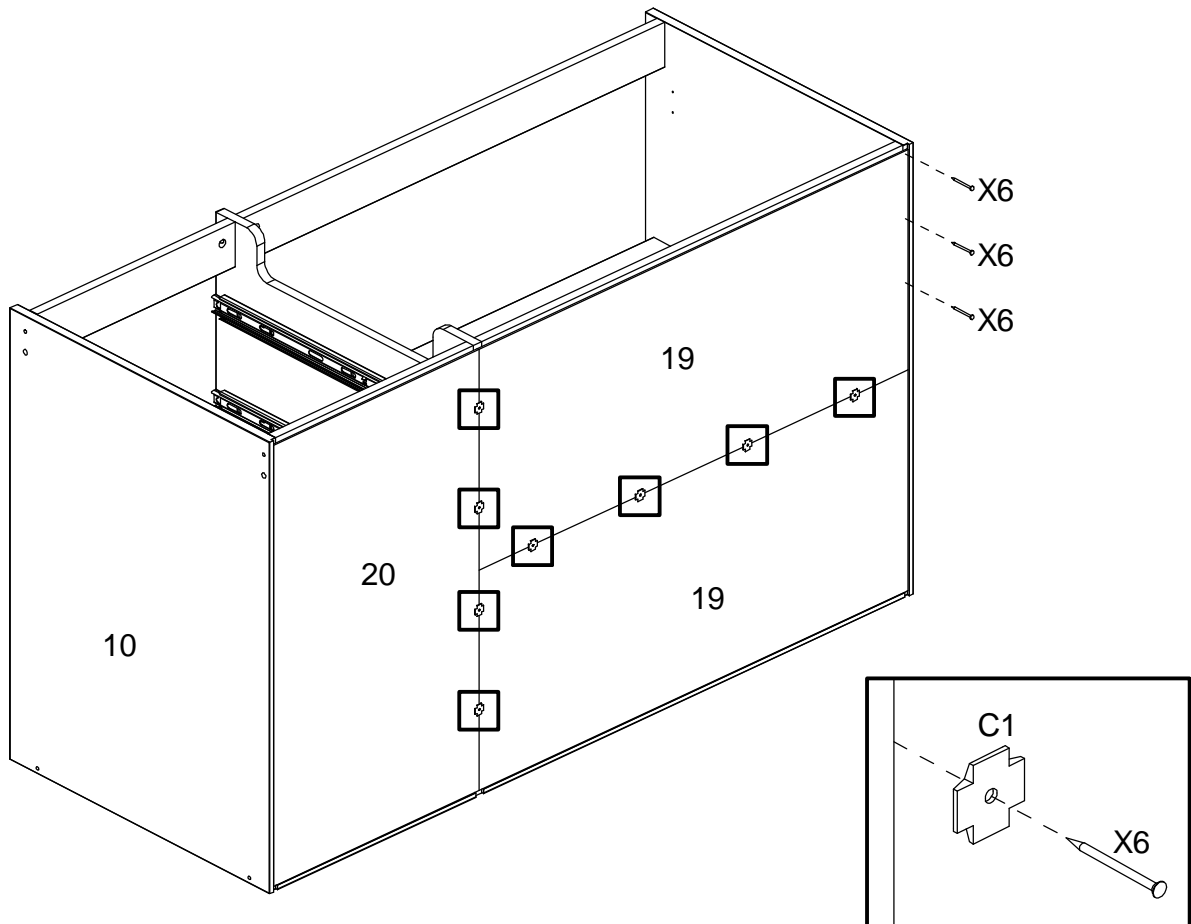

22

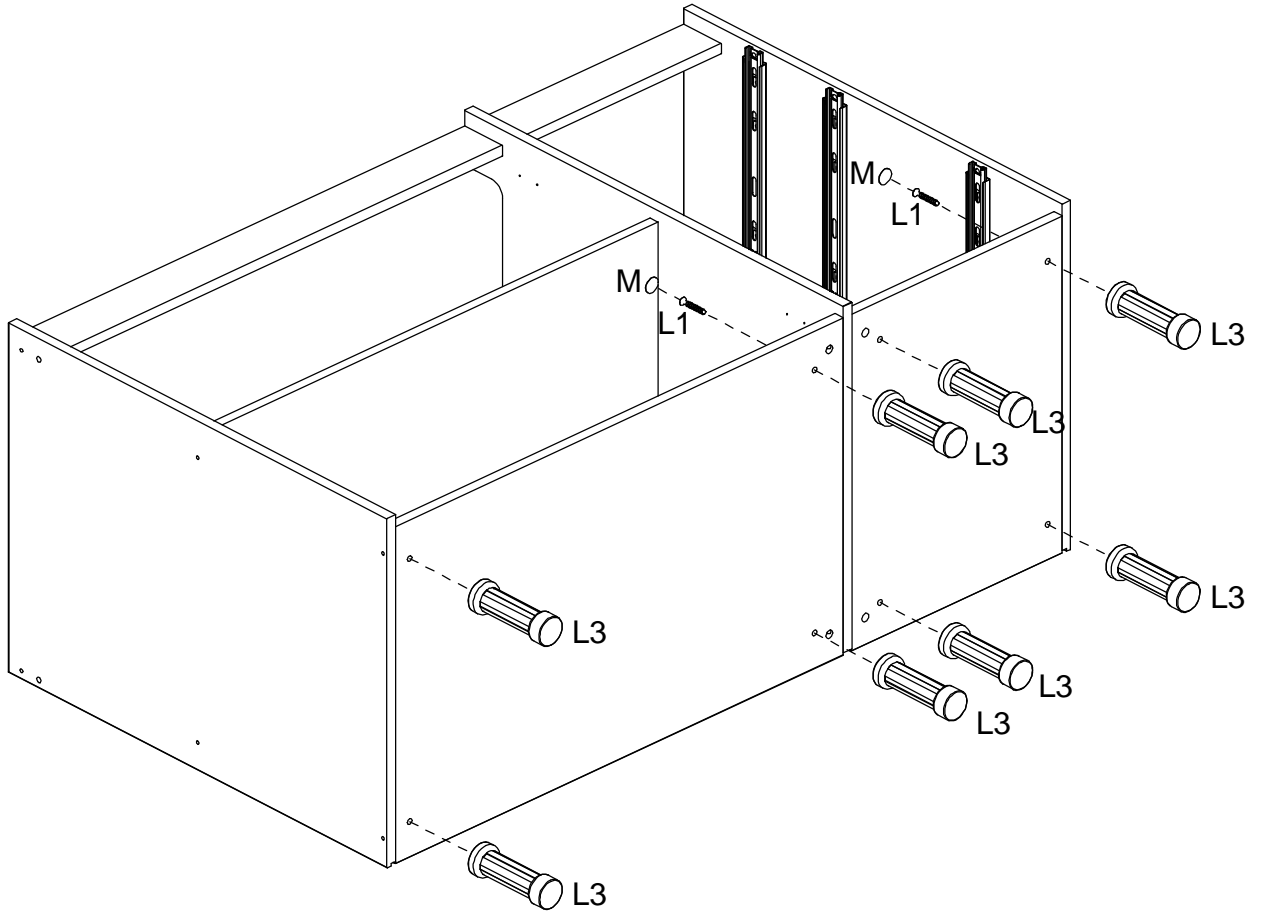

23

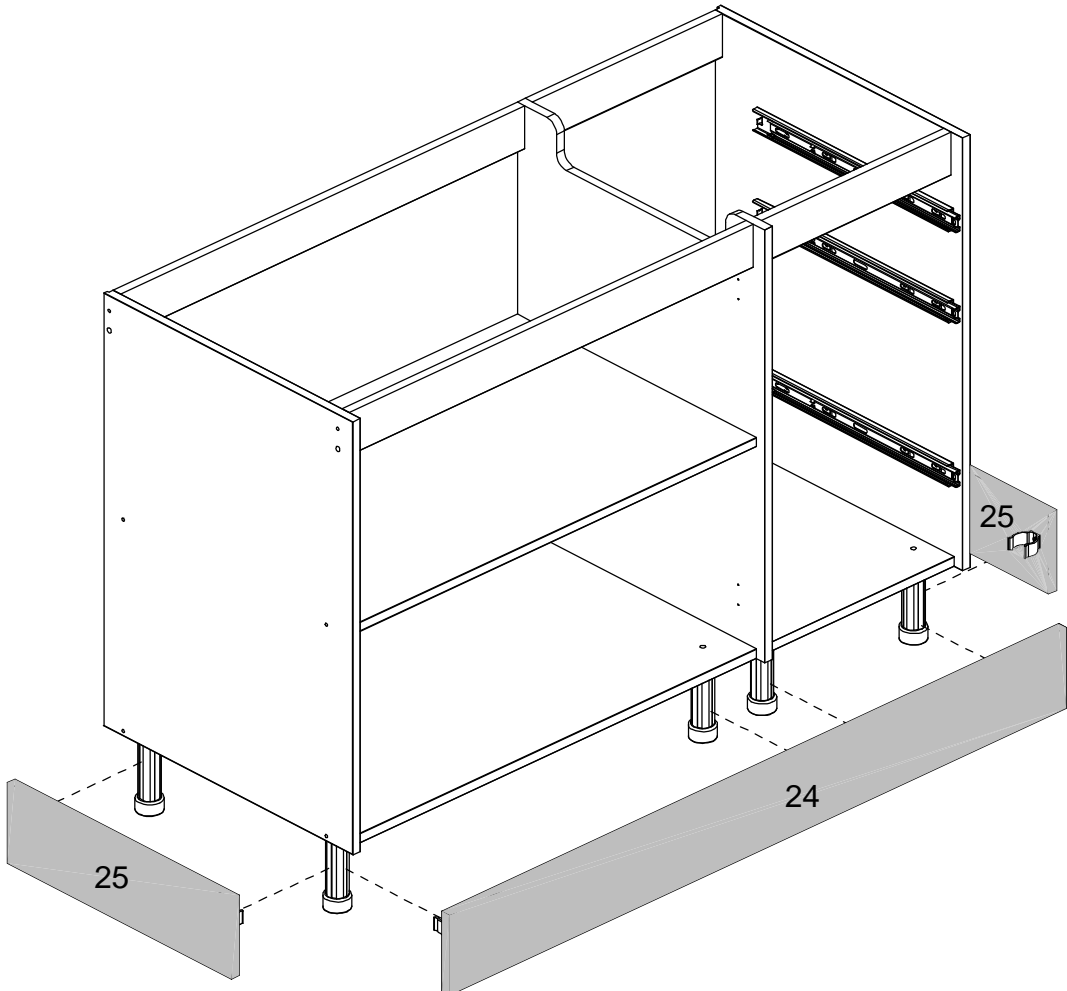

24

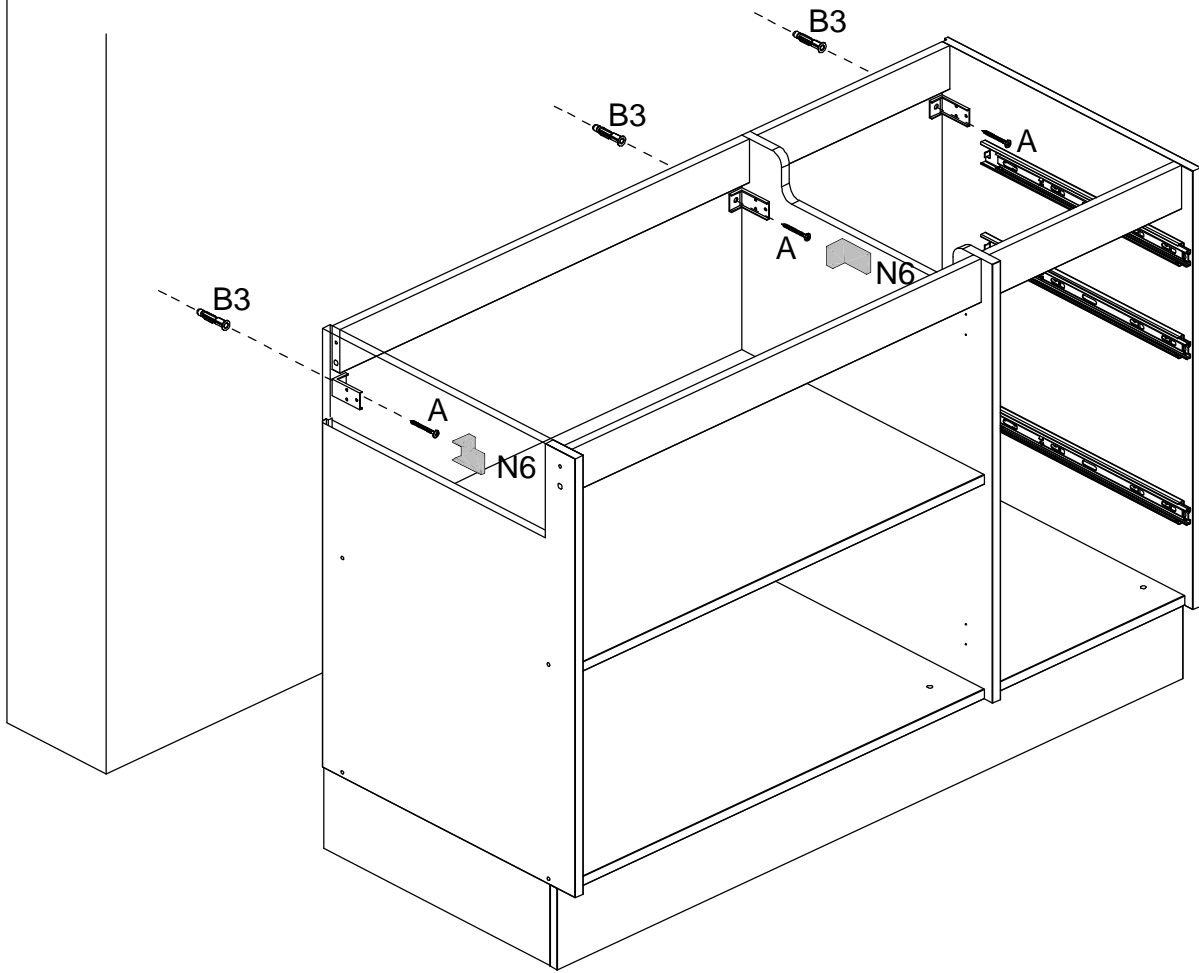

25

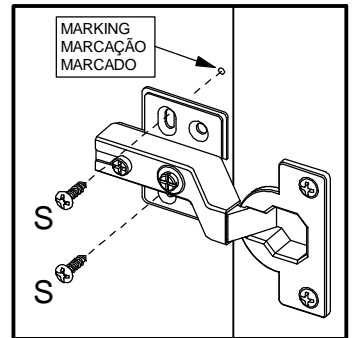
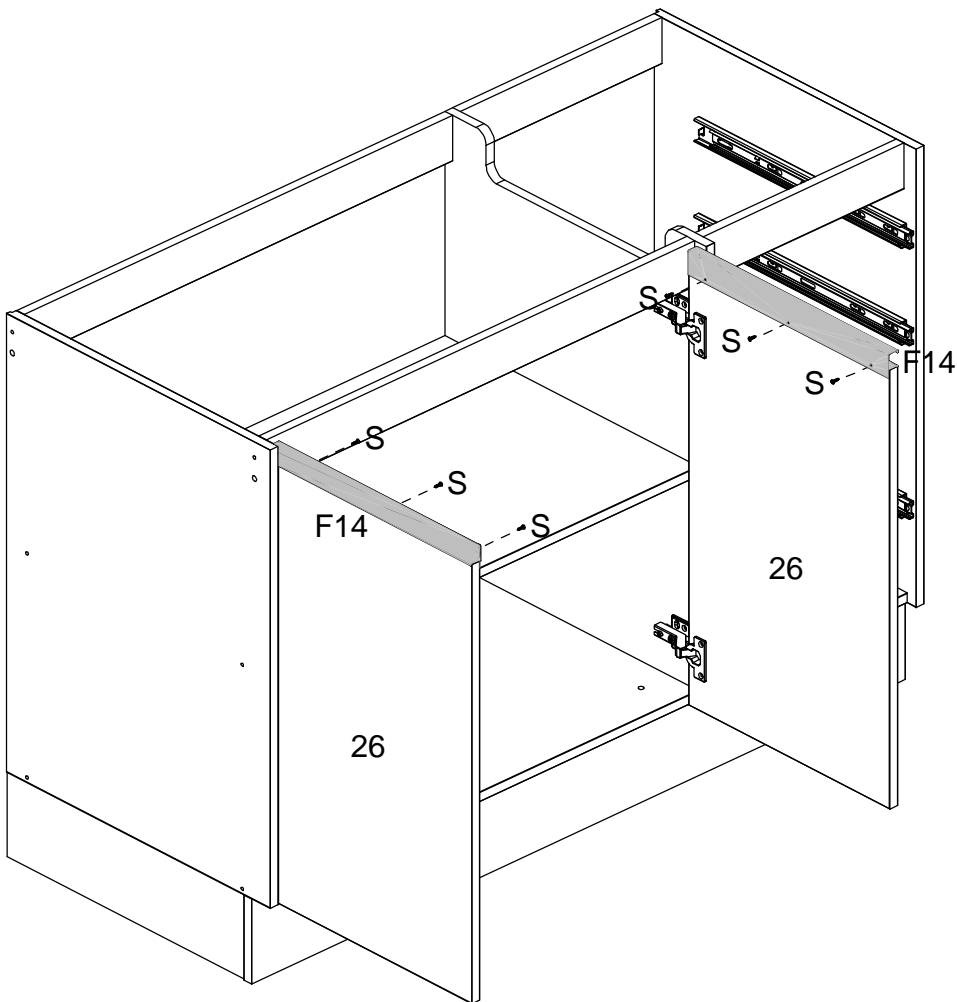

26

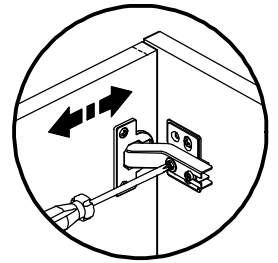
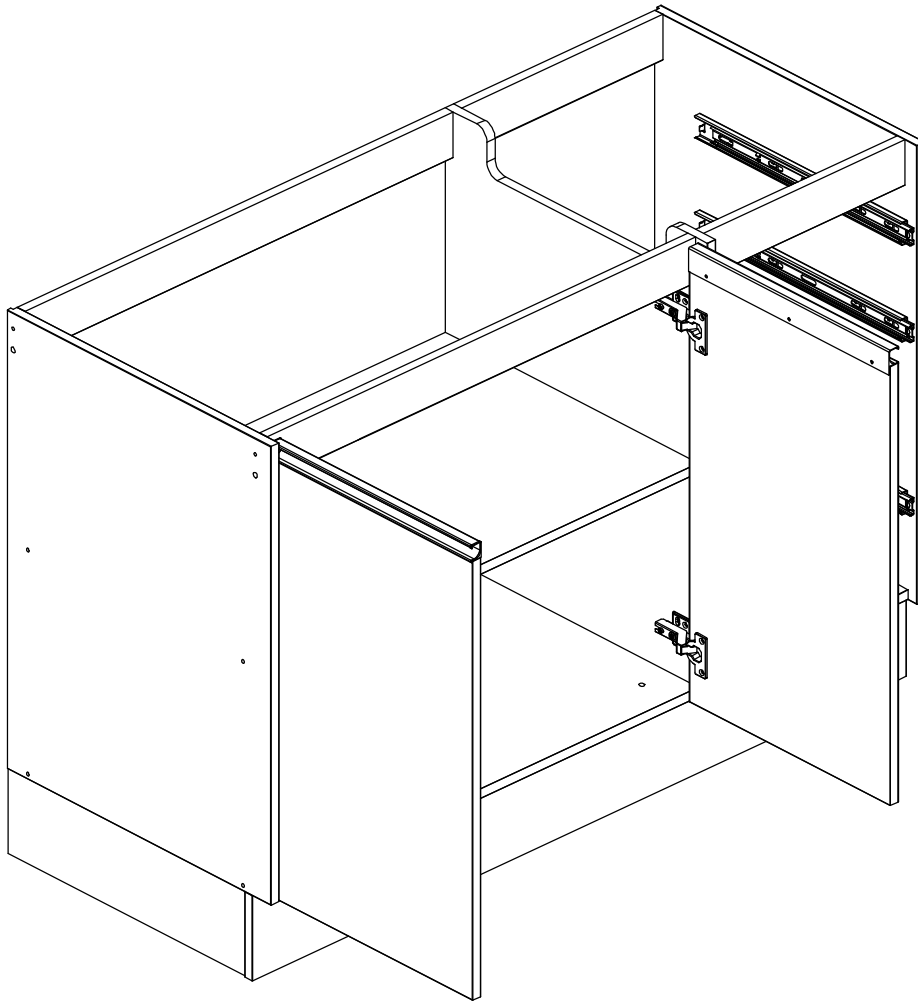

Horizontal Adjustment
Regulagem Horizontal
Ajuste Horizontal

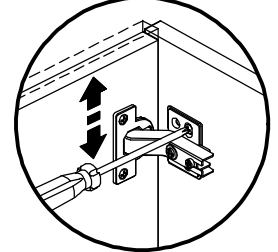

Vertical Adjustment
Regulagem Vertical
Ajuste Vertical

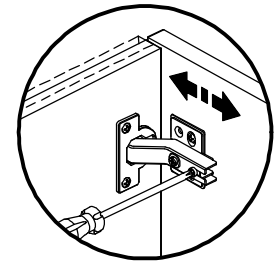

Depth Adjustment
Regulagem Profundidade
Ajuste Profundidade

27

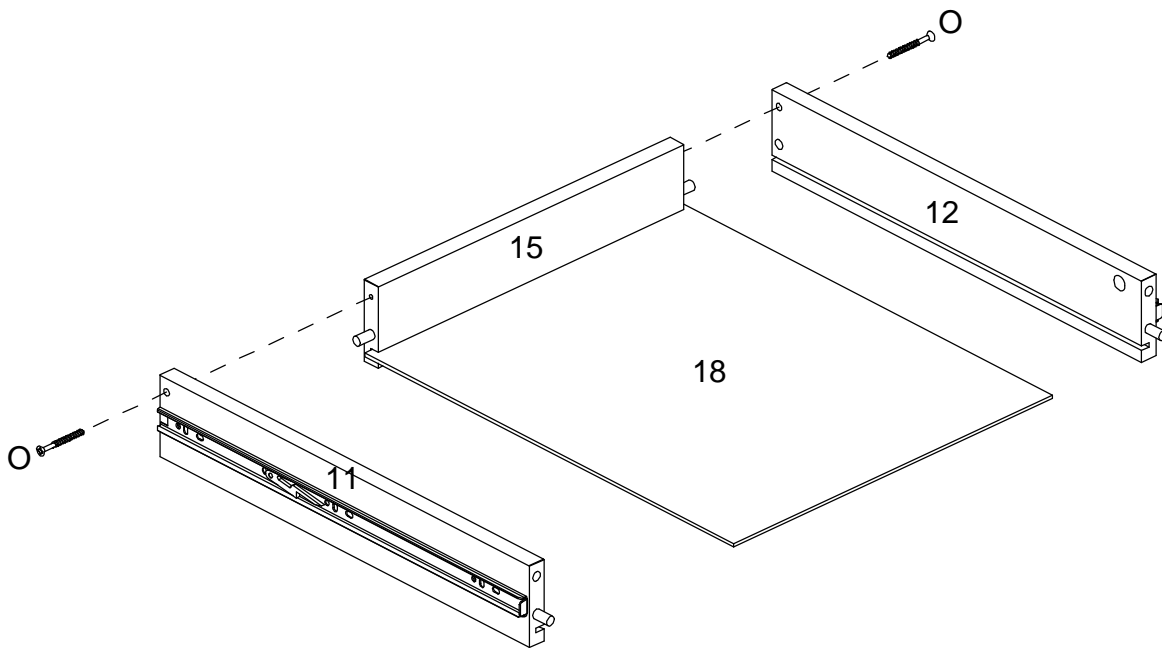

28

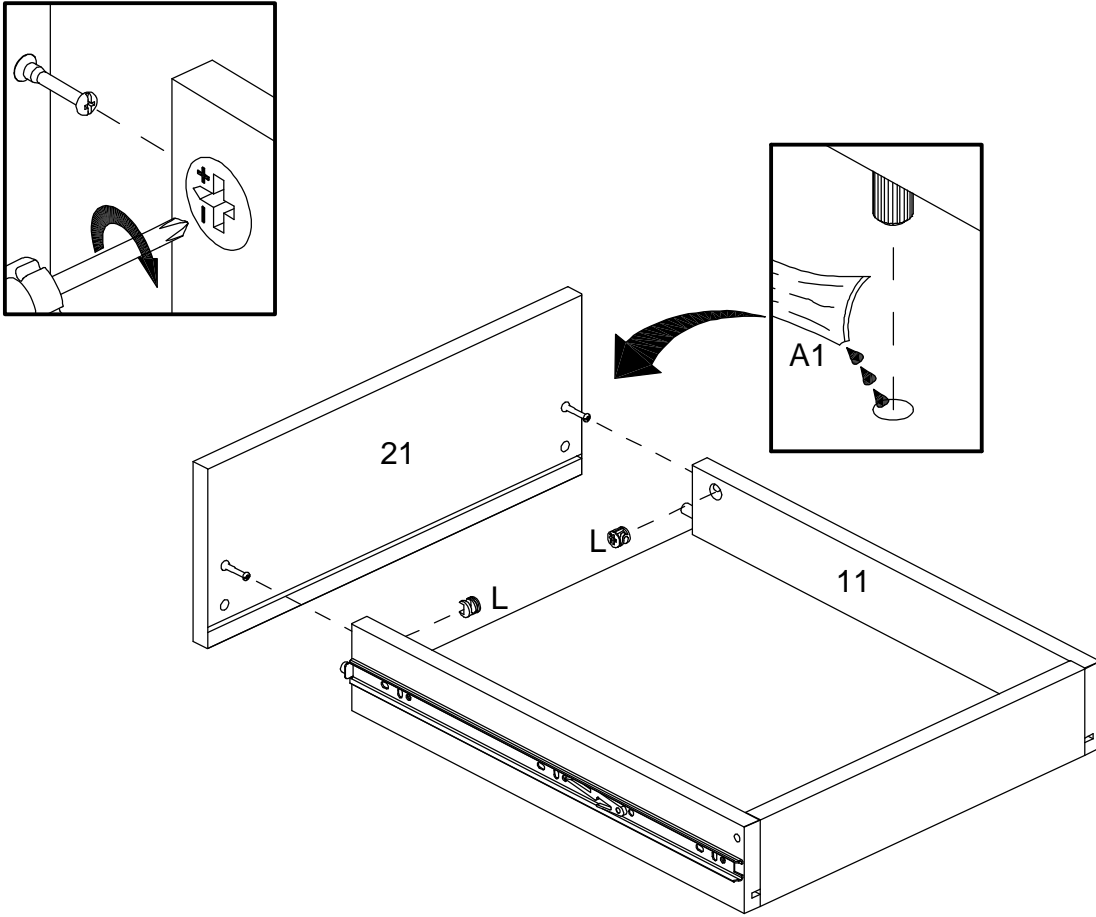

29

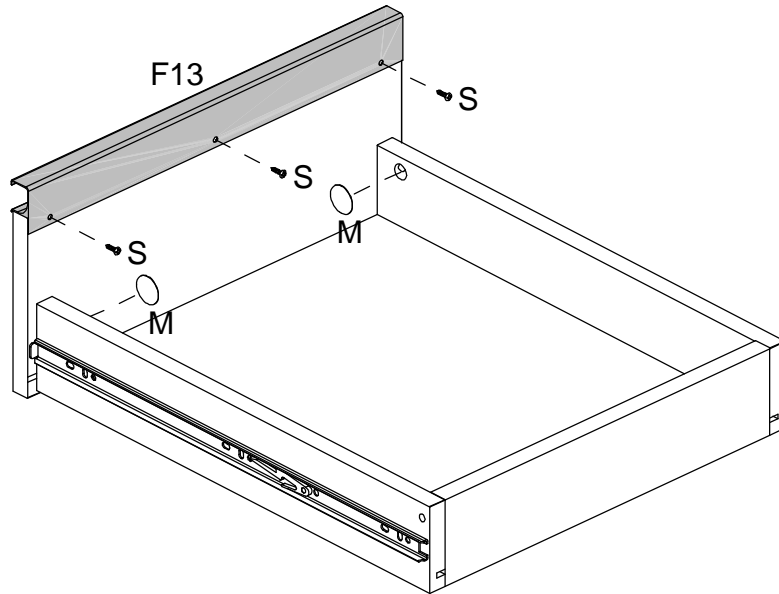

30

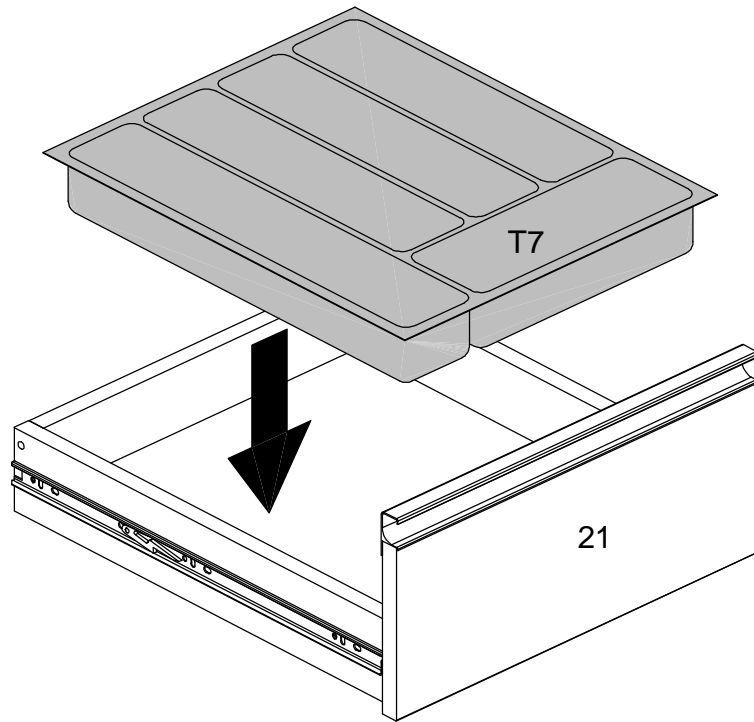

31

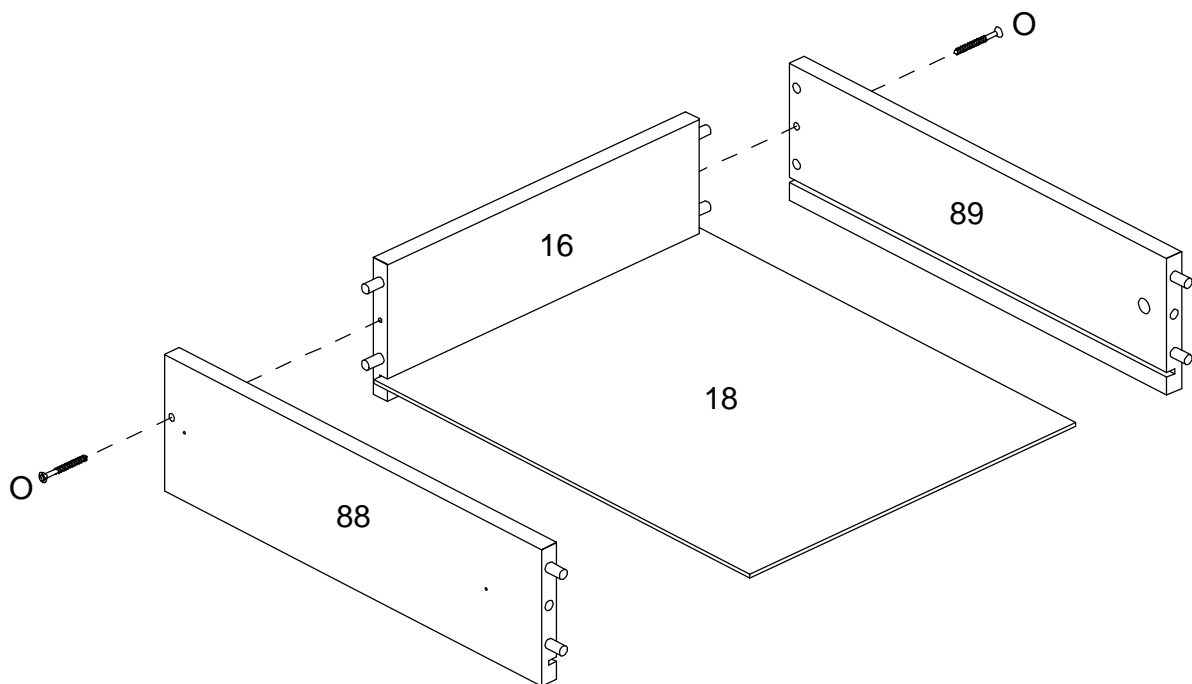

34

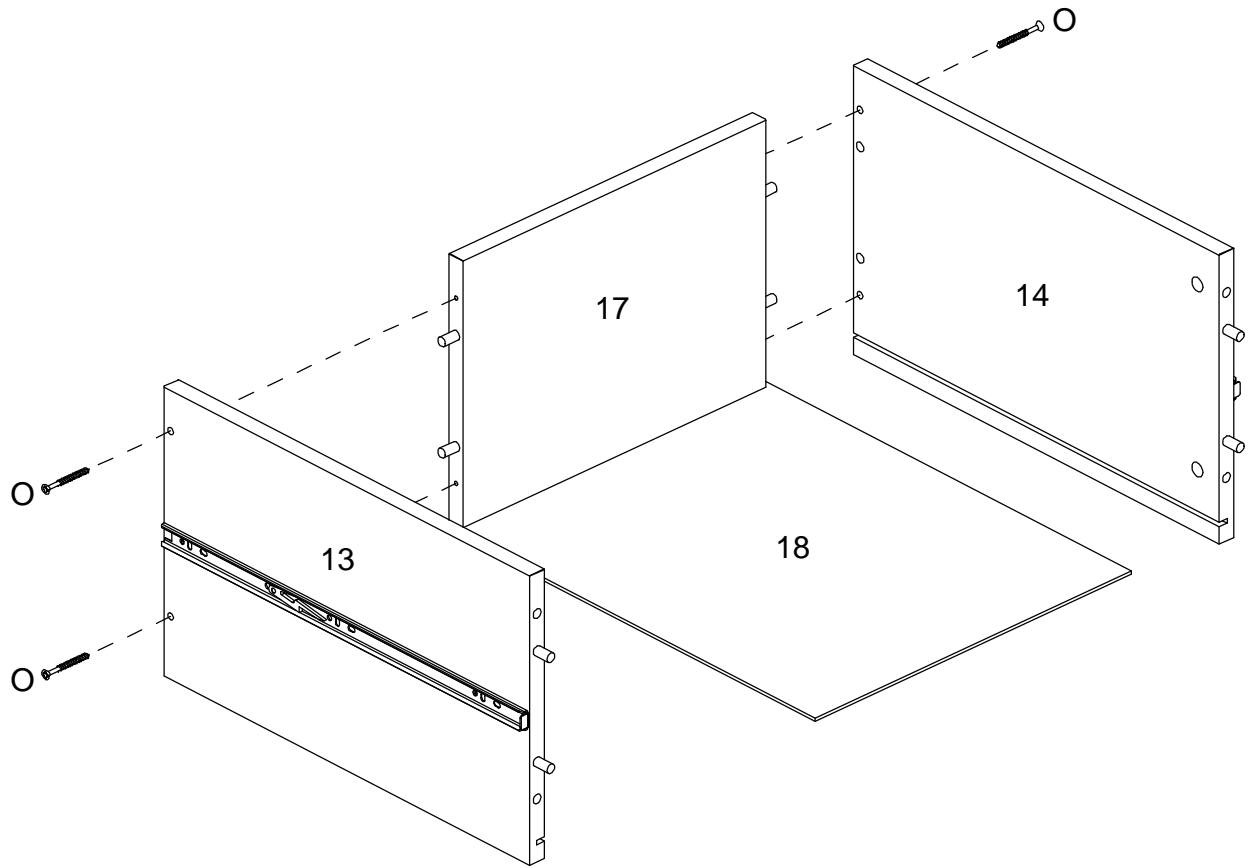

35

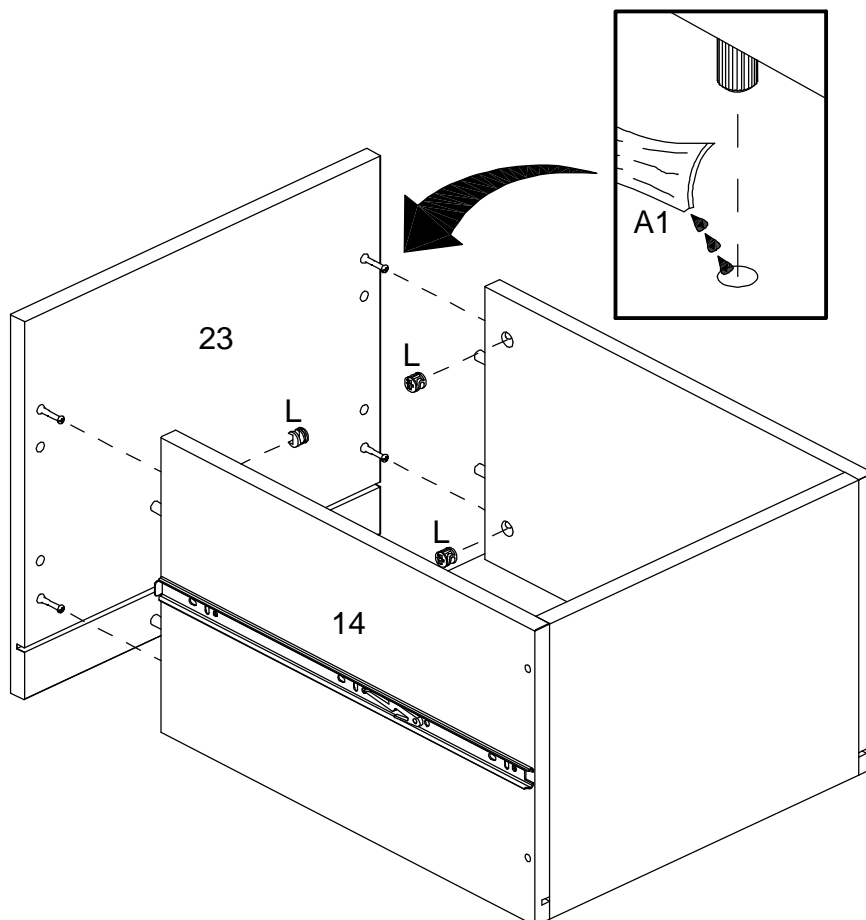

36

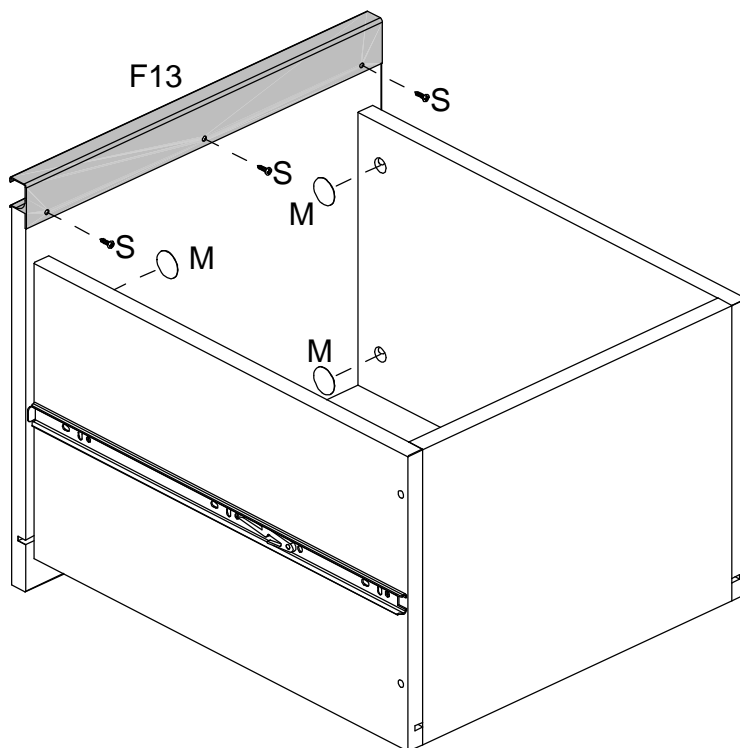

37

