

BALCAO 120

Instruções de Montagem Assembly Instructions Instrucciones de Montaje

Acesse Vídeos de Montagens
Access Mounting Videos
Acceder a los Vídeos de Montaje
www.tecnomobili.ind.br

tecnomobili

Estrada RSC 453, Km s/n° | Garibaldi | RS
CEP: 95720-000 | Fone / Fax: 54.3464.2050
sac@moveisvideira.com.br

Notas Especiais:

- 01** - Examine completamente todas as peças do móvel antes de começar o trabalho.
02 - Recomenda-se montar o móvel conforme este Manual de Montagem.
03 - É de responsabilidade do montador seguir as instruções do Manual de Montagem, que são fundamentais para garantir a estrutura do móvel.
04 - Para limpeza, utilizar somente pano úmido e sabão neutro.

Special notes:

- 01** - Check all parts of the unit thoroughly before starting work.
02 - It is recommended to assemble the furniture according to this Installation Manual.
03 - It is the responsibility of the assembler to follow the instructions in the Assembly Manual, which are essential to ensure the structure of the furniture.
04 - For cleaning use only damp cloth and neutral soap.

Notas especiales:

- 01** - Examine completamente todas las piezas del mueble antes de iniciar el trabajo.
02 - Se recomienda montar el mueble conforme el Manual de Ensamblaje.
03 - Es de responsabilidad del montador seguir las instrucciones del Manual de Ensamblaje, que son fundamentales para garantizar la estructura del mueble.
04 - Para limpieza solamente usar trapo húmedo y jabón neutro.

Guarante certificate:

The guarantee of products manufactured by Móveis Videira LTDA covers any defects / manufacturing defects, within the period established by the Consumer Protection Code, in its Article 26, II, which provides for a legal guarantee of ninety (90) days.



Lista de Peças / List of pieces / Lista de piezas

CÓD	DESCRIÇÃO	DESCRIPTION	DESCRIPCIÓN	QTD	RAW MATERIAL	DIMENSION	CÓD
01	Base	Base	Base	1	MDP 15mm	1198x490x15mm	121100
02	Lateral Esquerda	Left Side	Lateral Izquierda	1	MDP 15mm	665x490x15mm	311100
03	Lateral Direita	Right Side	Lateral Derecha	1	MDP 15mm	665x490x15mm	301100
04	Pilastra	Pilaster	Pilastra	1	MDP 15mm	649x65x15mm	601100
05	Divisão	Division	División	1	MDP 15mm	649x490x15mm	501100
06	Travessa Frontal	Front Rail	Traviesa Frontal	1	MDP 15mm	1168x45x15mm	621100
07	Travessa Traseira	Rear crossbar	Traviesa traseira	1	MDP 15mm	1168x60x15mm	611100
08	Costa	Back	Costa	2	MDP 03mm	1188x335x03mm	411100
09	Frete Gavetão	Front Hatch	Frete Gavett	1	MDP 15mm	396x333x15mm	61100
10	Lateral Gavetão	Side Drawer	Lateral Gavett	2	MDP 15mm	385x224x15mm	341101
11	Costa Gaveta Maior	larger drawer back	Fondo del cajón mas grande	1	MDP 15mm	345x224x15mm	431100
12	Frete Gaveta	drawer front	Frete de cajón	2	MDP 15mm	396x165x15mm	71100
13	Lateral Gaveta	drawer side	Lateral de cajón	4	MDP 15mm	385x85x15mm	321100
14	Fundo Gaveta	drawer Bottom	Fundo de cajón	3	MDP 03mm	394x323x03mm	421100
15	Costa Gaveta	drawer Back	Costa de cajón	2	MDP 15mm	345x85x15mm	401100
16	Prateleira Moveel	Mobile shelf	Estante Móvil	1	MDP 15mm	768x385x15mm	211100
17	Porta	Door	Puerta	2	MDP 15mm	670x396x15mm	81100
18	Pilastra Traseira	Rear Pilaster	Pilastra Traseira	1	MDP 15mm	569x65x15mm	631100

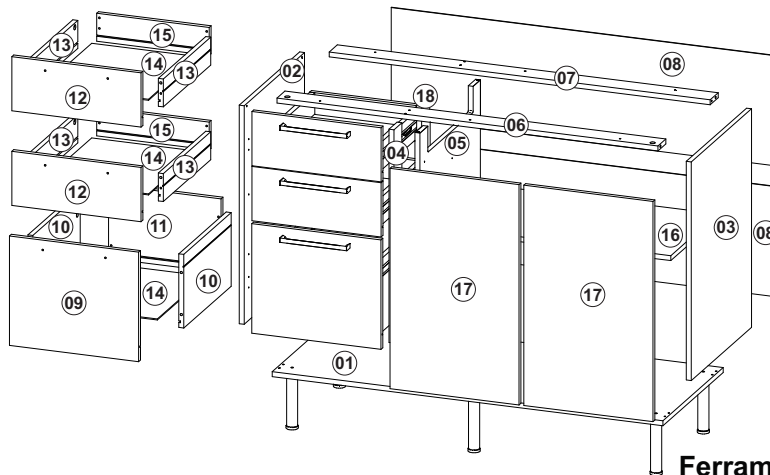

ATENÇÃO
Se necessário, utilizar parafuso B para junção de tampo

Ferramentas | Tools | Herramientas

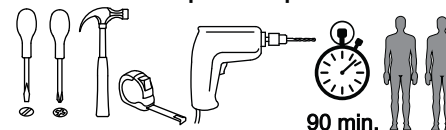

Revisão: 00
Data: 29/02/2024

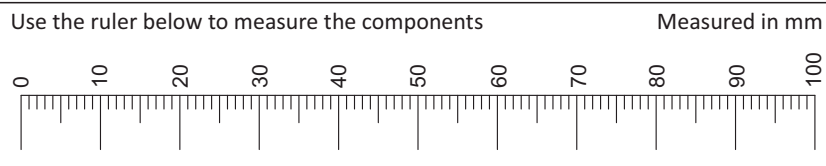

TAMANHO REAL - TAMANO VERDADERO - REAL SIZE

REF	DESCRIÇÃO	QTD	CÓD
A	3,5x14mm CC	54	3639
B	3,5x25mm CP	16	9623
C	Cavilha 5 x 30mm	18	3880
D	5,0x40mm CC	05	4000
E	5x45mm CF	02	2605

ILUSTRAÇÃO - ILUSTRACION - ILLUSTRATION

REF	DESCRIÇÃO	QTD	CÓD
F	22x3mm Prego 10x10	40	3051
G	Puxador Aleno FIT 192 entre furos	05	
H	34x7mm Parafuso minifix	20	3771
I	15x12mm Tambor minifix	20	9516
J	Dobradiça Reta C/Amortecedor Caneco 35mm	04	9934
K	40x8mm Bucha 8mm	02	5623
L	Corrediça Telescópica 350mm 350x30mm	03	1421
M	3,5x40mm CC	08	8115
N	Adesivo Tapa Furo	21	
O	Pé Plástico 170mm Com Detalhe Cromado	05	
P	43x43x25mm Cantoneira com Capa	02	5630
Q	14x8x5mm Suporte Prateleira 5x8 c/ estria	04	3748
R	3,5x25mm CC	06	0286

2

Opção lado esquerdo
Opcion lado izquierdo
Option left side

3

Opção lado esquerdo
Opcion lado izquierdo
Option left side

4

Opção lado esquerdo
Opcion lado izquierdo
Option left side

5

Opção lado esquerdo
Opcion lado izquierdo
Option left side

6

x4

x2

x2 (M)

x2

Opção lado esquerdo
 Opcion lado izquierdo
 Option left side

7

x40 (F)

Opção lado esquerdo
 Opcion lado izquierdo
 Option left side

8

x2 (B)

x1 (L, A)

x8 (M)

9

x4 (B)

x2 (L, A)

x4 (M)

Repeat
 x2

10

1º
 Broca não inclusa
 Drill not included
 Broca ø 8mm
 Drill ø 8mm

PAREDE
 WALL
 PARED

3º **E** x2

2º **K** x2

PAREDE
 WALL
 PARED

4º **P** x2

⚠ CUIDADO!

-AS FERRAGENS DESTE PRODUTO NÃO PODEM SER UTILIZADAS EM PAREDES DRYWALL
 -UTILIZAR A BUCHA APENAS EM PAREDES DE ALVENARIA

11

Retirar Gaveta
 Sacar Cajón
 Remove Drawer

Q x4

12

Ajuste das Portas- Ajustes de las Puertas- Doors Adjustment

1º

AFLOJAR O PARAFUSO DO CALÇO EM SENTIDO ANTI-HORÁRIO

2º

AFERTAR O PARAFUSO DO CALÇO EM SENTIDO HORÁRIO

3º

R

Se necessário
 Utilizar o parafuso R
 Para unir os módulos

N x21

G

B x2

13

Opção lado Direito
Opcion lado Derecho
Option righth side

14

Opção lado Direito
Opcion lado Derecho
Option righth side

15

Opção lado Direito
Opcion lado Derecho
Option righth side

16

Opção lado Direito
Opcion lado Derecho
Option righth side

17

Opção lado Direito
 Opcion lado Derecho
 Option righth side

x40 **F**

18

1º PAREDE WALL PARED
 Broca não Incluída
 Drill not included
 Broca e 6mm
 Drill e 6mm

3º **E** x2

2º **K** x2

4º **P** x2

CUIDADO!
 AS FERRAGENS DESTES PRODUTO
 NÃO PODEM SER UTILIZADAS EM
 PAREDES DRYWALL
 -UTILIZAR A BUCHA APENAS EM
 PAREDES DE ALVENARIA

Opção lado Direito
 Opcion lado Derecho
 Option righth side

19

Retirar Gaveta
 Sacar Cajón
 Remove Drawer

Q x4

16

3Kg
 3Kg
 5Kg

20 Ajuste das Portas-Ajustes de las Puertas- Doors Ajustment

1º

2º

3º

N x21

B x2

K

Se necessário
 Utilizar o parafuso K
 Para centrar os módulos

17

7Kg
 10Kg

TAMPO 120

Instruções de Montagem Assembly Instructions Instrucciones de Armado

Acesse Vídeos de Montagens
Access Mounting Videos
Acceder a los Vídeos de Montaje
www.tecnomobili.ind.br

tecnomobili

Estrada RSC 453, Km s/n° | Garibaldi | RS
CEP: 95720-000 | Fone / Fax: 54.3464.2050
sac@moveisvideira.com.br

Notas Especiais:

01 -Examine completamente todas as peças do móvel antes de começar o trabalho.

02 -Recomenda-se montar o móvel conforme este Manual de Montagem.

03 -É de responsabilidade do montador seguir as instruções do Manual de Montagem, que são fundamentais para garantir a estrutura do móvel.

04 -Para limpeza, utilizar somente pano úmido e sabão neutro.

Special notes:

01 -Check all parts of the unit thoroughly before starting work.

02 -It is recommended to assemble the furniture according to this Installation Manual.

to follow the instructions in the Assembly Manual, which are essential to ensure the structure of the furniture.

04 -For cleaning use only damp cloth and neutral soap.

Notas especiales:

01 -Examine completamente todas las piezas del mueble antes de iniciar el trabajo.

02 -Se recomienda montar el mueble conforme el Manual de Ensamblaje.

03 -Es de responsabilidad del montador seguir las instrucciones del Manual de Ensamblaje, que son fundamentales para garantizar la estructura del mueble.

04 - Para limpieza solamente usar trapo húmedo y jabón neutro.

Guarante certificate:

Móveis Videira LTDA covers any defects / manufacturing defects, within the period established by the Consumer Protection

legal guarantee of ninety (90) days.



Lista de Peças / List of pieces / Lista de piezas

Cód	DESCRIÇÃO	DESCRIPTION	DESCRIPCION	QTD	RAW MATERIAL	DIMENSION	CÓD
01	Tampo	Top	Tapa	1	MDP 25mm	1199x520x25mm	701113
02	Espelho	Mirror	Espejo	1	MDP 25mm	1199x92x25mm	601117

TAMANHO REAL - TAMAÑO VERDADERO - REAL SIZE

REF	DESCRIÇÃO	QTD	CÓD
A	 Parafuso 4,0 x 45mm CF	05	9510

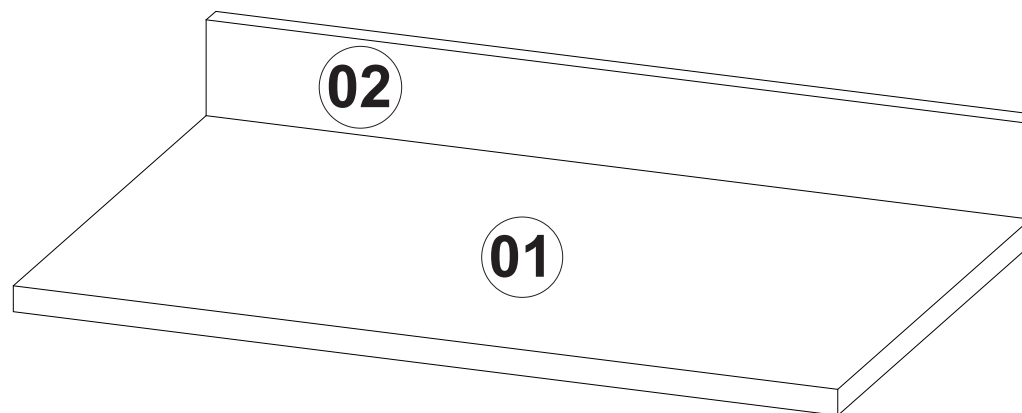

Ferramentas | Tools | Herramientas

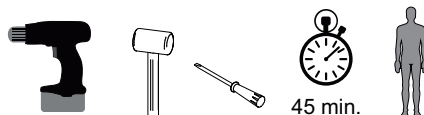

45 min.



Utilizar a régua abaixo para medir os componentes.

Medidas em mm

Revisão: 00
Data: 27/03/2024

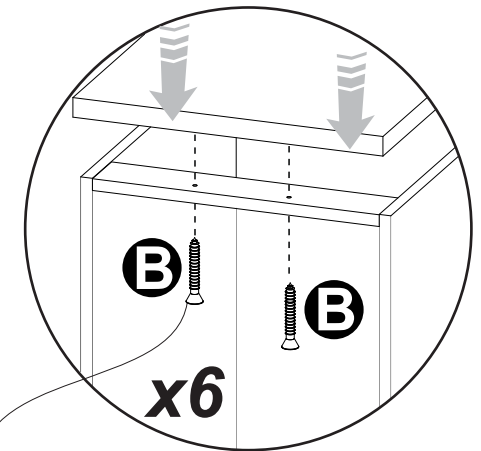
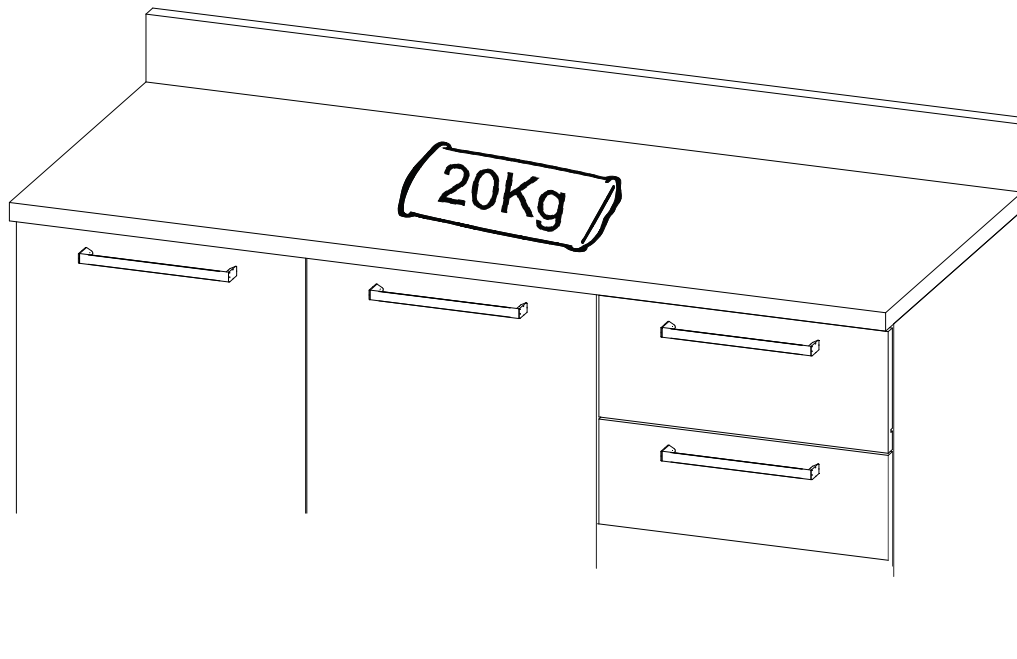
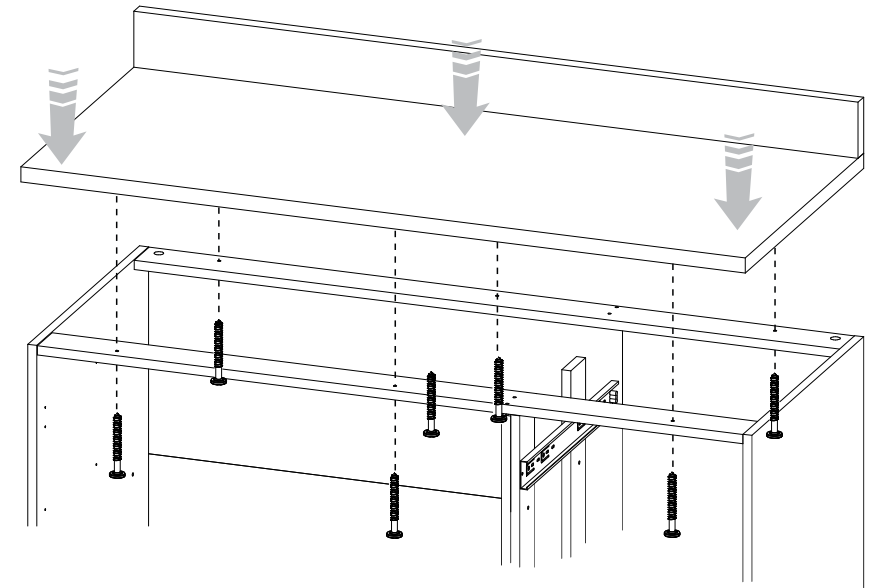
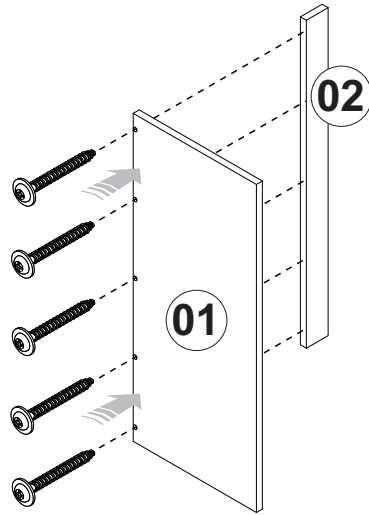
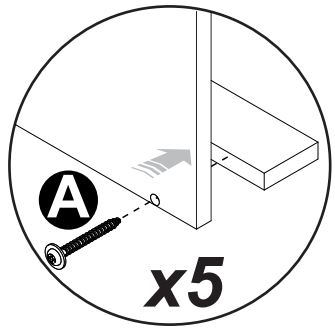

Utilizar o parafuso fornecido no kit do balcão
 Use the screw supplied in the balcony kit
 Utilice el tornillo suministrado en el kit de balcón

BALCAO 80

Instruções de Montagem Assembly Instructions Instrucciones de Montaje

Acesse Vídeos de Montagens
Access Mounting Videos
Acceder a los Vídeos de Montaje
www.tecnomobili.ind.br

tecnomobili

Estrada RSC 453, Km s/n° | Garibaldi | RS
CEP: 95720-000 | Fone / Fax: 54.3464.2050
sac@moveisvideira.com.br

Notas Especiais:

- 01** - Examine completamente todas as peças do móvel antes de começar o trabalho.
02 - Recomenda-se montar o móvel conforme este Manual de Montagem.
03 - É de responsabilidade do montador seguir as instruções do Manual de Montagem, que são fundamentais para garantir a estrutura do móvel.
04 - Para limpeza, utilizar somente pano úmido e sabão neutro.

Special notes:

- 01** - Check all parts of the unit thoroughly before starting work.
02 - It is recommended to assemble the furniture according to this Installation Manual.
03 - It is the responsibility of the assembler to follow the instructions in the Assembly Manual, which are essential to ensure the structure of the furniture.
04 - For cleaning use only damp cloth and neutral soap.

Notas especiales:

- 01** - Examine completamente todas las piezas del mueble antes de iniciar el trabajo.
02 - Se recomienda montar el mueble conforme el Manual de Ensamblaje.
03 - Es de responsabilidad del montador seguir las instrucciones del Manual de Ensamblaje, que son fundamentales para garantizar la estructura del mueble.
04 - Para limpieza solamente usar trapo húmedo y jabón neutro.

Guarante certificate:

The guarantee of products manufactured by Móveis Videira LTDA covers any defects / manufacturing defects, within the period established by the Consumer Protection Code, in its Article 26, II, which provides for a legal guarantee of ninety (90) days.



Lista de Peças / List of pieces / Lista de piezas

Cód	DESCRIÇÃO	DESCRIPTION	DESCRIPCIÓN	QTD	RAW MATERIAL	DIMENSION	CÓD
01	Base	Base	Base	1	MDP 15mm	798x490x15mm	101101
02	Lateral Esquerda	Left Side	Lateral Izquierda	1	MDP 15mm	665x490x15mm	301102
03	Lateral Direita	Right Side	Lateral Derecha	1	MDP 15mm	665x490x15mm	311102
04	Travessa Frontal	Front Rail	Traviesa Frontal	1	MDP 15mm	768x65x15mm	611101
05	Travessa Traseira	Rear crossbar	Traviesa traseira	1	MDP 15mm	768x65x15mm	621101
06	Costa	Back	Costa	2	MDP 03mm	788x335x03mm	421101
07	Prateleira	Shelf	Estante	1	MDP 15mm	768x385x15mm	201100
08	Porta	Door	Puerta	2	MDP 15mm	670x396x15mm	81100

ATENÇÃO

Se necessário, utilizar parafuso B para junção de tampo

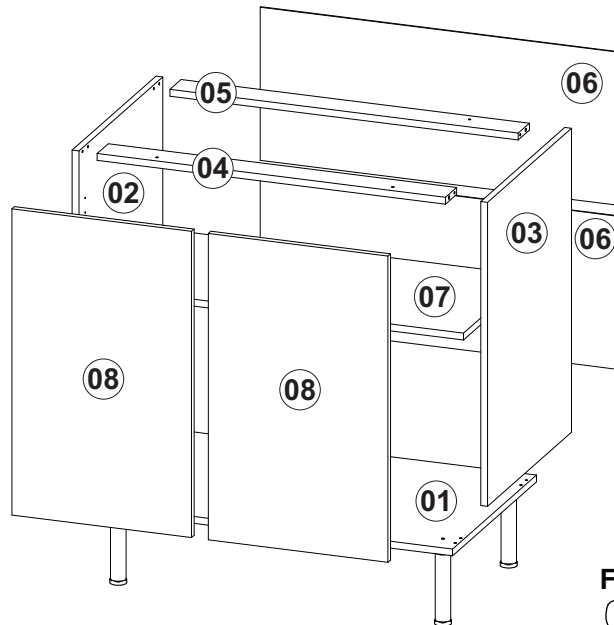

Ferramentas | Tools | Herramientas

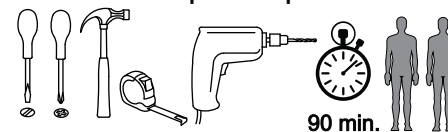

Revisão: 01
Data: 06/08/2024

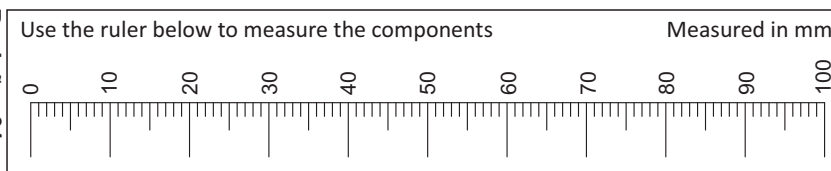

TAMANHO REAL - TAMAÑO VERDADERO - REAL SIZE

REF	DESCRIÇÃO	QTD	CÓD
A	3,5x14mm CC	30	3639
B	3,5x25mm CP	08	9623
C	Cavilha 5 x 30mm	08	3880
D	5,0x40mm CC	04	4000
E	5x45mm CF	02	2605

ILUSTRAÇÃO - ILUSTRACION - ILLUSTRATION

REF	DESCRIÇÃO	QTD	CÓD
F	22x3mm Prego 10x10	28	3051
G	Puxador Aleno FIT 192 entre furos	02	
H	34x7mm Parafuso minifix	04	3771
I	15x12mm Tambor minifix	04	9516
J	Dobradiça Reta C/Amortecedor Caneco 35mm	04	9934
K	40x8mm Bucha 8mm	02	5623
L	3,5x25mm CC	02	0286
M	3,5x40mm CC	04	8115
N	Adesivo Tapa Furo	04	
O	Pé Plástico 170mm Com Detalhe Cromado	04	
P	43x43x25mm Cantoneira com Capa	02	5630
Q	14x8x5mm Suporte Prateleira 5x8 c/ estria	04	3748

1

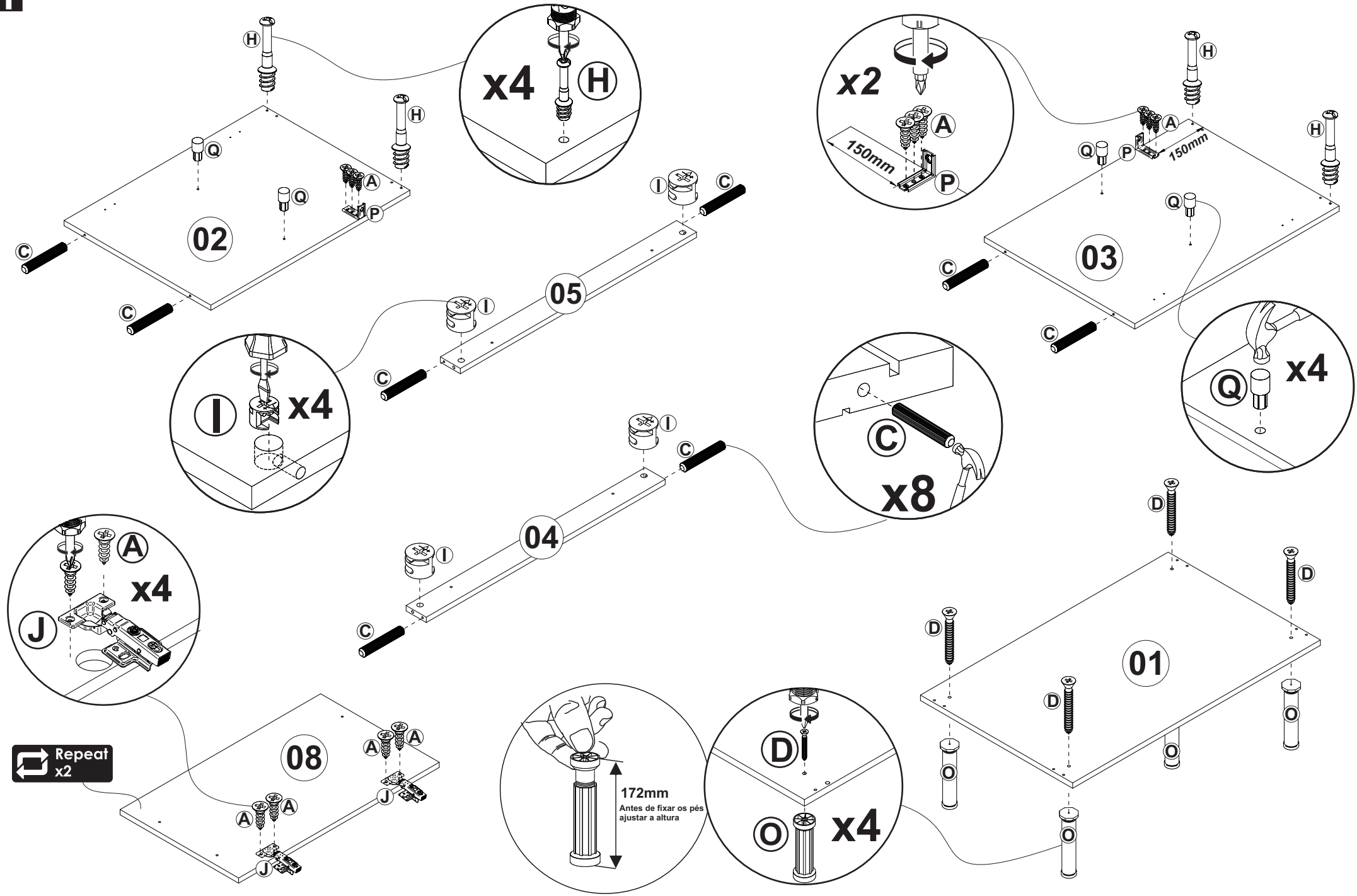

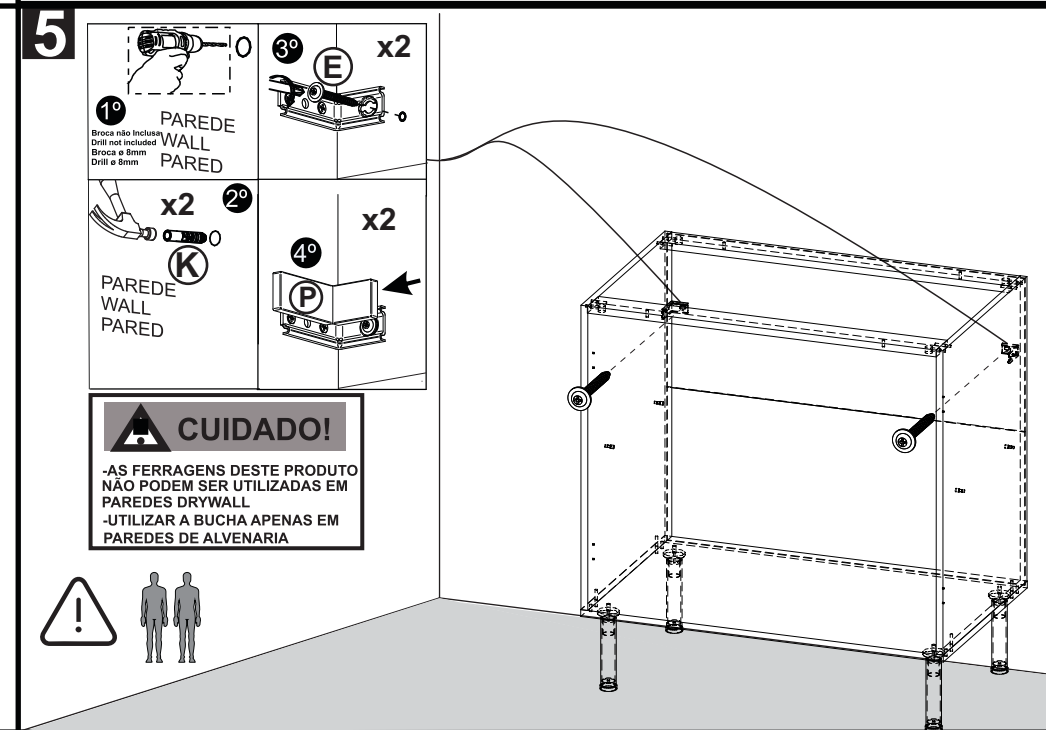
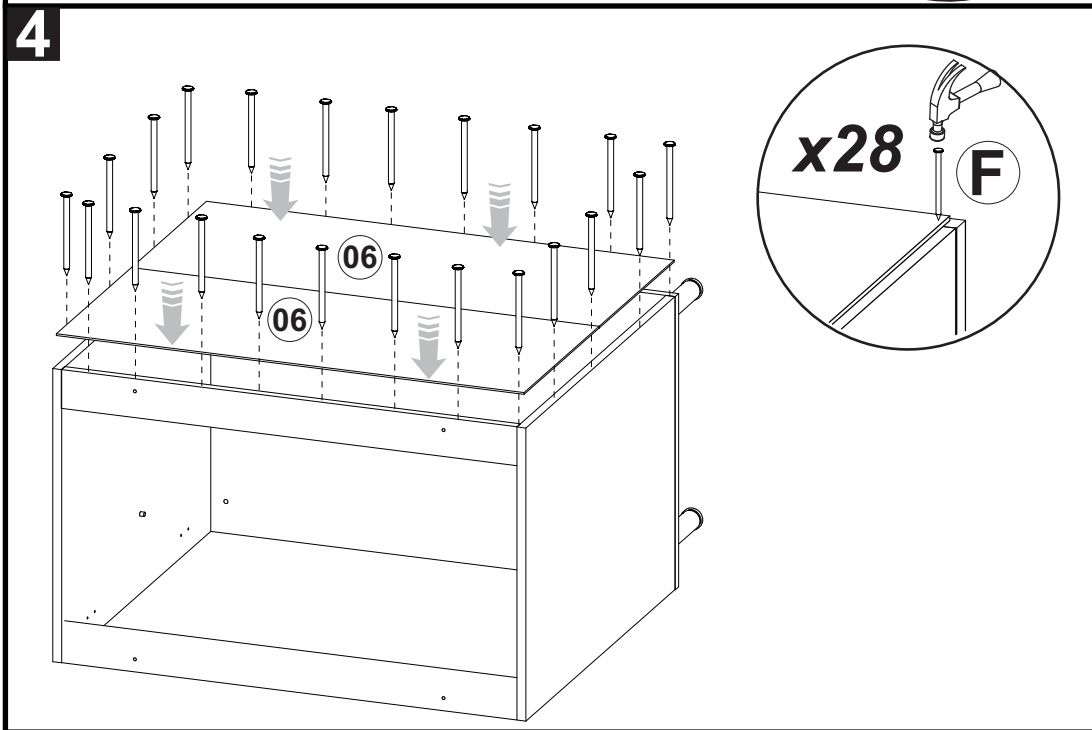
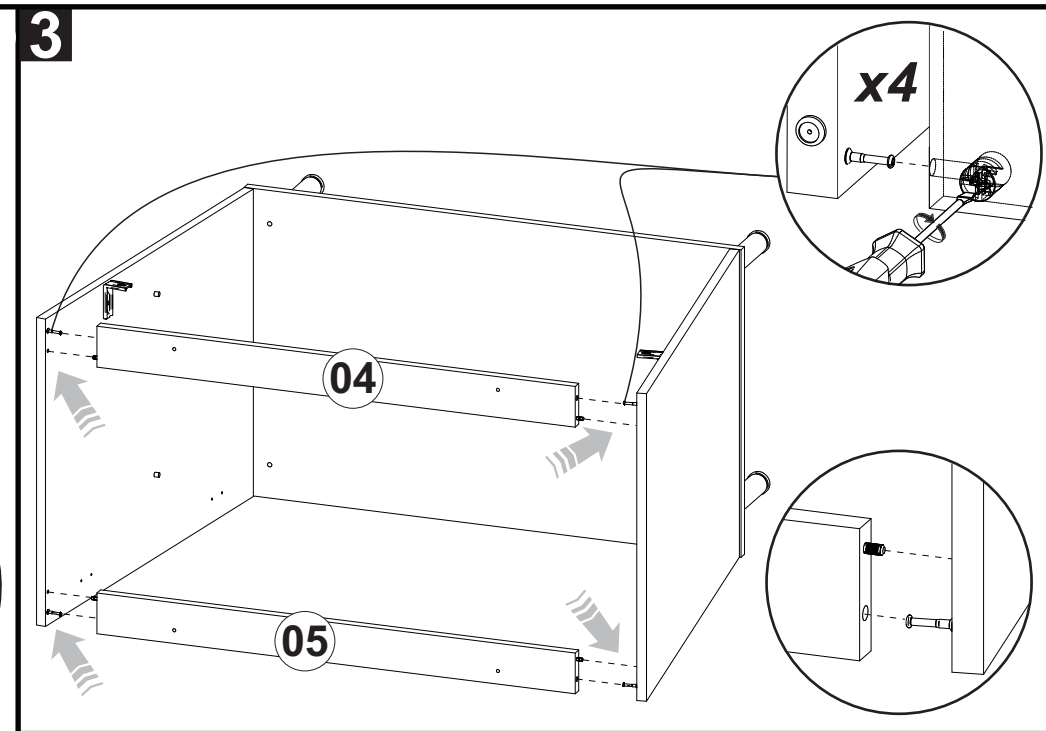
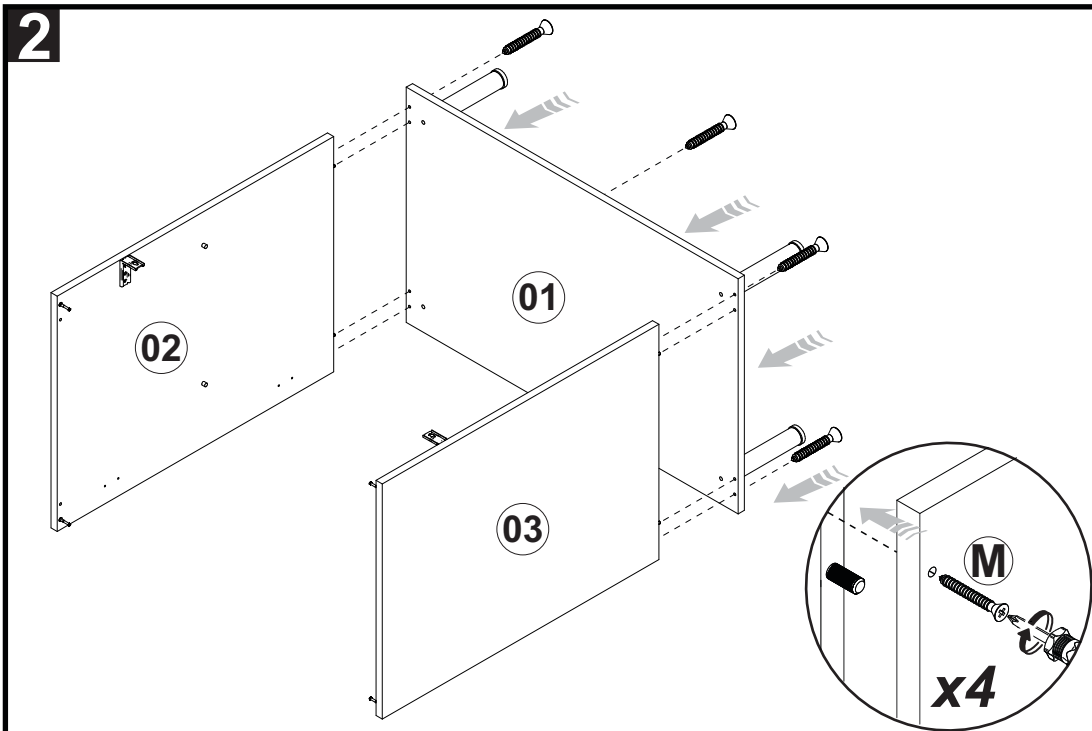

6



7

Ajuste das Portas- Ajustes de las Puertas- Doors Adjustment

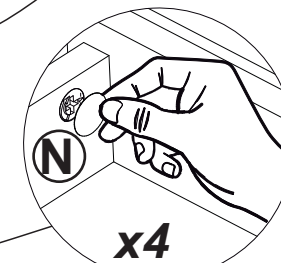
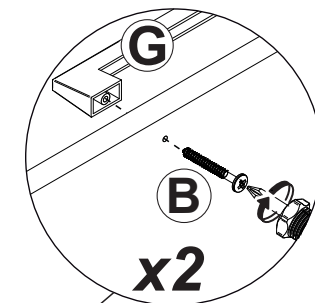
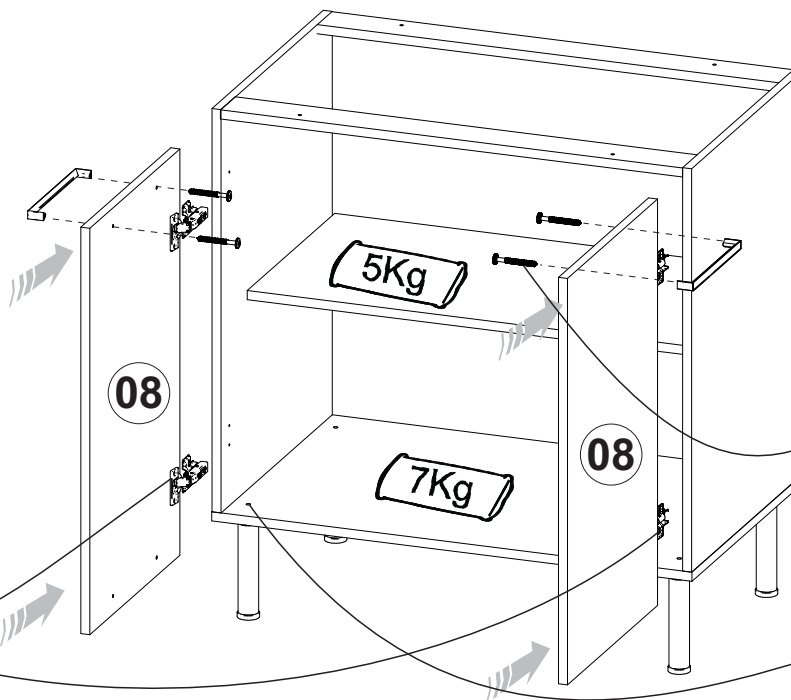
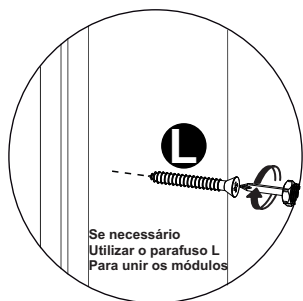
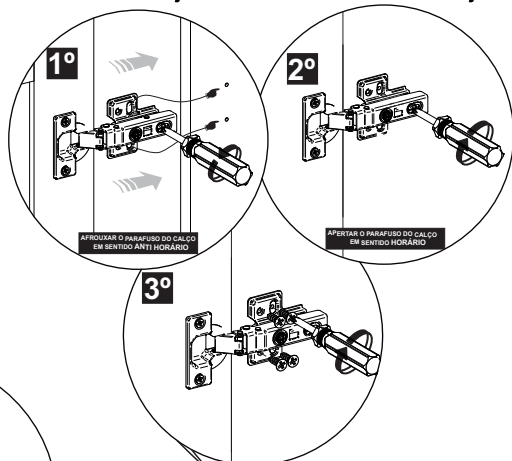

TAMPO 80

Instruções de Montagem Assembly Instructions Instrucciones de Armado

Acesse Vídeos de Montagens
Access Mounting Videos
Acceder a los Vídeos de Montaje
www.tecnomobili.ind.br

tecnomobili

Estrada RSC 453, Km s/n° | Garibaldi | RS
CEP: 95720-000 | Fone / Fax: 54.3464.2050
sac@moveisvideira.com.br

Notas Especiais:

01 -Examine completamente todas as peças do móvel antes de começar o trabalho.

02 -Recomenda-se montar o móvel conforme este Manual de Montagem.

03 -É de responsabilidade do montador seguir as instruções do Manual de Montagem, que são fundamentais para garantir a estrutura do móvel.

04 -Para limpeza, utilizar somente pano úmido e sabão neutro.

Special notes:

01 -Check all parts of the unit thoroughly before starting work.

02 -It is recommended to assemble the furniture according to this Installation Manual.

to follow the instructions in the Assembly Manual, which are essential to ensure the structure of the furniture.

04 -For cleaning use only damp cloth and neutral soap.

Notas especiales:

01 -Examine completamente todas las piezas del mueble antes de iniciar el trabajo.

02 -Se recomienda montar el mueble conforme el Manual de Ensamblaje.

03 -Es de responsabilidad del montador seguir las instrucciones del Manual de Ensamblaje, que son fundamentales para garantizar la estructura del mueble.

04 - Para limpieza solamente usar trapo húmedo y jabón neutro.

Guarante certificate:

Móveis Videira LTDA covers any defects / manufacturing defects, within the period established by the Consumer Protection

legal guarantee of ninety (90) days.



Lista de Peças / List of pieces / Lista de piezas

Cód	DESCRIÇÃO	DESCRIPTION	DESCRIPCION	QTD	RAW MATERIAL	DIMENSION	CÓD
01	Tampo	Top	Tapa	1	MDP 25mm	799x520x25mm	701114
02	Espelho	Mirror	Espejo	1	MDP 25mm	799x92x25mm	601121

TAMANHO REAL - TAMAÑO VERDADERO - REAL SIZE

REF	DESCRIÇÃO	QTD	CÓD
A	 Parafuso 4,0 x 45mm CF	04	9510

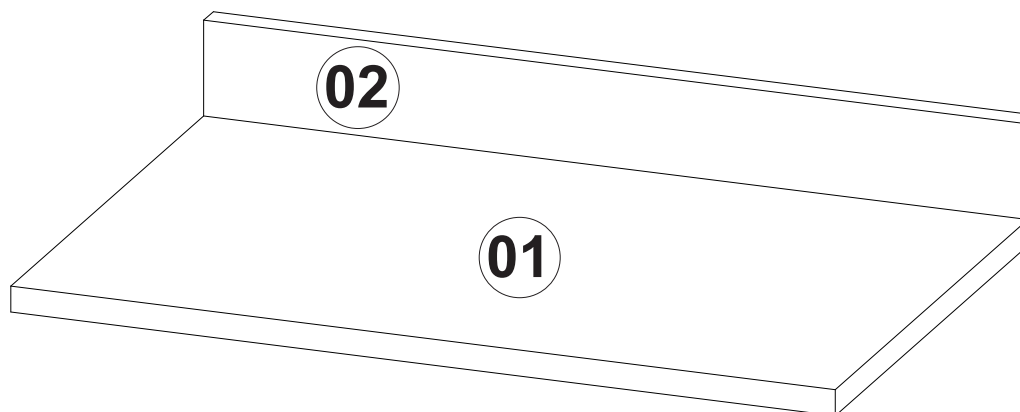

Ferramentas | Tools | Herramientas



45 min.



Revisão: 00
Data: 27/03/2024

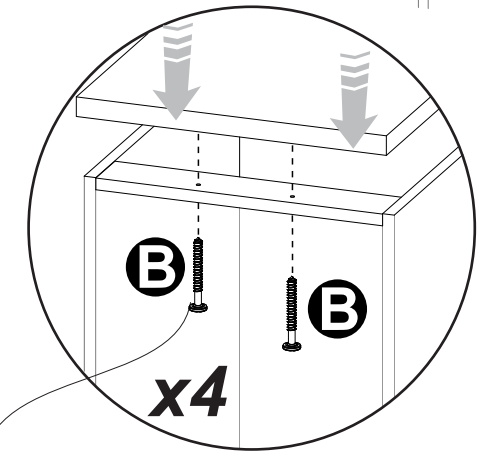
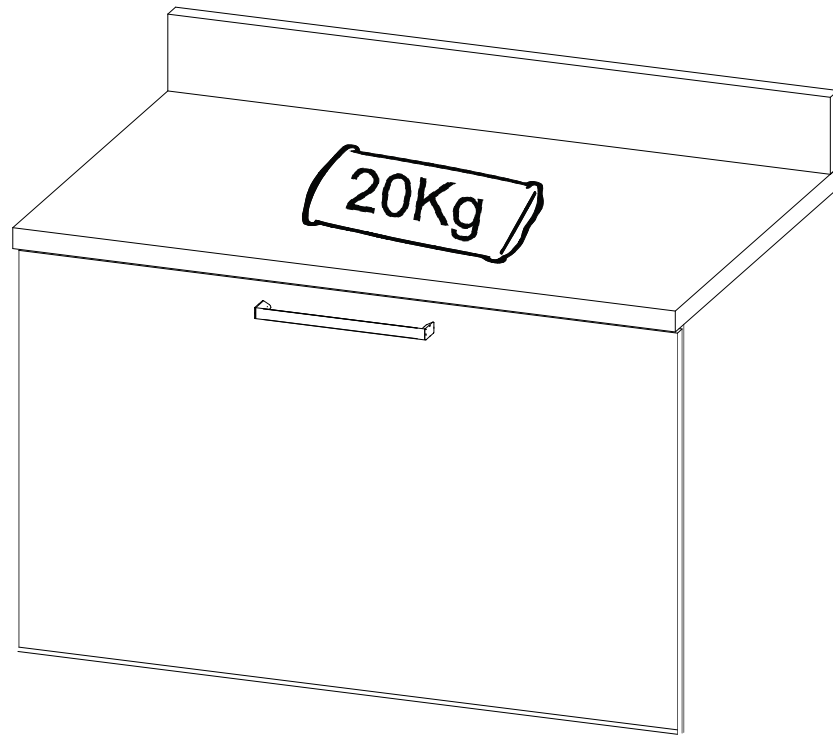
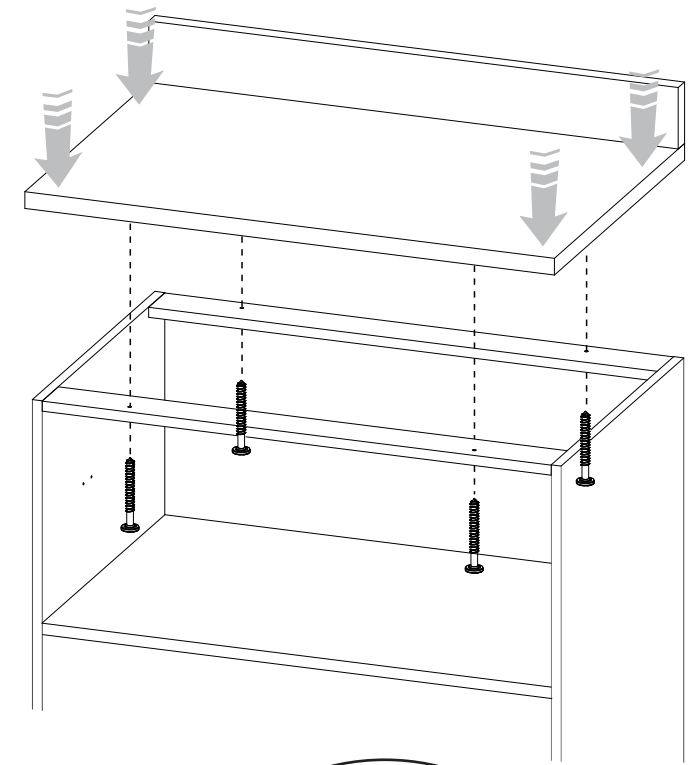
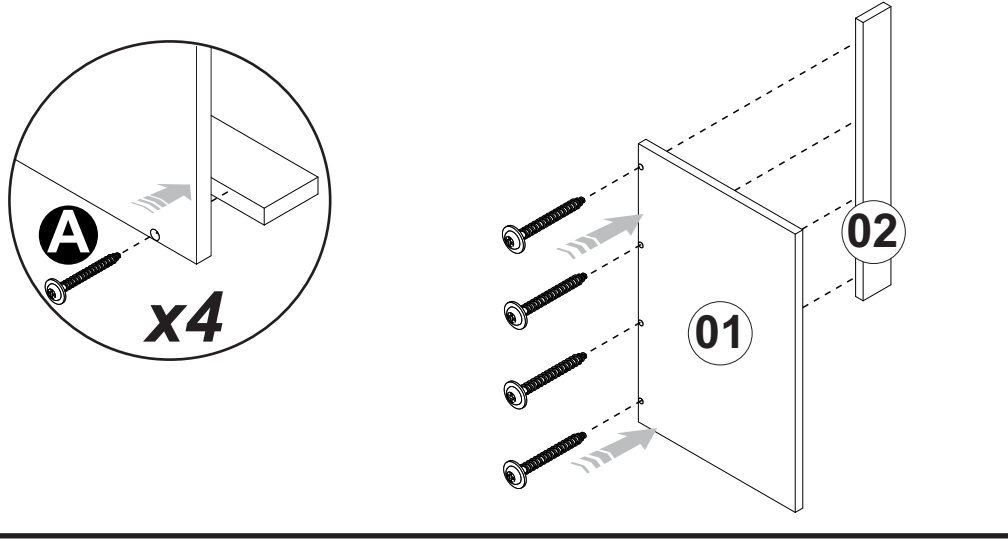

Utilizar o parafuso fornecido no kit do balcão
 Use the screw supplied in the balcony kit
 Utilice el tornillo suministrado en el kit de balcón

AEREO 120

Instruções de Montagem Assembly Instructions Instrucciones de Montaje

Acesse Vídeos de Montagens
Access Mounting Videos
Acceder a los Vídeos de Montaje
www.tecnomobili.ind.br

tecnomobili

Estrada RSC 453, Km s/n° | Garibaldi | RS
CEP: 95720-000 | Fone / Fax: 54.3464.2050
sac@moveisvideira.com.br

Notas Especiais:

- 01** - Examine completamente todas as peças do móvel antes de começar o trabalho.
02 - Recomenda-se montar o móvel conforme este Manual de Montagem.
03 - É de responsabilidade do montador seguir as instruções do Manual de Montagem, que são fundamentais para garantir a estrutura do móvel.
04 - Para limpeza, utilizar somente pano úmido e sabão neutro.

Special notes:

- 01** - Check all parts of the unit thoroughly before starting work.
02 - It is recommended to assemble the furniture according to this Installation Manual.
03 - It is the responsibility of the assembler to follow the instructions in the Assembly Manual, which are essential to ensure the structure of the furniture.
04 - For cleaning use only damp cloth and neutral soap.

Notas especiales:

- 01** - Examine completamente todas las piezas del mueble antes de iniciar el trabajo.
02 - Se recomienda montar el mueble conforme el Manual de Ensamblaje.
03 - Es de responsabilidad del montador seguir las instrucciones del Manual de Ensamblaje, que son fundamentales para garantizar la estructura del mueble.
04 - Para limpieza solamente usar trapo húmedo y jabón neutro.

Guarante certificate:

The guarantee of products manufactured by Móveis Videira LTDA covers any defects / manufacturing defects, within the period established by the Consumer Protection Code, in its Article 26, II, which provides for a legal guarantee of ninety (90) days.

Lista de Peças / List of pieces / Lista de piezas

CóD	DESCRIÇÃO	DESCRIPTION	DESCRIPCIÓN	QTD	RAW MATERIAL	DIMENSION	CÓD
01	Divisão	Division	División	1	MDP 15mm	769x300x15mm	501109
02	Base	Base	Base	2	MDP 15mm	1169x300x15mm	101109
03	Lateral Esquerda	Left Side	Lateral Izquierda	1	MDP 15mm	800x300x15mm	301110
04	Lateral Direita	Right Side	Lateral Derecha	1	MDP 15mm	800x300x15mm	311110
05	Costa	Back	Costa	3	MDP 03mm	790x395x03mm	401106
06	Prateleira Movei	Shelf Mobile	Prateleira Mobil	1	MDP 15mm	381x255x15mm	211109
07	Prateleira Movei Maior	Larger Shelf Mobile	Prateleira Mobil Major	1	MDP 15mm	772x255x15mm	201109
08	Porta	Door	Puerta	3	MDP 15mm	794x396x15mm	91118

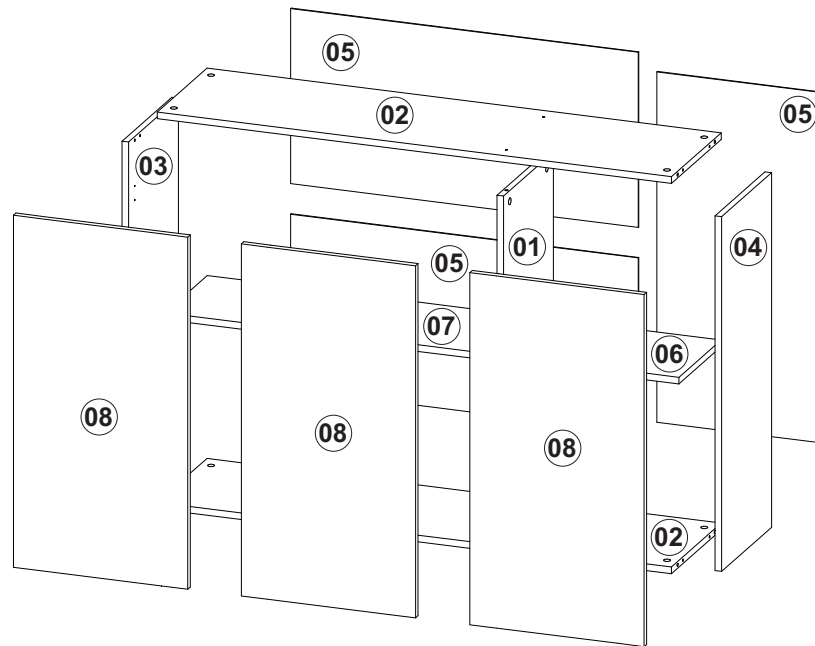

TAMANHO REAL - TAMAÑO VERDADERO - REAL SIZE

REF	DESCRIÇÃO	QTD	CÓD
A	3,5x14mm CC	48	3639
B	3,5x25mm CP	06	9623
C	Cavilha 5 x 30mm	08	3880
D	5x45mm CF	04	2605

LUSTRACÃO - ILUSTRACION - ILLUSTRATION

REF	DESCRIÇÃO	QTD	CÓD
E	22x3mm Prego 10x10	45	3051
F	Puxador Aleno FIT 192 entre furos	03	
G	34x7mm Parafuso minifix	12	3771
H	15x12mm Tambor minifix	12	9516
I	Dobradiça Reta C/Amortecedor Caneco 35mm	06	9934
J	40x8mm Buchta 8mm	04	5623
K	3,5x25mm CC	02	0286
L	Adesivo Tapa Furo	10	
M	43x43x25mm Cantoneira com Capa	04	5630
N	14 x 8 x 5mm Suporte de Prateleira	08	3748
O	13 x 13 x 3mm Fixador de Costa	05	6524



Ferramentas | Tools | Herramientas

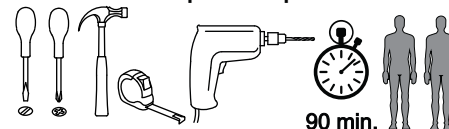

Revisão: 00
Data: 29/02/2024

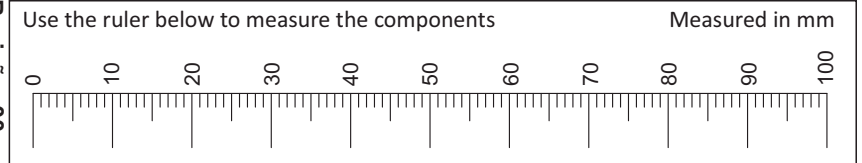

1

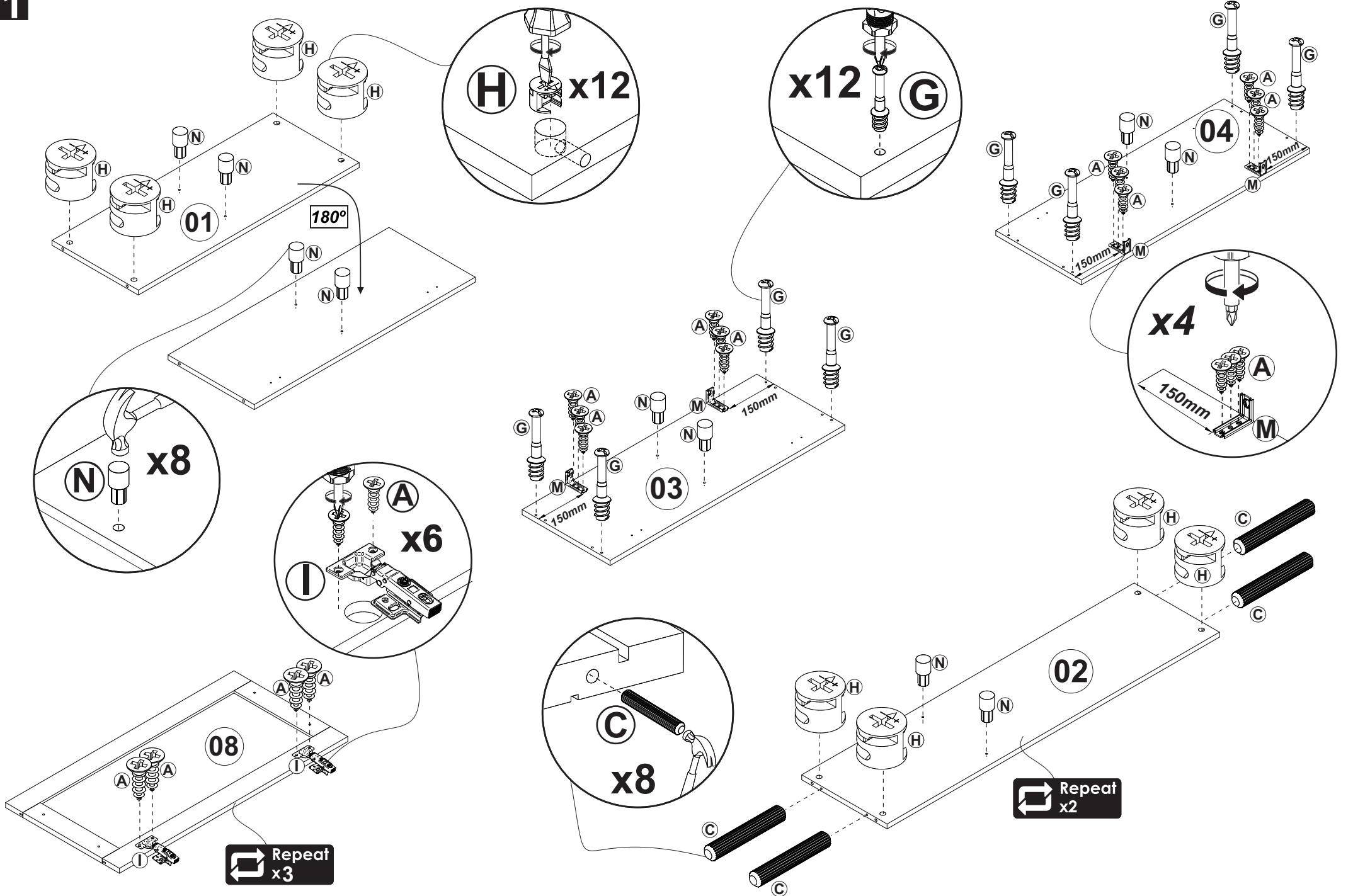

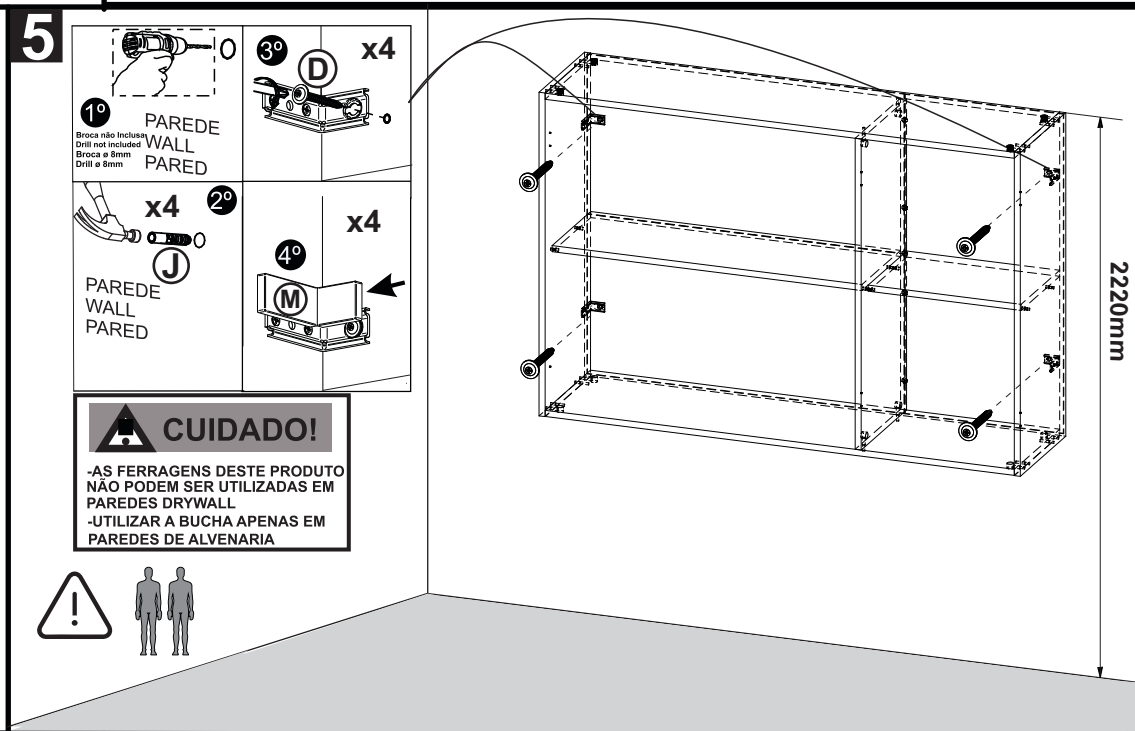
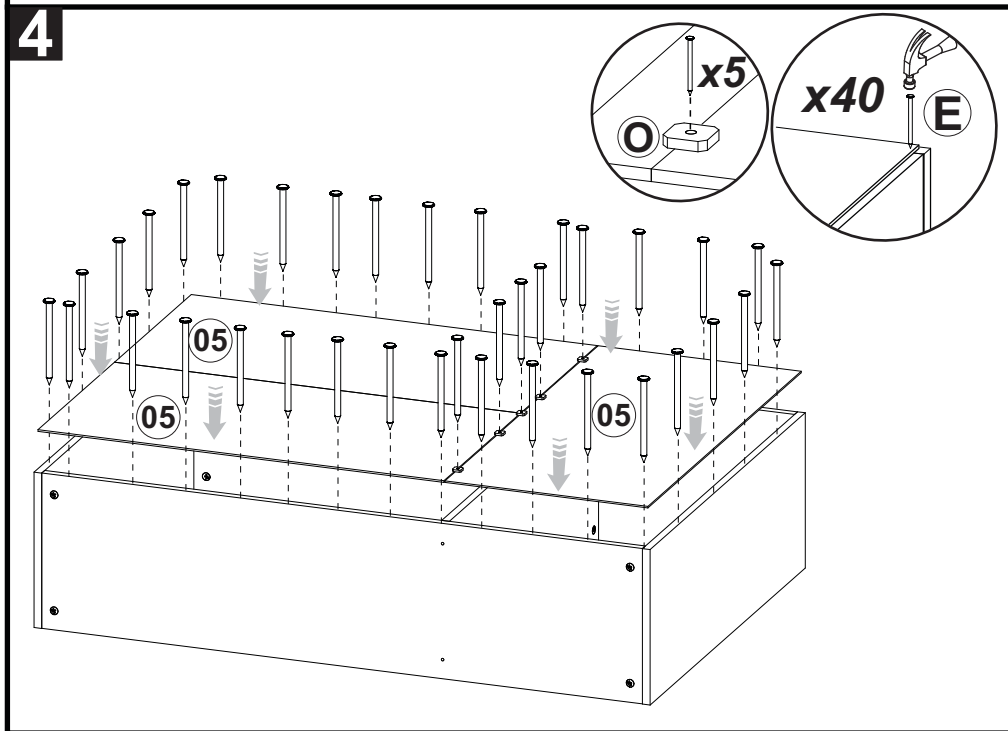
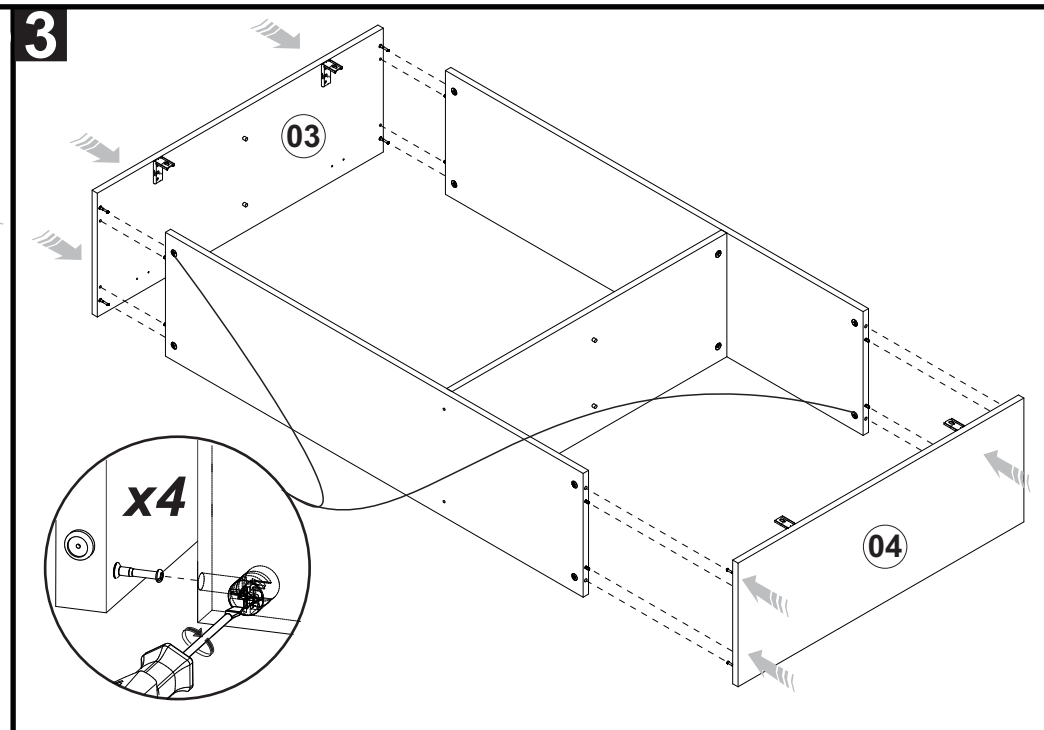
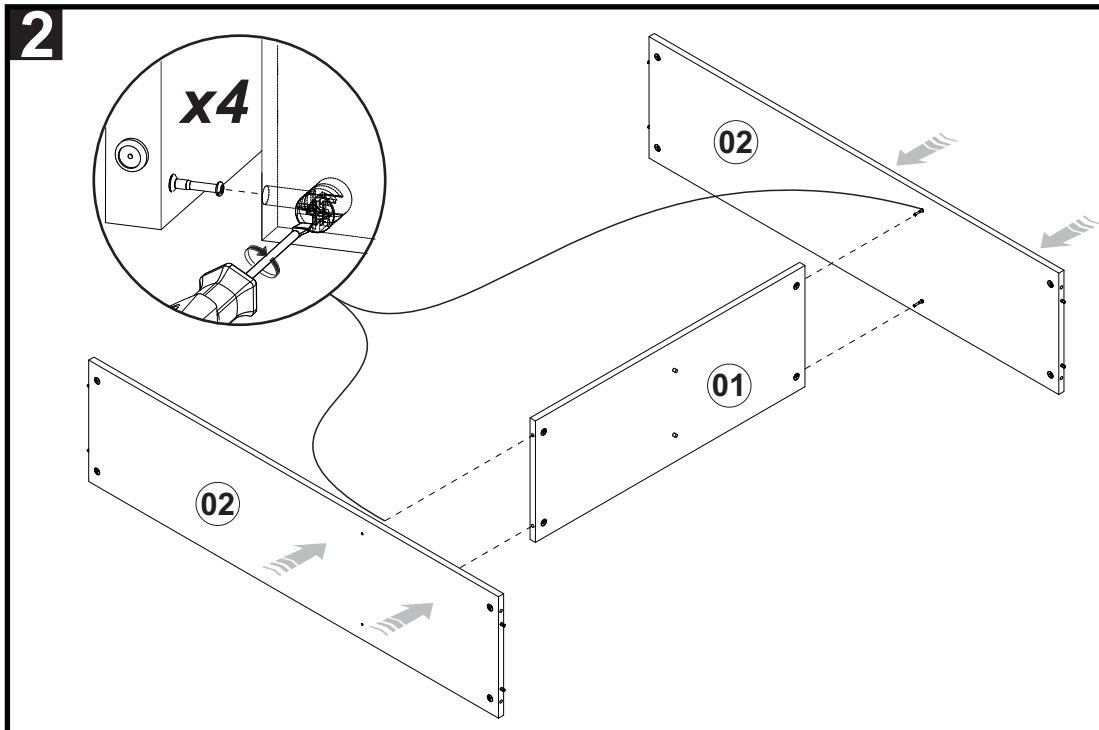

6

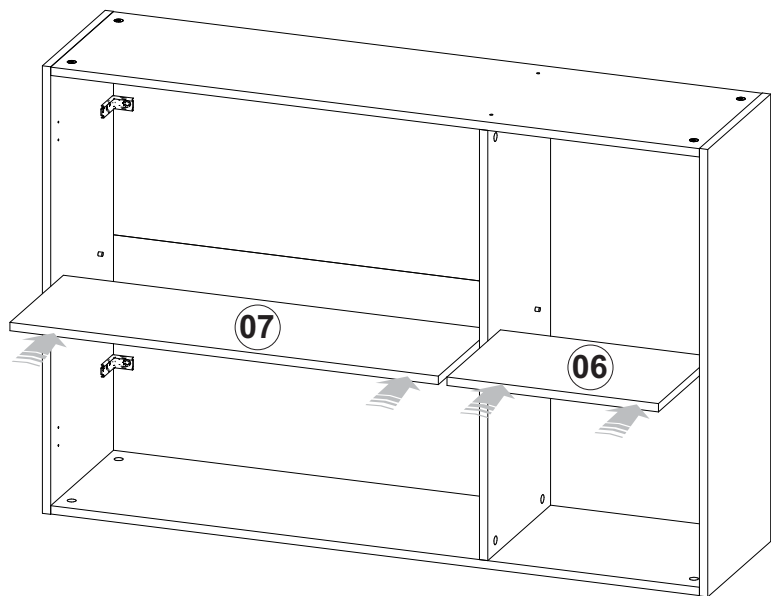

7

Ajuste das Portas - Ajustes de las Puertas - Doors Adjustment

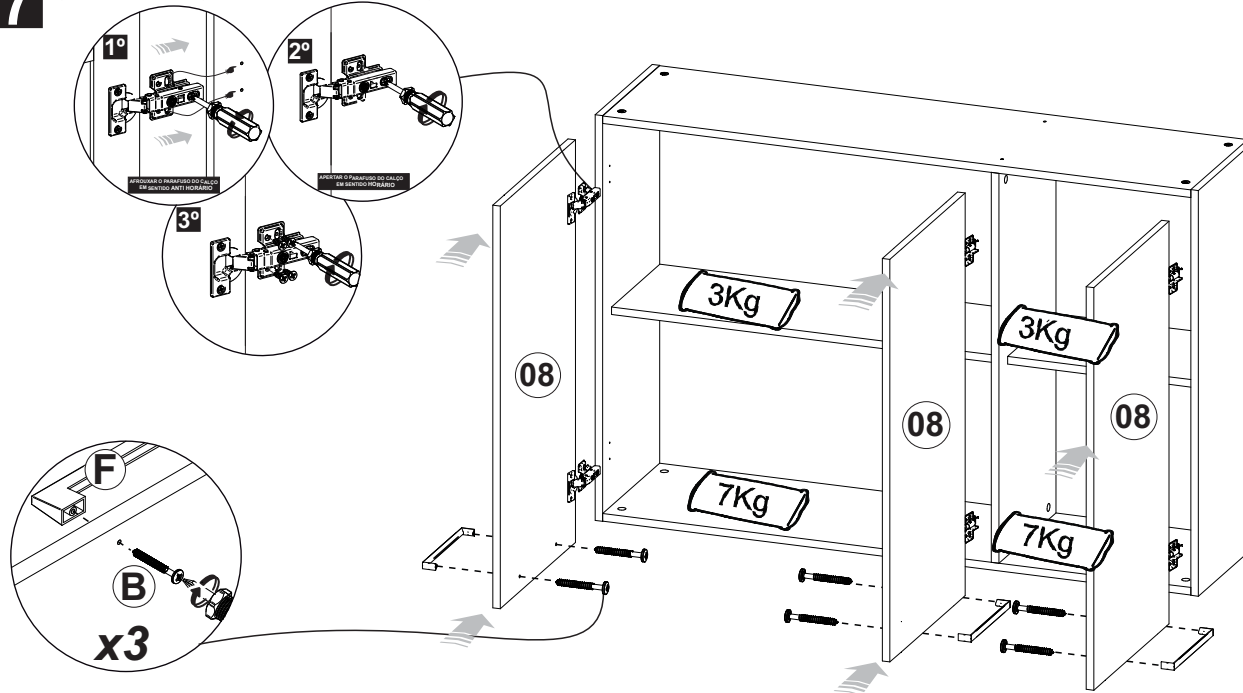

8

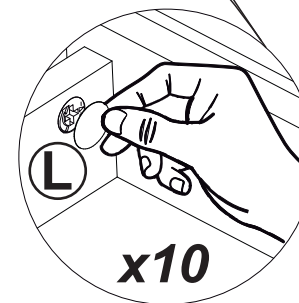
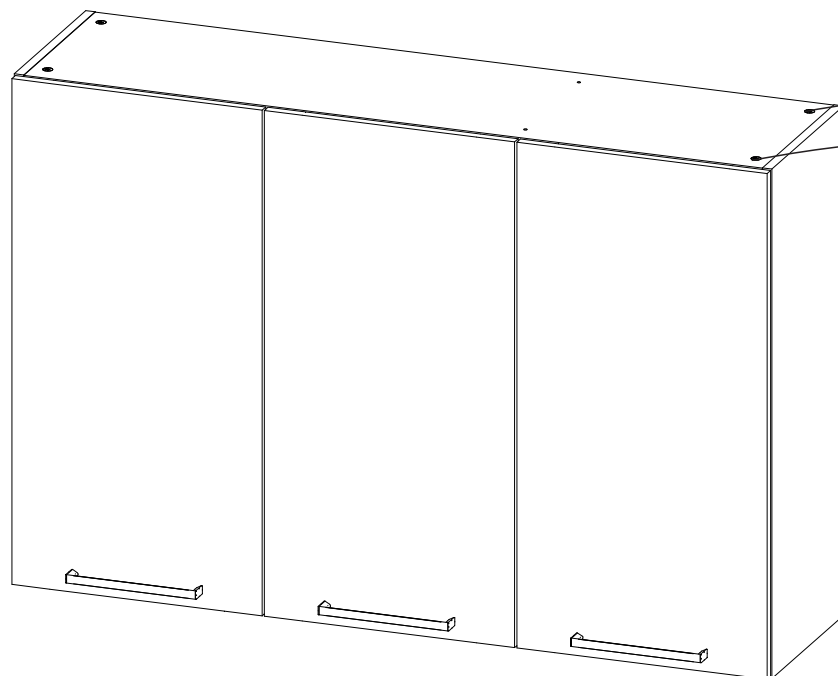
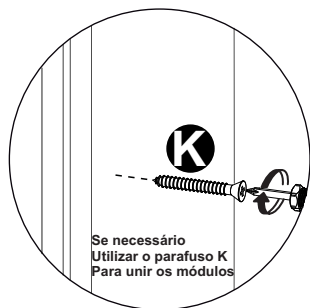

AEREO 80

Instruções de Montagem Assembly Instructions Instrucciones de Montaje

Acesse Vídeos de Montagens
Access Mounting Videos
Acceder a los Vídeos de Montaje
www.tecnomobili.ind.br

tecnomobili

Estrada RSC 453, Km s/n° | Garibaldi | RS
CEP: 95720-000 | Fone / Fax: 54.3464.2050
sac@moveisvideira.com.br

Notas Especiais:

01 - Examine completamente todas as peças do móvel antes de começar o trabalho.

02 - Recomenda-se montar o móvel conforme este Manual de Montagem.

03 - É de responsabilidade do montador seguir as instruções do Manual de Montagem, que são fundamentais para garantir a estrutura do móvel.

04 - Para limpeza, utilizar somente pano úmido e sabão neutro.

Special notes:

01 - Check all parts of the unit thoroughly before starting work.

02 - It is recommended to assemble the furniture according to this Installation Manual.

03 - It is the responsibility of the assembler to follow the instructions in the Assembly Manual, which are essential to ensure the structure of the furniture.

04 - For cleaning use only damp cloth and neutral soap.

Notas especiales:

01 - Examine completamente todas las piezas del mueble antes de iniciar el trabajo.

02 - Se recomienda montar el mueble conforme el Manual de Ensamblaje.

03 - Es de responsabilidad del montador seguir las instrucciones del Manual de Ensamblaje, que son fundamentales para garantizar la estructura del mueble.

04 - Para limpieza solamente usar trapo húmedo y jabón neutro.

Guarante certificate:

The guarantee of products manufactured by Móveis Videira LTDA covers any defects / manufacturing defects, within the period established by the Consumer Protection Code, in its Article 26, II, which provides for a legal guarantee of ninety (90) days.

Lista de Peças / List of pieces / Lista de piezas

CóD	DESCRIÇÃO	DESCRIPTION	DESCRIPCIÓN	QTD	RAW MATERIAL	DIMENSION	CÓD
01	Lateral Esquerda	Left Side	Lateral Izquierda	1	MDP 15mm	800x300x15mm	301110
02	Base	Base	Base	2	MDP 15mm	769x300x15mm	101106
03	Lateral Direita	Right Side	Lateral Derecha	1	MDP 15mm	800x300x15mm	311110
04	Costa	Back	Costa	2	MDP 03mm	790x395x03mm	401106
05	Prateleira Movei	Shelf Mobile	Prateleira Mobil	1	MDP 15mm	769x255x15mm	201115
06	Porta	Door	Puerta	2	MDP 15mm	794x396x15mm	81118

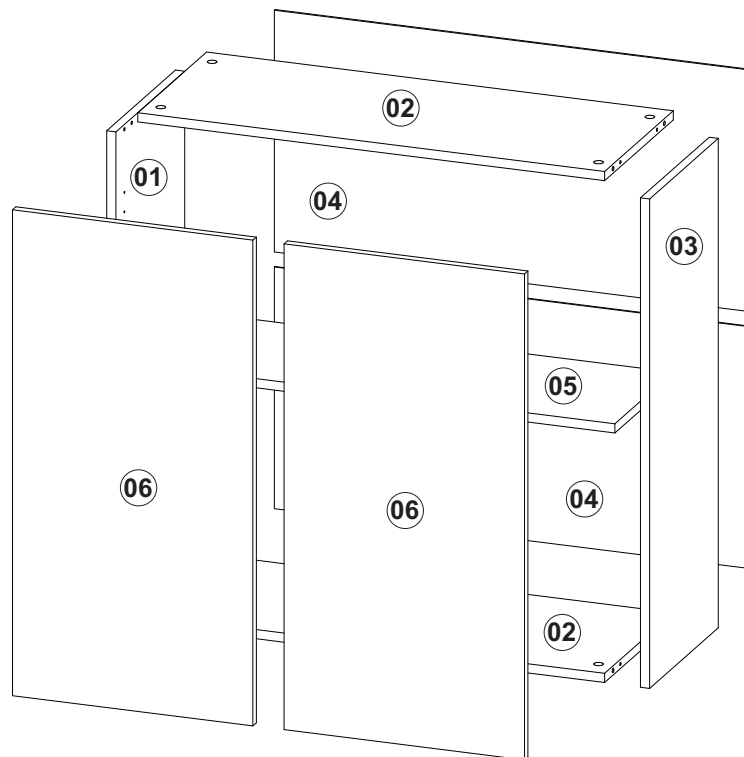

TAMANHO REAL - TAMANO VERDADERO - REAL SIZE

REF	DESCRIÇÃO	QTD	CÓD
A	3,5x14mm CC	36	3639
B	3,5x25mm CP	04	9623
C	Cavilha 5 x 30mm	08	3880
D	3,5x25mm CC	02	0286
E	5x45mm CF	04	2605

LUSTRAÇÃO - ILUSTRACION - ILLUSTRATION

REF	DESCRIÇÃO	QTD	CÓD
F	22x3mm Prego 10x10	30	3051
G	Puxador Aleno FIT 192 entre furos	02	
H	34x7mm Parafuso minifix	08	3771
I	15x12mm Tambor minifix	08	9516
J	Dobradiça Reta C/Amortecedor Caneco 35mm	04	9934
K	40x8mm Bucha 8mm	04	5623
L	Adesivo Tapa Furo	04	
M	43x43x25mm Cantoneira com Capa	04	5630
N	14x8x5mm Suporte Prateleira 5x8 c/ estria	04	3748



Ferramentas | Tools | Herramientas

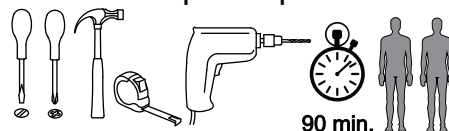

Revisão: 00
Data: 29/02/2024

Use the ruler below to measure the components Measured in mm

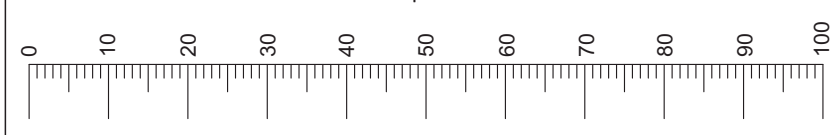

1

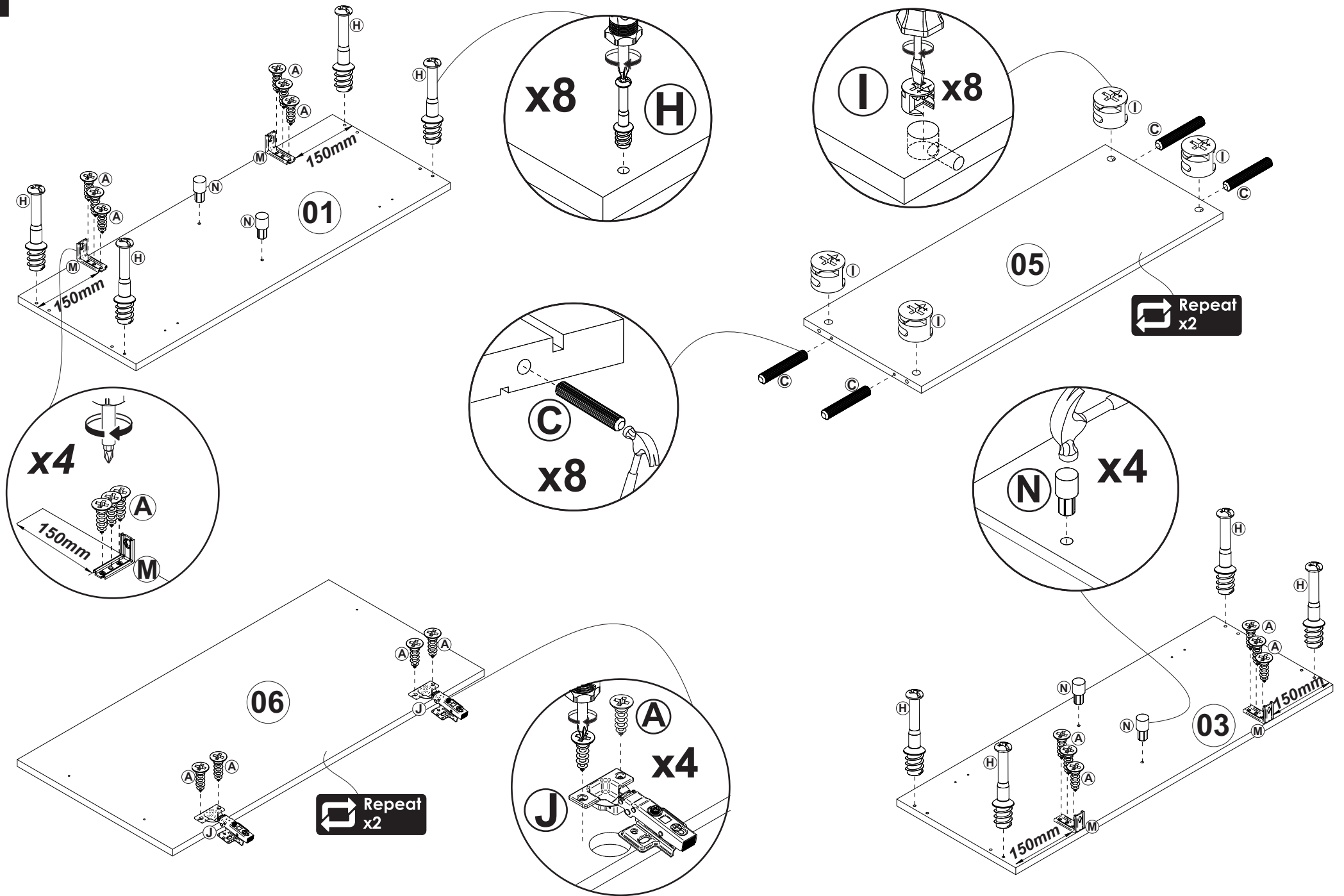

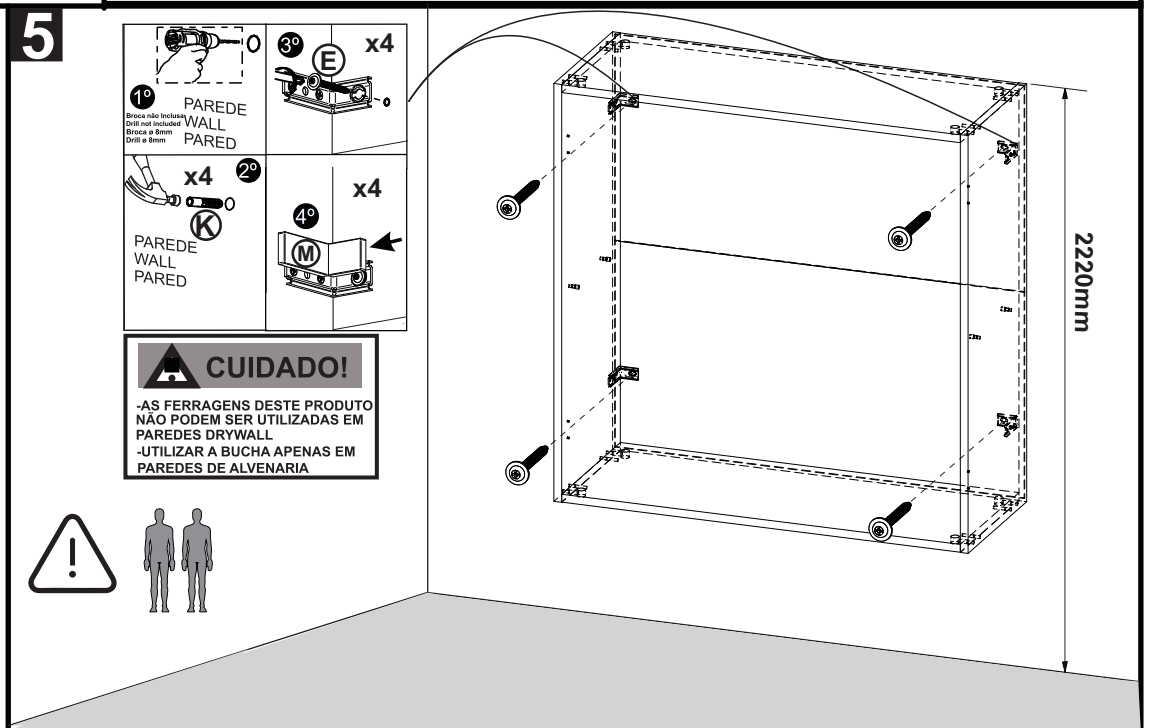
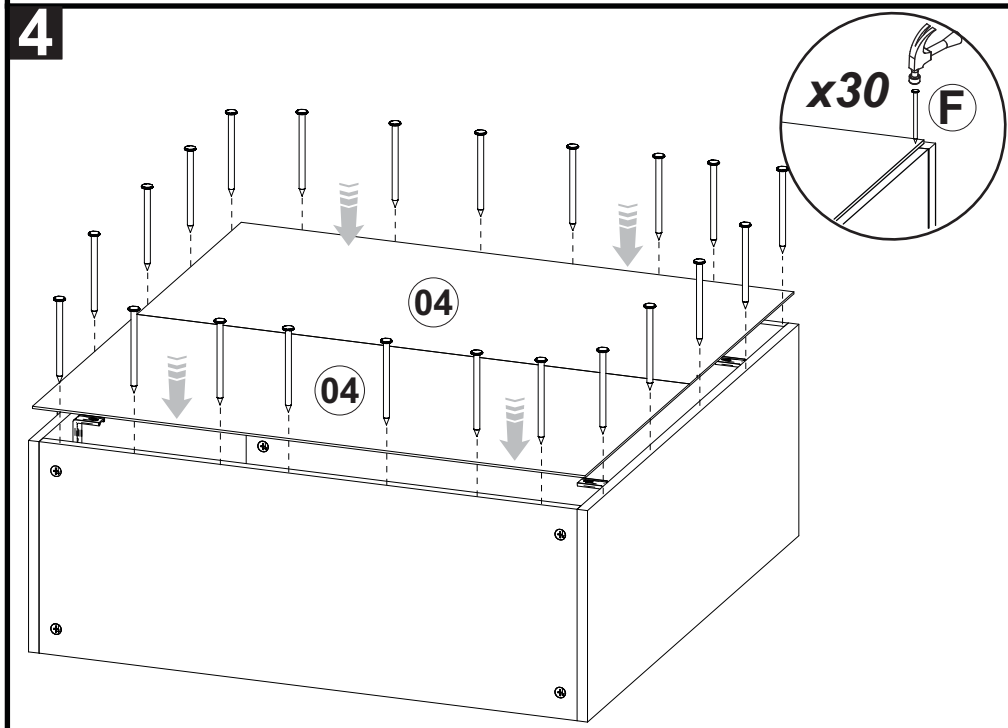
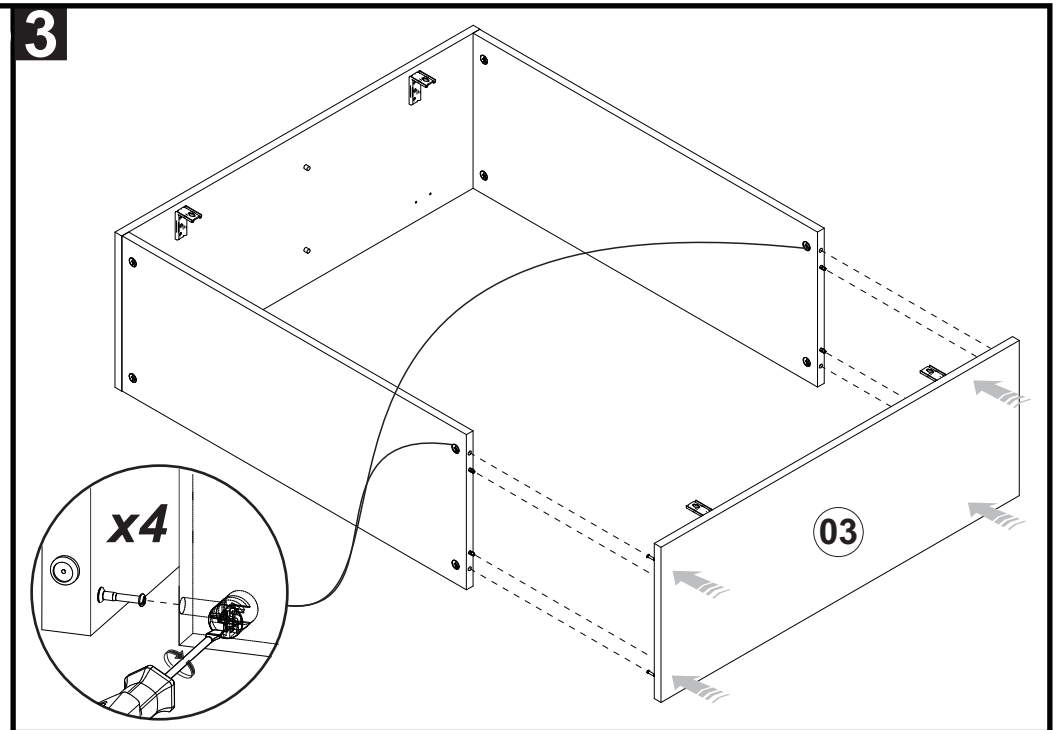
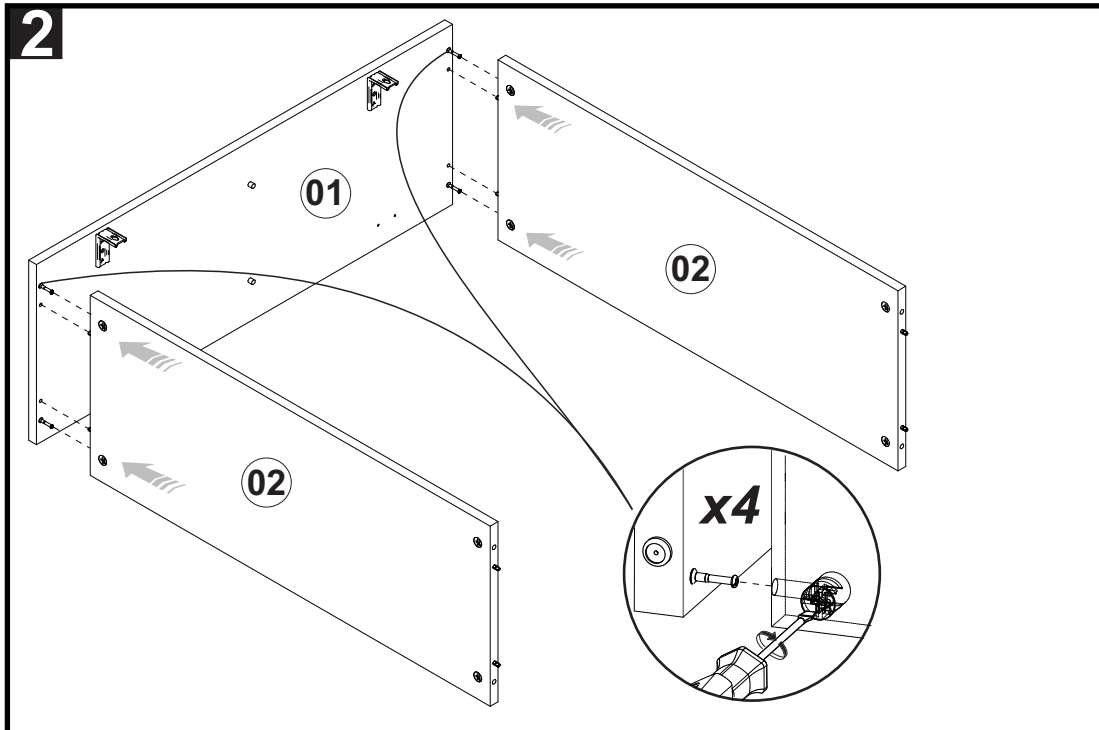

6

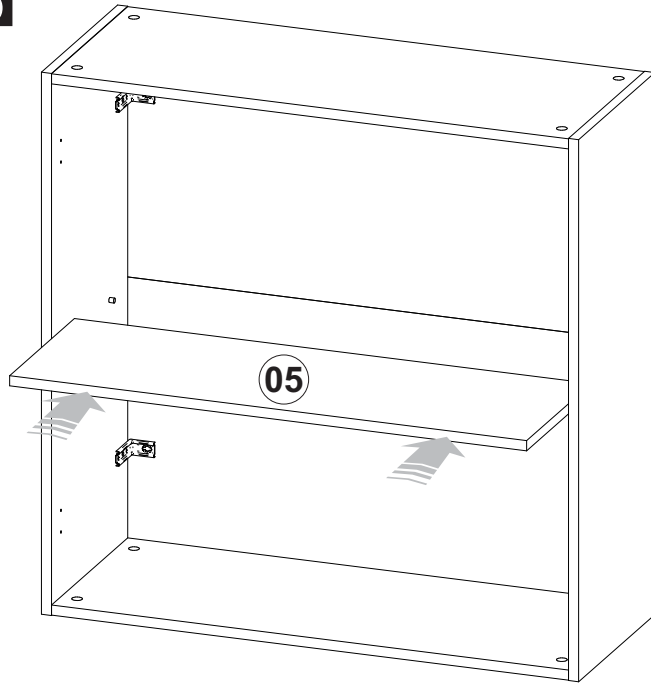

7

Ajuste das Portas- Ajustes de las Puertas- Doors Adjustment

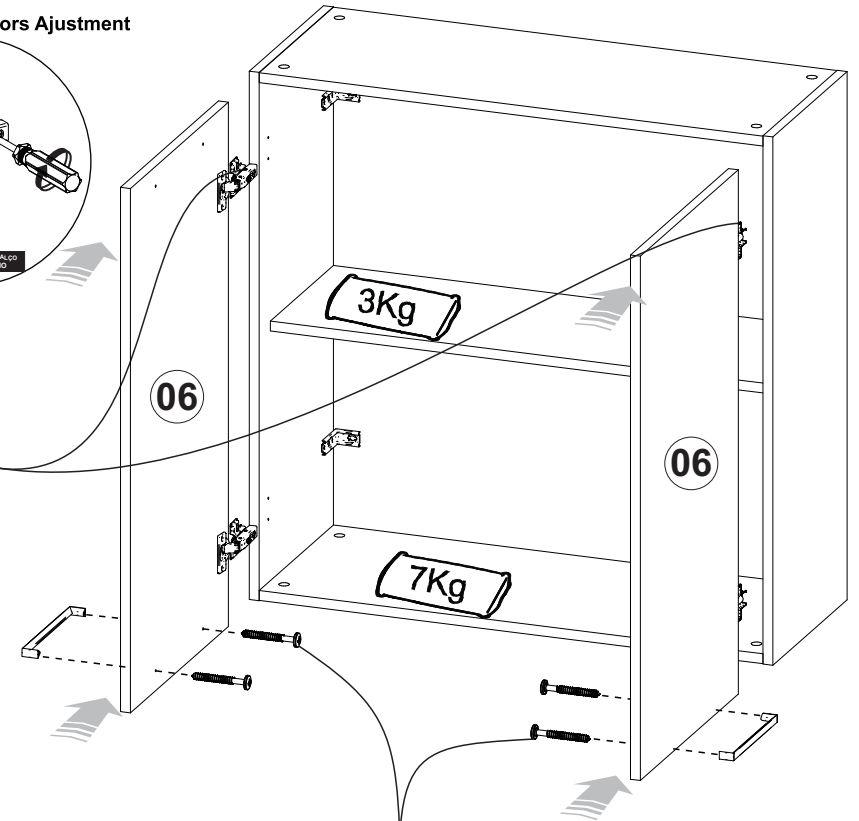
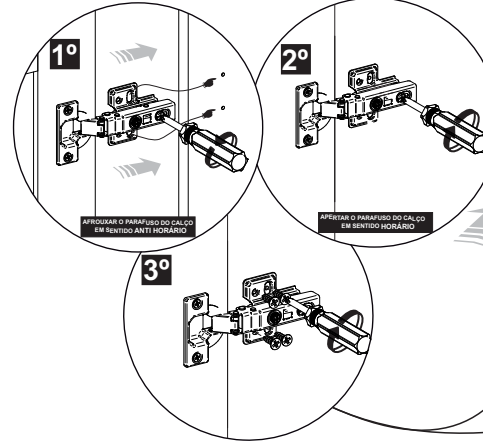

8

