

**Linea** Brasil

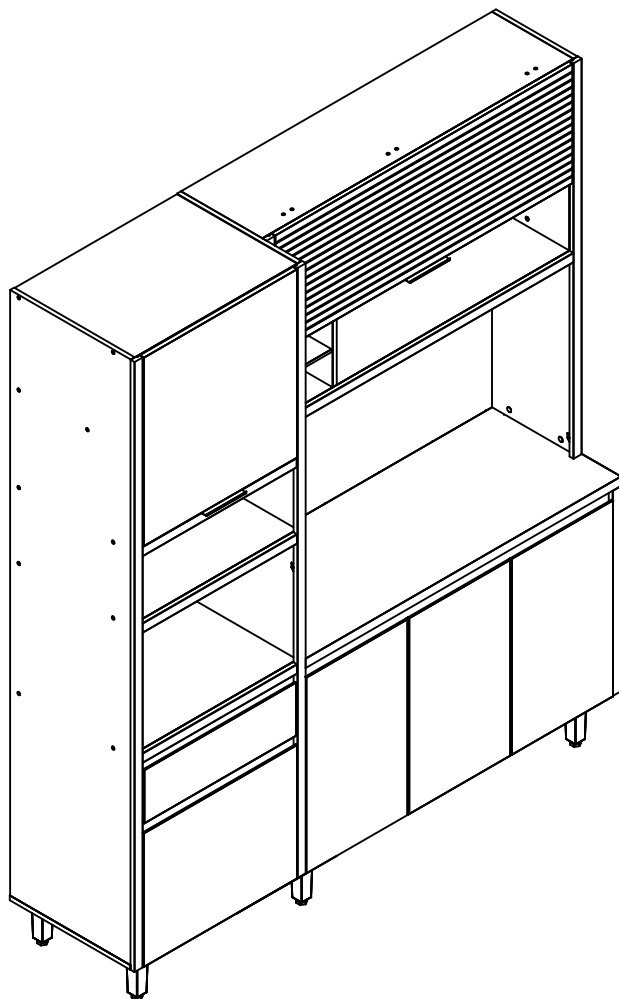

**KIT MONET**

V-3 05/04/24

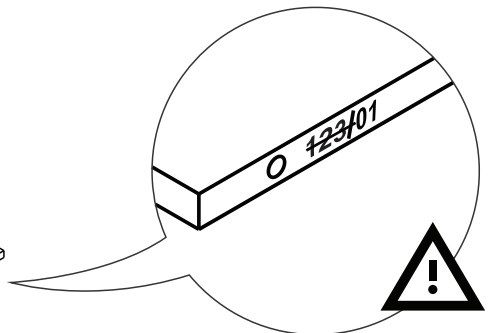
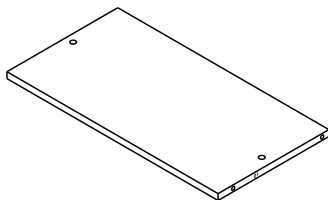
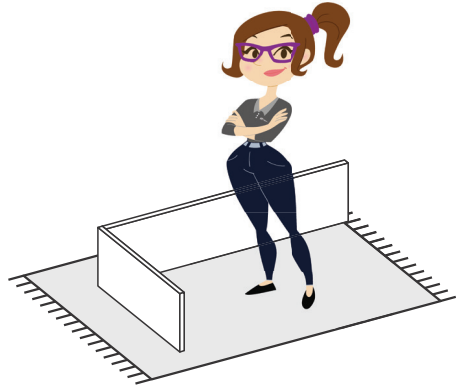
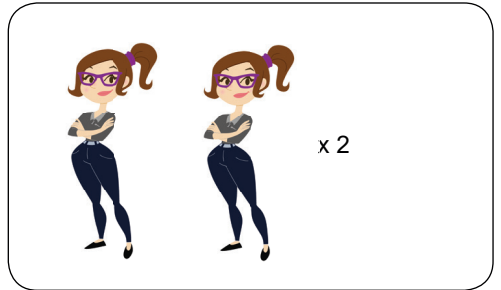
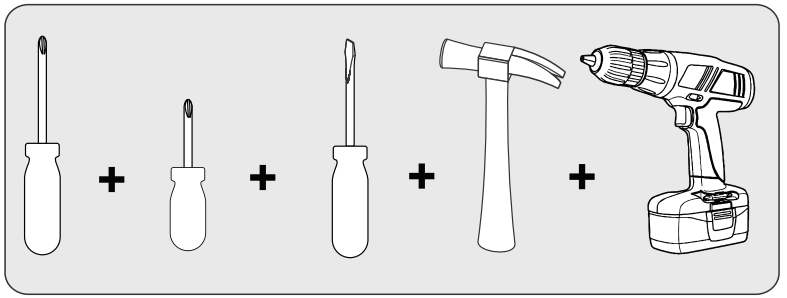
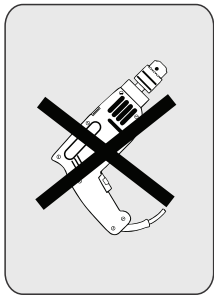

## GARANTIA / GARANTIA / WARRANTY

Nossos produtos são garantidos por 90 dias contra defeitos de fabricação. Ao constatar um problema coberto pela garantia, entre em contato com a loja onde o produto foi comprado. Ela estará capacitada para atendê-lo da melhor forma diante de cada caso. Reclamações de garantia somente poderão ser atendidas se o termo de garantia for apresentado no ato de reivindicação, acompanhado de sua nota fiscal de compra.

*Nuestros productos están garantidos contra defectos de fabricación por 90 días, a partir de la compra. Ao constatar un problema protegido por la garantía, póngase en contacto con la tienda donde se adquirió el producto. Ella estará capacitada para atenderlo de la mejor manera de acuerdo con cada caso.*

*Our products are guaranteed against manufacturing defects for 90 days from the date of purchase. When you find a problem covered by the warranty, please contact the store where the product was purchased. The store be able to serve you in the best way in each case.*

### Exclusões

- Desgaste natural ou danos causados por água, maresia, ferrugem, incêndio, calor, cupins e pragas em geral.
- Montagem, manutenção e uso inadequado.
- Não cumprimento das recomendações técnicas do esquema.
- Montagens e desmontagens após a primeira instalação.
- Instalações elétricas e outras afins.

### Exclusiones

- Desgaste natural o daños causados por agua, mares, maresia, incendios, calor, termitas y plagas en general.
- Montaje, mantenimiento y uso inadecuado.
- No cumplimiento de las recomendaciones técnicas del esquema.

### Exclusions

- Natural wear or damage caused by water, sea, rust, fire, heat, termites and plagues in general.
- Assembly, maintenance and improper use.
- Failure to comply with the technical recommendations of the assembly instructions.

### Importante

A Linha Brasil não autoriza nenhuma pessoa, loja ou entidade assumir em seu nome qualquer outra garantia que não conste no certificado. O fabricante reserva-se no direito de efetuar nos produtos eventuais modificações que considerar necessárias, sem prejudicar as características essenciais. Os produtos terão peças de assistência para reposição no período de 1 ano a contar de sua retirada do mercado, desde que haja matéria-prima equivalente, observando o dispositivo no Art.32 da Lei 8.078/90 (Cód. Defesa do Consumidor). O atendimento para produtos fora de linha é feito por programação especial, através da loja revendedora sob aprovação de consulta prévia ao fabricante.

### Importante

*Linea Brasil no autoriza a ninguna persona, tienda o entidad a asumir en su nombre cualquier otra garantía que no figure en el certificado. El fabricante se reserva el derecho de efectuar en los productos eventuales modificaciones que considere necesarias, sin perjudicar las características esenciales. Los productos tendrán piezas de asistencia para reposición en el período de 1 año a partir de su retirada del mercado. La atención para productos fuera de línea es hecha por programación especial, a través de la tienda revendedora bajo aprobación de consulta previa al fabricante.*

### Important

*Linea Brasil does not authorize any person, store or entity to assume on its behalf any other warranty that does not appear on the certificate. The manufacturer reserves the right to make in the products any modifications that it considers necessary without prejudice to the essential characteristics. The products will have replacement parts within one year of being withdrawn from the market. The service for off-line products is done by special programming, through the store reseller under prior consultation with the manufacturer.*

## INSTRUÇÕES DE LIMPEZA E CONSERVAÇÃO

### INSTRUCCIONES PARA LA LIMPIEZA E CONSERVACION / CLEAN AND PRESERVATION INSTRUCTURE

Para retirar o pó, utilize um pano seco, espanador ou aspirador. Se necessário, para uma limpeza mais efetiva, utilize um pano levemente umedecido com água. Finalize com uma flanela limpa e seca.

*Para eliminar el polvo, utilice un paño seco, mopa o la aspiradora. Si es necesario, para una limpieza más eficaz, utilice un paño ligeramente humedecido con agua. Terminar con un paño limpio y seco.*

*To take dirty, use a dry cloth, duster or vacuum. If necessary to take the dust, use a wet cloth. Finish with a clean and dry flannel.*

### IMPORTANTE / IMPORTANTE / IMPORTANT

- ⊗ Não utilize produtos abrasivos como álcool e detergentes, como também esponjas rígidas ou palha de aço na limpeza dos móveis. *No use limpiadores abrasivos como alcohol y detergentes, así como esponjas rígidas lana de acero para limpiar los muebles. Do not use abrasives such as alcohol and detergent, tough soaker also steel wool to clean the furniture.*

Proteja a superfície do móvel de objetos que transmitam calor ou umidade. *Proteja la superficie del mueble de objetos que transmitan calor o humedad. Protect the surface of the furniture against objects that can pass heat and humidity.*

Evitar o contato de água e produto de limpeza com o rodapé do produto, pois poderá danificá-lo. *Evitar el contacto con agua y producto de limpieza con el rodapé del producto, pues podrá dañarlo. Avoid the contact of water and cleaning products with baseboard, cause it should damage your product.*

Procure sempre utilizar flanela limpa e seca para a limpeza. *Busque siempre utilizar flanela limpia y seca para la limpieza. Try always to use a clean and dry flannel to cleaning.*

Cuidado com objetos pontiagudos, eles podem arranhar a superfície das portas e tampo. *Cuidado con objetos afilados, ellos pueden rayar la superficie de las puertas e la tapa. Take care with sharp objects, they can scratch the door lid surface.*

## Imagem Ilustrativa/ Illustrative Image/ Imagen Ilustrativa

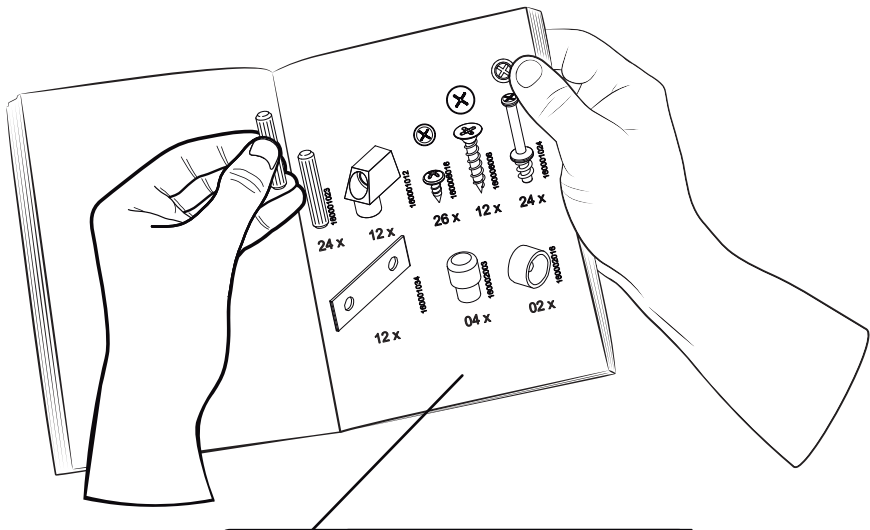

### Preste Atenção! ¡Preste atención! Attention!



As ferragens dos nossos manuais são sempre apresentadas nas mesmas proporções da peça na vida real.  
Caso apareça alguma dúvida no decorrer do processo de montagem, coloque a ferragem ao lado do desenho e faça a consulta :D

Los accesorios de nuestros manuales siempre se presentan en las mismas proporciones que la pieza en la vida real.  
Si tiene alguna duda durante el proceso de montaje, coloque los accesorios junto al dibujo y haga una consulta :D

The accessories in our manuals are always presented in the same proportions as the spare part in real life.  
If you have any questions during the assembly process, place the accessory next to the drawing and make an inquiry :D

### Símbolos: Símbolos: Symbols:



- + Parafuso Phillips
- Parafuso Fenda
- Parafuso Allen

- + Tomillo Phillips
- Tomillo Ranurado
- Tomillo Allen

- + Phillips screw
- Slotted Screw
- Allenscrew

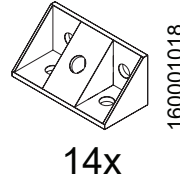
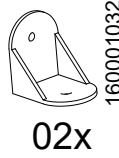
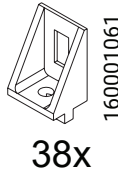
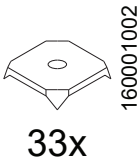
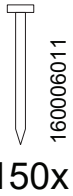
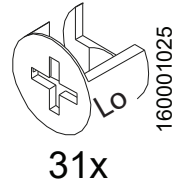
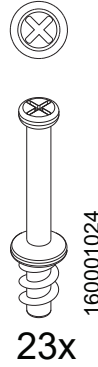
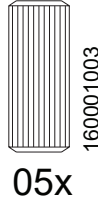
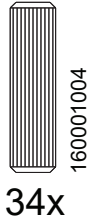
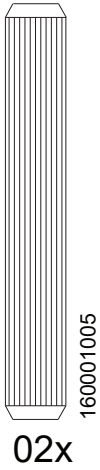

Lorem ipsum

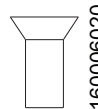
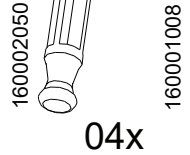
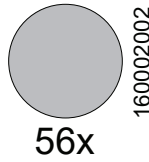
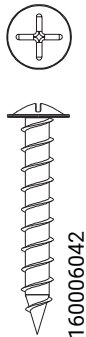

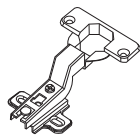

160003016

10x

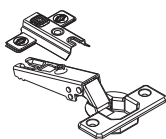

160003003

03x

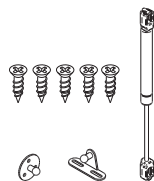

160003017

02x



160002012

02x



160009047

x08

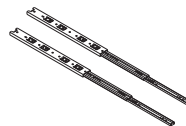

160008006

01x

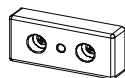

160002014

06x

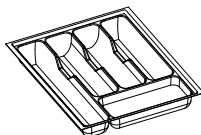

160009054

01x



160005071

02x



160002060

04x

1°

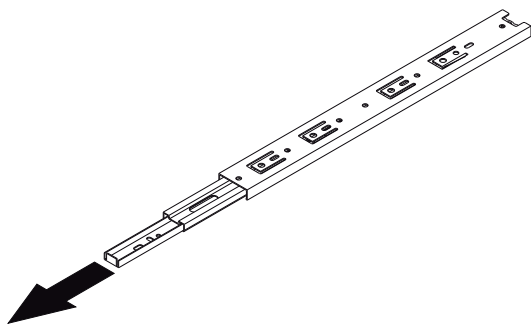

2°

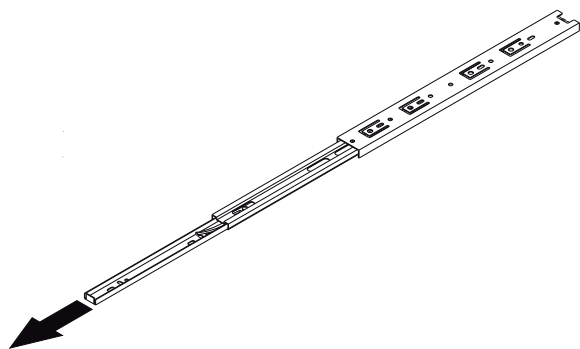

3°

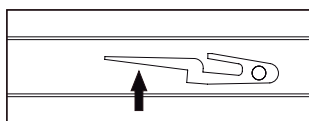
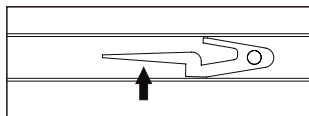
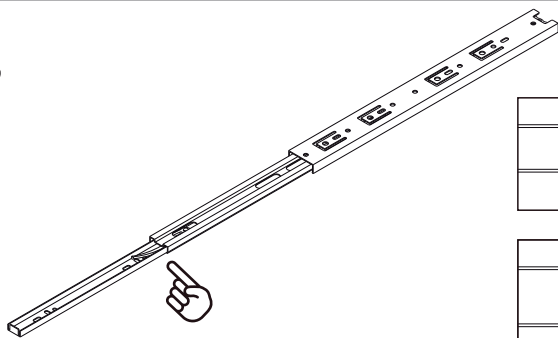

4°

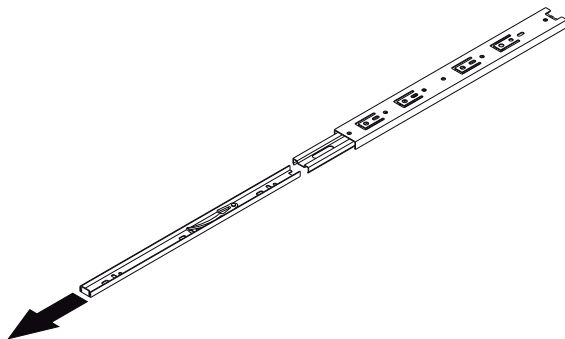

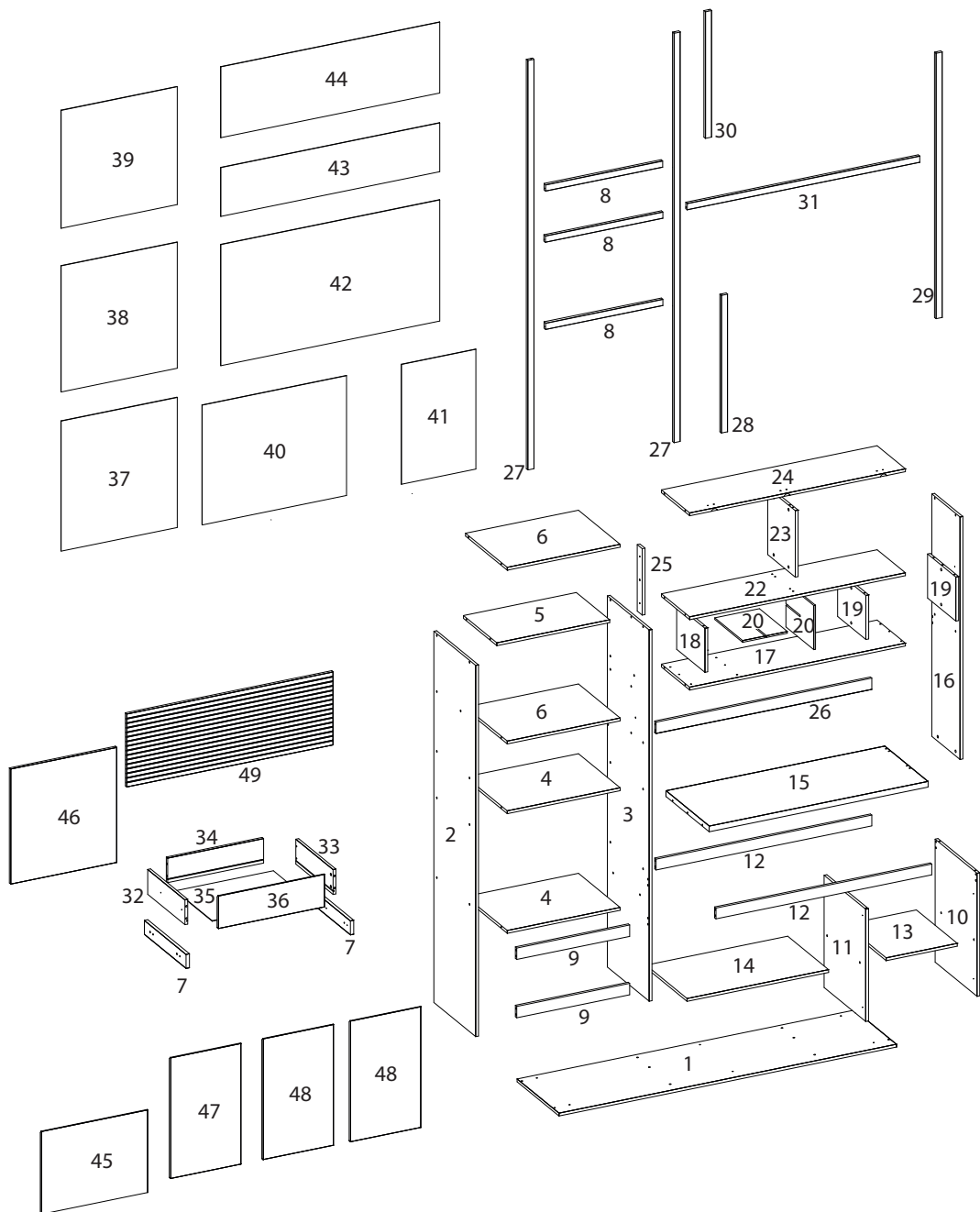



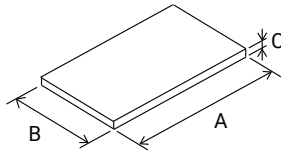

VOLUME Caja BOX	ITEM Artículo Item	PEÇA Pieza Part	DESCRIÇÃO Descripción Description	DIMENSÕES (mm)			QUANTIDADE Cantidad Amount	Material
				Dimensión/Dimension				
				A	B	C		
2	1	510392001	BASE	1815	451	15	1	MDF
1	2	510392002	LATERAL ESQUERDA TORRE	1955	450	15	1	MDF
1	3	510392003	LATERAL DIREITA TORRE	1955	450	15	1	MDF
2	4	510392004	PRATELEIRA TORRE	607	449	15	2	MDF
3	5	510392005	PRATELEIRA MENOR TORRE	607	359	15	1	MDF
1	6	510392006	PRATELEIRA TORRE SUPERIOR	607	449	15	2	MDF
1	7	510392007	DISTANCIADOR DE GAVETA	448	74	18	2	MDF
3	8	510392008	ENCABECAMENTO PRATELEIRA TORRE	576	31	15	3	MDF
3	9	510392009	VISTA TORRE	607	60	15	2	MDF
1	10	510392010	LATERAL DIREITA BALCAO	648	450	15	1	MDF
2	11	510392011	DIVISAO BALCAO	591	449	15	1	MDF
2	12	510392012	VISTA BALCAO	1160	57	15	2	MDF
2	13	510392013	PRATELEIRA MENOR BALCAO	440	382	15	1	MDF
1	14	510392014	PRATELEIRA MAIOR BALCAO	761	440	15	1	MDF
2	15	510392015	TAMPO	1177	465	30	1	MDF
2	16	510392016	LATERAL DIREITA SUPERIOR BALCAO	1277	304	15	1	MDF
3	17	510392017	BASE ADEGA	1160	304	15	1	MDF
3	18	510392018	LATERAL ESQUERDA ADEGA	304	232	15	1	MDF
1	19	510392019	LATERAL DIREITA NICHOS	304	232	15	2	MDF
1	20	510392020	DIVISAO ADEGA	300	232	9	2	MDF
3	22	510392022	BASE DO AEREO	1160	304	15	1	MDF
3	23	510392023	DIVISAO AEREO	350	297	15	1	MDF
3	24	510392024	TAMPO DO AEREO	1160	304	15	1	MDF
1	25	510392025	APOIO ESQUERDO AEREO	350	54	15	1	MDF
2	26	510392026	APOIO DO AEREO	1160	60	15	1	MDF
1	27	510392027	ENCABECAMENTO TORRE	1970	31	15	2	MDF
1	28	510392028	ENCABECAMENTO BALCAO	662	31	15	1	MDF
2	29	510392029	ENCABECAMENTO LATERAL DIREITO AEREO	1277	31	15	1	MDF
3	30	510392030	ENCABECAMENTO LATERAL ESQUERDO AEREO	613	31	15	1	MDF
1	31	510392031	ENCABECAMENTO PRATELEIRA AEREO	1142	31	15	1	MDF
1	32	510392032	LATERAL ESQUERDA GAVETA	400	124	15	1	MDF
1	33	510392033	LATERAL DIREITA GAVETA	400	124	15	1	MDF
3	34	510392034	CONTRA FUNDO GAVETA	516	123	15	1	MDF
1	35	510392035	FUNDO GAVETA	526	394	2,8	1	MDF
3	36	510392036	FRENTE GAVETA	570	171	15	1	MDF
1	37	510392037	FUNDO INFERIOR TORRE	685	626	2,8	1	MDF
1	38	510392038	FUNDO CENTRAL TORRE	666	626	2,8	1	MDF
1	39	510392039	FUNDO SUPERIOR TORRE	618	626	2,8	1	MDF
1	40	510392040	FUNDO ESQUERDO BALCAO	776	631	2,8	1	MDF
1	41	510392041	FUNDO DIREITO BALCAO	631	400	2,8	1	MDF
1	42	510392042	FUNDO CENTRAL	1177	640	2,8	1	MDF
1	43	510392043	FUNDO ADEGA	1177	257	2,8	1	MDF
1	44	510392044	FUNDO DO AEREO SUPERIOR	1177	373	2,8	1	MDF
3	45	510392045	PORTA INFERIOR TORRE	570	435	15	1	MDF
3	46	510392046	PORTA SUPERIOR TORRE	609	570	15	1	MDF
3	47	510392047	PORTA ESQUERDA BALCAO	634	378	15	1	MDF
3	48	510392048	PORTA DIREITA BALCAO	634	378	15	2	MDF
2	49	510392049	PORTA DO AEREO	1109	385	15	1	MDF

ITEM	DESCRIPTION	ARTÍCULO	DESCRIPCIÓN
1	BASIS	1	BASE
2	LEFT SIDE TOWER	2	TORRE DEL LADO IZQUIERDO
3	RIGHT SIDE TOWER	3	TORRE DEL LADO DERECHO
4	TOWER SHELF	4	ESTANTE DE LA TORRE
5	SMALLER SHELF TOWER	5	TORRE DE ESTANTE MÁS PEQUEÑA
6	TOP TOWER SHELF	6	ESTANTE SUPERIOR DE LA TORRE
7	DRAWER DISTANCER	7	DISTANCIADOR DE CAJONES
8	TOWER SHELF HEADING	8	ENCABEZADO DEL ESTANTE DE LA TORRE
9	TOWER VIEW	9	VISTA DE LA TORRE
10	RIGHT SIDE COUNTER	10	MOSTRADOR DEL LADO DERECHO
11	COUNTER DIVISION	11	DIVISIÓN DE CONTADOR
12	BALCAO VIEW	12	VISTA AL BALCAO
13	SMALLER COUNTER SHELF	13	ESTANTE DE MOSTRADOR MÁS PEQUEÑO
14	BIGGER COUNTER SHELF	14	ESTANTE DE MOSTRADOR MÁS GRANDE
15	COVER	15	CUBRIR
16	TOP RIGHT SIDE COUNTER	16	MOSTRADOR DEL LADO SUPERIOR DERECHO
17	WINERY BASE	17	BODEGA BASE
18	LEFT SIDE WINERY	18	BODEGA LADO IZQUIERDO
19	NICHE RIGHT SIDE	19	NICHO LADO DERECHO
20	HORIZONTAL DIVISION WINERY	20	BODEGA DIVISIÓN HORIZONTAL
21	VERTICAL DIVISION WINERY	21	BODEGA DIVISIÓN VERTICAL
22	AIR BASE	22	BASE AEREA
23	AIR DIVISION	23	DIVISIÓN AÉREA
24	AERIAL TOP	24	AIRE SUPERIOR
25	LEFT AIR SUPPORT	25	APOYO AÉREO IZQUIERDO
26	AIRLINE SUPPORT	26	SOPORTE AÉREO
27	TOWER HEADING	27	RUMBO DE LA TORRE
28	COUNTER HEADING	28	CONTRATÍTULO
29	AIR RIGHT SIDE HEADING	29	RUMBO DEL LADO DERECHO DEL AIRE
30	AERIAL LEFT SIDE HEADING	30	RUMBO AÉREO LADO IZQUIERDO
31	AERIAL RACK HEADING	31	RUMBO DEL ESTANTE AÉREO
32	LEFT SIDE DRAWER	32	CAJÓN DEL LADO IZQUIERDO
33	RIGHT SIDE DRAWER	33	CAJÓN DEL LADO DERECHO
34	DRAWER BACKGROUND	34	FONDO DEL CAJÓN
35	DRAWER BOTTOM	35	FONDO DEL CAJÓN
36	DRAWER FRONT	36	FRENTE DEL CAJÓN
37	LOWER TOWER BOTTOM	37	FONDO DE LA TORRE INFERIOR
38	CENTRAL TOWER BACKGROUND	38	FONDO DE LA TORRE CENTRAL
39	TOP TOWER BOTTOM	39	TORRE SUPERIOR ABAJO
40	BACKGROUND BALCAO	40	ANTECEDENTES BALCAO
41	RIGHT BALCAO FUND	41	FONDO DERECHO BALCAO
42	CENTRAL FUND	42	FONDO CENTRAL
43	WINERY FUND	43	FONDO DE BODEGA
44	TOP AERIAL BOTTOM	44	ARRIBA ANTENA ABAJO
45	LOWER DOOR TOWER	45	TORRE DE PUERTA INFERIOR
46	TOP TOWER DOOR	46	PUERTA SUPERIOR DE LA TORRE
47	LEFT DOOR COUNTER	47	MOSTRADOR DE PUERTA IZQUIERDA
48	RIGHT DOOR BALCAO	48	BALCAO PUERTA DERECHA
49	AIRLINE DOOR	49	PUERTA DE LA LÍNEA AÉREA

# 01

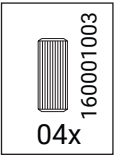
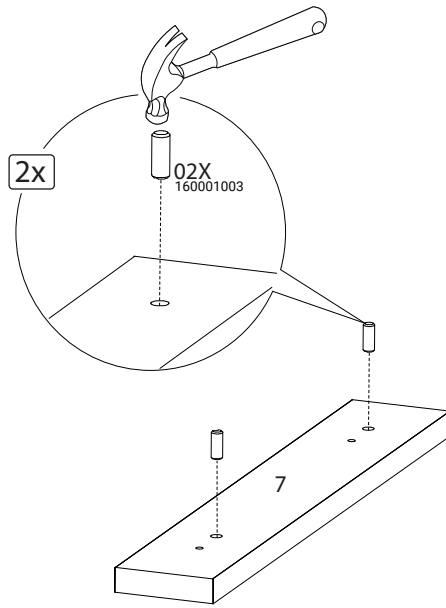

# 02

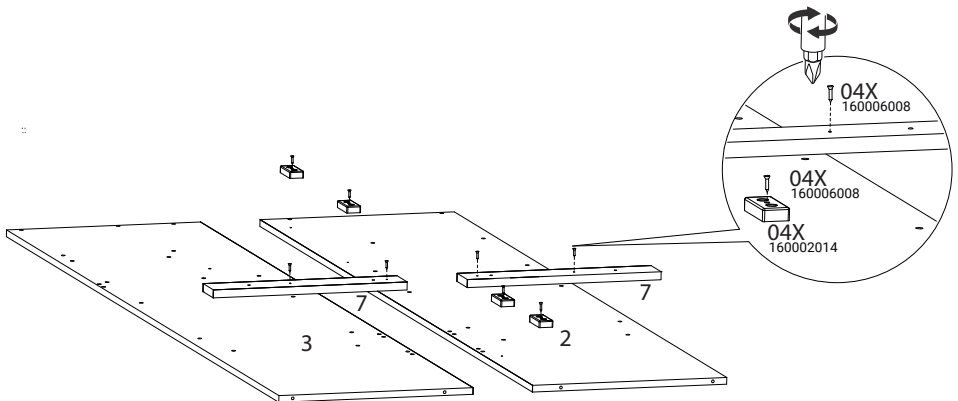
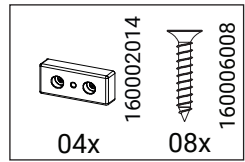

# 03

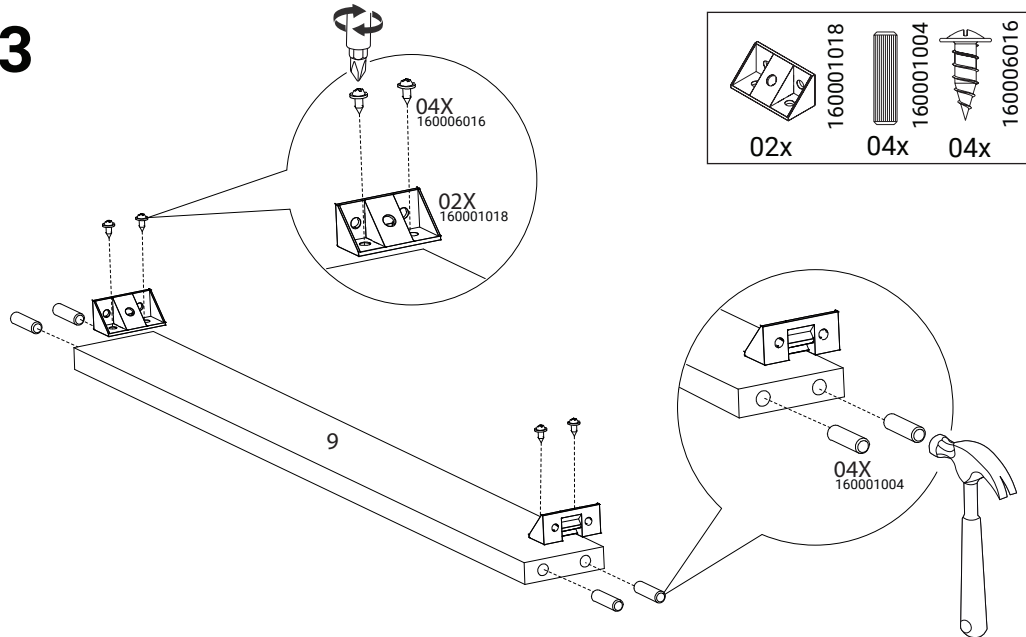

# 04

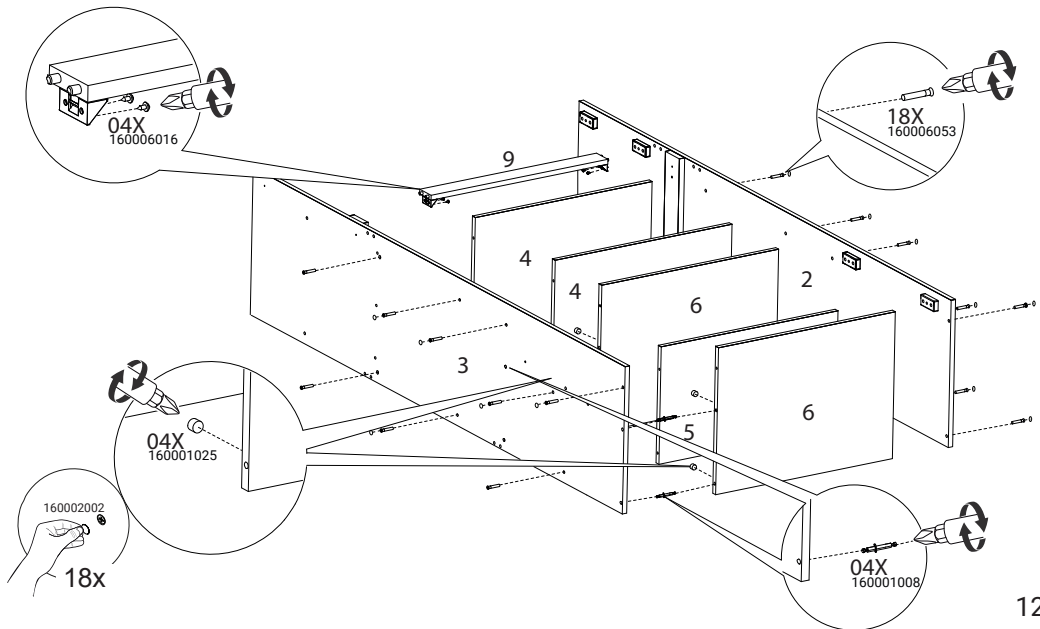
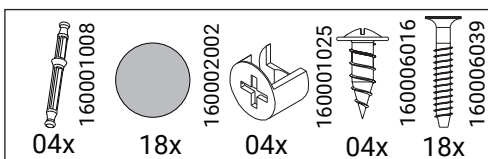
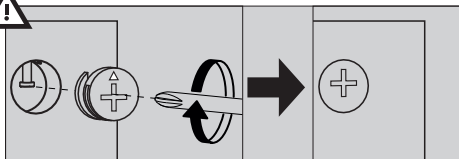

# 05

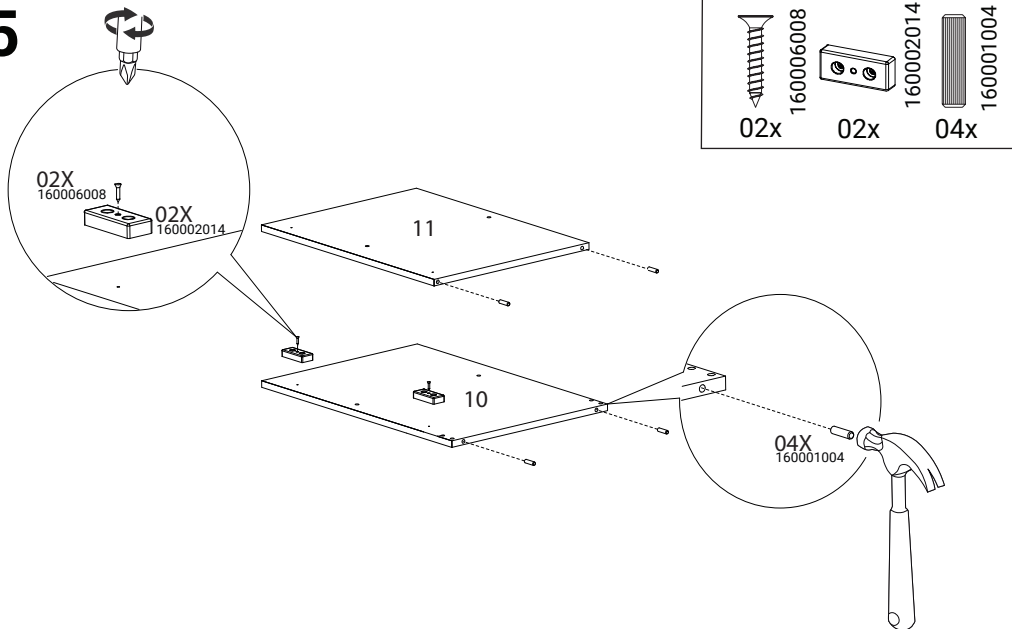

# 06

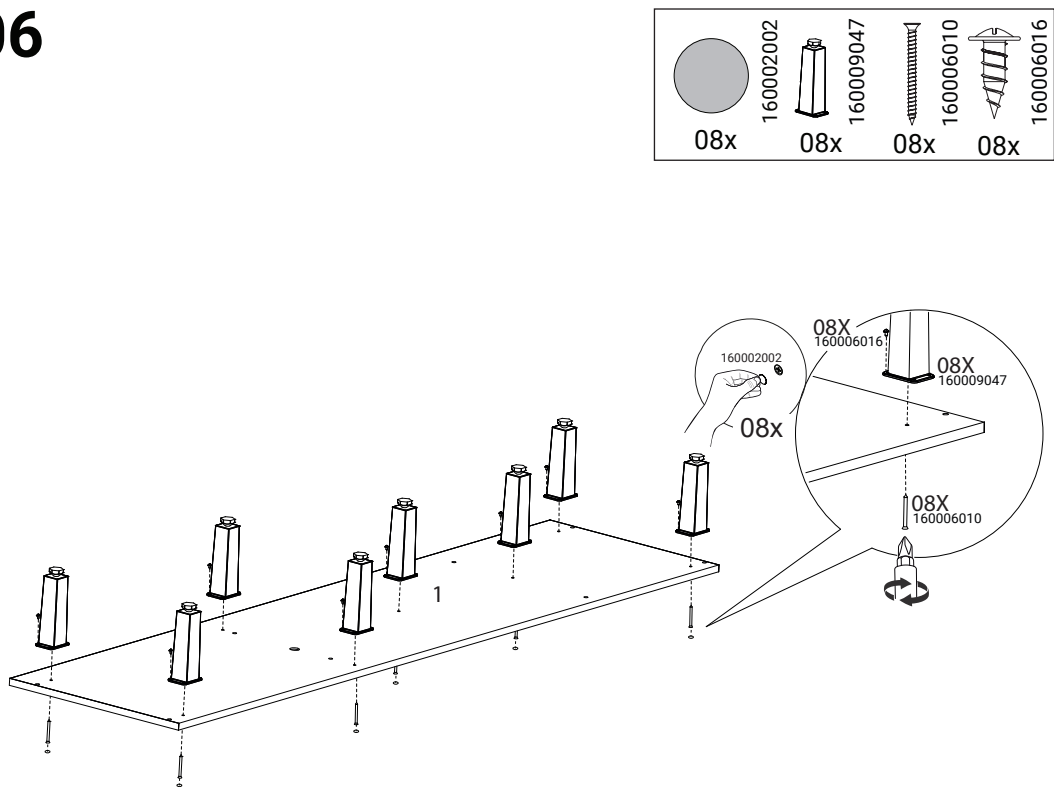

# 07

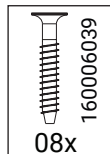
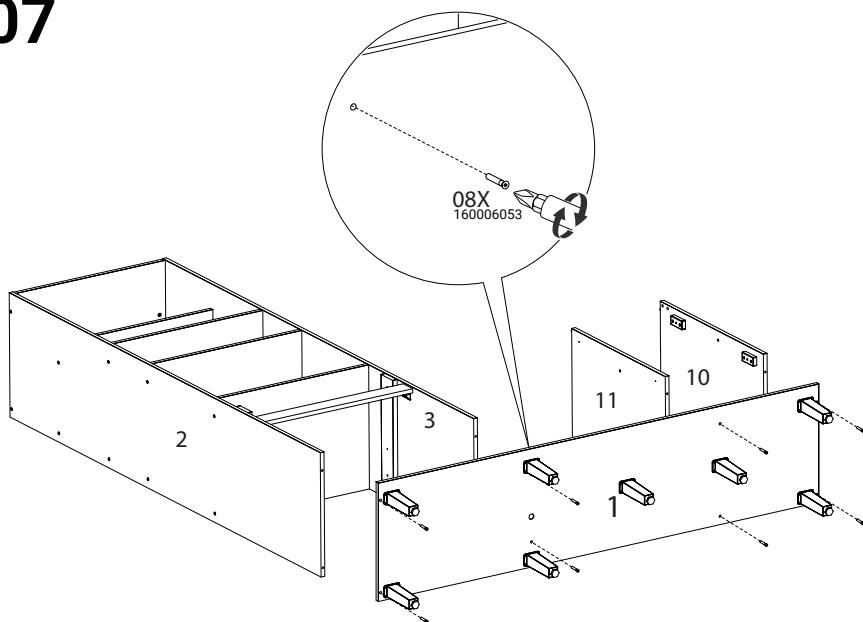

08X  
160006053

2

3

11

10

1

# 08

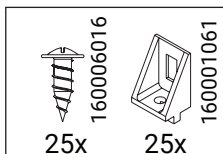
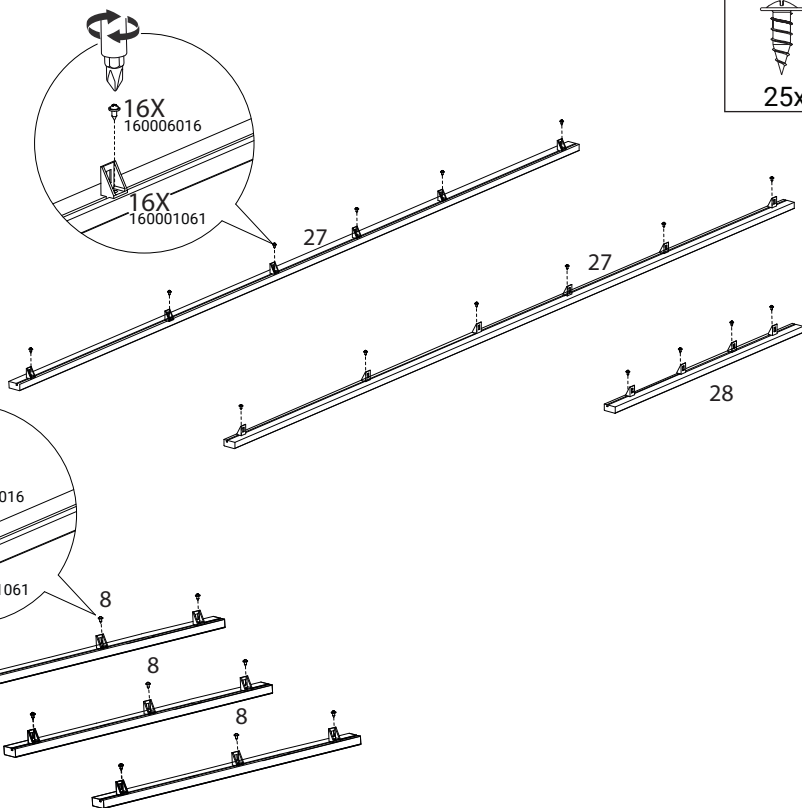

16X  
160006016

16X  
160001061

27

27

28

9X  
160006016

9X  
160001061

8

8

8

# 09



25x

160006016

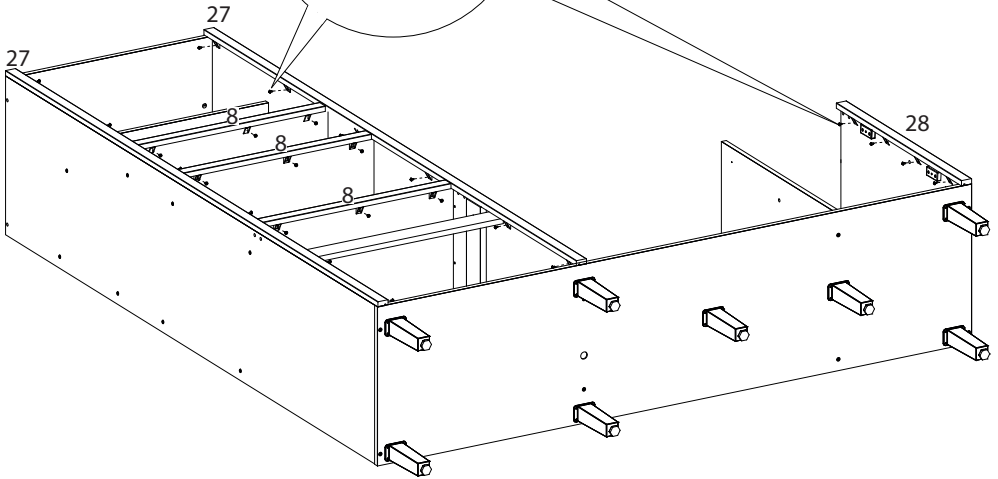
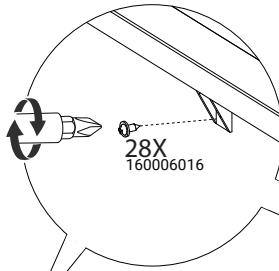

# 10

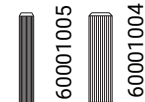

160001005

160001004

02x

06x

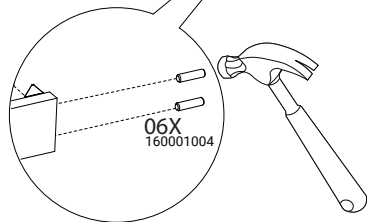
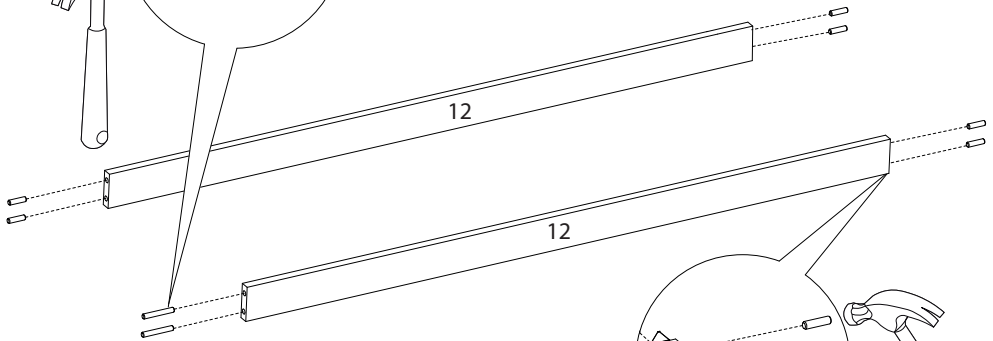
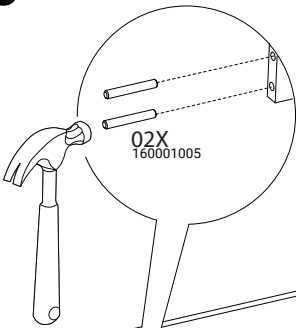

# 11

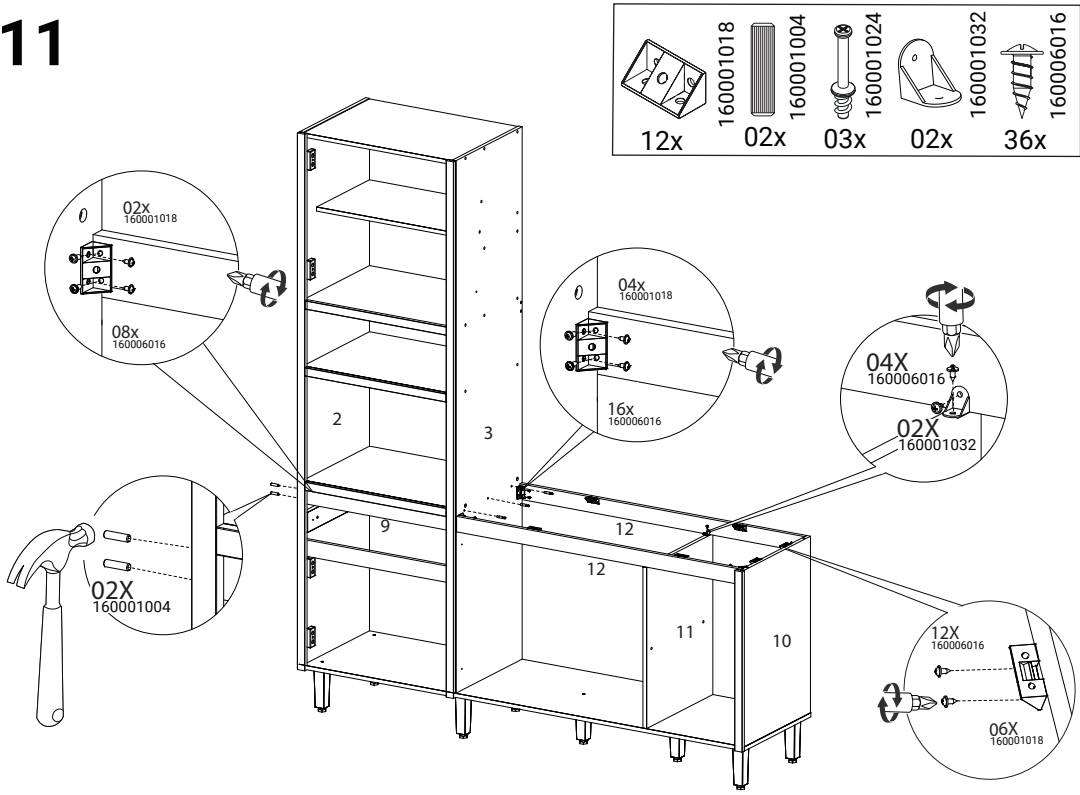

# 12

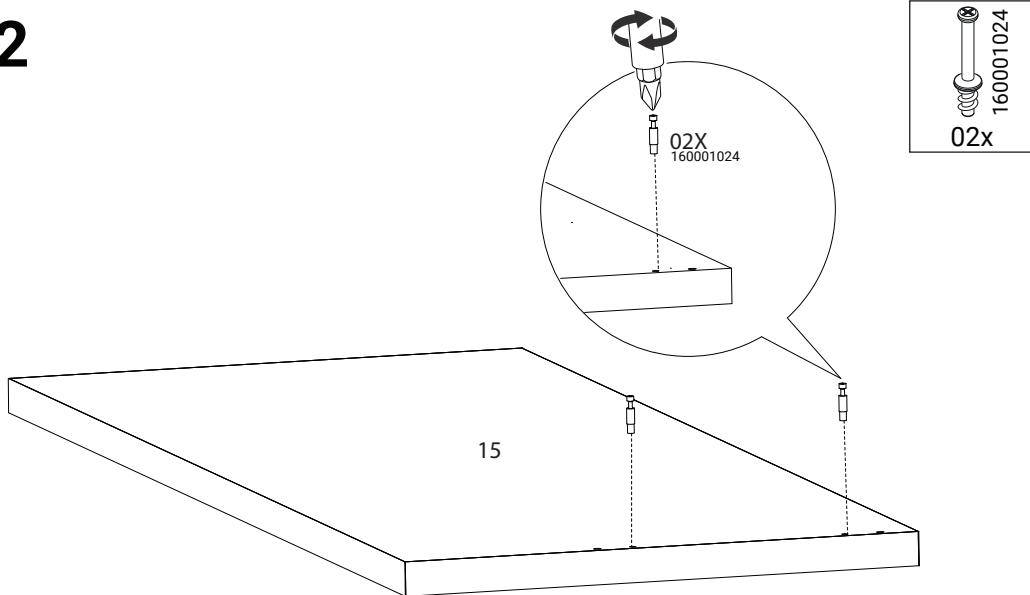



# 13

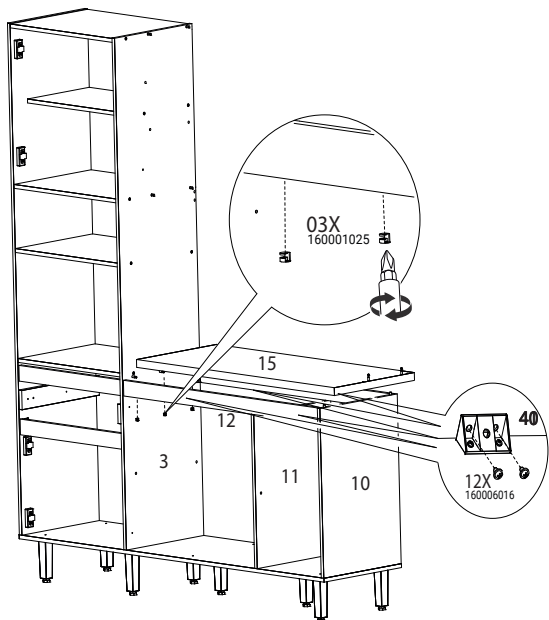
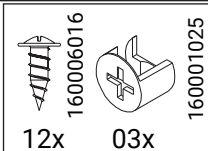

# 14

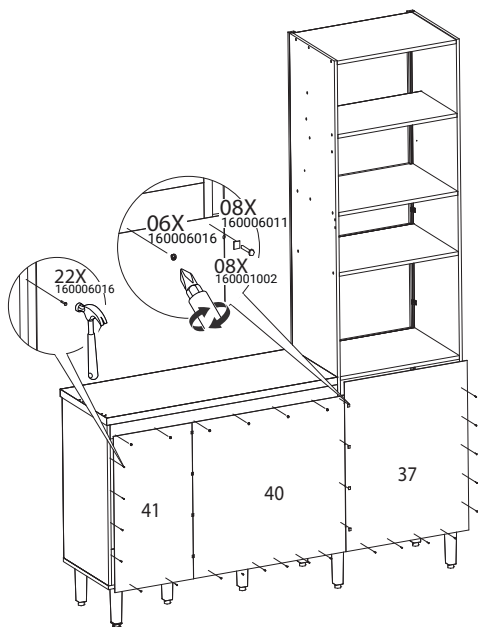
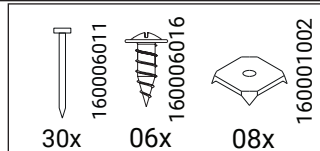

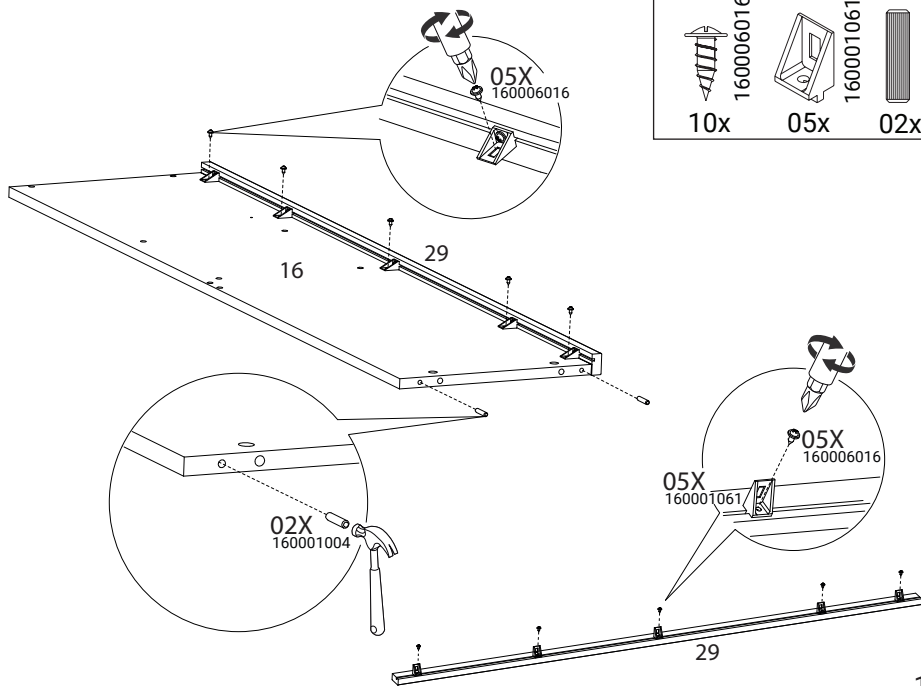
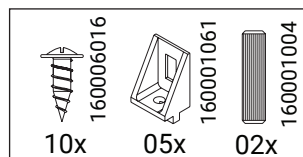

# 15

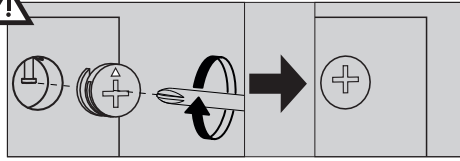

# 16



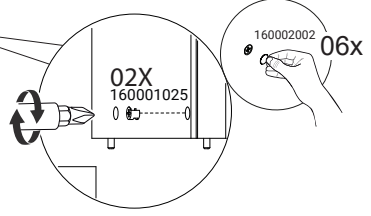
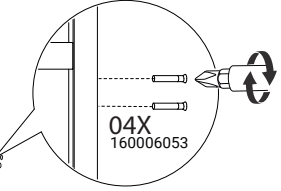
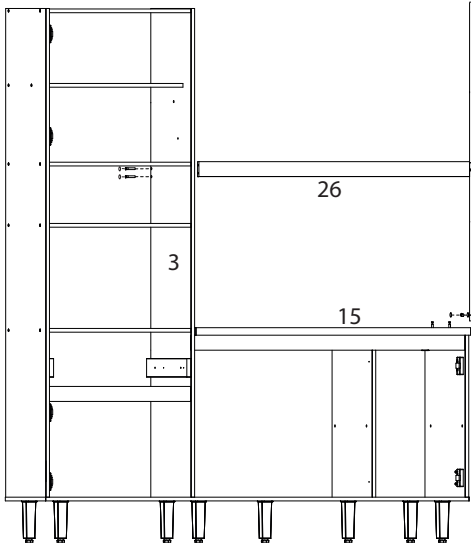

		
160002002	160001025	160006039
06x	02x	04x

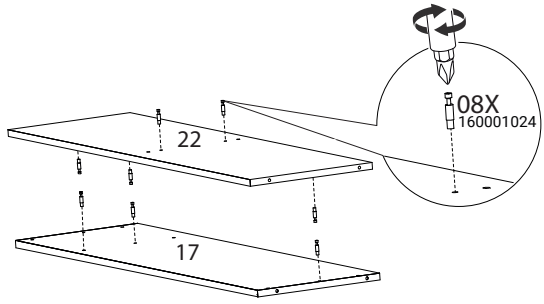

# 17



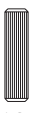

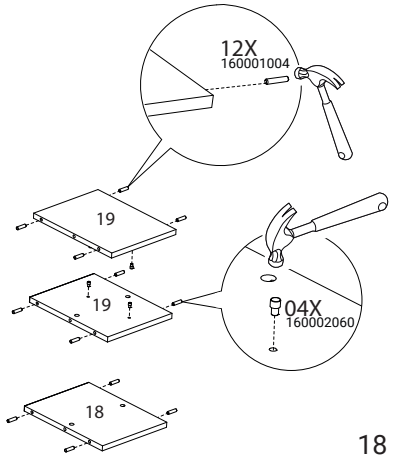
		
160002060	160001024	160001004
04x	08x	12x



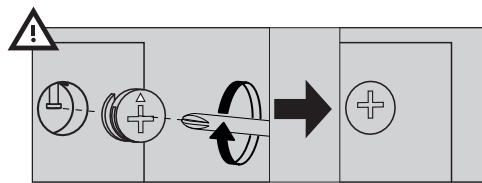

# 18

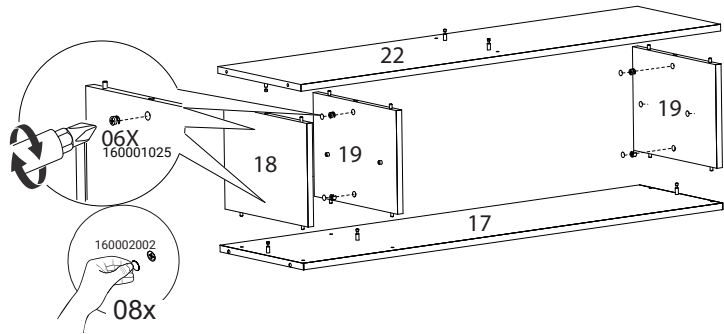

	160002002		160001025
08x		06x	

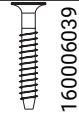

# 19

	160002002		160001025		160006039
08x		02x		06x	

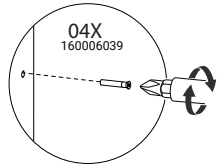
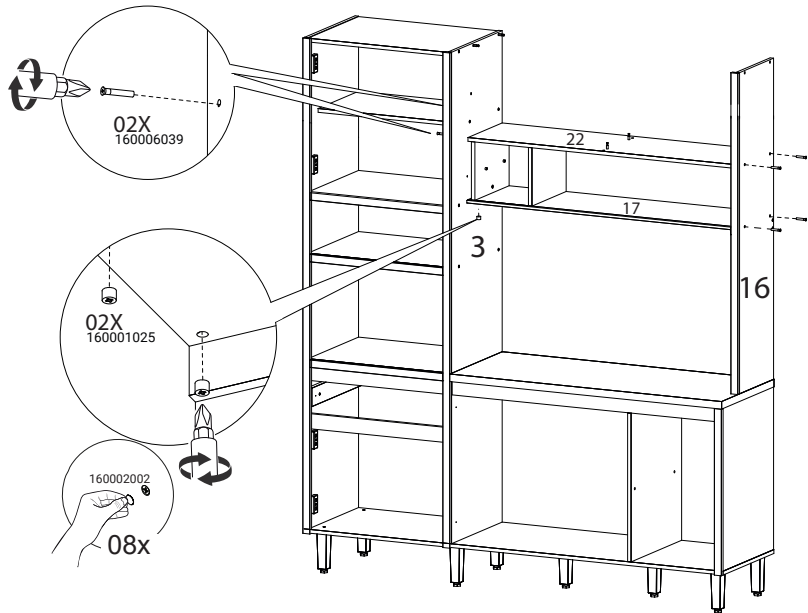

# 20

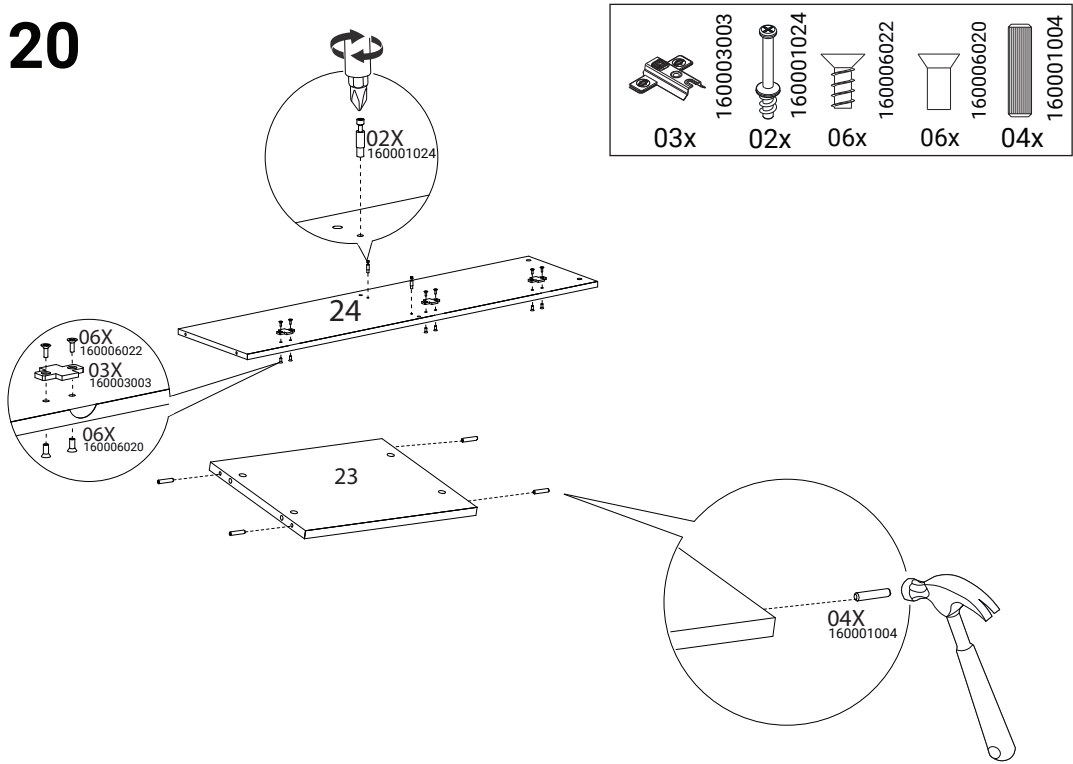

# 21

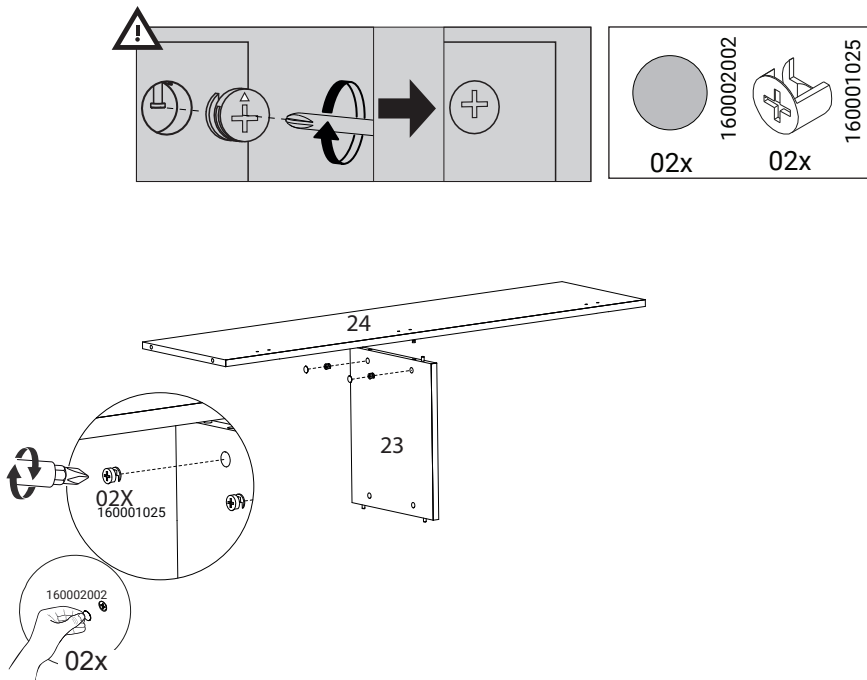

# 22

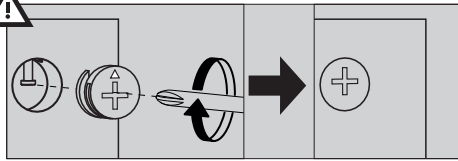

- 160002002 06x
- 160001025 04x
- 160006039 02x

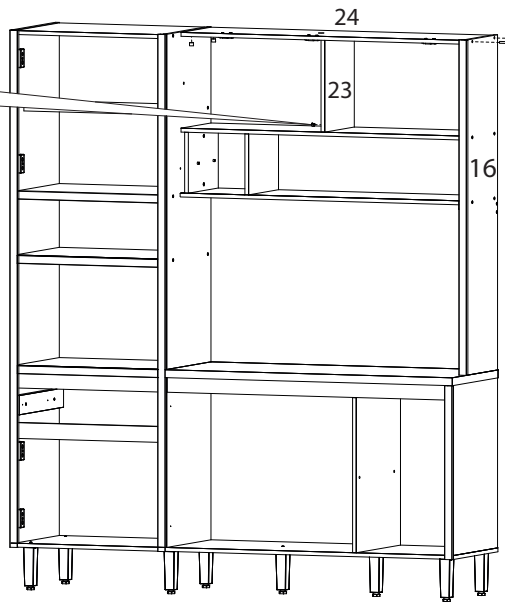
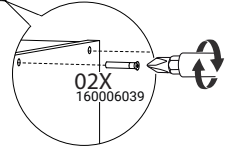
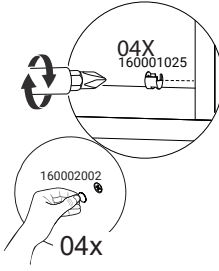

# 23

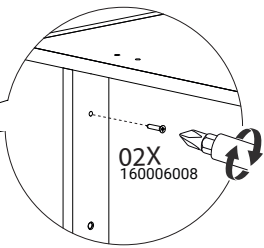
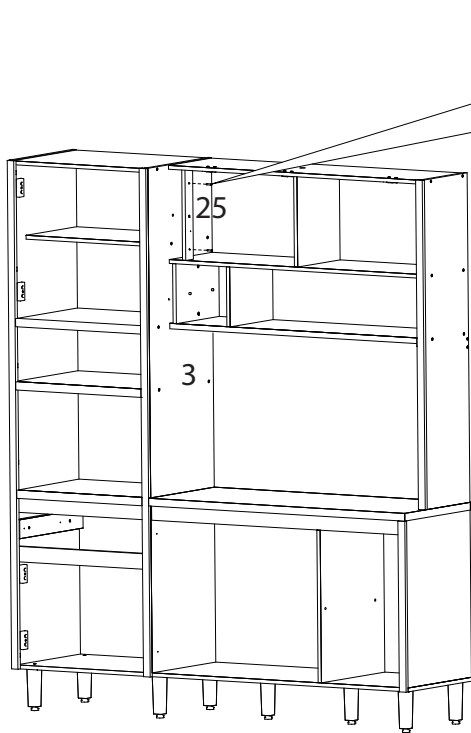

- 160006008 02x
- 160001003 01x

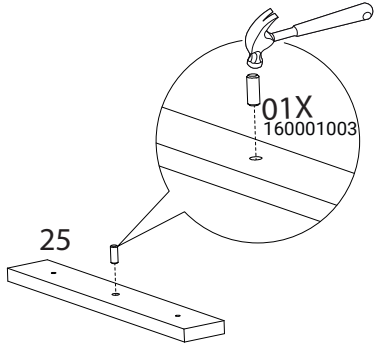

# 24

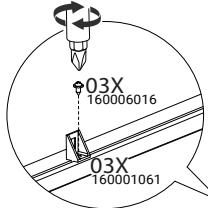
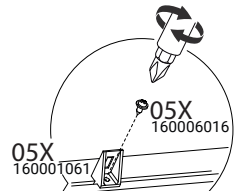
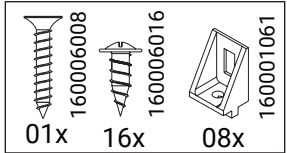
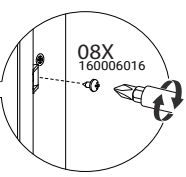
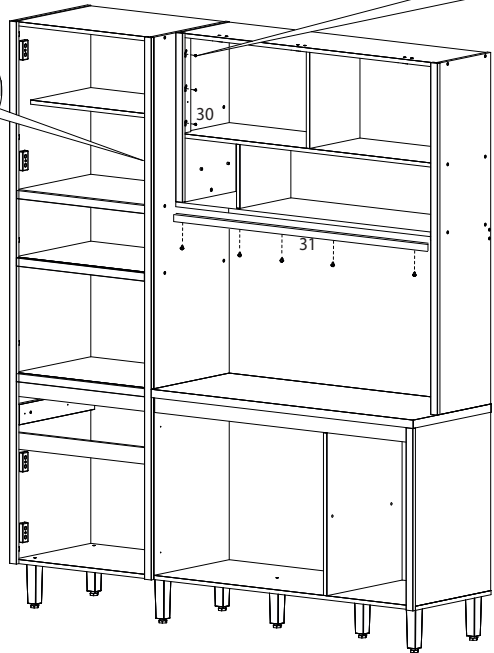

# 25

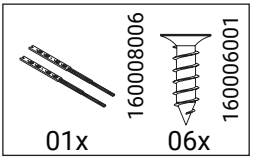
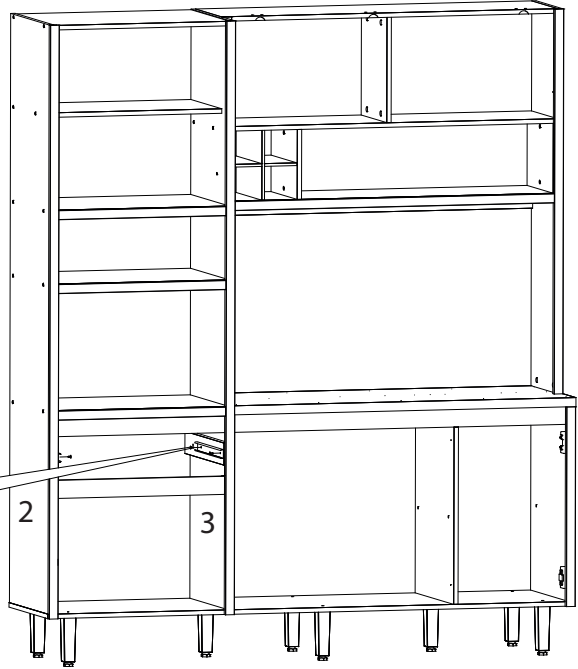
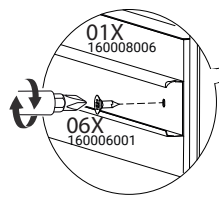



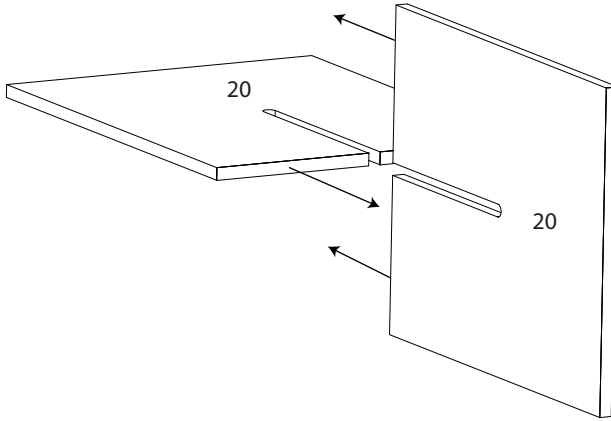

# 26

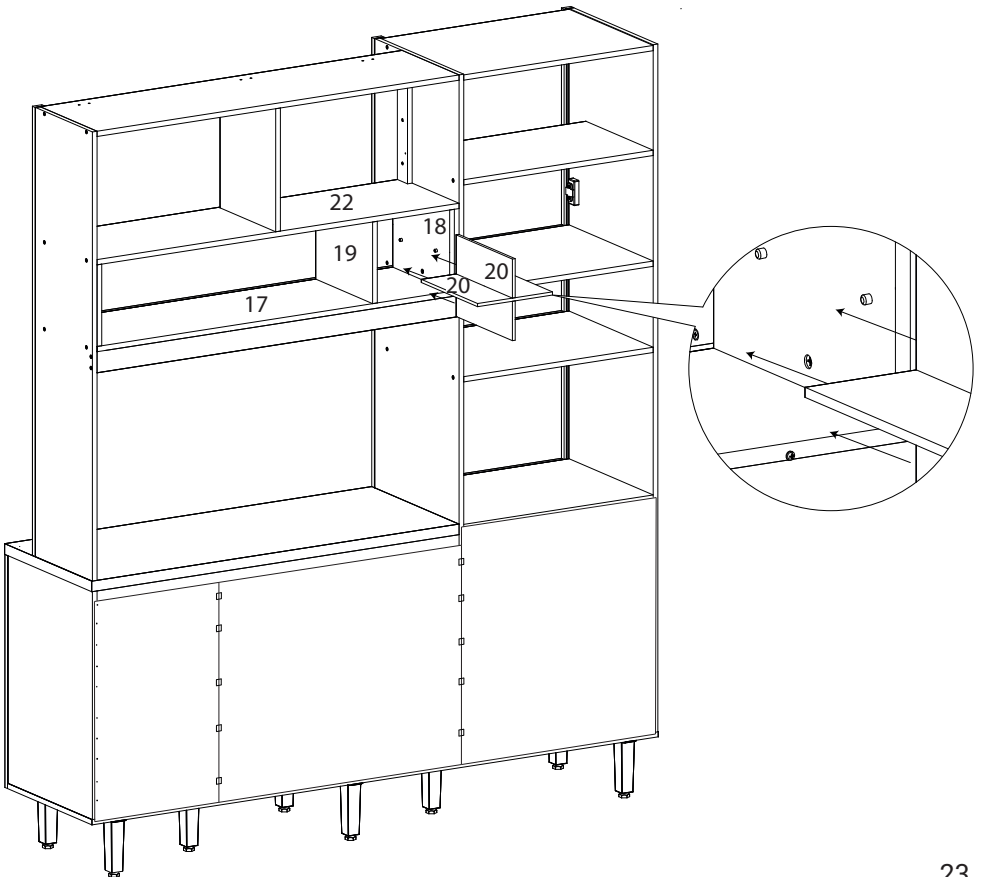

# 27



# 28

			
18x	135x	25x	160001002

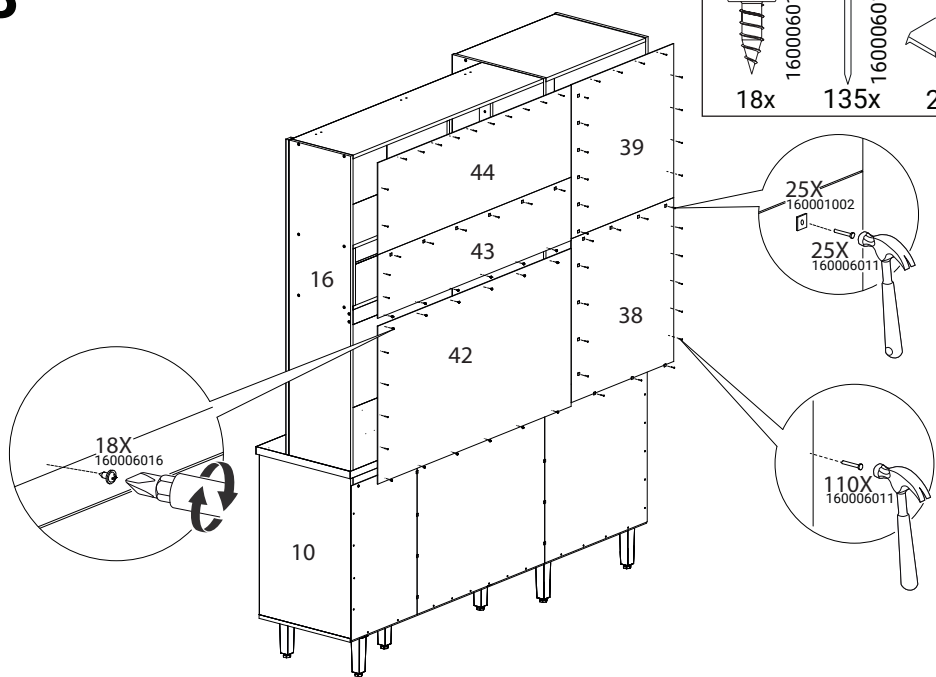

# 29

08x

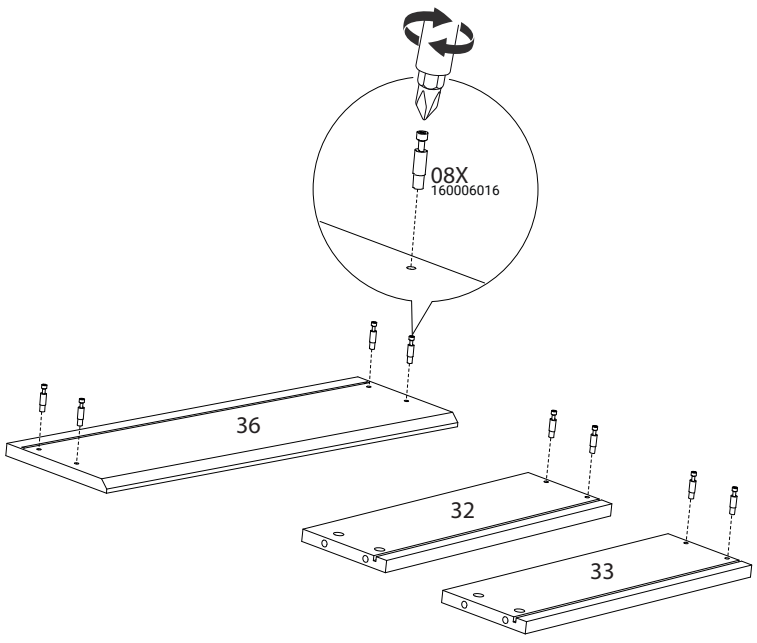



# 30

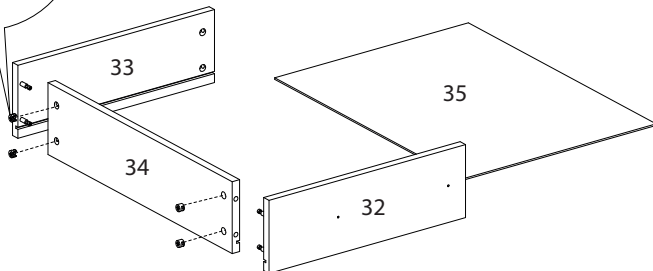
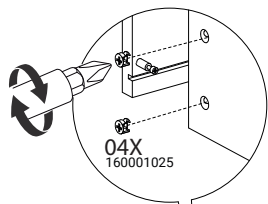
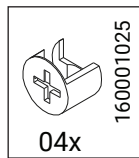
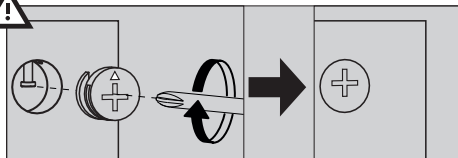

# 31

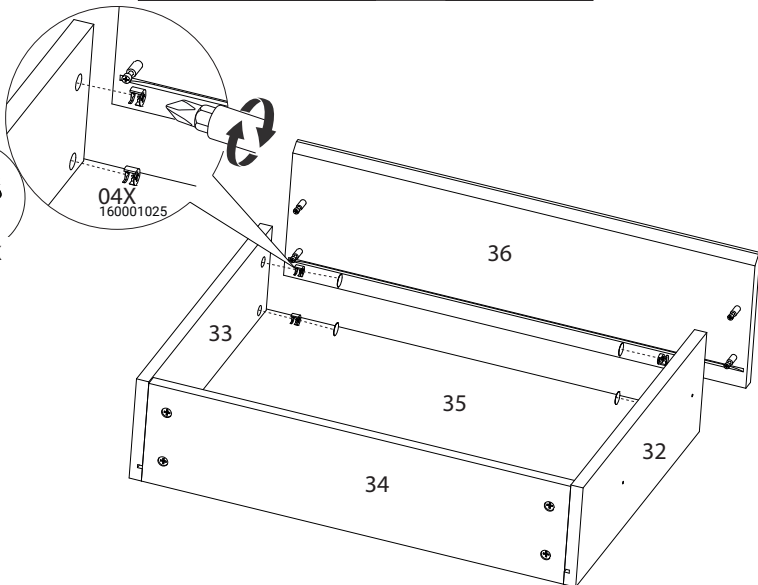
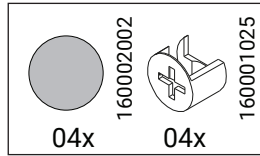
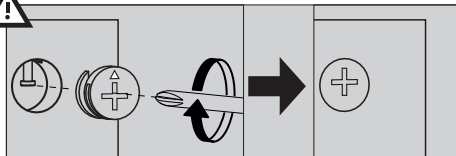

# 32

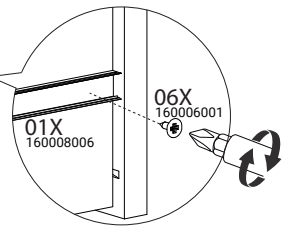
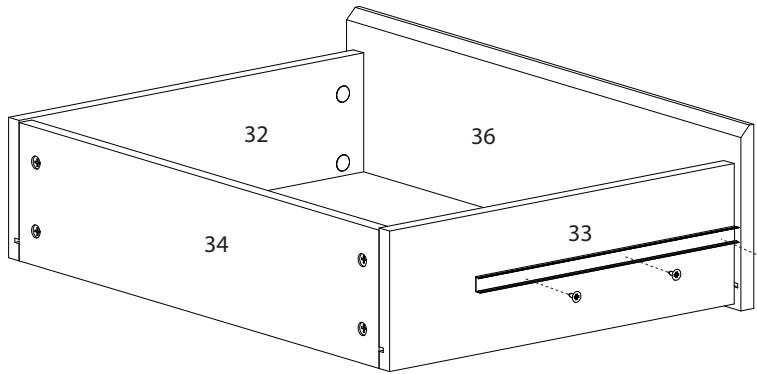
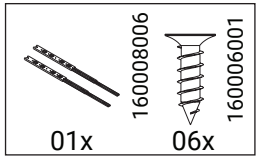

# 33

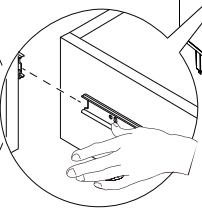
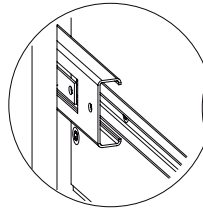
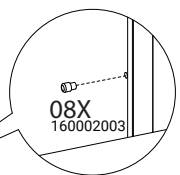
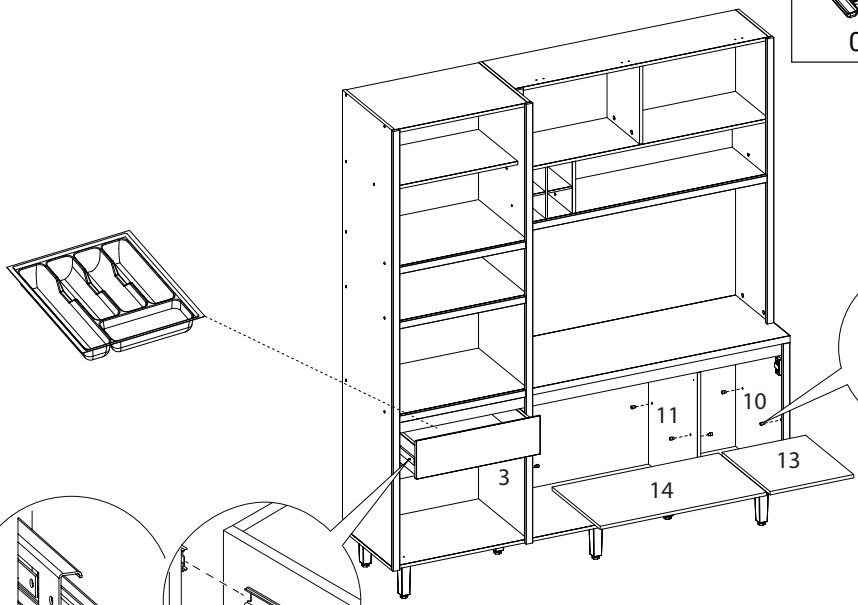
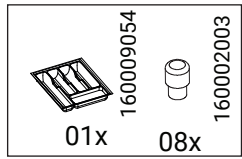

# 34

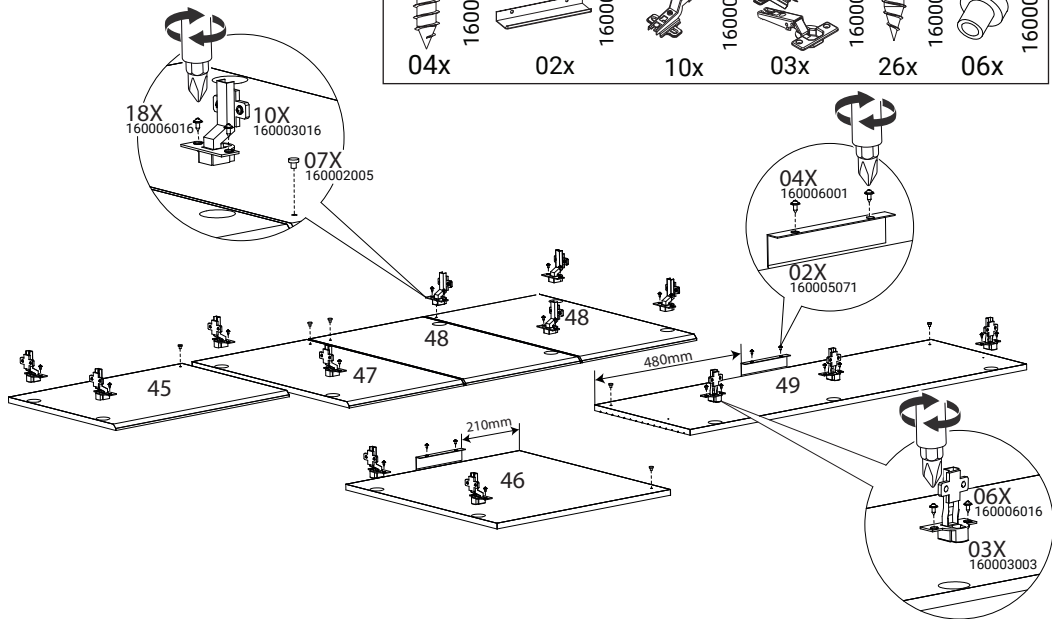
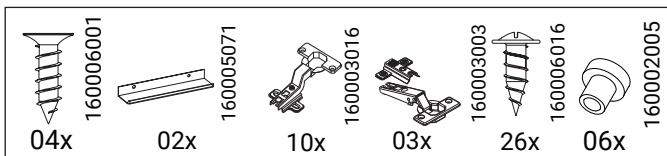

# 35

FURO DE MARCAÇÃO  
MARKING HOLE  
MARCAÇÃO DE AGUERO

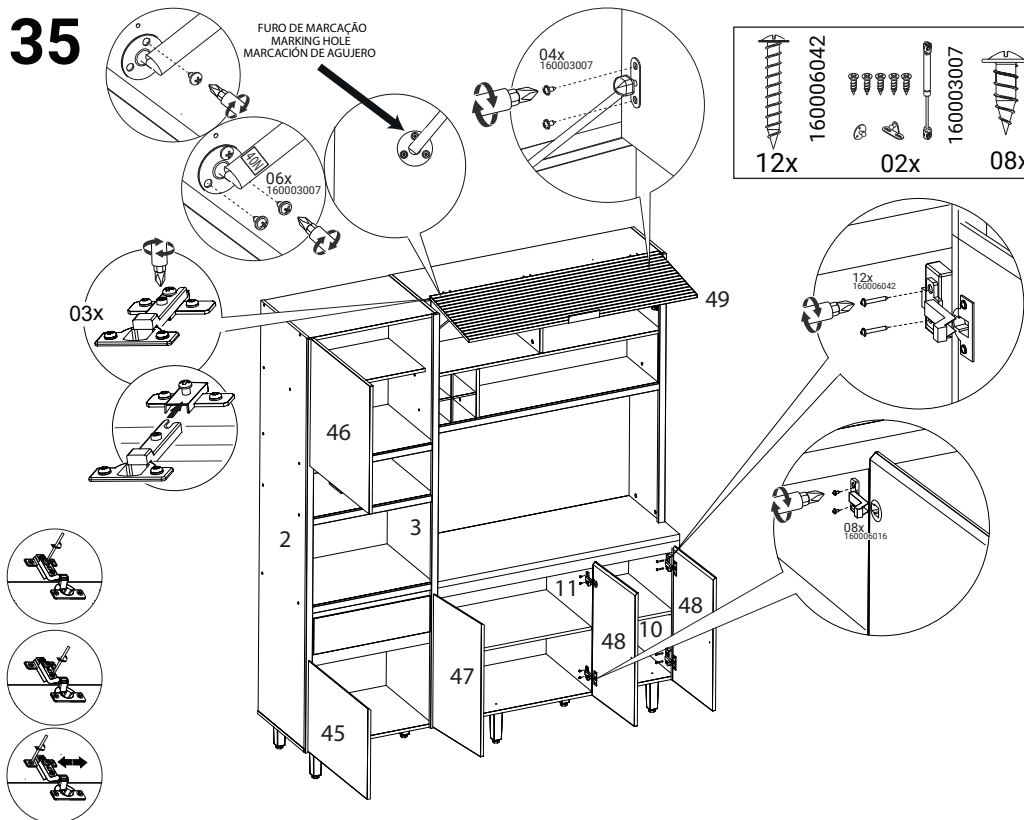
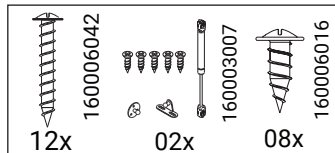

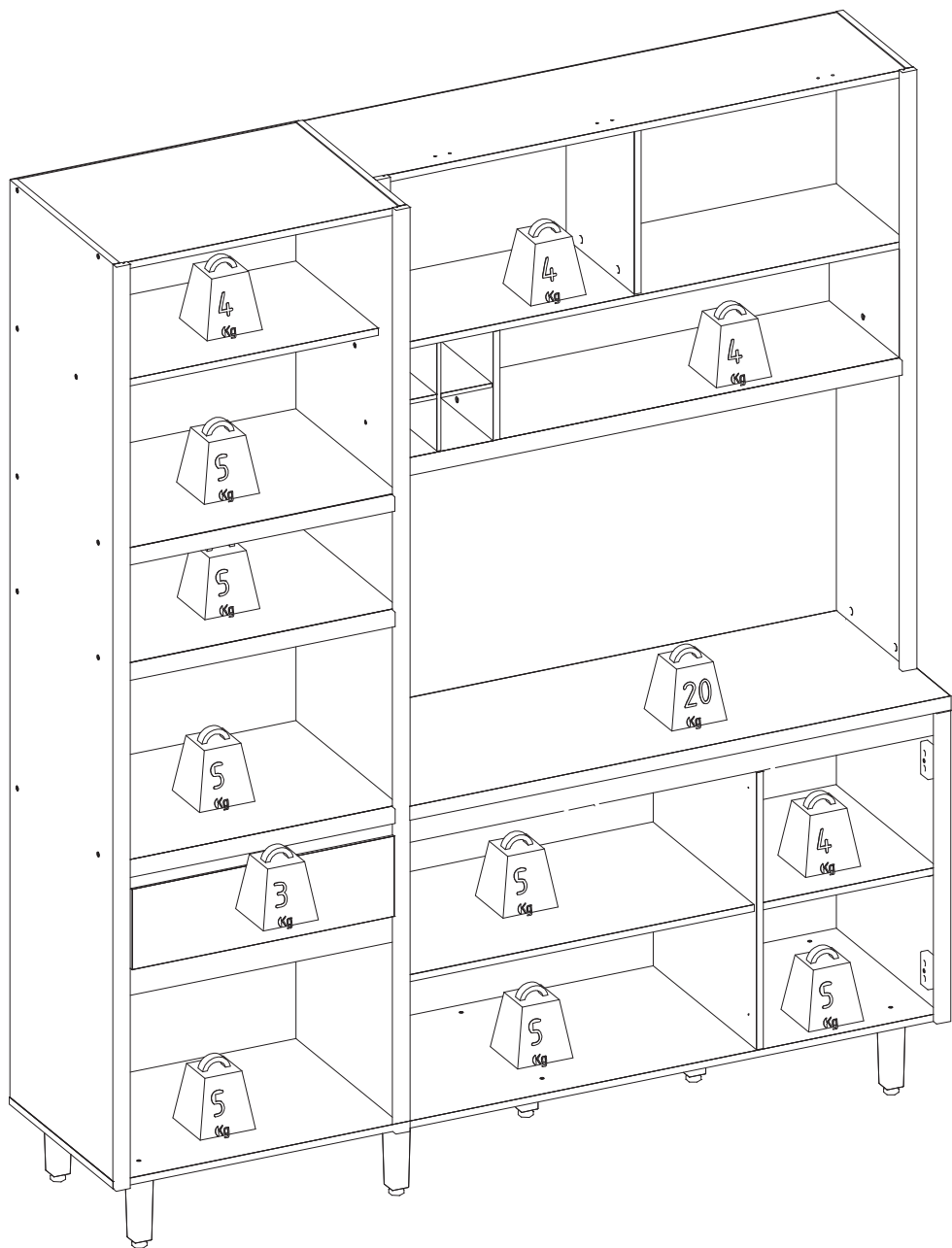

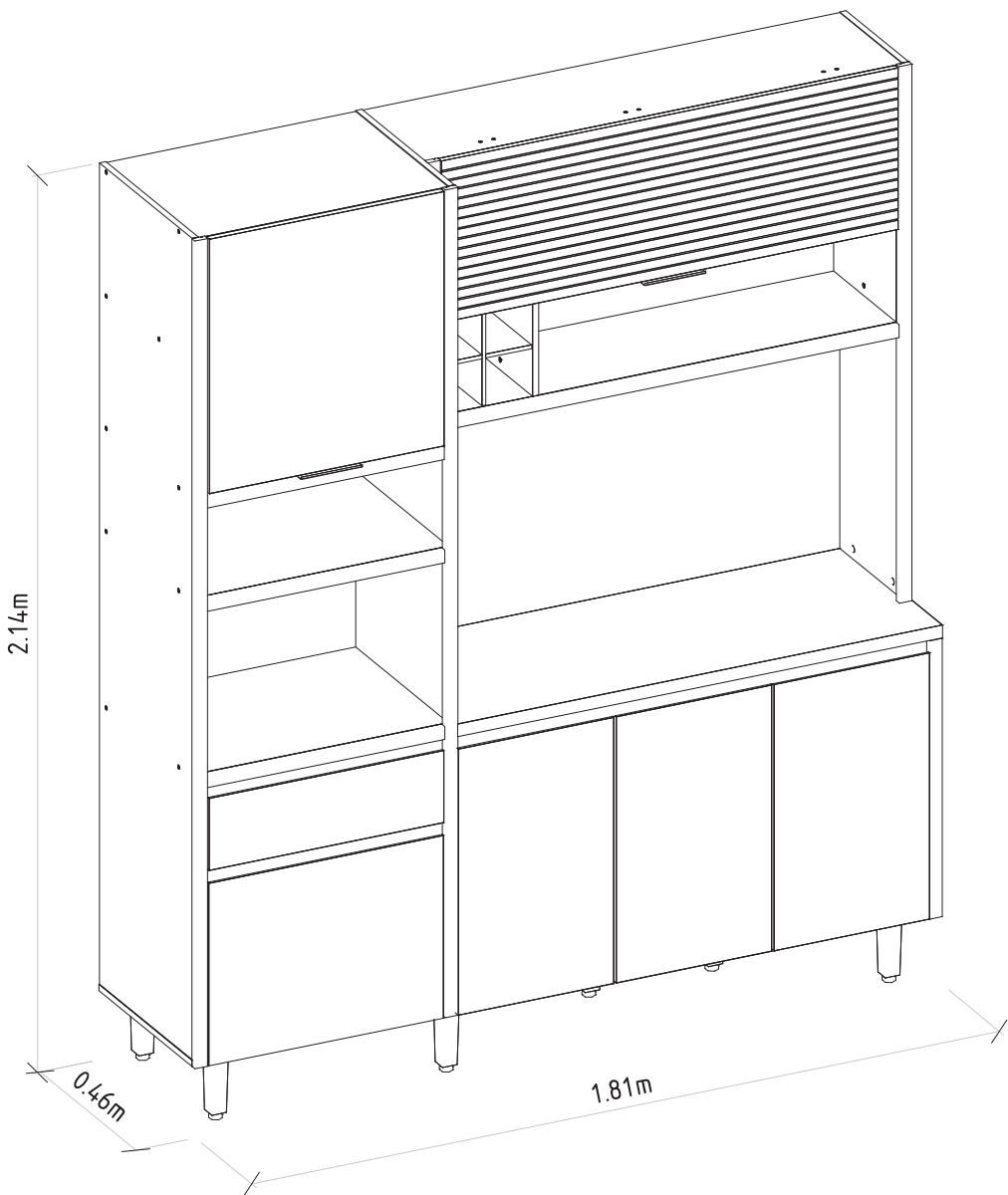

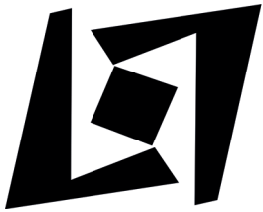

**Linea** Brasil