

# HENN

Ind. e Com. de Móveis Henn  
Mondaí - SC - Brasil

+55 49 3674.3500

@moveishenn  
www.henn.com.br

## INSTRUÇÕES DE MONTAGEM

INSTRUCCIONES DE MONTAJE  
ASSEMBLY INSTRUCTIONS

Balcão Pia 03 Gavetas 02 portas Americana |  
Pia Contador 03 Cajones 02 Puertas Americana | Balcony Pia 03 Drawers 02 Doors Americana |

C353-05 Branco HP  
C353-131 Cinza

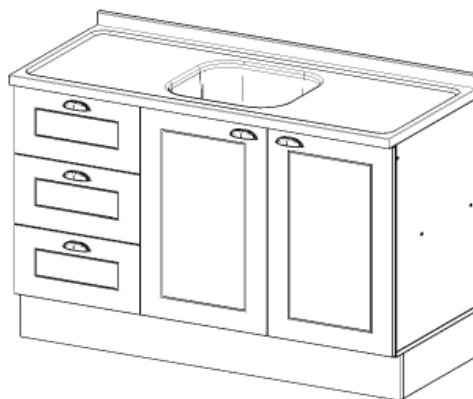
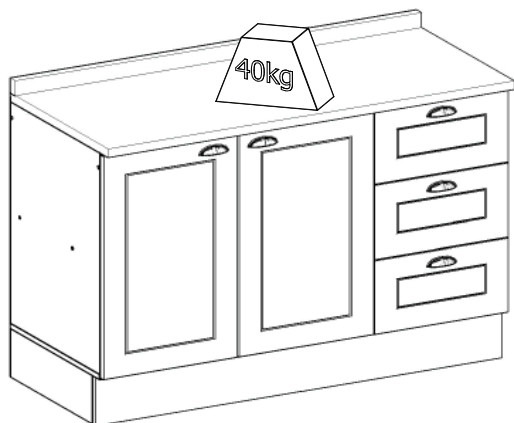
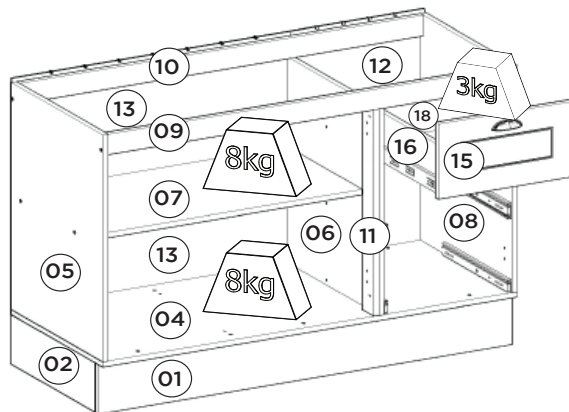
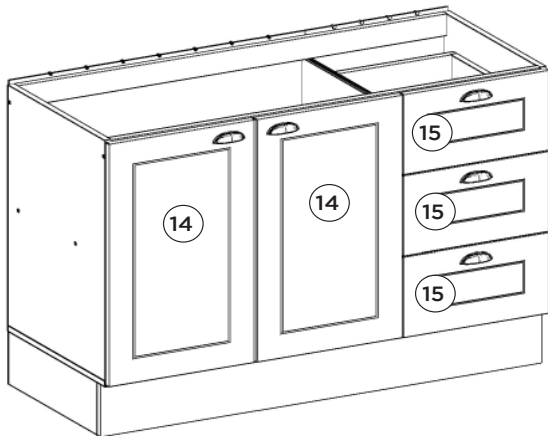

Pesos máximos recomendados  
com carga distribuída  
Peso máximo recomendado con la  
carga distribuída  
Recommended maximum weights  
with evenly distributed.

Requisitos para montagem  
Requisitor para la montaje  
Assembly Requirements

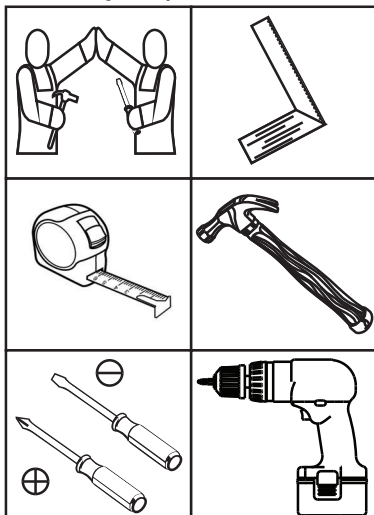

Imagens meramente ilustrativas  
Imágenes meramente ilustrativas  
Images for illustration only

### AVISO

Para limpeza de seu móvel, use uma flanela seca ou umedecida, e não utilize produtos químicos que possam danificar seu produto.

### SISTEMA DE MONTAGEM

O sistema de montagem dos produtos, funciona de acordo com a ordem crescente dos números indicados no desenho. Ex: 01, 02, 03, 04... até a conclusão da montagem.

### ASSISTÊNCIA TÉCNICA

Para solicitação de Assistência Técnica você consumidor deverá entrar em contato com o Lojista o qual você realizou a compra deste produto e solicitar a assistência técnica das peças avariadas. A garantia abrange todas as peças, partes e componentes que eventualmente venham apresentar defeito de fabricação no prazo de 03 (três) meses, contando a partir da entrega do produto ao consumidor, mediante nota fiscal de compra. Se houver qualquer alteração na estrutura do produto ou ocorrer defeito por negligência do montador/consumidor em relação a instrução de montagem e manuseio, não será fornecido assistência técnica gratuita.

### ADVERTENCIA

Para limpieza de su móvil, use una flanela seca o húmeda, y no utilice productos químicos que puedan dañar su producto.

### SISTEMA DE MONTAJE

El sistema de montaje de los productos funciona de acuerdo con el orden creciente de los números indicados en el dibujo. Ej.: 01, 02, 03, 04... hasta la conclusión del montaje.

### ASISTENCIA TÉCNICA

Para solicitar Asistencia Técnica, el consumidor debe comunicarse con el Comercio que usted realizó la compra de este producto y solicita asistencia técnica para las partes dañadas. La garantía cubre todas las partes, piezas y componentes que eventualmente puedan presentar defecto de fabricación en el plazo de 03 (tres) meses, contados a partir de la entrega del producto al consumidor, mediante factura de compra. Si se produce algún cambio en la estructura del producto o se produce un defecto por negligencia del montador/consumidor en relación con las instrucciones de montaje y manipulación, no se prestará asistencia técnica gratuita.

### NOTICE

To clean your furniture, use a dry or wet cloth, and do not use chemicals that may damage your product.

### ASSEMBLY SYSTEM

The products' assembly system works according to the increasing order of the indicated numbers. For example: 01, 02, 03, 04 ... to the end of the assembly.

### TECHNICAL ASSISTANCE

To request Technical Assistance, the consumer must contact the retailer from whom you purchased this product and request technical assistance for the damaged parts. The warranty covers all parts, parts and components that may eventually present a manufacturing defect within a period of 03 (three) months, counting from the delivery of the product to the consumer, by means of a purchase invoice. If there is any change in the structure of the product or defect occurs due to negligence of the assembler/consumer in relation to the assembly and handling instruction, free technical assistance will not be provided.

1

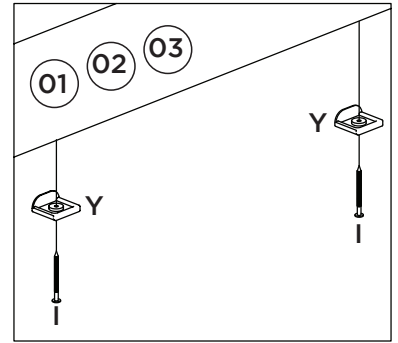
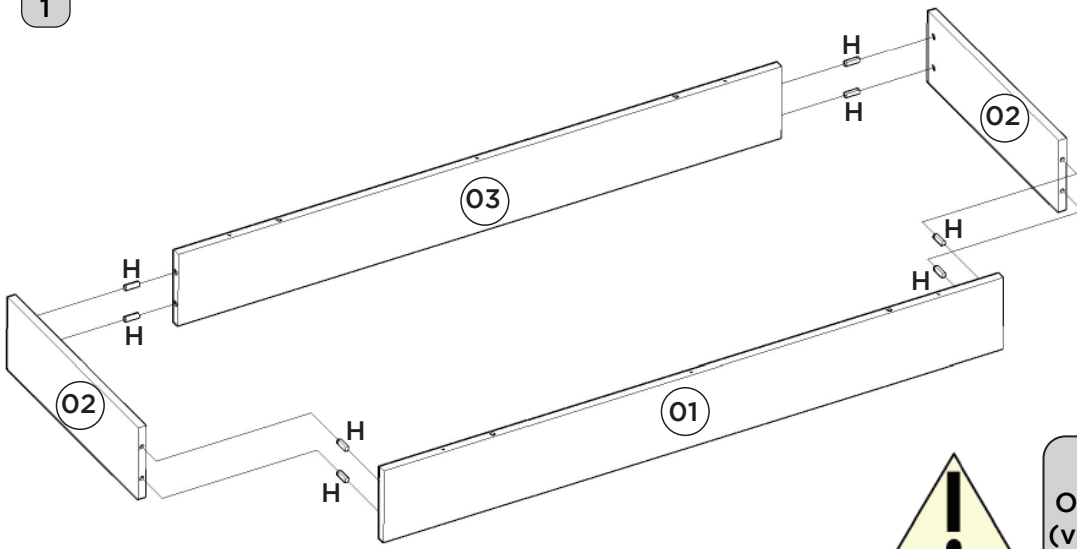

**OPCIONAL:**  
 O945-121 Kit Pé Cônico 145mm (vendido separadamente). Caso opte em colocar pé no produto, utilizar as pré-furações que possui na Base e fixá-lo com o Parafuso que consta no Kit.

**OPCIONAL:**  
 O945-121 Kit Pie Cónico 145mm (se vende por separado). Si opta por colocar pie en el producto, utilizar las pre-huracuras que tenga en la Base y fijarlo con el Tornillo que consta en el Kit.

**OPTIONAL:**  
 O945-121 Tapered Foot Kit 145mm (sold separately). If you choose to put foot in the product, use the pre-drillings in the Base and fix it with the Screw included in the Kit.

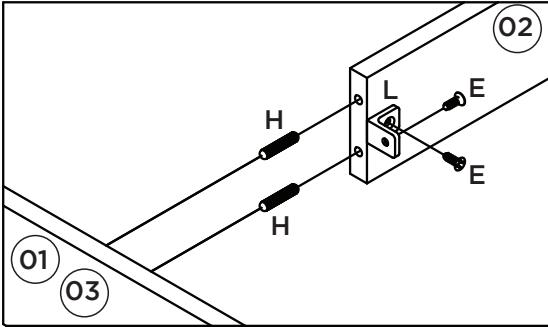

2

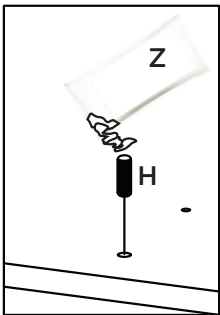

Utilizar o sachê de cola (Z) em todas as cavilhas (H) do produto.

Con el pegamento sobre (Z) en todos los pernos (H) producto.

Use the glue sachet (Z) on all the pegs (H) of the product.

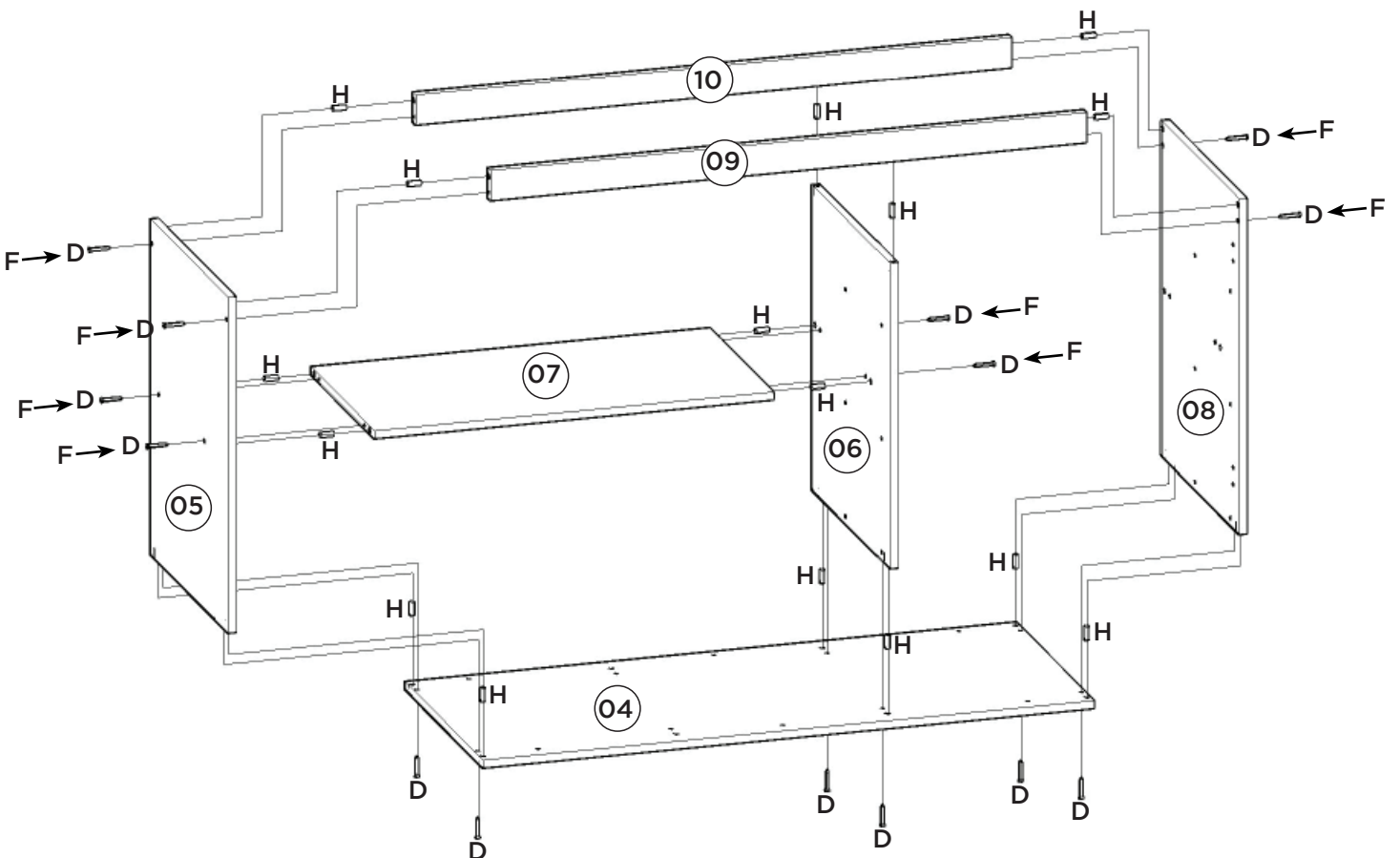

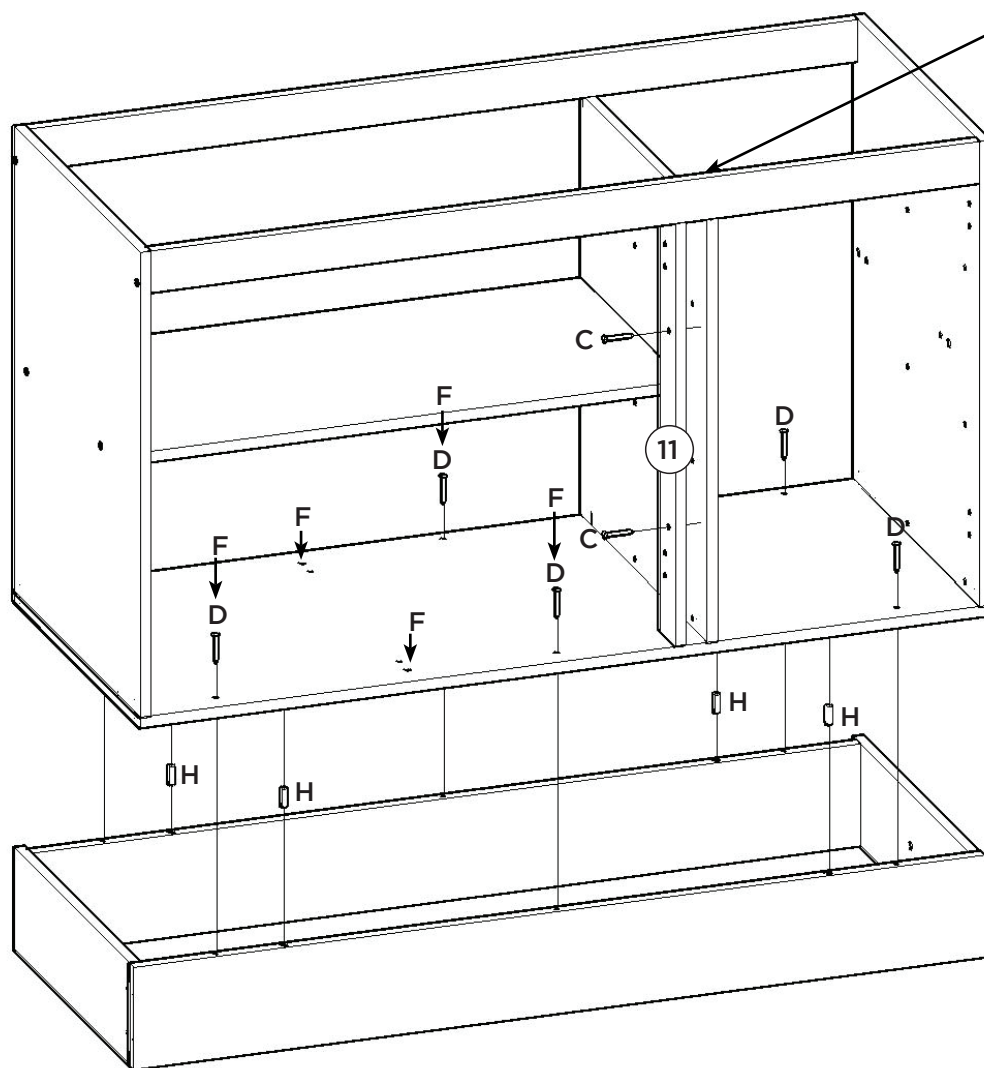

A pilastra da porta (11) deve estar alinhada com a divisão (06).

El pilar de la puerta (11) debe estar alineado con la división (06).

The door pillar (11) must be aligned with the partition (06).

4

Esse tampo é opcional e é vendido separadamente (C905-114).

Esta vez es opcional y se vende por separado (C905-114).

This top is optional and is sold separately (C905-114).

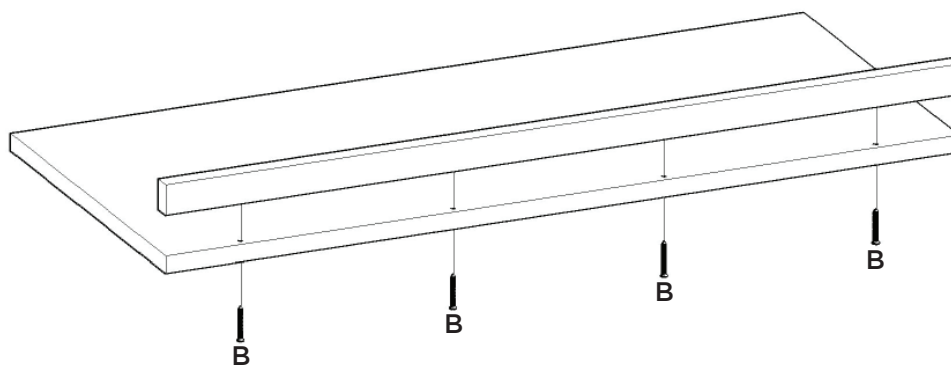

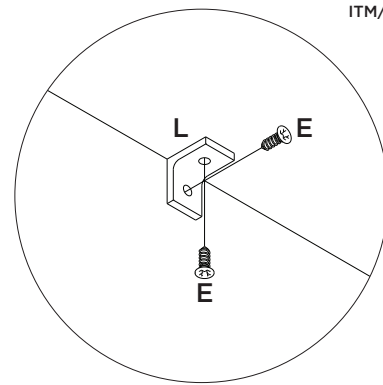
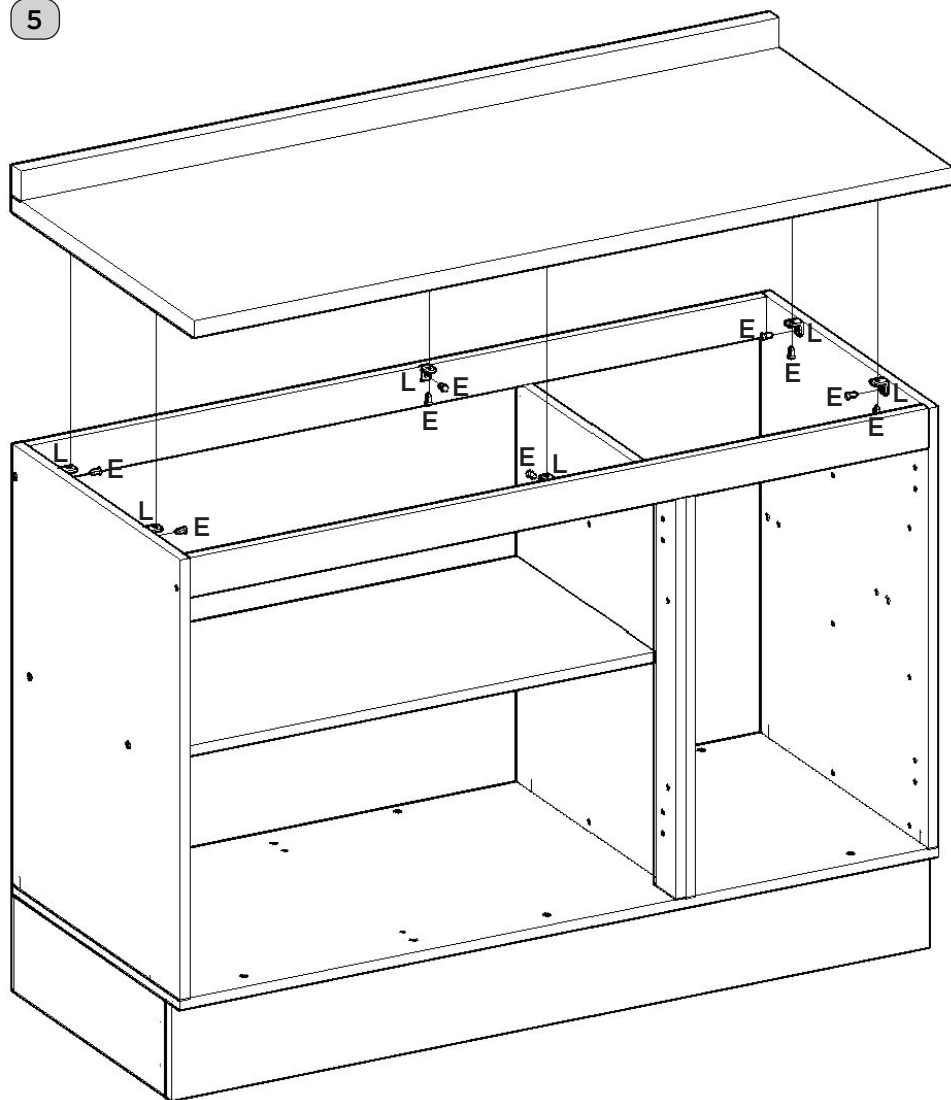

Caso o móvel seja montado com a opção do tampo, fixar o mesmo com 06 cantoneiras (L) e os parafusos 4,0x14mm (E).

Si se monta el auricular con la opción de la cubierta, fijarlo con Los ángulos 06 (L) y 4,0x14mm tornillos (E).

If the furniture is to be installed with the top cover option, fix it with 06 (L) and 4,0x14mm screws (E).

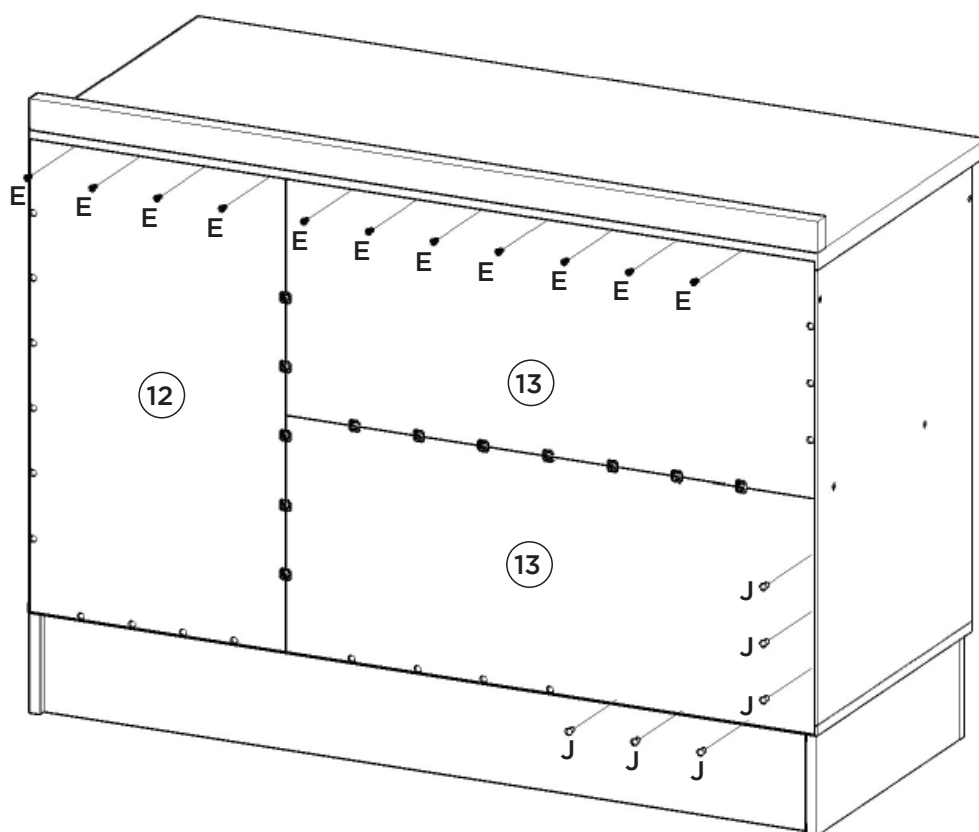
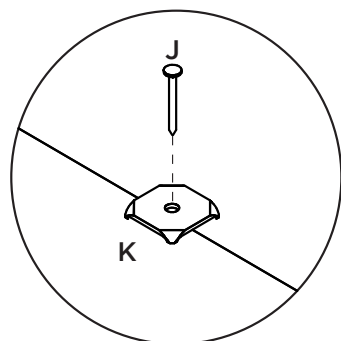

7

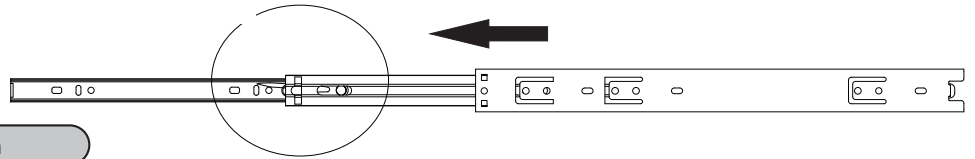
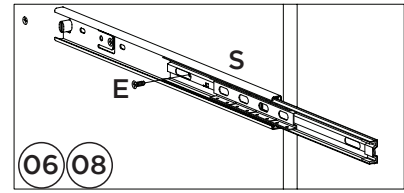
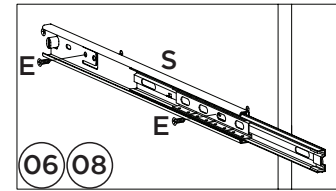
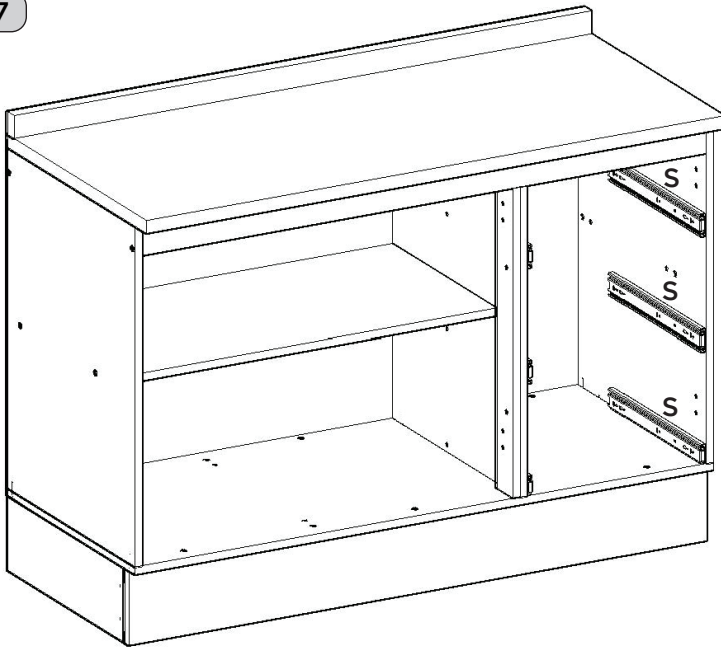

Vídeo: Dicas para fixar a Corrediça

Video: Consejos para arreglar la diapositiva

Video: Tips for Fixing the Slide



Para a desmontagem da corrediça siga a instrução ao lado.

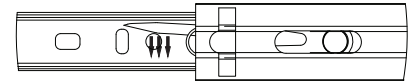

Para el desmontaje seguimiento de diapositivas la instrucción siguiente a.

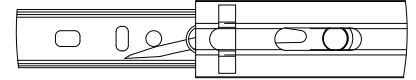

Fixar as corrediças nessas furações  
Fijar las diapositivas de estos agujeros

8

Opção Suspensa

Opción suspendida

Suspended Option

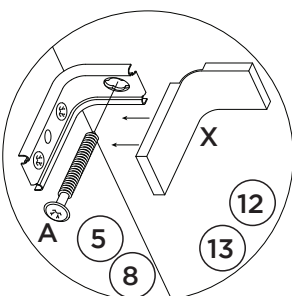
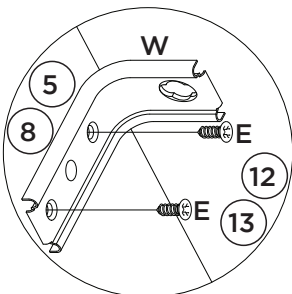

Parede  
pared  
Wall

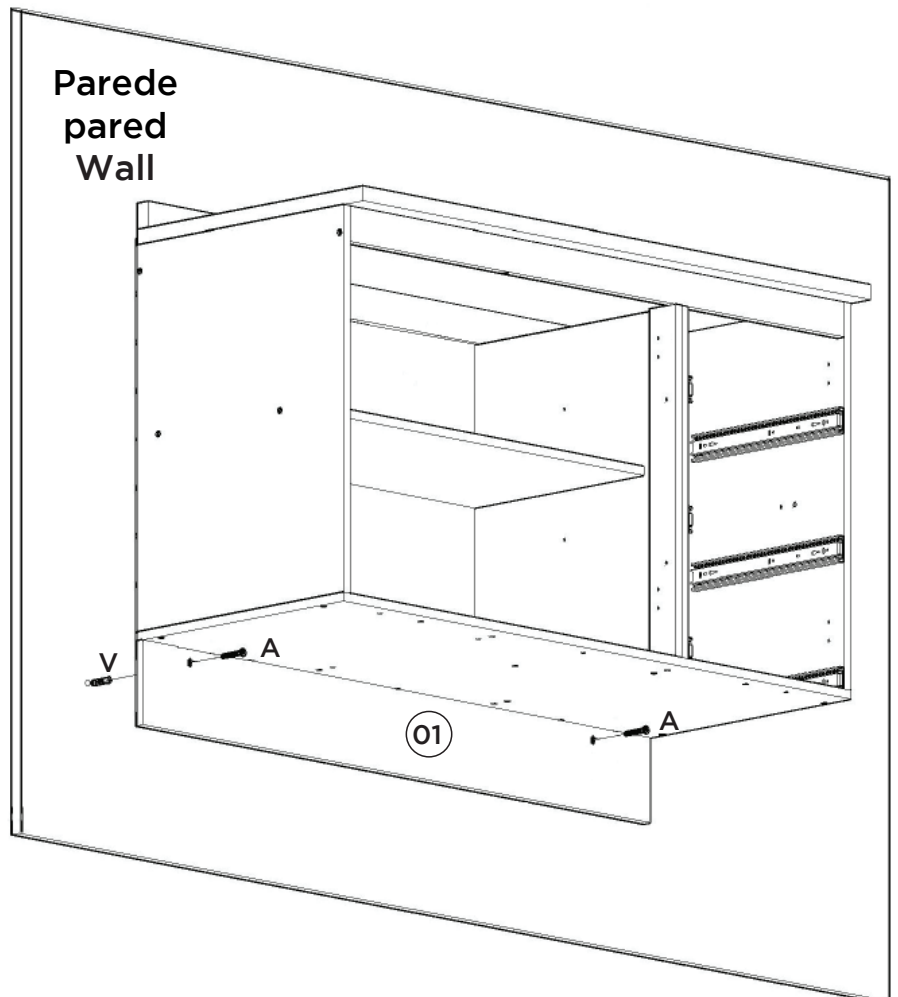

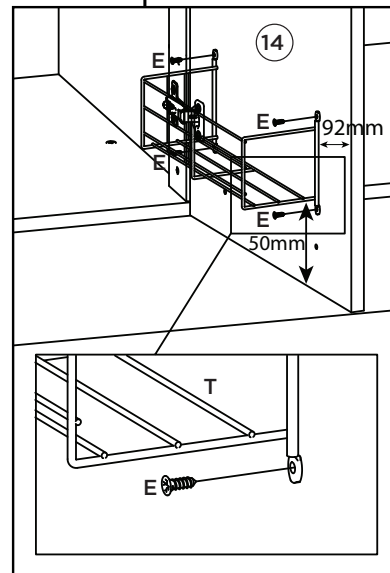
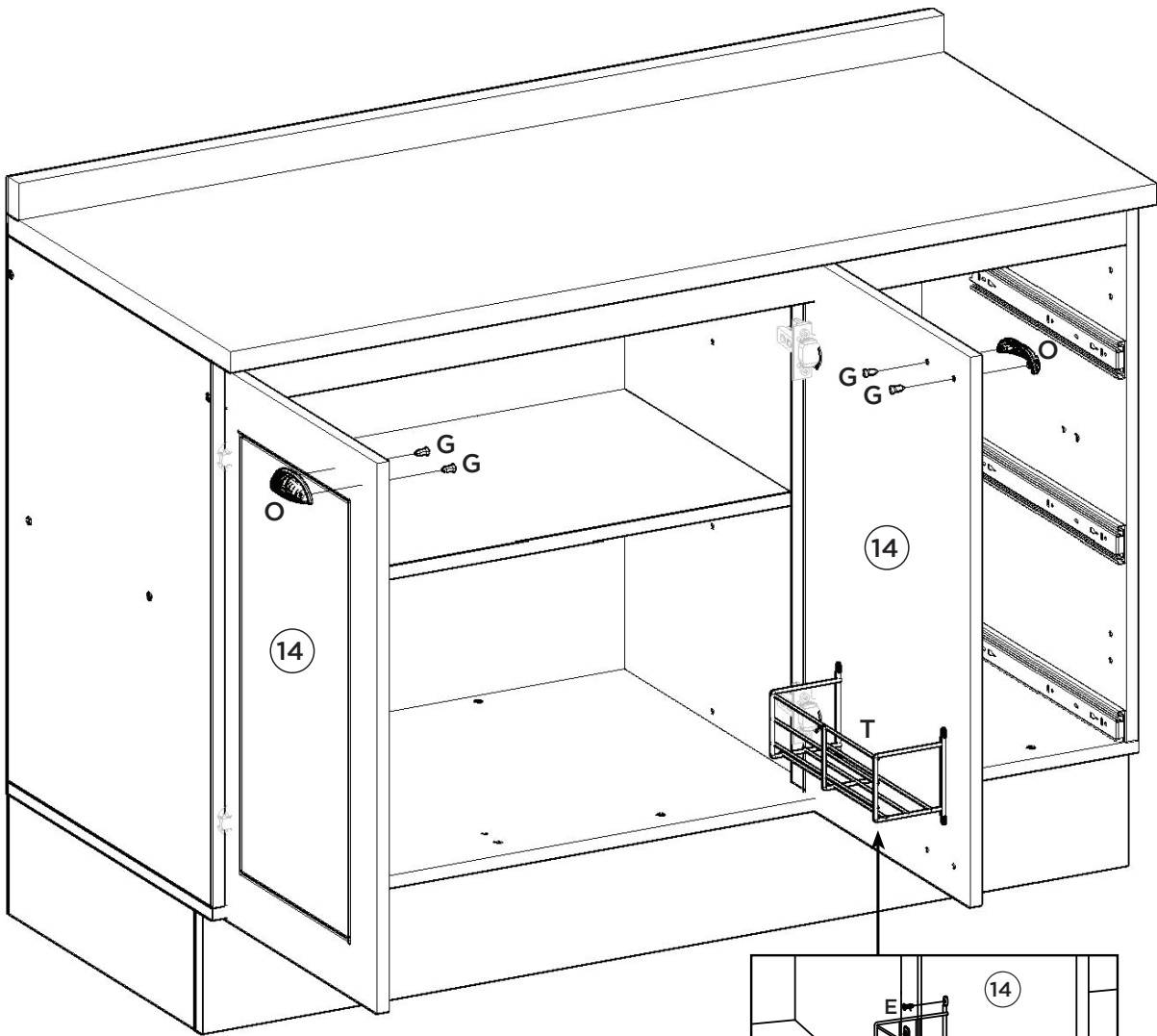
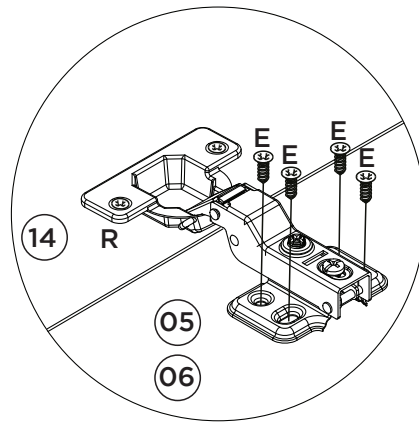
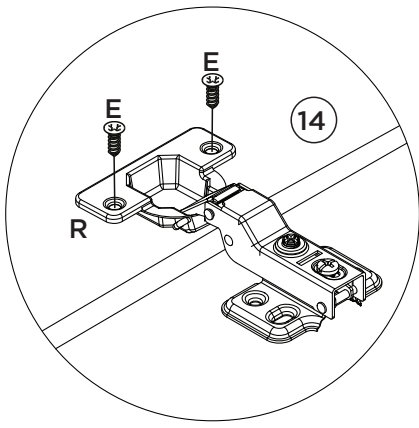

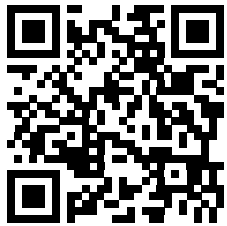
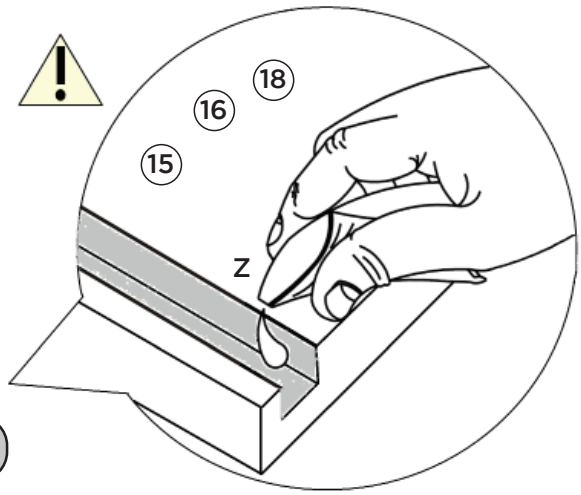
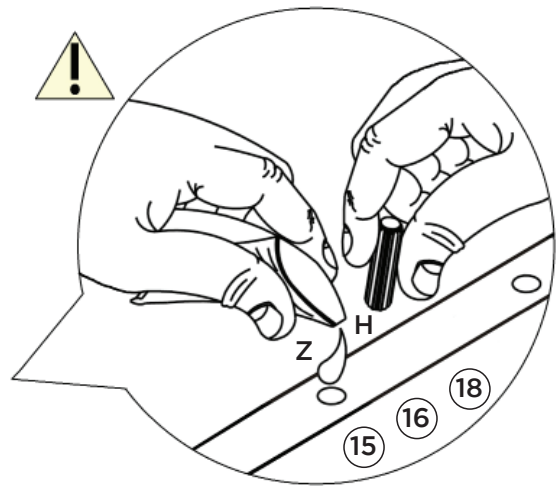
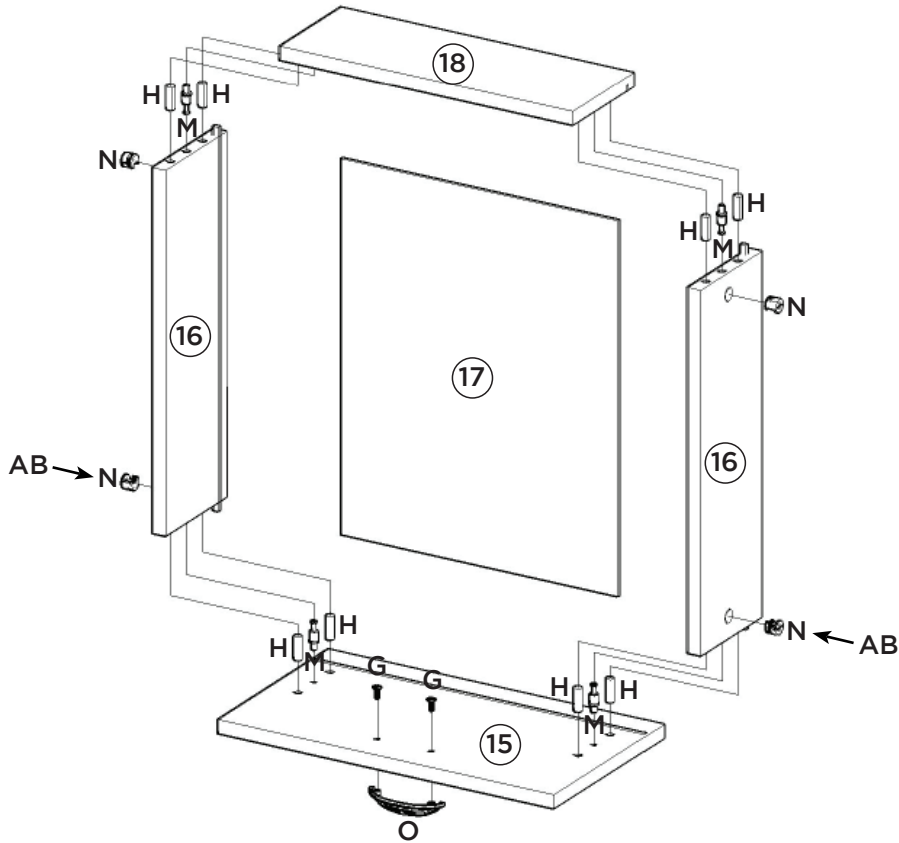

- Vídeo: Dicas para fixar o Minifix
- Video: Consejos para arreglar Minifix
- Video: Tips for Fixing Minifix

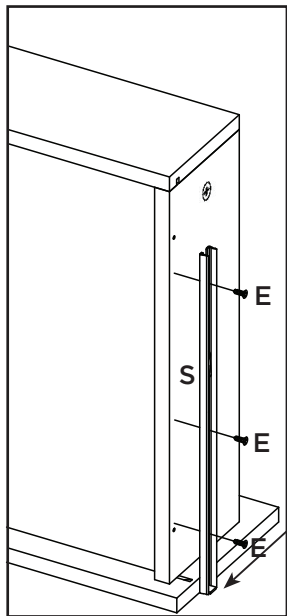
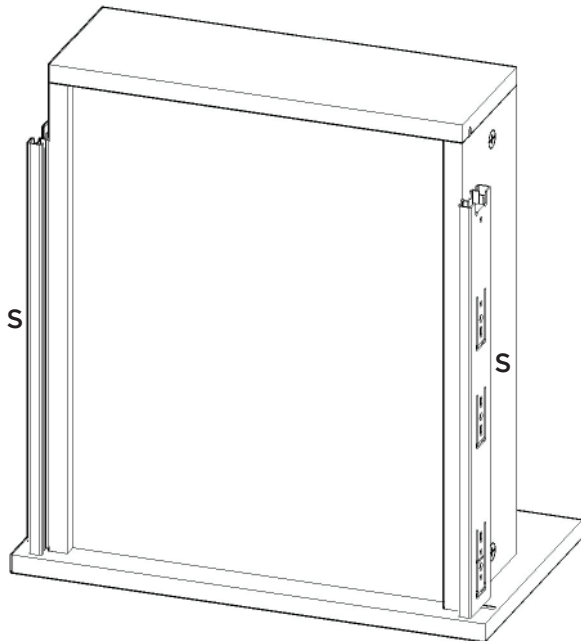









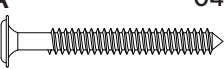



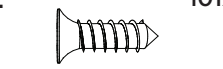
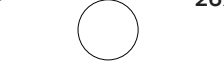



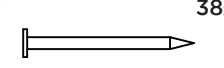





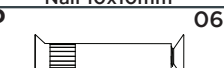

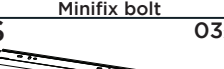
- Deixar 3mm de distância da frente de gaveta.
- Deje una separación de 3mm del frente del cajón.
- Leave 3mm away from the front of the drawer.

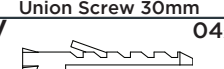
## Lista de Peças | Lista de piezas | List of parts

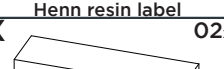
Item	Caixa Caja Box	Qtd Ctd Qty	Descrição   Descripción   Description	Medidas (mm)   Dimensions (mm)   Size (measurements) (mm)
01	1/1	01	Rodapé Frontal   Frente pie de página   Front Footer	1200x145x15
02	1/1	02	Rodapé Lateral   Pie de página Side   Side Footer	450x145x15
03	1/1	01	Rodapé Traseiro   Pie de página trasera   Rear Footer	1168x145x15
04	1/1	01	Base   Base   Base	1200x490x15
05	1/1	01	Lateral esquerda   Lateral izquierda   Left side	660x490x15
06	1/1	01	Divisão   División   Division	600x490x15
07	1/1	01	Prateleira   Estante   Shelf	784x400x15
08	1/1	01	Lateral direita   Lateral derecha   Right side	660x490x15
09	1/1	01	Travessa frontal   Travesaño frontal   Front crossbar	1169x60x15
10	1/1	01	Travessa traseira   Travesaño trasero   Rear bumper	1169x60x15
11	1/1	01	Pilastra da Porta   Pilastra Puerta   Pilaster door	599x60x15
12	1/1	01	Fundo Lateral   Fondo Lateral   Lateral Background	683x389x3
13	1/1	02	Fundo   Fondo   Bottom	803x341x3
14	1/1	02	Porta   Puerta   Door	665x396x15
15	1/1	03	Frente de gaveta   Frente de cajón   Front of drawer	396x220x15
16	1/1	06	Lado de Gaveta   Lado del cajón   Drawer Side	400x122x15
17	1/1	03	Fundo de gaveta   Fondo de cajón   Bottom of drawer	411x326x3
18	1/1	03	Ripa de trás   Malla detrás   Rear lath	345x122x15

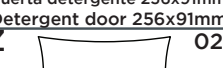
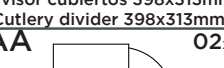
## Ferragens | Herrajes | Hardware

<b>A</b>  Parafuso 5,0x50mm FLA. Tornillo 5,0x50mm FLA. Screw 5,0x50mm FLA.	<b>B</b>  Parafuso 4,5x50mm CHT. Tornillo 4,5x50mm CHT. Screw 4,5x50mm CHT.	<b>C</b>  Parafuso 4,0x25mm CHT. Tornillo 4,0x25mm CHT. Screw 4,0x25mm CHT.	<b>D</b>  Parafuso 3,5x40mm CHT. Tornillo 3,5x40mm CHT. Screw 3,5x40mm CHT.	<b>E</b>  Parafuso 4,0x14mm CHT. Tornillo 4,0x14mm CHT. Screw 4,0x14mm CHT.	<b>F</b>  Adesivo tapa parafuso 10mm Adhesivo tapón de tornillo 10mm Bolt cover adhesive 10mm
<b>G</b>  Parafuso M4x20mm CHT. ZB Tornillo M4x20mm CHT. ZB Screw M4x20mm CHT. ZB	<b>H</b>  Cavilha 8x25mm Cinta 8x25mm Dowel 8x25mm	<b>I</b>  Prego 12x12mm Anelado Clavo 12x12mm Anillado Ringed Nails 12x12mm	<b>J</b>  Prego 10x10mm Clavo 10x10mm Nail 10x10mm	<b>K</b>  Fixador de fundos Fijador de fondos Bottom fixer	<b>L</b>  Cantoneira plástica Cantenera plástica Plastic angle brackets
<b>M</b>  Parafuso minifix Tornillo minifix Minifix bolt	<b>N</b>  Tambor minifix Tambor minifix Minifix drum	<b>O</b>  Puxador Concha Tirador Concha Shell Handle	<b>P</b>  Parafuso União 30mm Tornillo Unión 30mm Union Screw 30mm	<b>Q</b>  Dobradica 35mm POP Baixa c Amort + Calço Fixo Bisagra baja POP de 35 mm con amortiguación + cuña fija 35mm POP Low Hinge with Damping + Fixed Shim	<b>R</b>  Etiqueta resinada Henn Etiqueta resinada Henn Henn resin label
<b>S</b>  Corrediça telescópica Diapositivas telescópicas Telescopic slides	<b>T</b>  Porta detergente 256x91mm Puerta detergente 256x91mm Detergent door 256x91mm	<b>U</b>  Divisor talheres 398x313mm Divisor cubiertos 398x313mm Cutlery divider 398x313mm	<b>V</b>  Bucha plástica 8mm Bucha de plástico 8mm 8mm plastic bushing	<b>W</b>  Suporte de fixação Soporte de fijación Mounting bracket	<b>X</b>  Proteção para cantoneira Ángulo de protección Protection angle
<b>Y</b>  Sapata "L" 16x20mm Zapata "L" 16x20mm "L" shoe 16x20mm	<b>Z</b>  Sachê de cola Bolsa de pegamento Glue bag	<b>AA</b>  Giz de correção Tiza de corrección Chalk of correction	<b>AB</b>  Adesivo tapa parafuso 17mm Adhesivo tapón de tornillo 17mm Bolt cover adhesive 17mm		



O parafuso (P) deve ser usada somente quando este módulo for acoplado a outro módulo componível Henn.

## RECOMENDAÇÃO

Para fixar o móvel na parede usar o suporte de fixação (W), o parafuso 4,0x14mm CHT (E), a Bucha 8mm (V) e o parafuso 5,0x50mm FLA (A).



El tornillo (P) se debe utilizar sólo cuando el módulo está conectado a otro módulo componible Henn.

## RECOMENDACIÓN

Para conectar el móvil a la pared con el soporte (W), tornillo 4,0x14mm CHT (E), el casquillo de 8 mm (V) y el 5,0 x50mm tornillo FLA (A).



The screw (P) should be used only when this module is attached to another Henn modular module.

## RECOMMENDATION

To fix the furniture to the wall use the mounting bracket (W), the 4,0x14mm CHT (E) screw, the 8mm bushing (V) and the 5,0x50mm FLA screw (A).



**HENN**Ind. e Com. de Móveis Henn  
Mondai - SC - Brasil

☎ +55 49 3674.3500

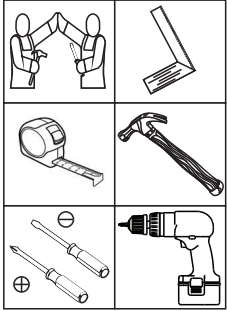
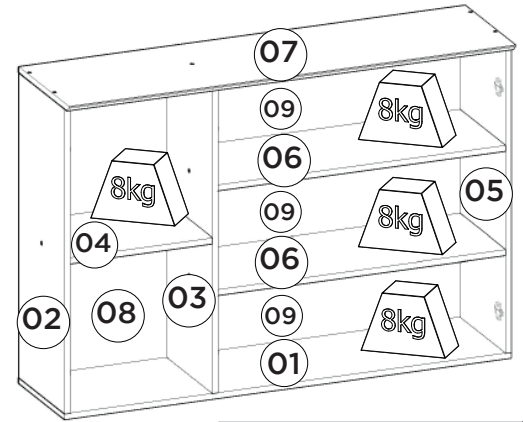
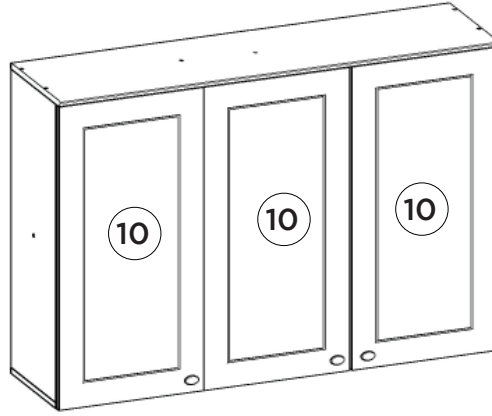
📷 @moveishenn  
www.henn.com.br**INSTRUÇÕES DE MONTAGEM****INSTRUCCIONES DE MONTAJE  
ASSEMBLY INSTRUCTIONS****Aéreo 03 Portas 1200mm Americana | Aéreo 03 Puertas 1200mm Americana |  
Aerial 03 Doors 1200mm Americana**Referência/Cor  
c C352-05 Branco HP  
c C352-131 CinzaRequisitos para montagem  
Requisitos para la montaje  
Assembly RequirementsImagens meramente ilustrativas  
Imágenes meramente ilustrativas  
Images for illustration only**Pesos máximos recomendados com carga distribuída  
Peso máximo recomendado con la carga distribuida  
Recommended maximum weight with distributed load.****AVISO**

Para limpeza de seu móvel, use uma flanela seca ou umedecida, e não utilize produtos químicos que possam danificar seu produto.

**SISTEMA DE MONTAGEM**

O sistema de montagem dos produtos, funciona de acordo com a ordem crescente dos números indicados no desenho. Ex: 01, 02, 03, 04... até a conclusão da montagem.

**ASSISTÊNCIA TÉCNICA**

Para solicitação de Assistência Técnica você consumidor deverá entrar em contato com o Lojista a qual você realizou a compra deste produto e solicitar a assistência técnica das peças avariadas. A garantia abrange todas as peças, partes e componentes que eventualmente venham apresentar defeito de fabricação no prazo de 03 (três) meses, contando a partir da entrega do produto ao consumidor, mediante nota fiscal de compra. Se houver qualquer alteração na estrutura do produto ou ocorrer defeito por negligência do montador/consumidor em relação a instrução de montagem e manuseio, não será fornecido assistência técnica gratuita.

**ADVERTENCIA**

Para limpieza de su móvil, use una flanela seca o húmeda, y no utilice productos químicos que puedan dañar su producto.

**SISTEMA DE MONTAJE**

El sistema de montaje de los productos funciona de acuerdo con el orden creciente de los números indicados en el dibujo. Ej: 01, 02, 03, 04... hasta la conclusión del montaje.

**ASISTENCIA TÉCNICA**

Para solicitar Asistencia Técnica, el consumidor debe comunicarse con el Comercio que usted realizó la compra de este producto y solicita asistencia técnica para las partes dañadas. La garantía cubre todas las partes, piezas y componentes que eventualmente puedan presentar defecto de fabricación en el plazo de 03 (tres) meses, contados a partir de la entrega del producto al consumidor, mediante factura de compra. Si se produce algún cambio en la estructura del producto o se produce un defecto por negligencia del montador/consumidor en relación con las instrucciones de montaje y manipulación, no se prestará asistencia técnica gratuita.

**NOTICE**

To clean your furniture, use a dry or wet cloth, and do not use chemicals that may damage your product.

**ASSEMBLY SYSTEM**

The products' assembly system works according to the increasing order of the indicated numbers. For example: 01, 02, 03, 04 ... to the end of the assembly.

**TECHNICAL ASSISTANCE**

To request Technical Assistance, the consumer must contact the retailer from whom you purchased this product and request technical assistance for the damaged parts. The warranty covers all parts, parts and components that may eventually present a manufacturing defect within a period of 03 (three) months, counting from the delivery of the product to the consumer, by means of a purchase invoice. If there is any change in the structure of the product or defect occurs due to negligence of the assembler/consumer in relation to the assembly and handling instruction, free technical assistance will not be provided.

**Lista de Peças | Lista de piezas | List of parts**

Item	Caixa Caja Box	Qtd Ctd Qty	Descrição   Descripción   Description	Medidas (mm)   Dimensions (mm)   Size (measurements) (mm)
01	1/1	01	Base   Base   Base	1200x295x15
02	1/1	01	Lateral Esquerda   Lateral Izquierda   Right Left	800x295x15
03	1/1	01	Divisão   División   Division	800x295x15
04	1/1	01	Prateleira Menor   Estante Pequeño   Smaller Shelf	382x295x15
05	1/1	01	Lateral Direita   Lateral Derecha   Right Side	800x295x15
06	1/1	02	Prateleira   Estante   Shelf	772x295x15
07	1/1	01	Tampo   Tapa   Top	1200x322x15
08	1/1	01	Fundo Lateral   Fondo Lateral   Lateral Background	824x401x3
09	1/1	03	Fundo   Fondo   Bottom	791x274x3
10	1/1	03	Porta   Puerta   Door	813x396x15

**Ferragens | Herrajes | Hardware**

<b>A</b> 03x  Parafuso 5,0x50mm FLA. Tornillo 5,0x50mm FLA. Screw 5,0x50mm FLA.	<b>B</b> 16x  Parafuso 3,5x40mm CHT. Tornillo 3,5x40mm CHT. Screw 3,5x40mm CHT.	<b>C</b> 42x  Parafuso 4,0x14mm CHT. Tornillo 4,0x14mm CHT. Screw 4,0x14mm CHT.	<b>D</b> 03x  Parafuso M4x20mm CHT. ZB Tornillo M4x20mm CHT. ZB Screw M4x20mm CHT. ZB	<b>E</b> 24x  Cavilha 8x25mm Cinta 8x25mm Dowel 8x25mm	<b>F</b> 06x  Bisagra baja POP de 35 mm con amortiguación + calca fija 35mm POP Low Hinge with Damping + Fixed Shim
<b>G</b> 01x  Etiqueta resinada Henn Etiqueta resinada Henn Henn resin label	<b>H</b> 03x  Puxador Pontual PZ14 Oval Tirador Puntual PZ14 Oval PZ14 Oval Point Knob	<b>I</b> 03x  Bucha plástica 8mm Bucha de plástico 8mm 8mm plastic bushing	<b>J</b> 03x  Suporte de fixação Soporte de fijación Mounting bracket	<b>K</b> 03x  Proteção para cantoneira Ángulo de protección Protection angle	<b>L</b> 04x  Parafuso União 30mm Tornillo Unión 30mm Union Screw 30mm
<b>M</b> 02x  Giz de correção Tiza de corrección Chalk of correction	<b>N</b> 02x  Sachê de cola Bolsa de pegamento Glue bag	<b>O</b> 19x  Adesivo tapa parafuso 10mm Adhesivo tapón de tornillo 10mm Bolt cover adhesive 10mm	<b>P</b> 21x  Fixador de fundos Fijador de fondos Bottom fixer	<b>Q</b> 66x  Prego 10x10mm Clavo 10x10mm Nail 10x10mm	

  
O parafuso (L) deve ser usada somente quando este módulo for acoplado a outro módulo componível Henn.  
El tornillo (L) se debe utilizar sólo cuando el módulo está conectado a otro módulo componible Henn.  
The screw (L) should be used only when this module is attached to another Henn modular module.**RECOMENDAÇÃO**

Para fixar o móvel na parede usar o suporte de fixação (J), o parafuso 4,0x14mm CHT (C), a Bucha 8mm (I) e o parafuso 5,0x50mm FLA (A).

**RECOMENDACIÓN**

Para conectar el móvil a la pared con el soporte (J), tornillo 4,0x14mm CHT (C), el casquillo de 8 mm (I) y el 5,0 x50mm tornillo FLA (A).

**RECOMMENDATION**

To fix the furniture to the wall use the fixing bracket (J), the 4,0x14mm CHT (C) screw, the 8mm bushing (I) and the 5.0x50mm FLA (A).

1

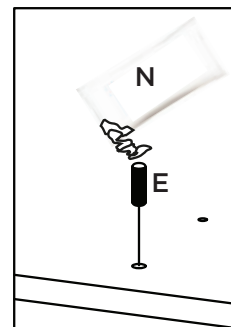
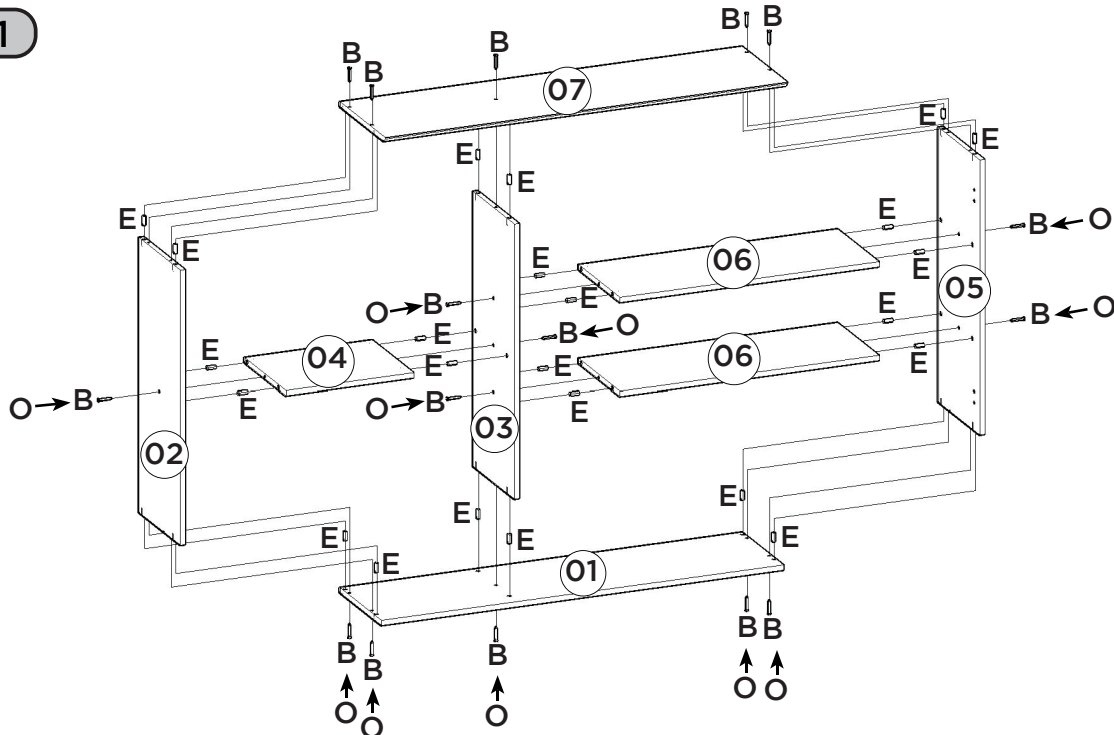

Utilizar o sachê de cola (N) em todas as cavilhas (E) do produto.

Con el pegamento sobre (N) en todos los pernos (E) producto.

Use the glue sachet (N) on all the pegs (E) of the product.

2

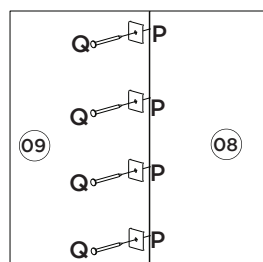
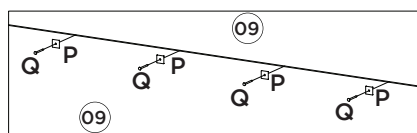
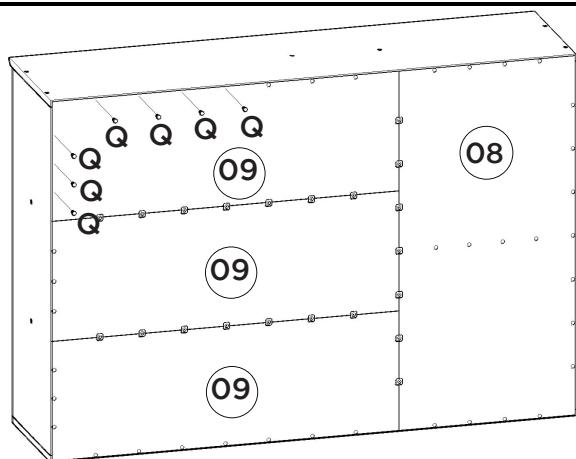

3

Para saber mais sobre como fixar o móvel de maneira correta, acesse:

Para obtener más información sobre cómo arreglar los muebles correctamente, visite:

To learn more about how to fix the furniture correctly, visit:

 <http://bit.ly/guia-de-fixacao-henn>



Imprescindível a fixação do produto na parede.

Es imprescindible la fijación del producto en la pared.

Indispensable to fix the product on the wall.

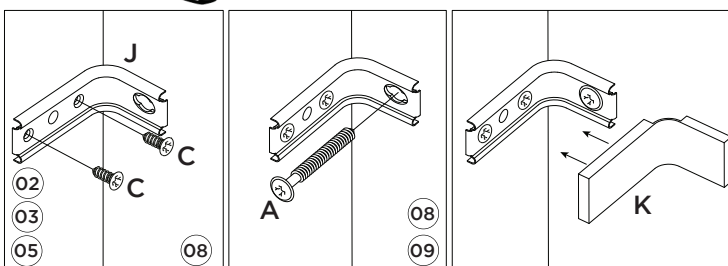

Para colocação dos puxadores, é necessário fazer a furação passante, com Broca de 5mm.

Para la colocación de las asas, es necesario perforar a través, con una broca de 5mm.

To place the handles is necessary to make the through hole, drill 5mm.

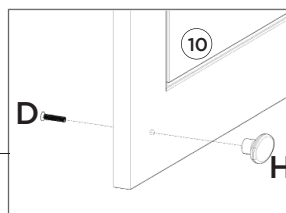
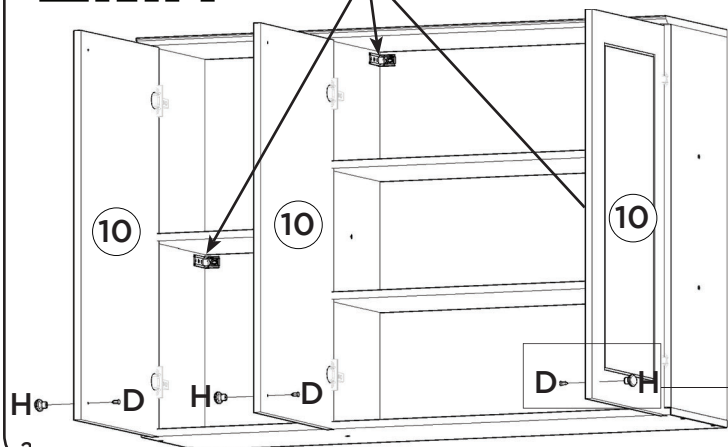
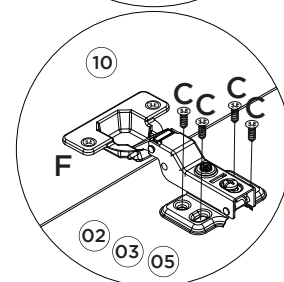
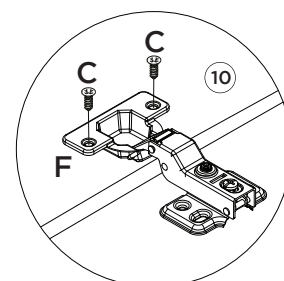

# HENN

Ind. e Com. de Móveis Henn  
Mondai - SC - Brasil

+55 49 3674.3500

@f@moveishenn  
www.henn.com.br

## INSTRUÇÕES DE MONTAGEM

INSTRUCCIONES DE MONTAJE  
ASSEMBLY INSTRUCTIONS

### Aéreo 01 Porta Basculante 800mm Americana | Aéreo 01 Puerta Basculante 800mm Americana | 01 air port Tipper 800mm Americana

c C354-05 Branco HP

c C354-131 Cinza

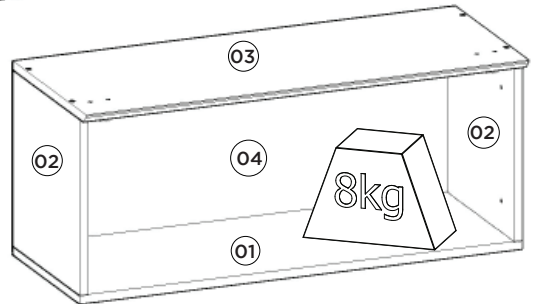
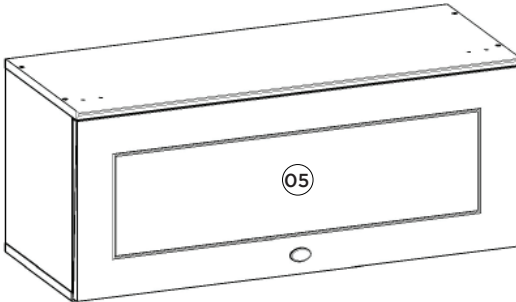

Pesos máximos recomendados  
com carga distribuída  
Peso máximo recomendado com  
a carga distribuída  
Recommended maximum weight  
with distributed load.

Requisitos para montagem  
Requisitos para la montaje  
Assembly Requirements

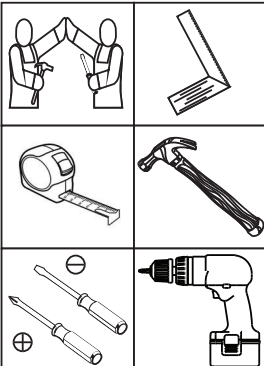

Imagens meramente ilustrativas  
Imágenes meramente ilustrativas  
Images for illustration only

#### AVISO

Para limpeza de seu móvel, use uma flanela seca ou umedecida, e não utilize produtos químicos que possam danificar seu produto.

#### SISTEMA DE MONTAGEM

O sistema de montagem dos produtos, funciona de acordo com a ordem crescente dos números indicados no desenho. Ex: 01, 02, 03, 04... até a conclusão da montagem.

#### ASSISTÊNCIA TÉCNICA

Para solicitação de Assistência Técnica você consumidor deverá entrar em contato com o Lojista o qual você realizou a compra deste produto e solicitar a assistência técnica das peças avariadas. A garantia abrange todas as peças, partes e componentes que eventualmente venham apresentar defeito de fabricação no prazo de 03 (três) meses, contando a partir da entrega do produto ao consumidor, mediante nota fiscal de compra. Se houver qualquer alteração na estrutura do produto ou ocorrer defeito por negligência do montador/consumidor em relação a instrução de montagem e manuseio, não será fornecido assistência técnica gratuita.

#### ADVERTENCIA

Para limpeza de su móvil, use una flanela seca o húmeda, y no utilice productos químicos que puedan dañar su producto.

#### SISTEMA DE MONTAJE

El sistema de montaje de los productos funciona de acuerdo con el orden creciente de los números indicados en el dibujo. Ej.: 01, 02, 03, 04... hasta la conclusión del montaje.

#### ASISTENCIA TÉCNICA

Para solicitar Asistencia Técnica, el consumidor debe comunicarse con el Comercio que usted realizó la compra de este producto y solicita asistencia técnica para las partes dañadas. La garantía cubre todas las partes, piezas y componentes que eventualmente puedan presentar defecto de fabricación en el plazo de 03 (tres) meses, contados a partir de la entrega del producto al consumidor, mediante factura de compra. Si se produce algún cambio en la estructura del producto o se produce un defecto por negligencia del montador/consumidor en relación con las instrucciones de montaje y manipulación, no se prestará asistencia técnica gratuita.

#### NOTICE

To clean your furniture, use a dry or wet cloth, and do not use chemicals that may damage your product.

#### ASSEMBLY SYSTEM

The products' assembly system works according to the increasing order of the indicated numbers. For example: 01, 02, 03, 04... to the end of the assembly.

#### TECHNICAL ASSISTANCE

To request Technical Assistance, the consumer must contact the retailer from whom you purchased this product and request technical assistance for the damaged parts. The warranty covers all parts, parts and components that may eventually present a manufacturing defect within a period of 03 (three) months, counting from the delivery of the product to the consumer, by means of a purchase invoice. If there is any change in the structure of the product or defect occurs due to negligence of the assembler/consumer in relation to the assembly and handling instruction, free technical assistance will not be provided.

1º

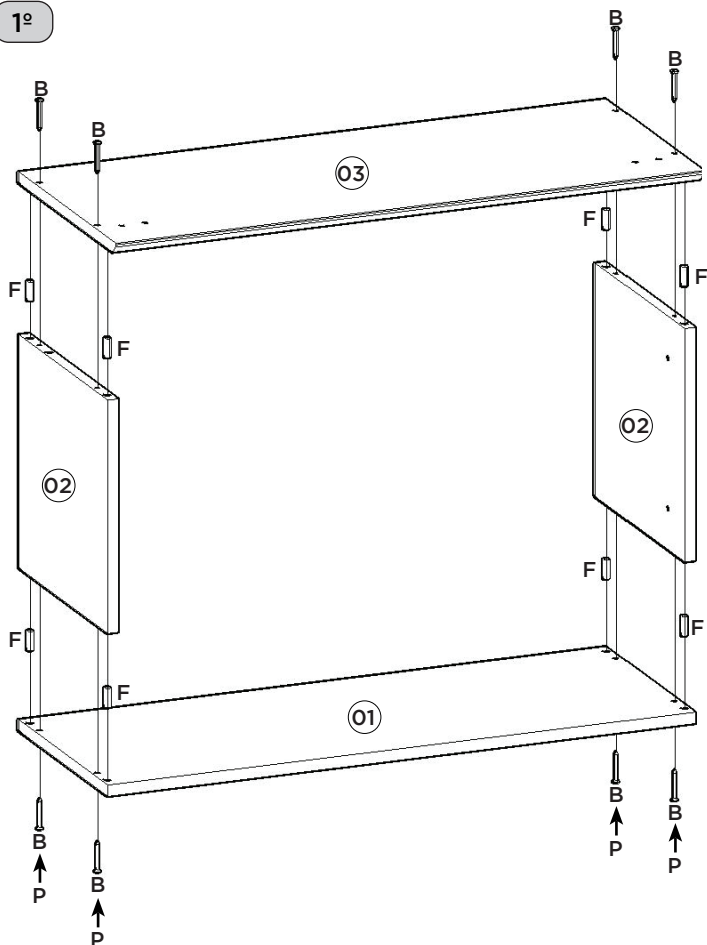

Utilizar o sachê de cola (O)  
em todas as cavilhas (F)  
do produto.

Con el pegamento sobre (O)  
en todos los pernos (F)  
producto.

Use the glue sachet (O) on all  
the pegs (F) of the product.

2º

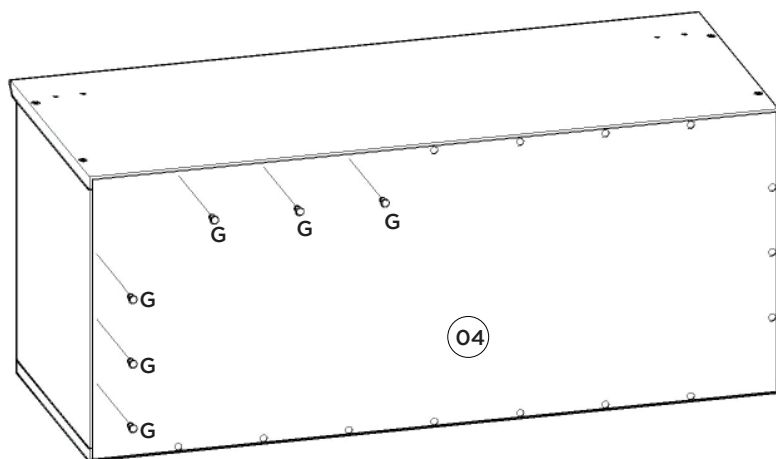

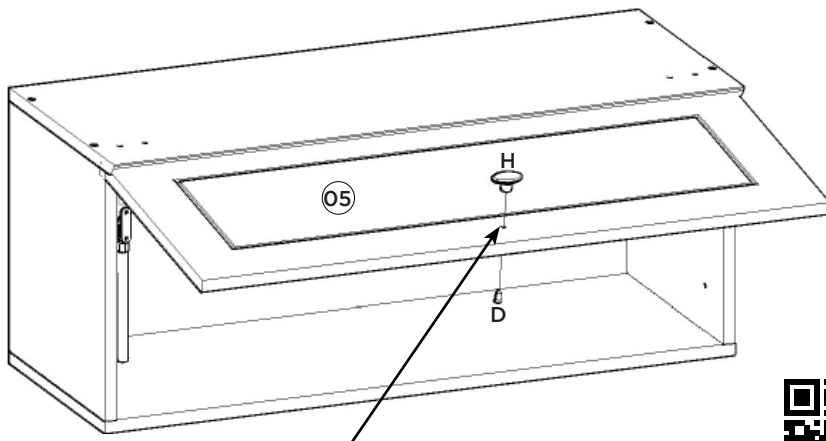

Para colocação do puxador, é necessário fazer a furação passante, com broca de 5mm.

Para colocar el mango, es necesario perforar con un taladro de 5 mm.

For placing the handle, it is necessary to drill through with a 5mm drill.



Vídeo: Instalar e regular Dobradiças

Vídeo: Instale y ajuste las bisagras

Vídeo: Install and adjust hinges

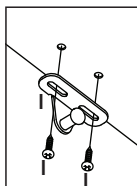
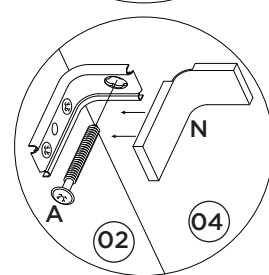
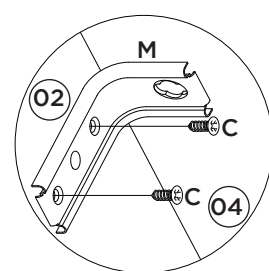
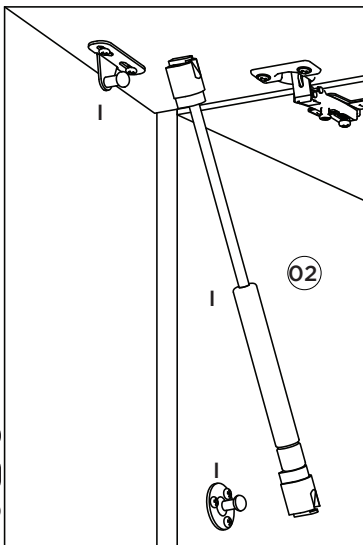
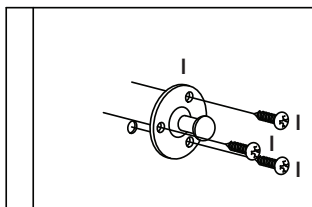
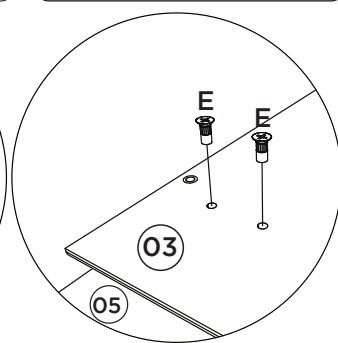
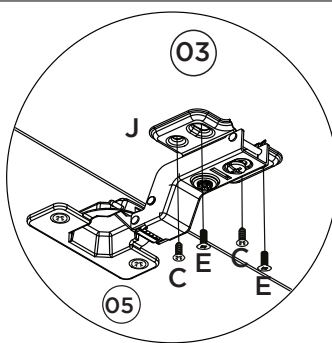
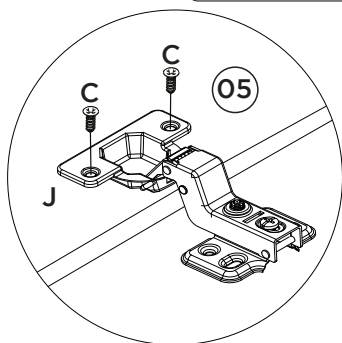

Vídeo: Dicas para instalar o Kit Pistão à Gás













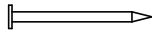

Vídeo: Consejos para instalar el kit de pistón de gas

Vídeo: Tips for installing the Gas Piston Kit

## Lista de Peças | Lista de piezas | List of parts

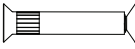
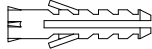
Item	Caixa Caja Box	Qty Ctd Qty	Descrição   Descripción   Description	Medidas (mm)   Dimensions (mm)   Size (measurements) (mm)
01	1/1	01	Base   Base   Base	800x295x15
02	1/1	02	Lateral Direita Esquerda   Lateral Derecha Izquierda   Right Side Left	307x295x15
03	1/1	01	Tampo   Tapa   Top	800x322x15
04	1/1	01	Fundo   Fondo   Bottom	793x331x3
05	1/1	01	Porta Basculante   Puerta Basculante   Basculating Door	796x315x15

## Ferragens | Herrajes | Hardware

<b>A</b>  Parafuso 5,0x50mm FLA. Tornillo 5,0x50mm FLA. Screw 5,0x50mm FLA.	02x	<b>B</b>  Parafuso 3,5x40mm CHT. Tornillo 3,5x40mm CHT. Screw 3,5x40mm CHT.	08x	<b>C</b>  Parafuso 4,0x14mm CHT. Tornillo 4,0x14mm CHT. Screw 4,0x14mm CHT.	12x	<b>D</b>  Parafuso M4x20mm CHT. ZB Tornillo M4x20mm CHT. ZB Screw M4x20mm CHT. ZB	01x	<b>E</b>  Parafuso União 15mm Tornillo Unión 15mm Union Screw 15mm	04x
<b>F</b>  Cavilha 8x25mm Cinta 8x25mm Dowel 8x25mm	08x	<b>G</b>  Prego 10x10mm Clavo 10x10mm Nail 10x10mm	20x	<b>H</b>  Puxador Pontual PZ14 Oval Tirador Puntual PZ14 Oval PZ14 Oval Point Knob	01x	<b>I</b>  Kit Pistão a Gás 60N Kit Pistón a Gas 60N 60N Gas Piston Kit	01x	<b>J</b>  Dobr. 35mm POP Super Alta Amort. + Calço Fixo Bisagra súper alta POP de 35mm con amortiguación + cuña fija 35mm POP Super High Hinge with Damping + Fixed Shim	02x
<b>K</b>  Parafuso União 30mm Tornillo Unión 30mm Union Screw 30mm	04x	<b>L</b>  Bucha plástica 8mm Bucha de plástico 8mm 8mm plastic bushing	02x	<b>M</b>  Suporte de fixação Soporte de fijación Mounting bracket	02x	<b>N</b>  Proteção para cantoneira Ángulo de protección Protection angle	02x	<b>O</b>  Sachê de cola Bolsa de pegamento Glue bag	01x
<b>P</b>  Adesivo tampa parafuso 10mm Adhesivo tapón de tornillo 10mm Bolt cover adhesive 10mm	08x								



O parafuso (K) deve ser usada somente quando este módulo for acoplado a outro módulo componível Henn.



El tornillo (K) se debe utilizar sólo cuando el módulo está conectado a otro módulo componible Henn.



The screw (K) should be used only when this module is attached to another Henn modular module.

## RECOMENDAÇÃO

Para fixar o móvel na parede usar o suporte de fixação (M), o parafuso 4,0x14mm CHT (C), a Bucha 8mm (L) e o parafuso 5,0x50mm FLA (A).

## RECOMENDACIÓN

Para conectar el móvil a la pared con el soporte (M), tornillo 4,0x14mm CHT (C), el casquillo de 8 mm (L) y el 5,0 x50mm tornillo FLA (A).

## RECOMMENDATION

To fix the furniture to the wall use the fixing bracket (M), the 4.0x14mm CHT (C) screw, the 8mm bushing (L) and the 5.0x50mm FLA screw (A).

**HENN**Ind. e Com. de Móveis Henn  
Mondai - SC - Brasil

☎ +55 49 3674.3500

📧 @moveishenn  
www.henn.com.br**INSTRUÇÕES DE MONTAGEM**INSTRUCCIONES DE MONTAJE  
ASSEMBLY INSTRUCTIONS**Tampo para Balcão 1200mm | Tablero para Balcón 1200mm | Counter Top 1200mm**

- C905-23 Duna
- C905-33 Nero
- C905-90 Grafite HP
- C905-94 Rústico
- C905-114 Calcare

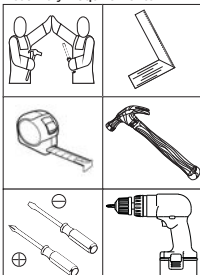
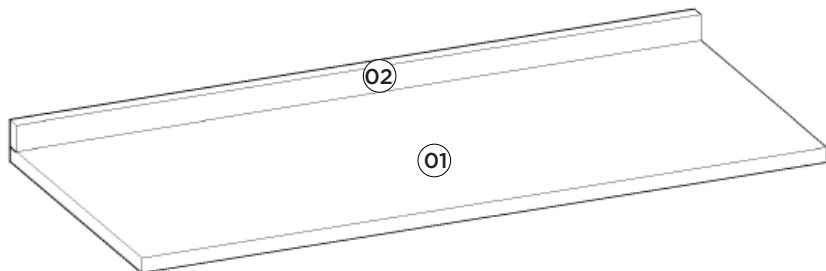
Requisitos para montagem  
Requisitor para la montaje  
Assembly RequirementsImagens meramente ilustrativas  
Imágenes meramente ilustrativas  
Images for illustration only**AVISO**

Para limpeza de seu móvel, use uma flanela seca ou umedecida, e não utilize produtos químicos que possam danificar seu produto.

**SISTEMA DE MONTAGEM**

O sistema de montagem dos produtos, funciona de acordo com a ordem crescente dos números indicados no desenho. Ex: 01, 02, 03, 04... até a conclusão da montagem.

**ADVERTENCIA**

Para limpieza de su móvil, use una franela seca o húmeda, y no utilice productos químicos que puedan dañar su producto.

**Lista de Peças | Lista de piezas | List of parts**

Item	Caixa Caja Box	Qtd Ctd Qty	Descrição   Descripción   Description	Medidas (mm)   Dimensions (mm)   Size (measure- ments) (mm)
01	1/1	01	Tampo   Tapa   Top	1200x533x25
02	1/1	01	Rodatampo   Rodatampo   Rodatampo	1200x45x25

**SISTEMA DE MONTAJE**

El sistema de montaje de los productos funciona de acuerdo con el orden creciente de los números indicados en el dibujo. Ej.: 01, 02, 03, 04... hasta la conclusión del montaje.

**NOTICE**

To clean your furniture, use a dry or wet cloth, and do not use chemicals that may damage your product.

**Ferragens | Herrajes | Hardware**

<b>A</b>	04x	<b>B</b>	12x	<b>C</b>	06x
Parafuso 4,5x50mm CHT. Tornillo 4,5x50mm CHT. Screw 4,5x50mm CHT.		Parafuso 3,5x14mm FLA. Tornillo 3,5x14mm FLA. Screw 3,5x14mm FLA.		Cantoneira plástica Cantонера plástica Plastic angle brackets	

**ASSEMBLY SYSTEM**

The products' assembly system works according to the increasing order of the indicated numbers. For example: 01, 02, 03, 04 ... to the end of the assembly.

⚠ Estas ferragens constam no Pacote do respectivo Balcão.  
Estos herrajes constan en el Paquete del respectivo Balcón.  
These hardware are included in the Package of the respective Counter.

Esse tampo é opcional e é vendido separadamente

Esta vez es opcional y se vende por separado

This top is optional and is sold separately

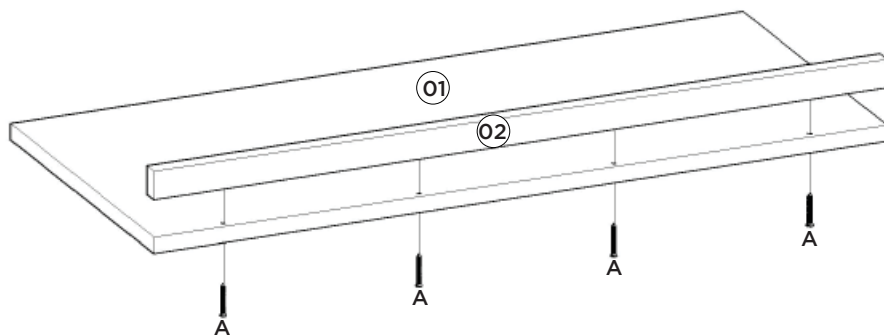

Exemplo de como fixar o Tampo no produto.

Ejemplo de la fijación de la tapa sobre el producto.

Example of fixing the lid on the product.

