

07 Montagem da Gaveta

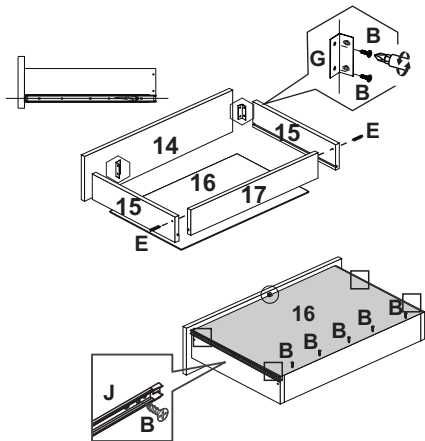

10 Colocação da Gaveta

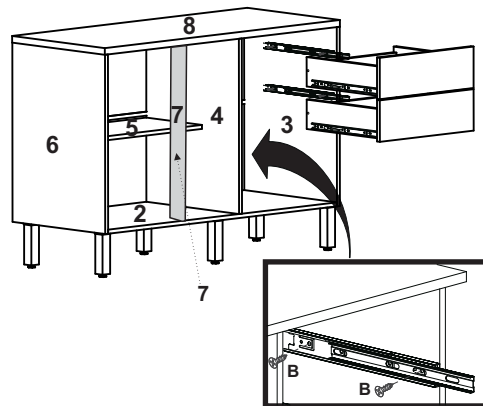

09 Montagem das Dobradiças

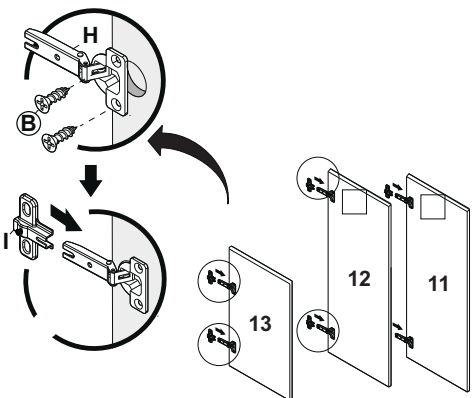

10 Montagem das Portas

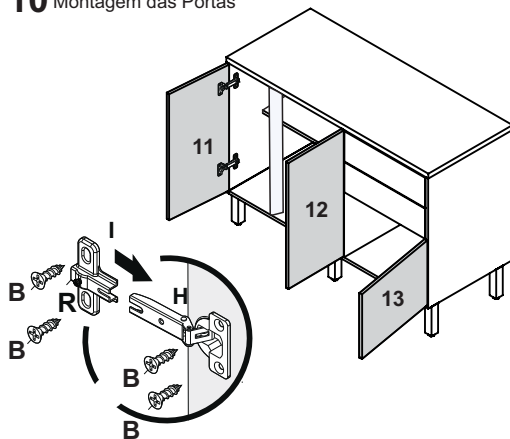

11 Fixação dos puxadores

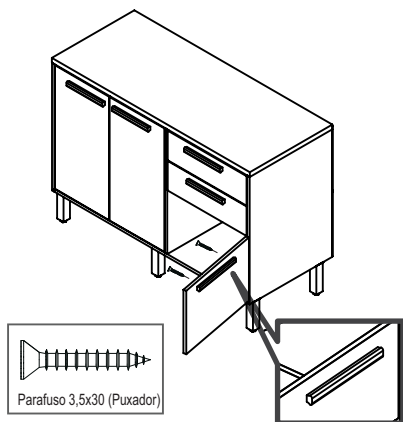

12 Fixação da régua do tampo.

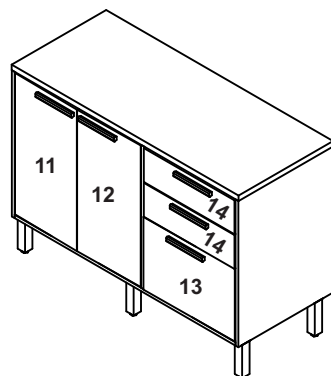

BALCÃO ANNE

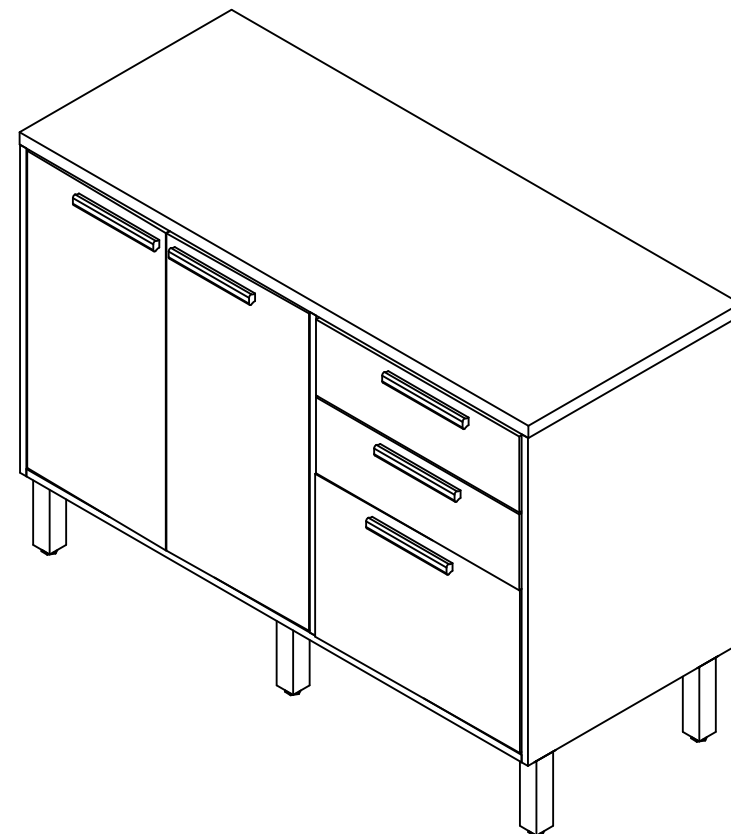

Atualizado em: 25/03/2024 Ao solicitar assistência, informe o número da peça e a letra do acessório









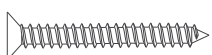
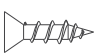

Rua Projetada S/N - Biarro Belo Horizonte
Rodeiro - MG - CEP 36510-000

(32) 3577-3900

LISTA DE PEÇAS

CÓD	SEQ	DESCRIÇÃO	COMP.	LARG.	ESP.	QNTD
19815	2	Base	1203	432	12	1
19817	3	Lateral Direita	670	432	12	1
19819	4	Divisao	670	432	12	1
19828	5	Prateleira	794	360	12	1
19818	6	Lateral Esquerda	670	432	12	1
19820	7	Divisao Estreita	670	72	12	1
19816	8	Tampo	1203	450	15	1
19827	9	Costa	1195	345	3	1
19827	10	Costa	1195	345	3	1
19821	11	Porta Dir./Esq.	675	399	15	1
19821	12	Porta Dir./Esq.	675	399 <td 15	1	
19825	13	Porta pequena	380	370	15	1
19822	14	Frete Gaveta	380	148	15	2
19823	15	Lateral Gaveta	300	90	12	4
19824	16	Traseiro Gaveta	324	80	12	2
19826	17	Fundo Gaveta	345	305	3	2

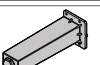
KIT DE FERRAGENS / COD. 19829

A	 X15 Parafuso 3,5X35 (Estrutura)	B	 X90 Parafuso 3,5x12	C	 X15 Cavilha 6x30
P	 X10 Parafuso 3,5 X 25 Flangeado (Puxador)	E	 X05 Parafuso 5x40 (Pés)	F	 X50 Prego 10x10
G	 X11 Conector	H	 X06 Dobradiça 26mm	I	 X06 Calço Dobradiça 12mm
J	 X02 Corrediça telescópica 350 mm / COD. 467	K(01)	 X05 Pés Regulável COD. 19497	L	 X05 Puxador Madeira COD. 19556

Medidas em mm

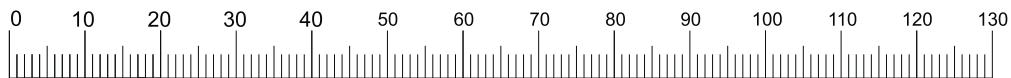

Atualizado em:
08/08/2023

Ao solicitar assistência, informe o número da peça e a letra do acessório

01 Fixação dos Pés

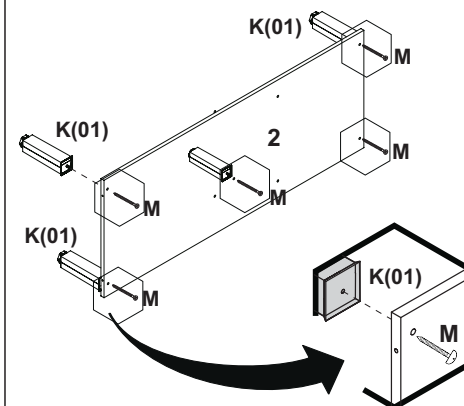

02 Fixação das Laterais Na Base

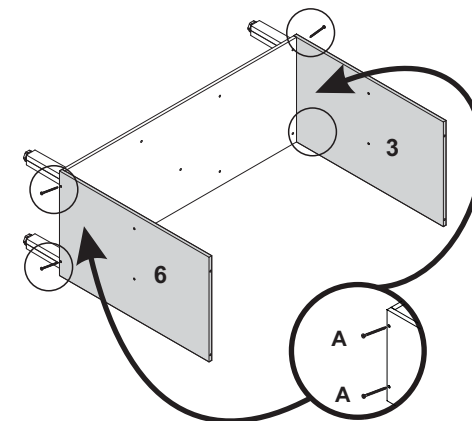

03 Fixação da Divisão Na Base

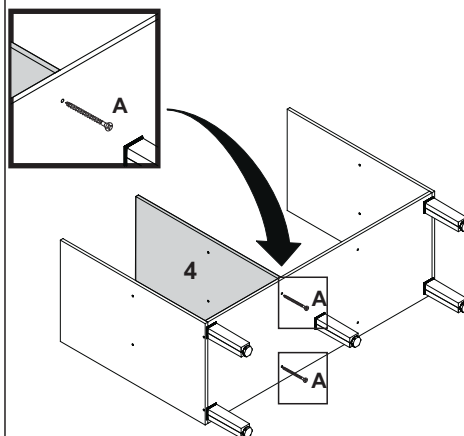

04 Fixação da Prateleira

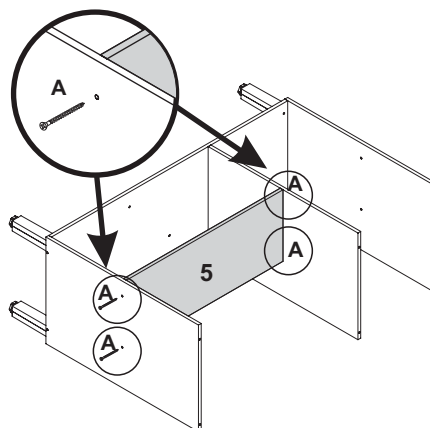

05 Fixação do Tampo

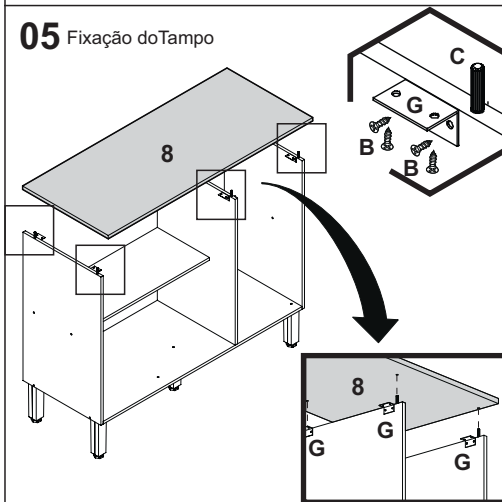

06 Montagem das Costas!

