

Quiditá

Essência da qualidade

Móveis Quiditá
Bento Gonçalves - RS
Rodovia BR-470 KM 202 - Cep 95710-000
Fone: 0xx (54) 3458-1001
www.quiditamoveis.com.br

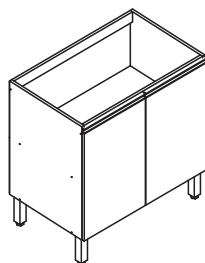

8005

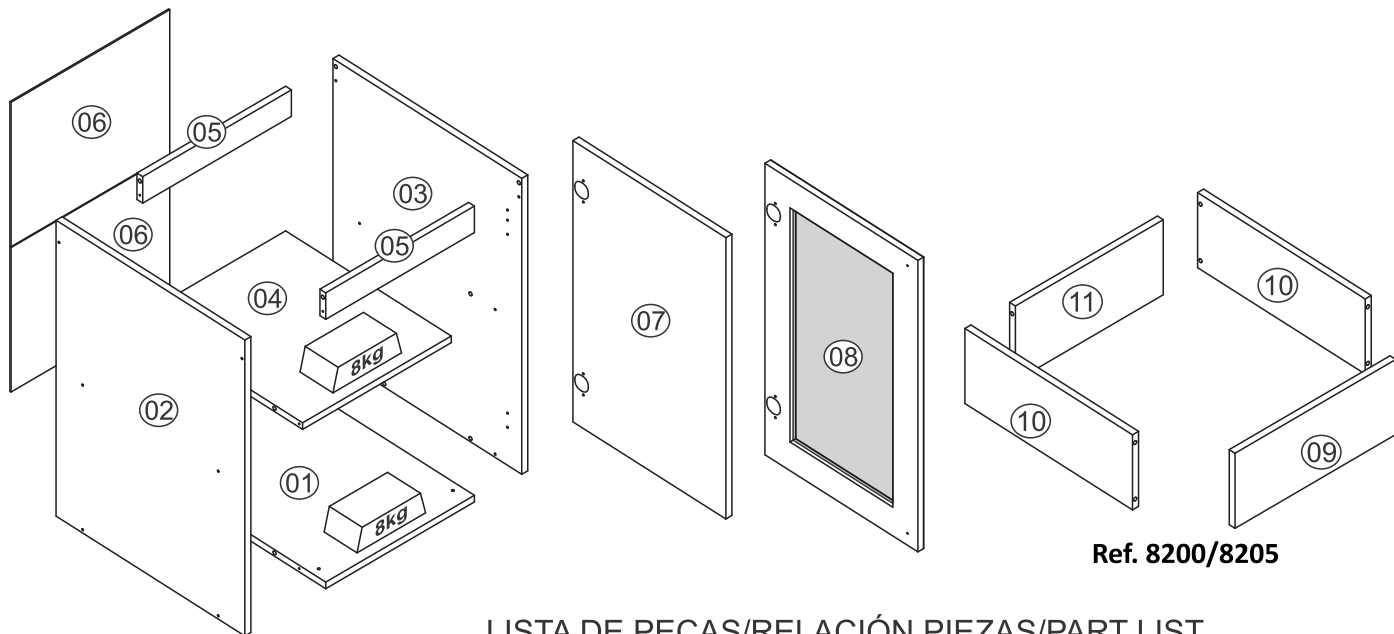

Ref. 8200/8205

LISTA DE PEÇAS/RELACIÓN PIEZAS/PART LIST

Ref. 8000/8200

Nº	Código Code	Descrição/Descripción/Description	Dimensão (mm) Dimensiones (mm) Measures (mm)	Qtde. Cantidad Quantity
01	800001	Base/Base/Base	370 x 490 x 15	01
02	800003	Lateral esquerda/Left side/L teral izquierda	670 x 490 x 15	01
03	800002	Lateral direita/Right side/Lateral derecha	670 x 490 x 15	01
04	800004	Prateleira/Repisa/Shelf	370 x 430 x 15	01
05	800005	Travessa/Traverse/Travessaño	370 x 60 x 15	02
06	800006	Costa/Revés/Back	395 x 327 x 3	01
07	800008	Porta/Puerta/Door (Ref. 8000)	637 x 397 x 15	01
08	Q01306	Porta/Puerta/Door (Ref. 8200)	660 x 397 x 15	01

Ref. 8005/8205

Nº	Código Code	Descrição/Descripción/Description	Dimensão (mm) Dimensiones (mm) Measures (mm)	Qtde. Cantidad Quantity
01	800501	Base/Base/Base	770 x 490 x 15	01
02	800003	Lateral esquerda/Left side/L teral izquierda	670 x 490 x 15	01
03	800002	Lateral direita/Right side/Lateral derecha	670 x 490 x 15	01
04	800502	Prateleira/Repisa/Shelf	770 x 430 x 15	01
05	800503	Travessa/Traverse/Travessaño	770 x 60 x 15	02
06	800504	Costa/Revés/Back	395 x 327 x 3	01
07	800008	Porta/Puerta/Door (Ref. 8005)	637 x 397 x 15	02
08	Q01306	Porta/Puerta/Door (Ref. 8205)	660x 397 x 15	02

Ref. 8205

09	810502	Rodapé frontal/Front baseboard/Zócalo delantero	400 x 170 x 15	01
10	810501	Rodapé lateral/Side baseboard/Zócalo lateral	435 x 170 x 15	02
11	810503	Rodapé traseiro/Back baseboard/Zócalo de atras	368 x 170 x 15	01

FERRAMENTAS NECESSÁRIAS
HERRAMIENTAS NECESARIAS
NECESSARY TOOLS/

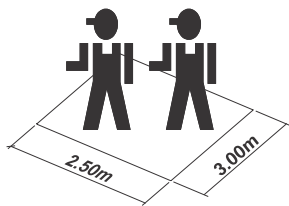

60 min

**2 Ref. 8000/8005
Ref. 8200/8205**

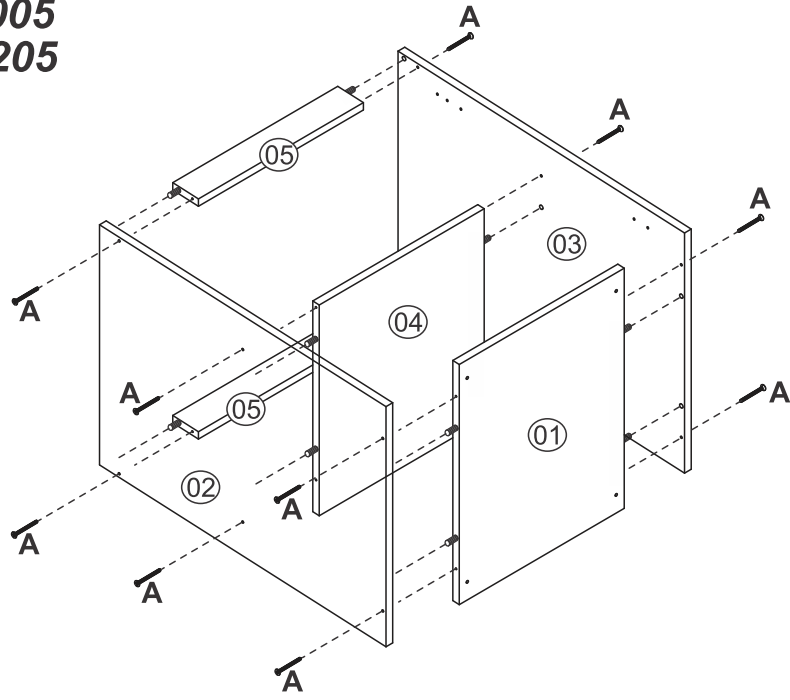

3 - Ref. 8000/8005

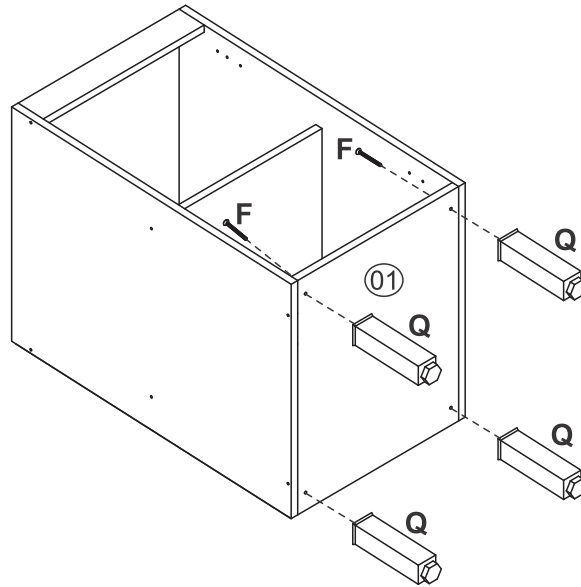

3 - Ref. 8200/8205

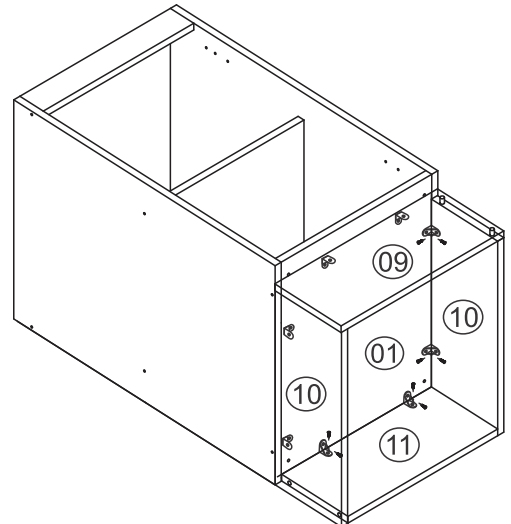
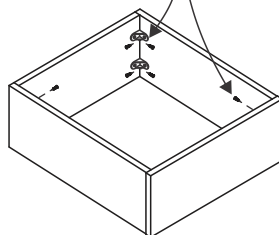
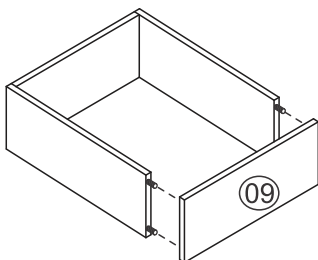
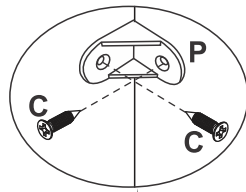
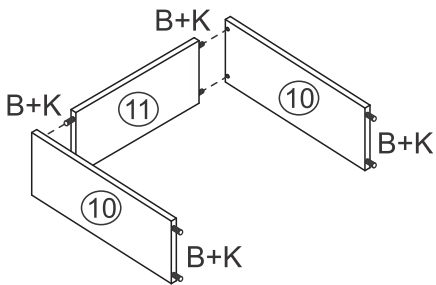

4

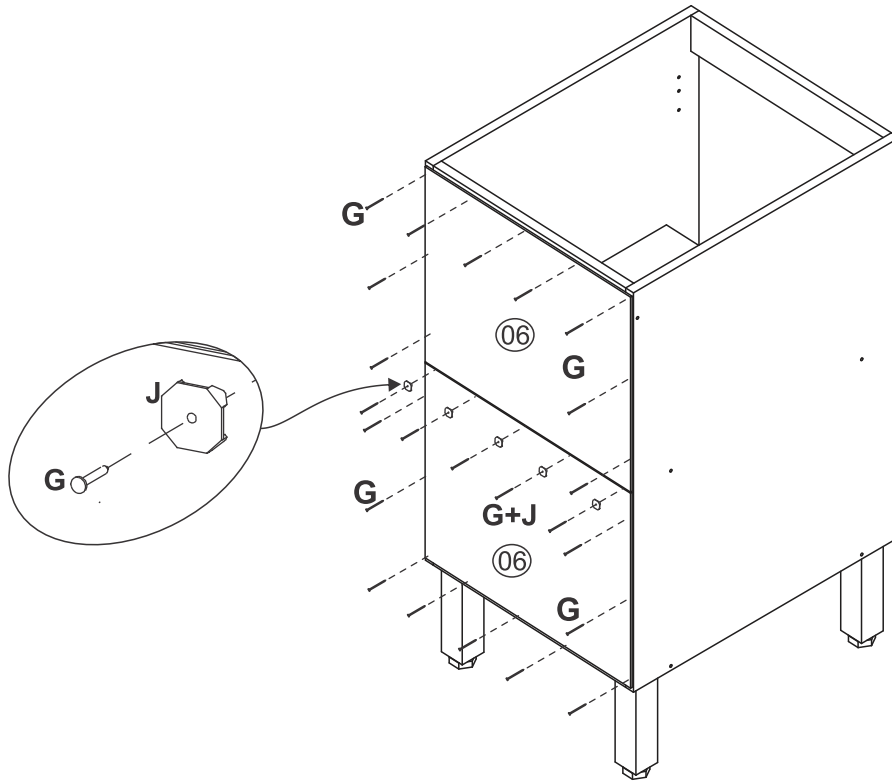

5 Fixação na parede - opcional
Fixing in the wall - optional
Fijación en pared - opcional

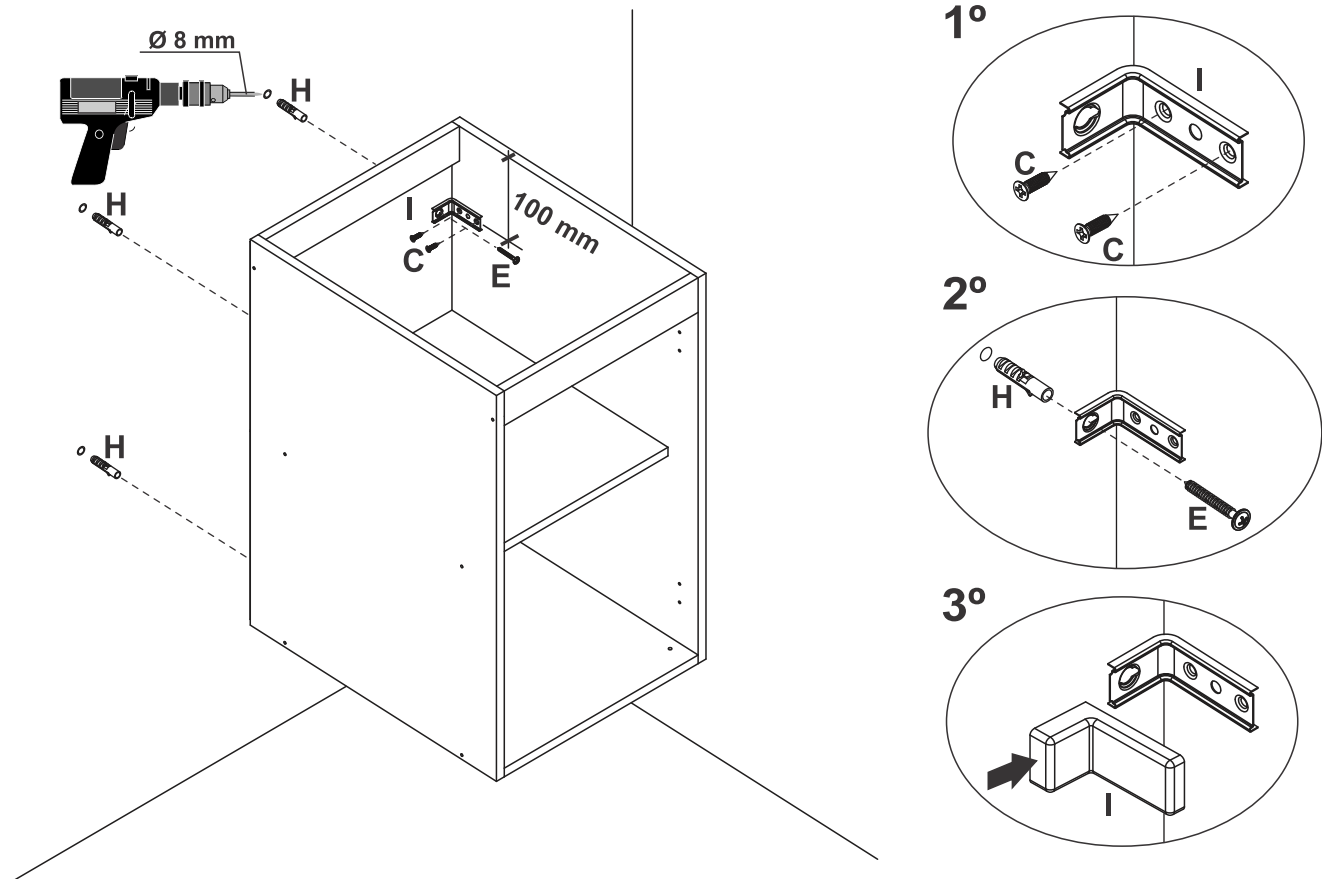

6 Posição de fixação do calço da dobradiça
Hinge base fixing position
Posición de fijación de la base de la bisagra

Ref. 8000/8005

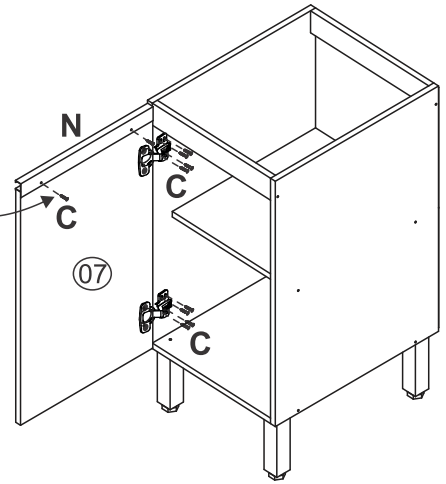
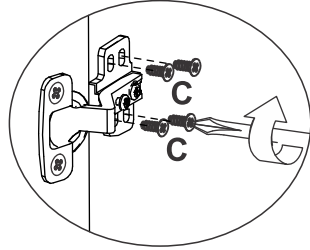
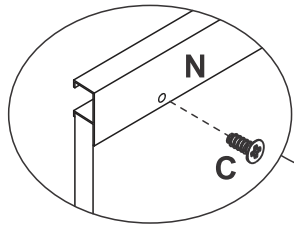
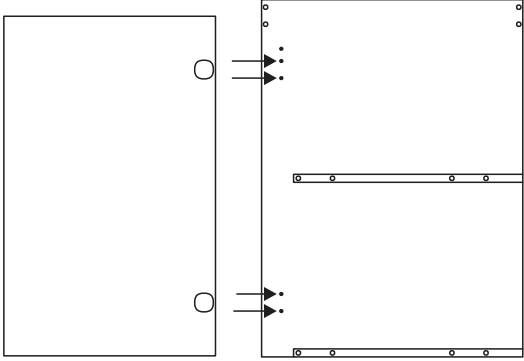

Ref. 8200/8205

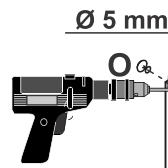
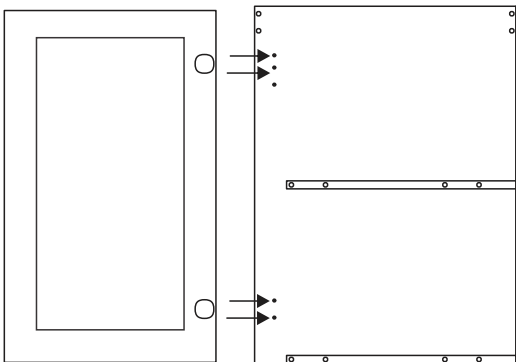

Ref. 8200/8205
A porta pode ser
direita ou esquerda.
The door can be
right or left.
La puerta puede ser
derecha o izquierda.

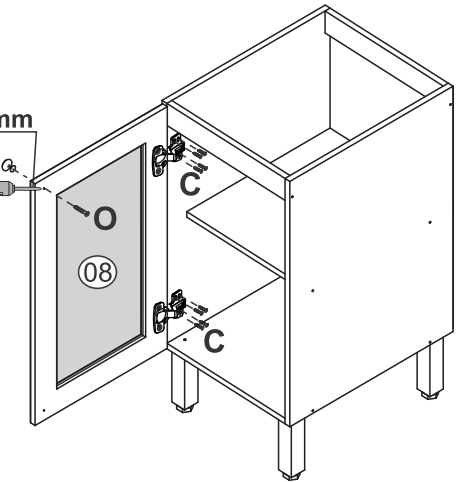

7

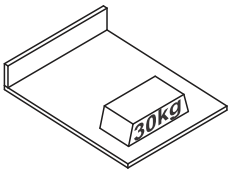



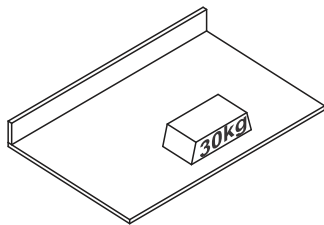

Ref. 8080



Ref. 8085

Tampos vendidos separadamente
Tops sold separately
Las tapas se venden por separado

FERRAGENS/HERRAJES/HARDWARE

		8080	8085
A	  Ø4,0x40mm	02	03
B	  Ø3,5x14mm	08	16
P		04	08



Ø3,0x25mm
União de módulos
Unión de módulos
Union of modules

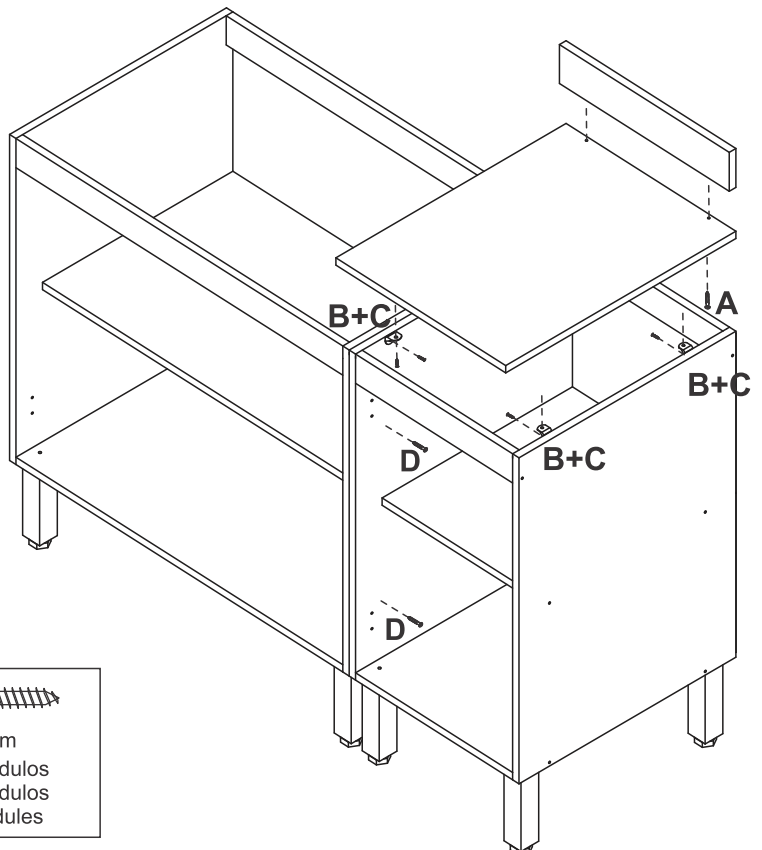

Quiditá

Essência da qualidade

Móveis Quiditá
Bento Gonçalves - RS
Rodovia BR-470 KM 202 - Cep 95710-000
Fone: 0xx (54) 3458-1001
www.quiditamoveis.com.br

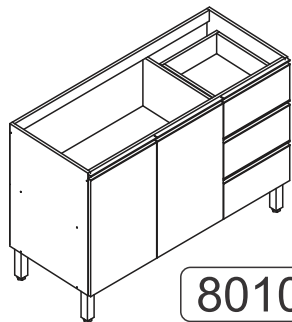

8010

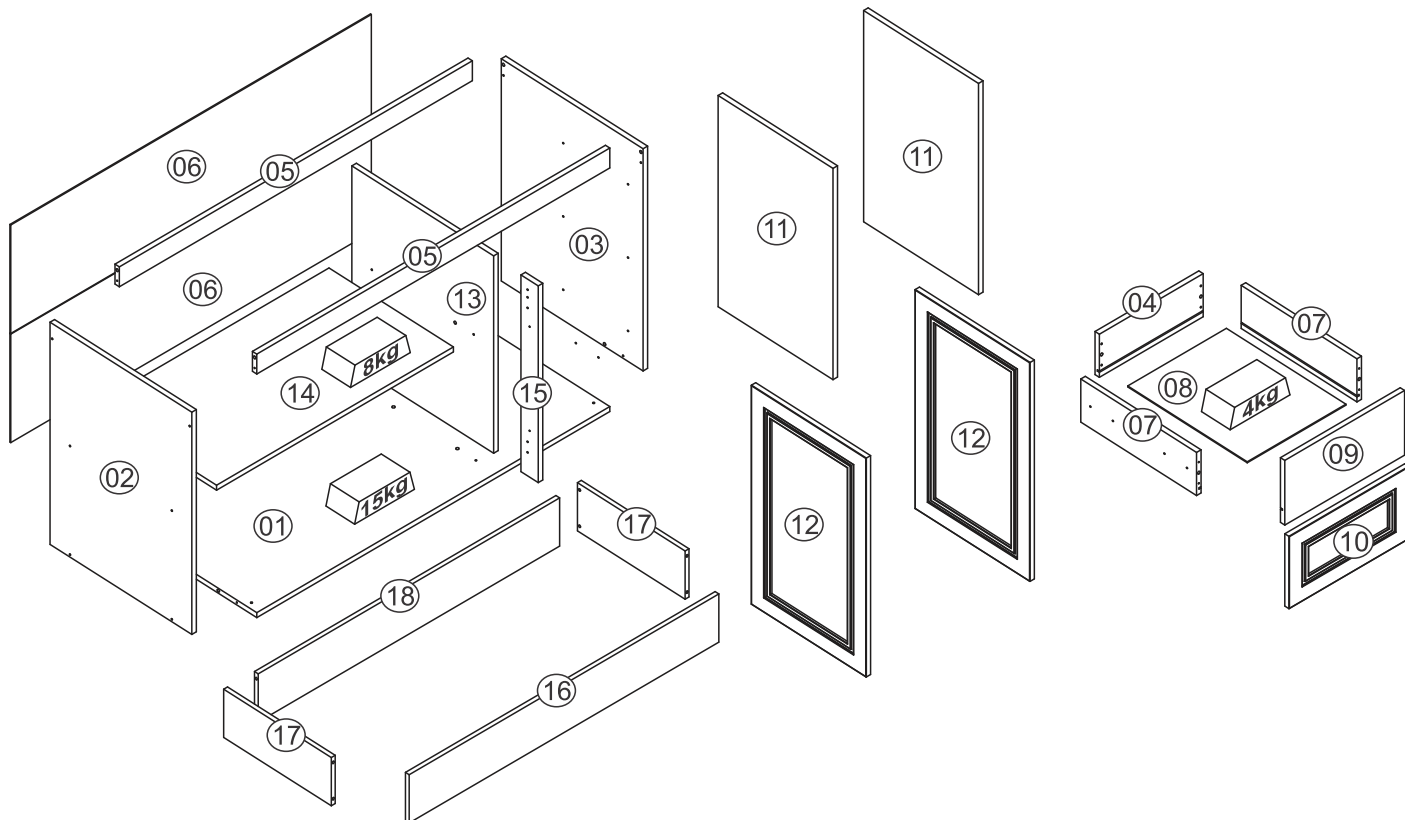

FERRAMENTAS NECESSÁRIAS
HERRAMIENTAS NECESARIAS
NECESSARY TOOLS/

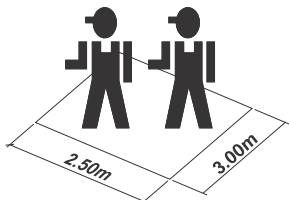
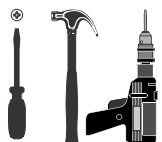

60 min











LISTA DE PEÇAS/RELACIÓN PIEZAS/PART LIST



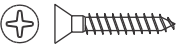
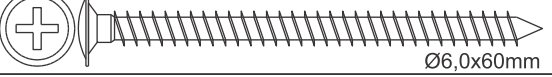

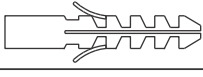

Nº	Código Code	Descrição/Descripción/Description	Dimensão (mm) Dimensiones (mm) Measures (mm)	Qtde. Cantidad Quantity
01	801001	Base/Base/Base	1170 x 490 x 15	01
02	800003	Lateral esquerda/Left side/L teral izquierda	670 x 490 x 15	01
03	801002	Lateral direita/Right side/Lateral derecha	670 x 490 x 15	01
04	801008	Costa gaveta/Drawer back/Revés cajón	344 x 130x 15	03
05	801004	Travessa/Traverse/Travessaño	1770 x 60 x 15	02
06	801010	Costa/Revés/Back	1195 x 327 x 3	02
07	801007	Lateral gaveta/Drawer side/Lateral cajón	400 x 130 x 15	06
08	801011	Fundo gaveta/Drawer botom/Fondo cajón	413 x 327 x 3	03
09	801012	Frente gaveta/Drawer front/Frente cajón Ref. 8010	397 x 195 x 15	03
10	Q01307	Frente gaveta/Drawer front/Frente cajón Ref. 8210	218 x 397 x 15	03
11	800008	Porta/Door/Puerta Ref. 8010	637 x 397 x 15	02
12	Q01306	Porta/Door/Puerta Ref. 8210	660 x 397 x 15	02
13	801006	Divisão/Division/Divisória	595 x 490 x 15	01
14	801003	Prateleira/Shelf/Repisa	785 x 430 x 15	01
15	801005	Montante/Door traverse/Travessaño puerta	595 x 60 x 15	01

Ref. 8210



16	811501	Rodapé frontal/Front baseboard/Zócalo delantero	1200 x 170 x 15	01
17	810501	Rodapé lateral/Side baseboard/Zócalo lateral	435 x 170 x 15	02
18	811502	Rodapé traseiro/Back baseboard/Zócalo de atras	1168 x 170 x 15	01

FERRAGENS/HERRAJES/HARDWARE

A		$\varnothing 4,0 \times 40 \text{mm}$	26
B		Cavilha/Tarugo/Dowel $\varnothing 8 \times 30 \text{mm}$	26
C		$\varnothing 3,5 \times 14 \text{mm}$	98
D		$\varnothing 4,0 \times 25 \text{mm}$	04
E		$\varnothing 6,0 \times 60 \text{mm}$	04
F		$\varnothing 5,0 \times 50 \text{mm}$ Ref. 8010	05
G		Prego/Clavo/Nail 10x10	33
H		Bucha/Cojinete/Bush 8mm	04
I			04
J			14
K		Garra metálica/Pieza fijación revés/ Back claw 13x13	07

L		Sache cola/Pegamento/Glue	01
M			05
N		Puxador perfil/Tirador/Handle 397mm Ref. 8010	05
O		Puxador/Tirador/Handle Ref. 8210	05
P		Trilho telescópico/Trillo telescópico/Telescopic sliding 350mm	03
Q		Tapa furo/Tapa agujero/Hole sticker 12mm	16
R		Dobradiça/Bisagra Hinge 35mm	04

ROD1200

B		Cavilha/Tarugo/Dowel $\varnothing 8 \times 30 \text{mm}$	08
C		$\varnothing 3,5 \times 14 \text{mm}$	40
J			20

1 Separação corredeira/Separación corredera/Sliding separation

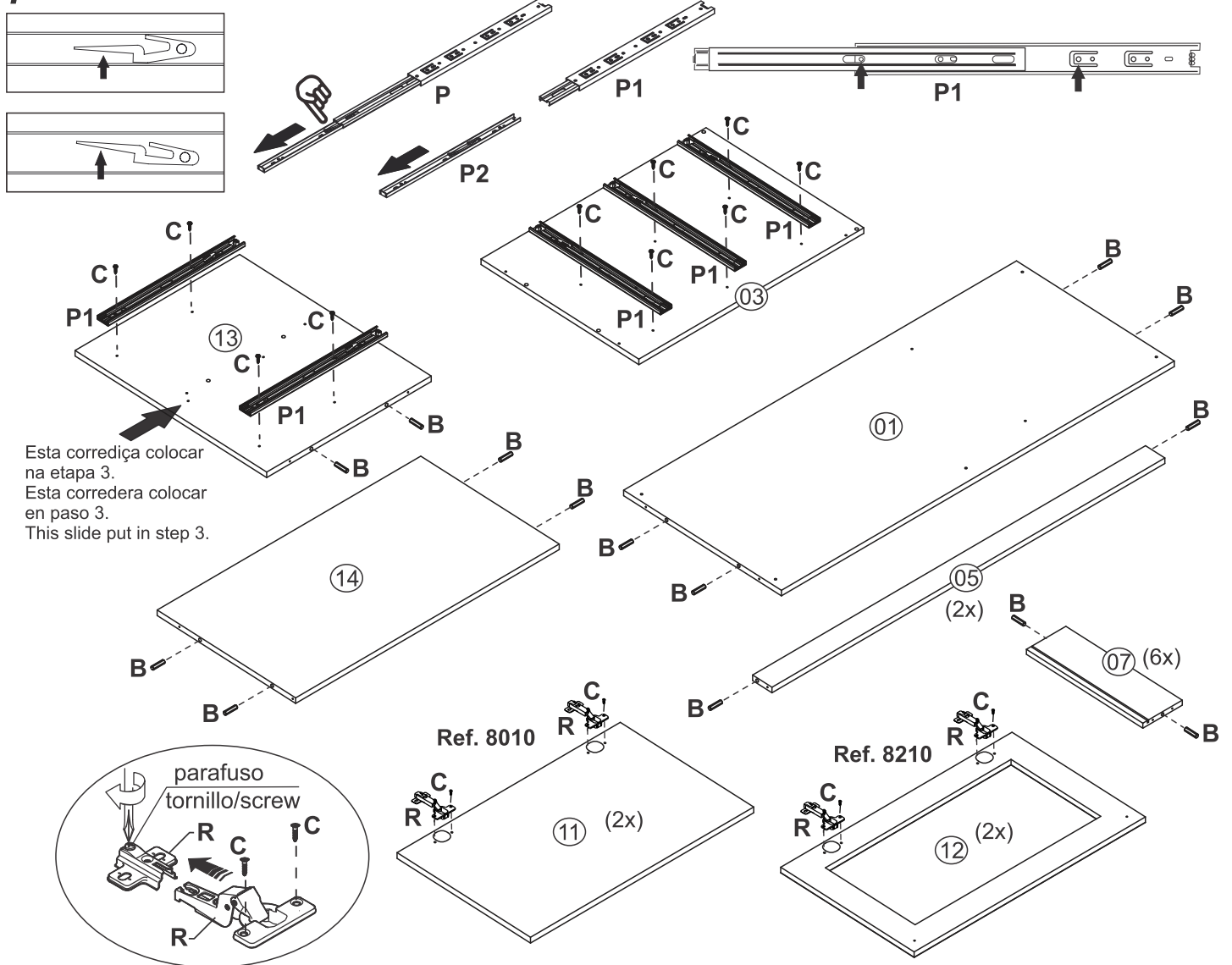

2

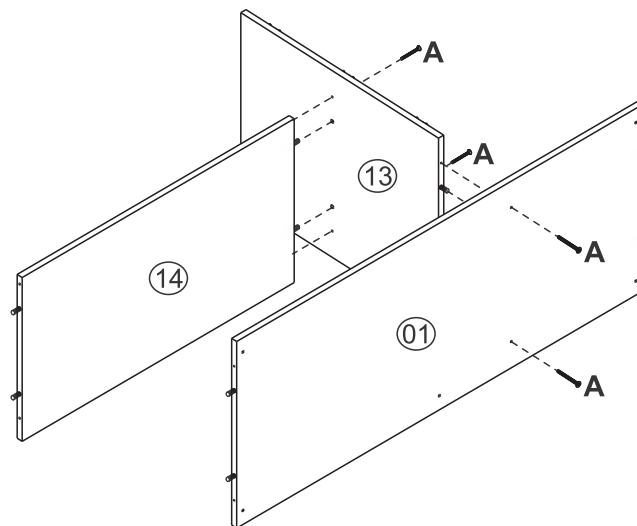

3

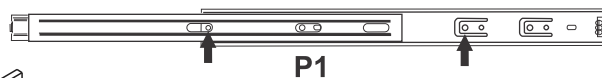
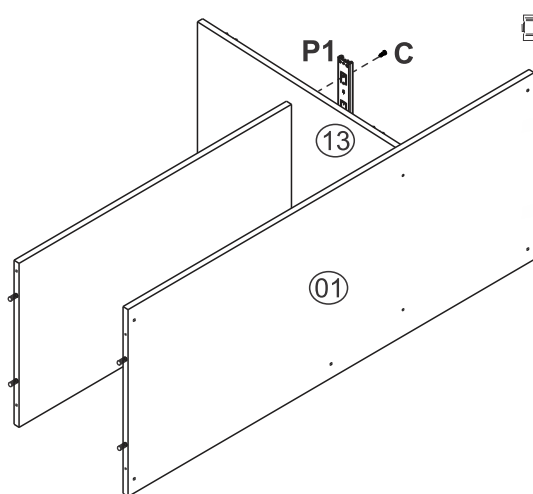

Fixar a corrediça central na divisão.
Fijar la corredera central en la divisoria.
Fix the central slide in the division.

4

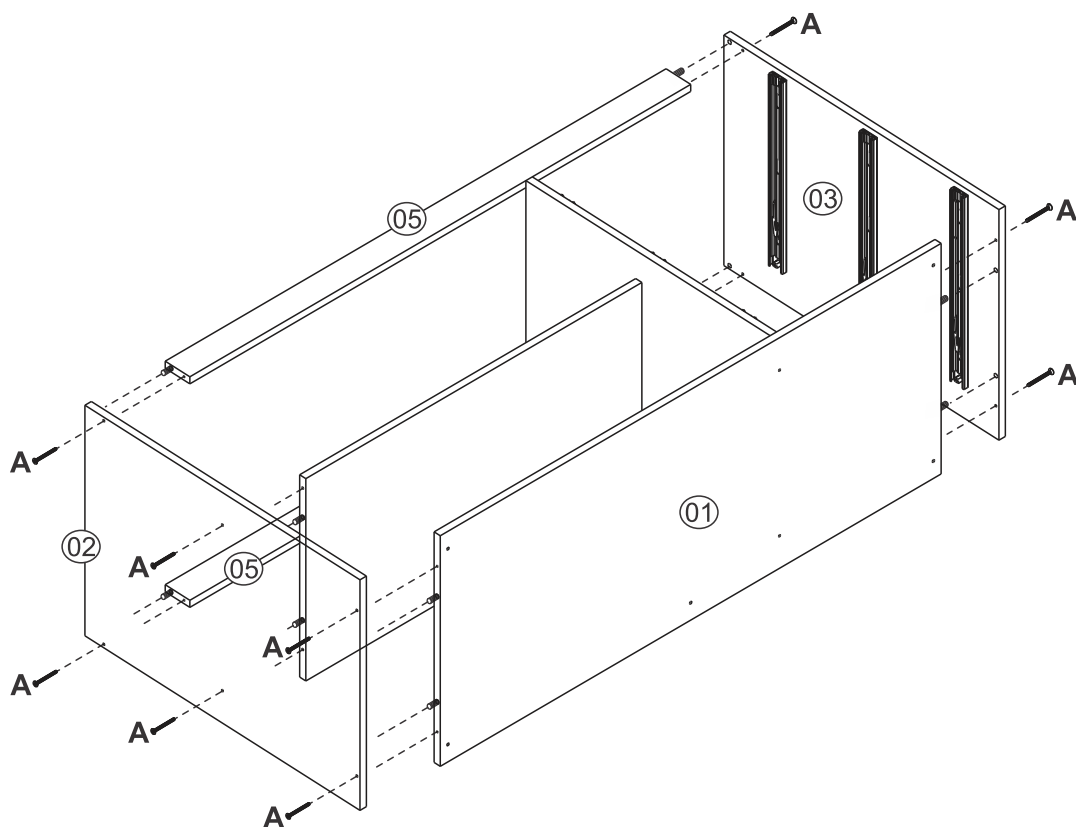

5 Ref. 8010

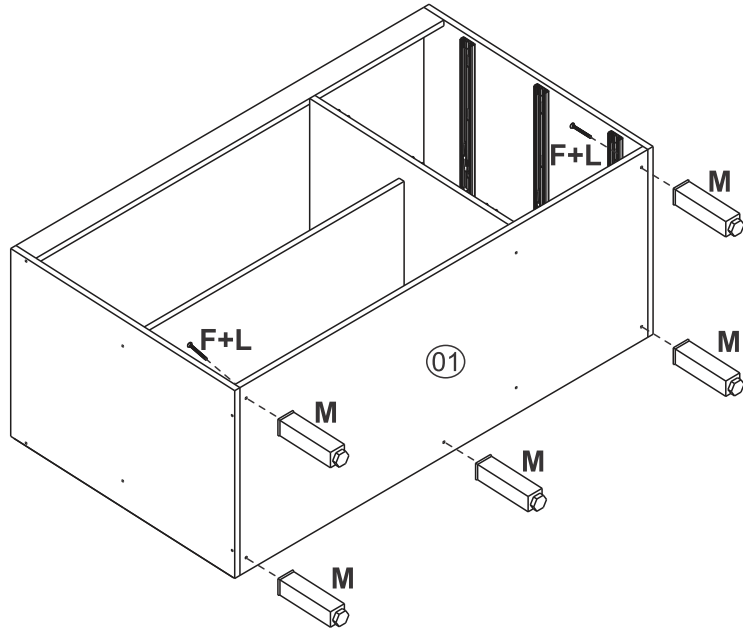

5 Ref. 8015

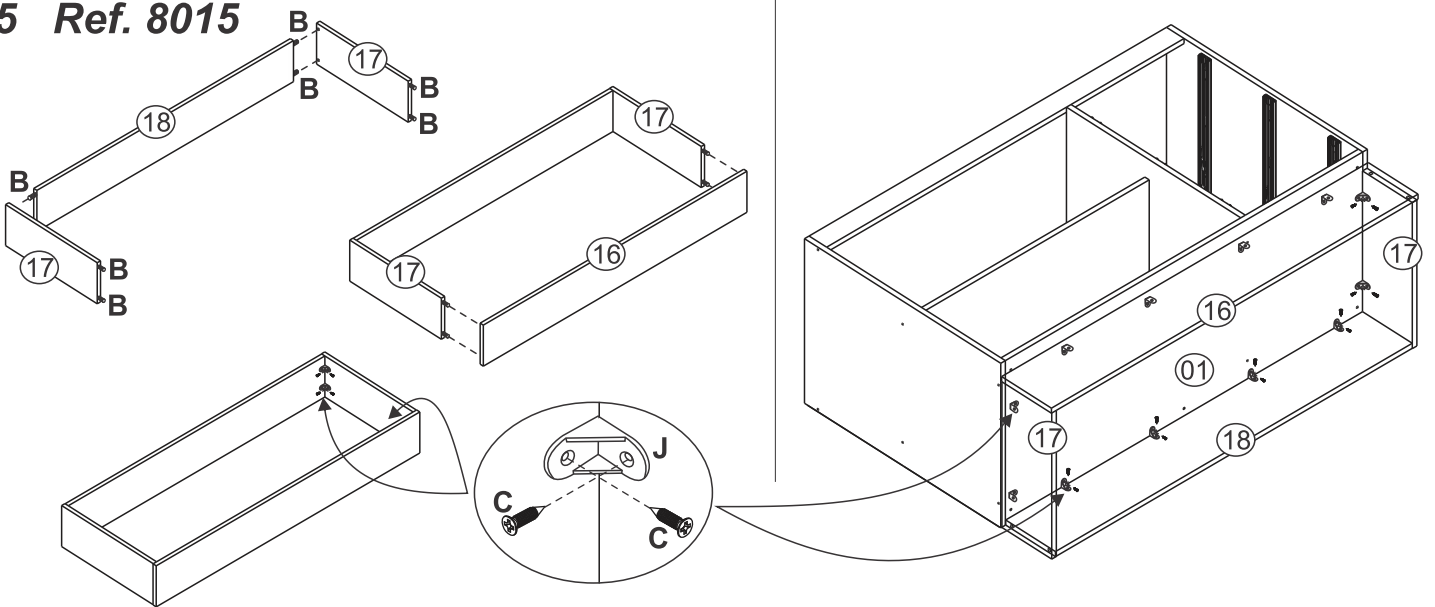

6 Ref. 8015/8215

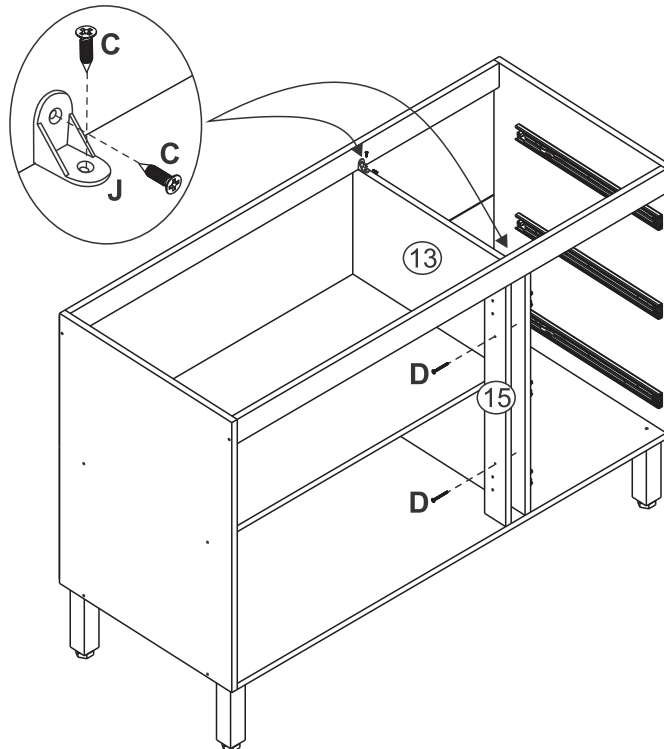

7

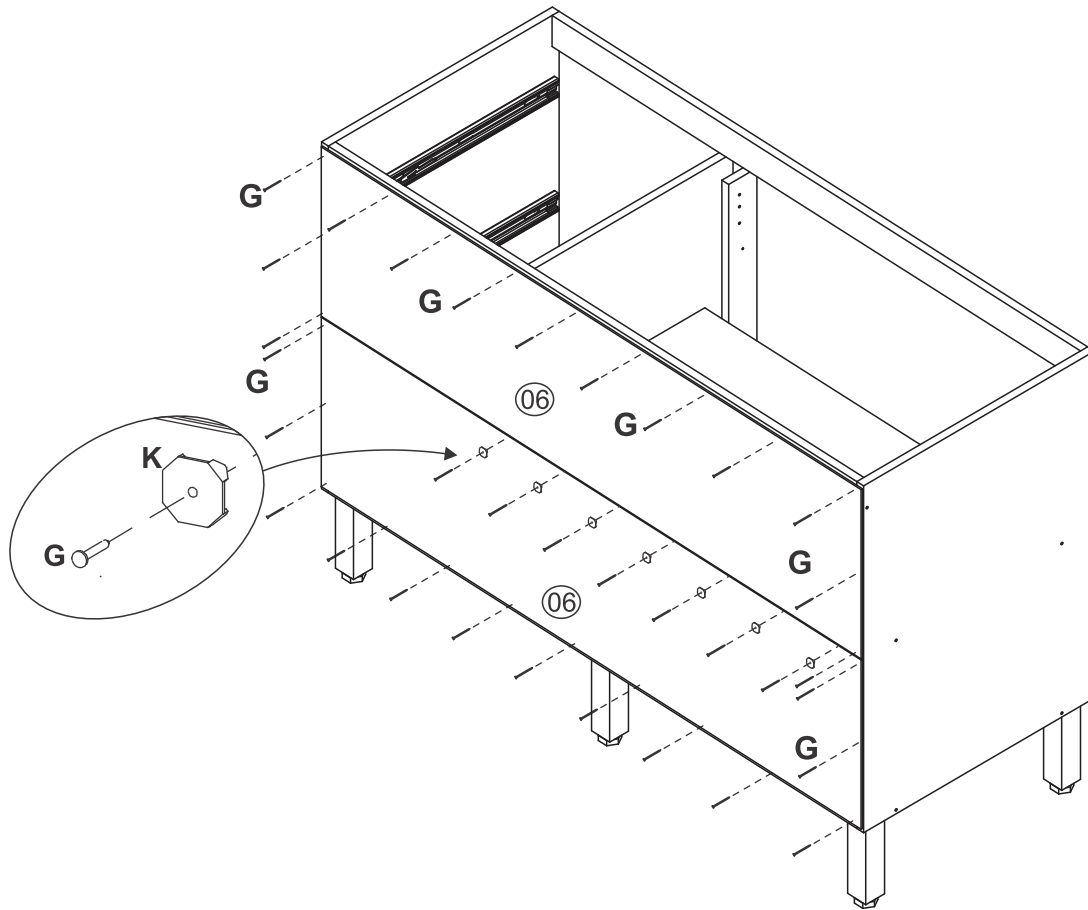

8 Fixação na parede - opcional
Fixing in the wall - optional
Fijación en pared - opcional

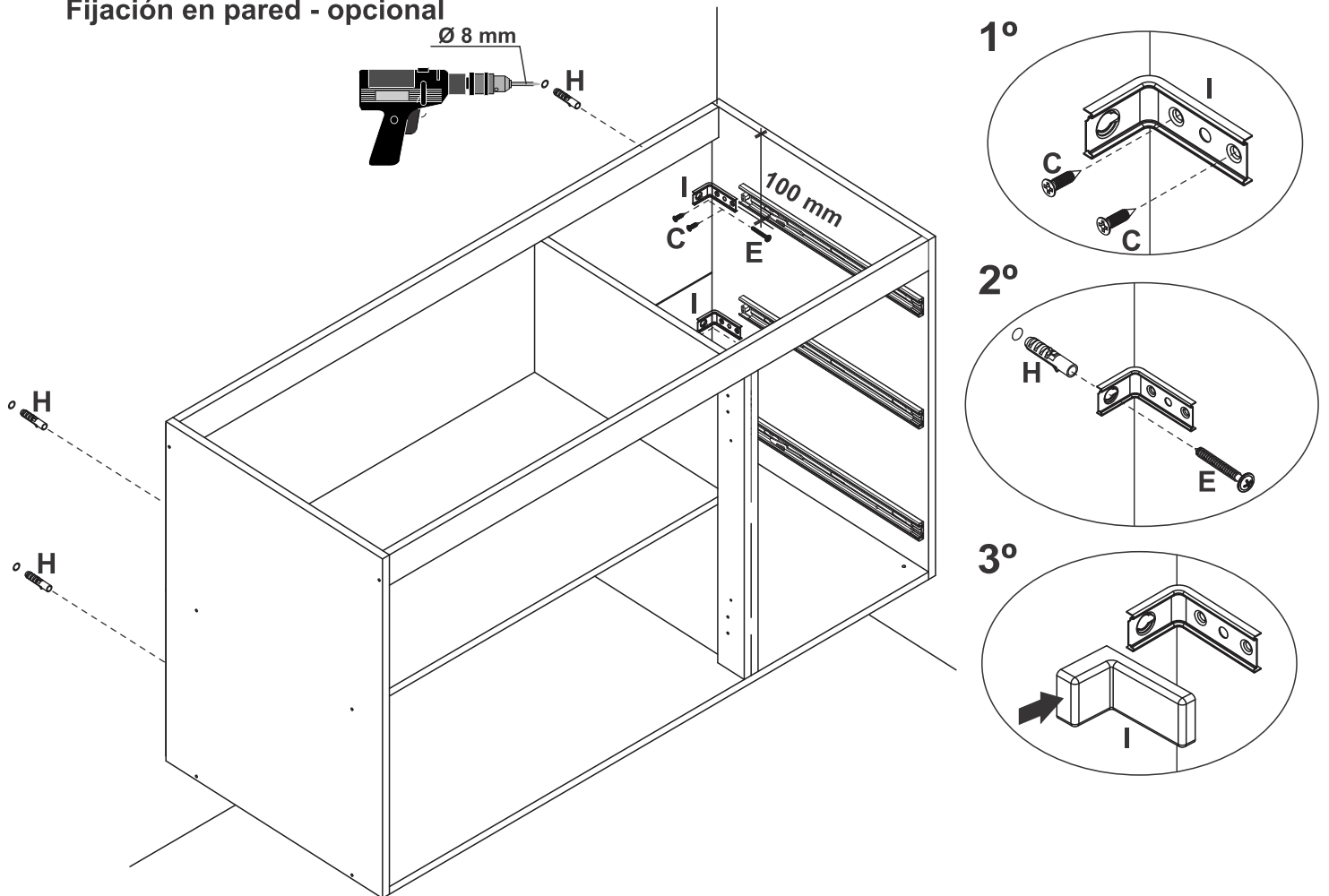

9

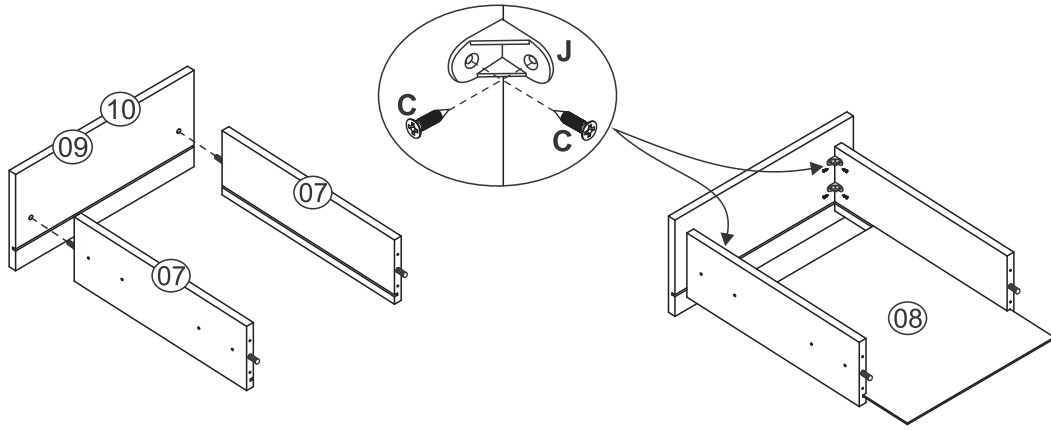

10

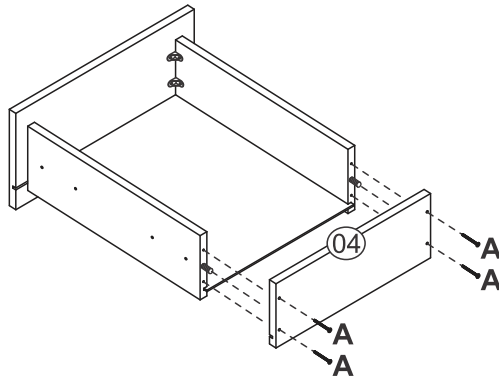

11

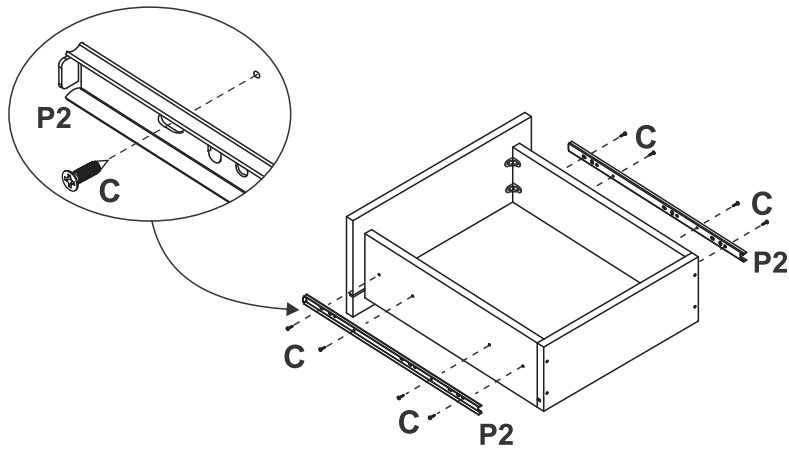

12

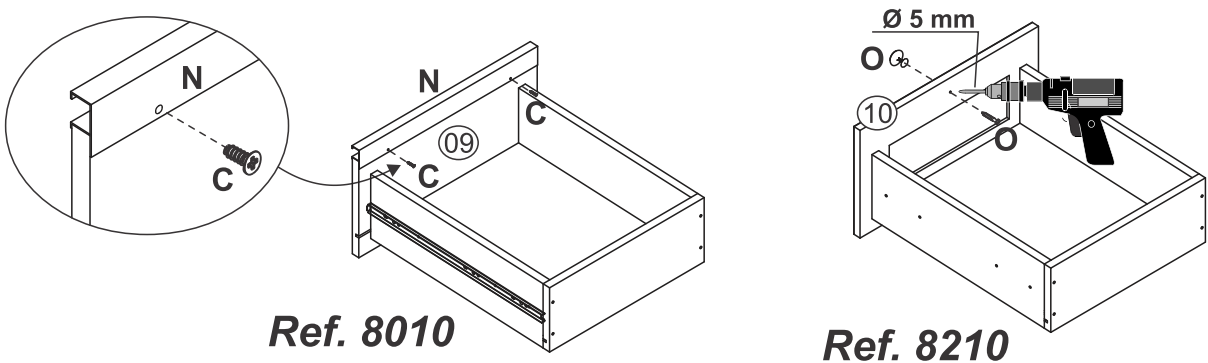

Ref. 8010

Ref. 8210

13 Posição de fixação do calço da dobradiça
Hinge base fixing position
Posición de fijación de la base de la bisagra

Ref. 8010

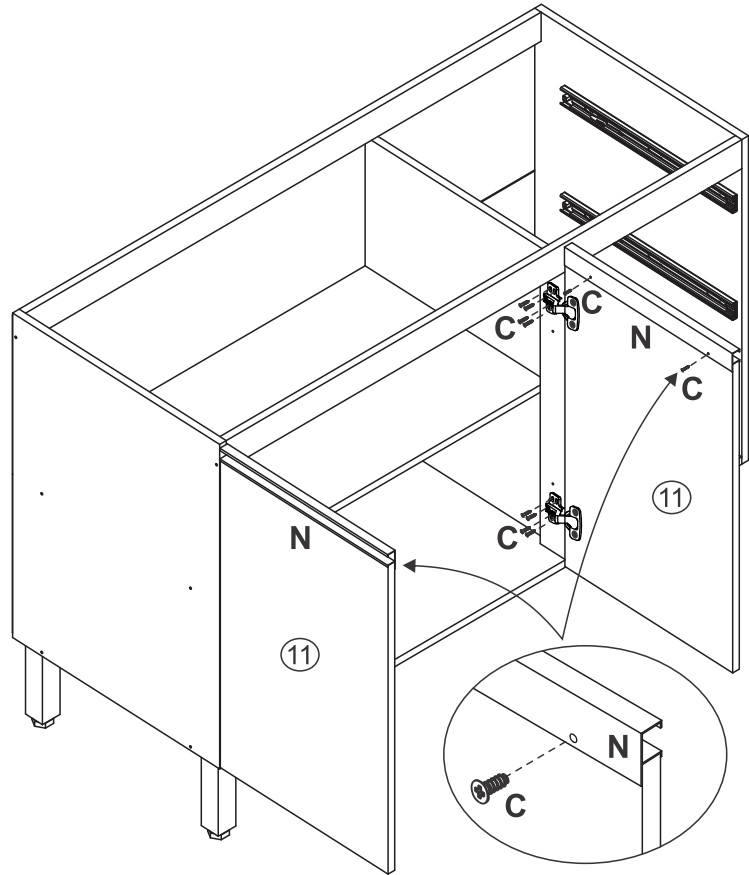
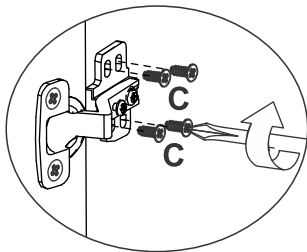
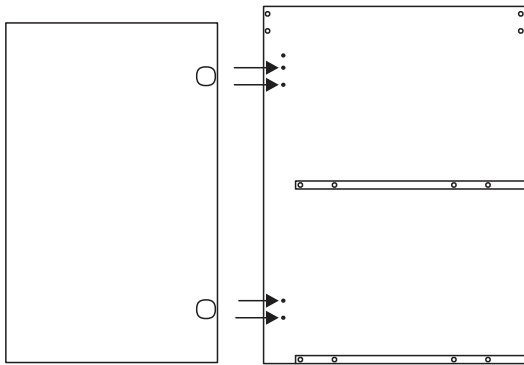

Ref. 8210

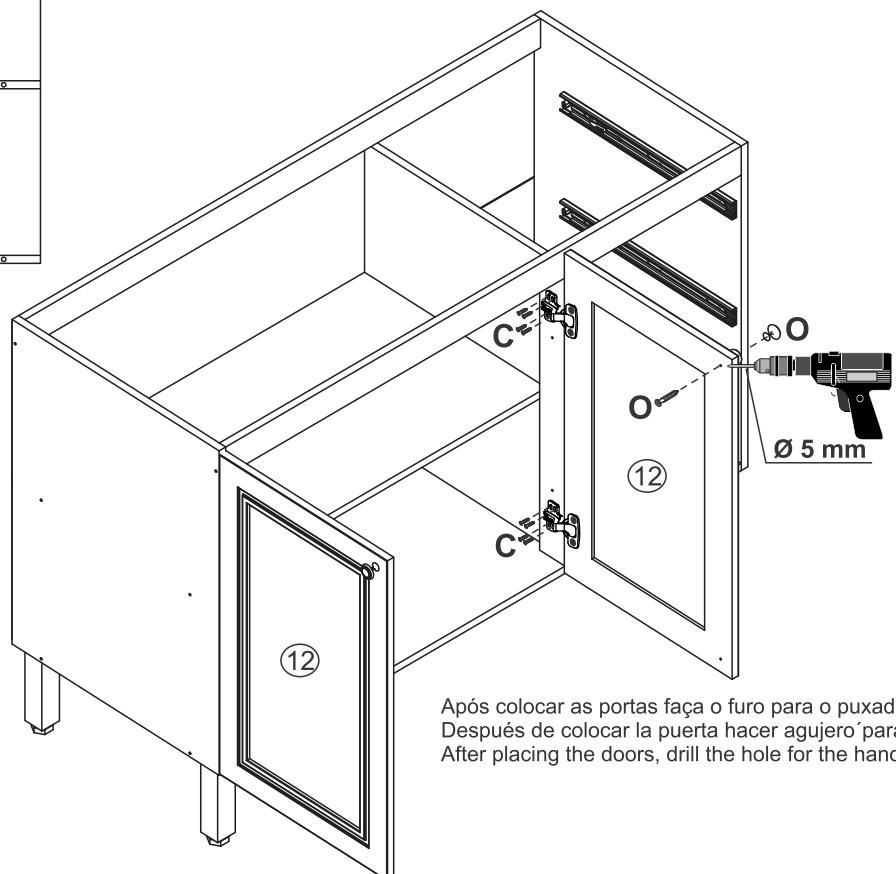
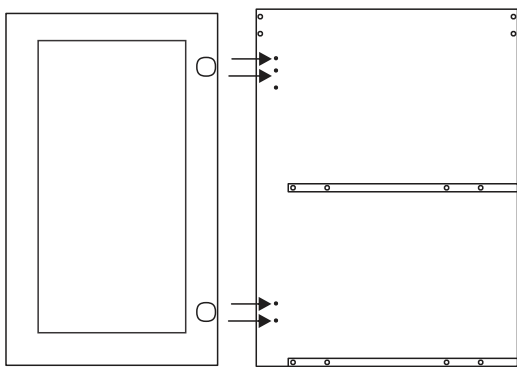

Após colocar as portas faça o furo para o puxador
Después de colocar la puerta hacer agujero para tornillo
After placing the doors, drill the hole for the handle



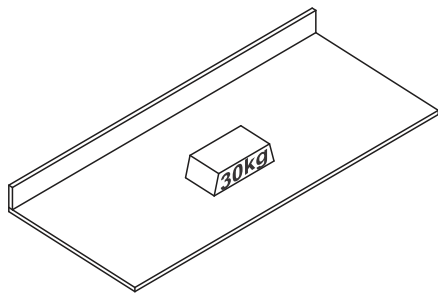

14

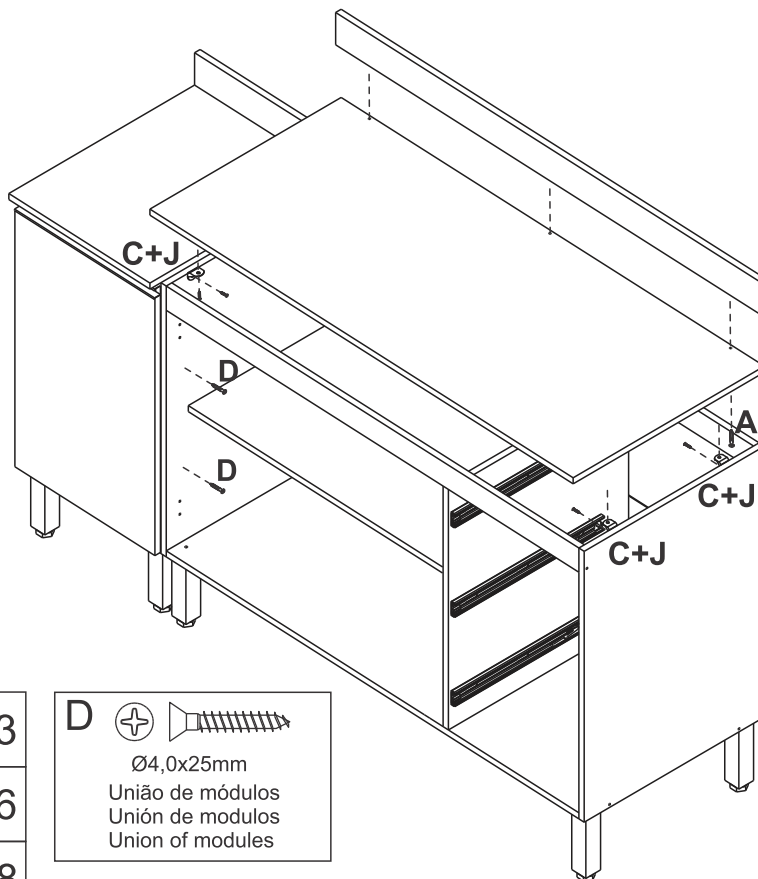



Tampo vendido separadamente
Top sold separately
La tapa se venden por separado



FERRAGENS/HERRAJES/HARDWARE

A	 	Ø4,0x40mm	03
C	 	Ø3,5x14mm	16
J			08

D	 	Ø4,0x25mm União de módulos Unión de módulos Union of modules
---	---	---

15

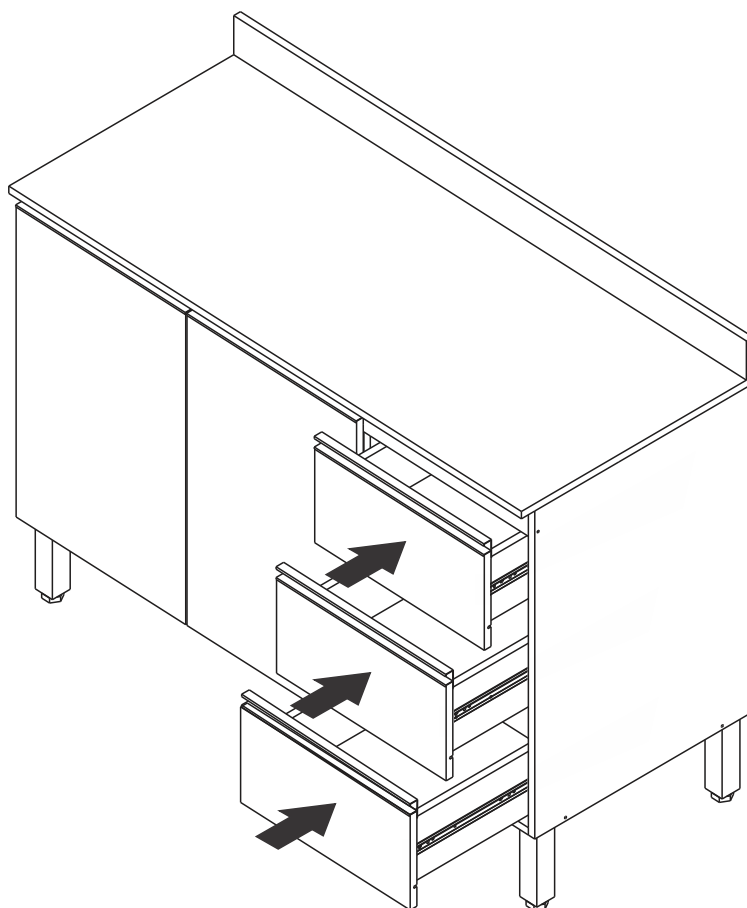

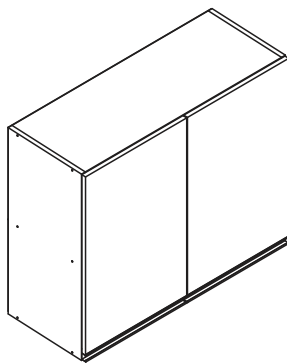

8025

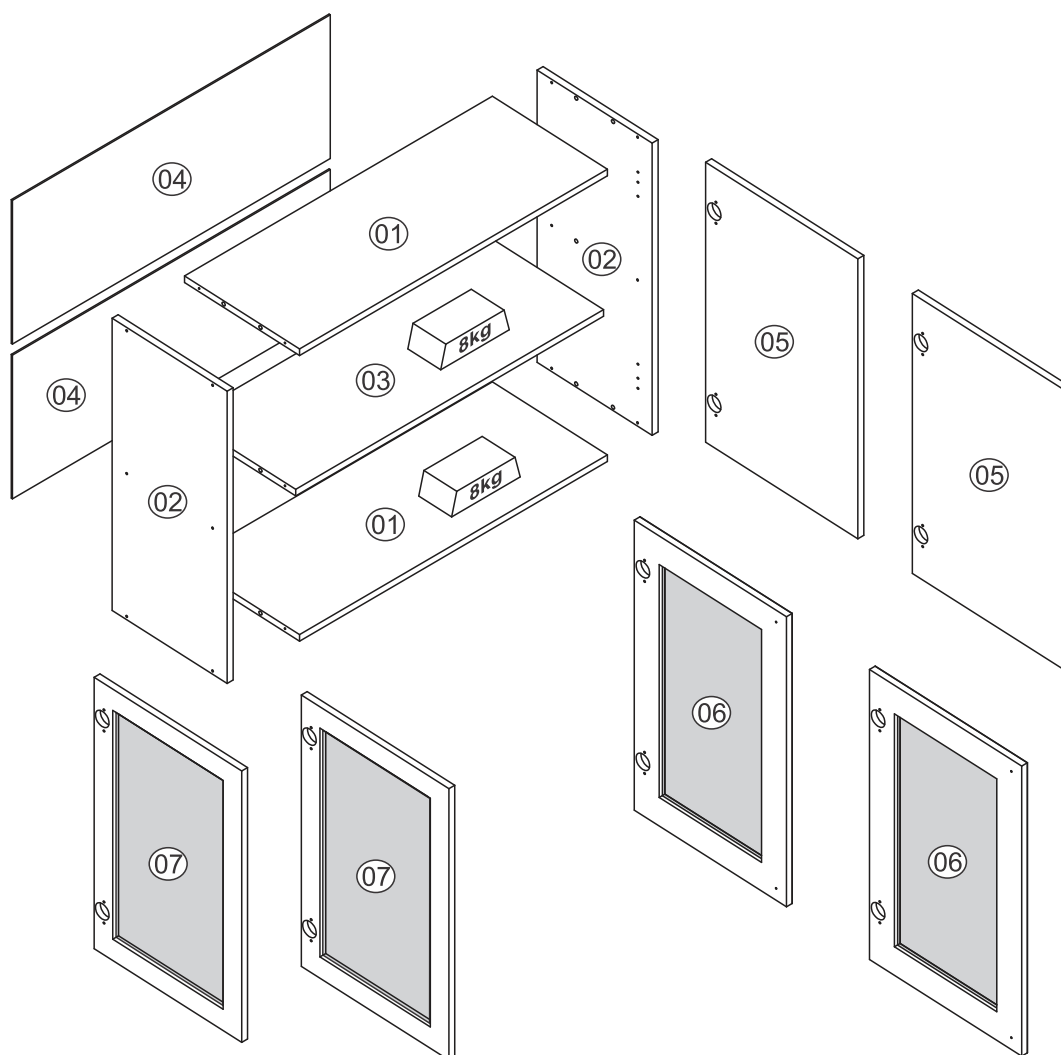









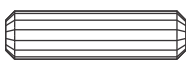

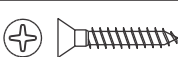
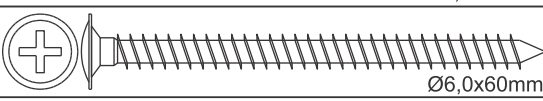
Opcional puxador perfil
Opcional tirador perfil
Optional profile handle

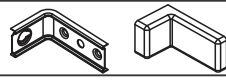
LISTA DE PEÇAS/RELACIÓN PIEZAS/PART LIST

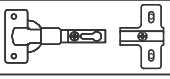
Nº	Código Code	Descrição/Descripción/Description	Dimensão (mm) Dimensiones (mm) Measures (mm)	Qtde. Cantidad Quantity
01	802501	Base/Base/Base	770 x 300 x 15	02
02	802502	Lateral/Side/Lateral	665 x 300 x 15	02
03	802503	Prateleira/Repisa/Shelf	770 x 290 x 15	01
04	800504	Costa/Revés/Back	795 x 327 x 03	02
05	800008	Porta/Puerta/Door (Ref. 8025)	637 x 397 x 15	02
06	Q01319	Porta/Puerta/Door (Ref. 8225)	660 x 397 x 15	02
07	Q01317	Porta/Puerta/Door (Ref. 8025)	637 x 397 x 15	02

FERRAGENS/HERRAJES/HARDWARE

A		Ø4,0x40mm	12
B		Cavilha/Tarugo/Dowel Ø8x30mm	12
C		Ø3,5x14mm	40
D		Ø3,0x25mm	02
E		Ø6,0x60mm	04
F		Prego/Clavo/Nail 10x10	28
G		Bucha/Cojinete/Bush 8mm	04
H			04
I		Garra metálica/Pieza fijación revés/ Back claw 13x13	05
J		Sache cola/Pegamento/Glue	01
K		Dobradiça/Bisagra/Hinge 35mm	04
L		Tapa furo/Tapa agujero/Hole sticker 12mm	12
M		Puxador perfil/Tirador/Handle 397mm Ref. 8025	02
N		Puxador/Tirador/Handle Ref. 8225	02

FERRAMENTAS NECESSÁRIAS

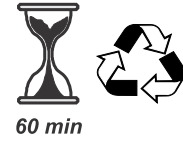
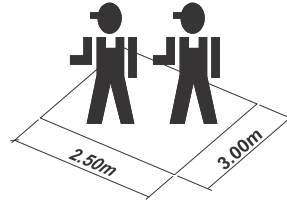
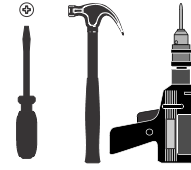

1

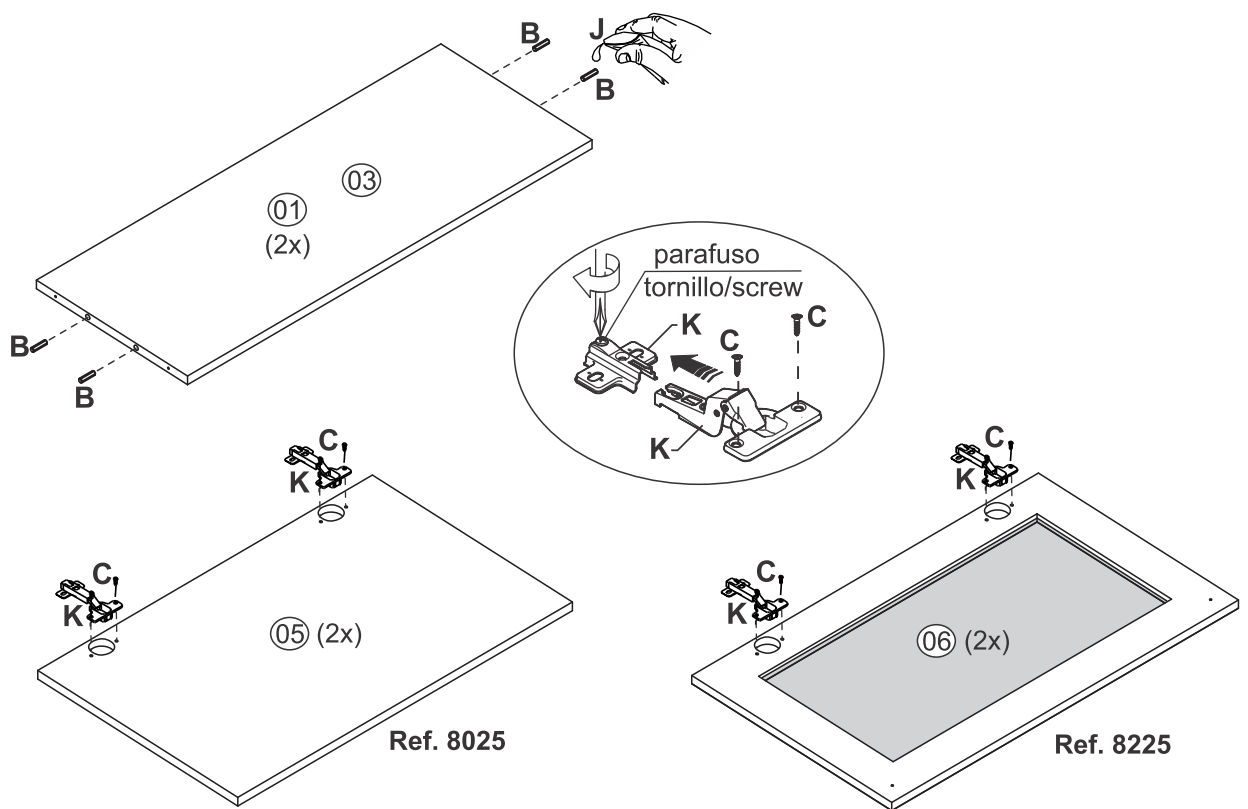

2

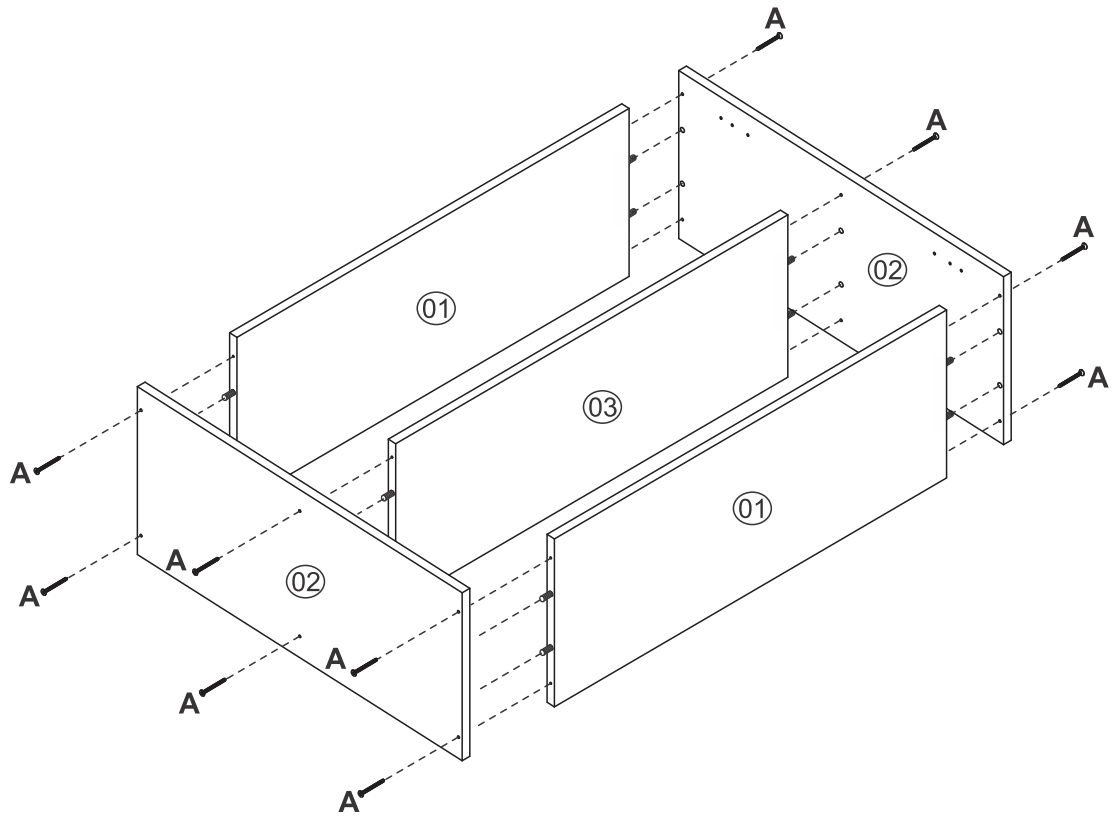

3

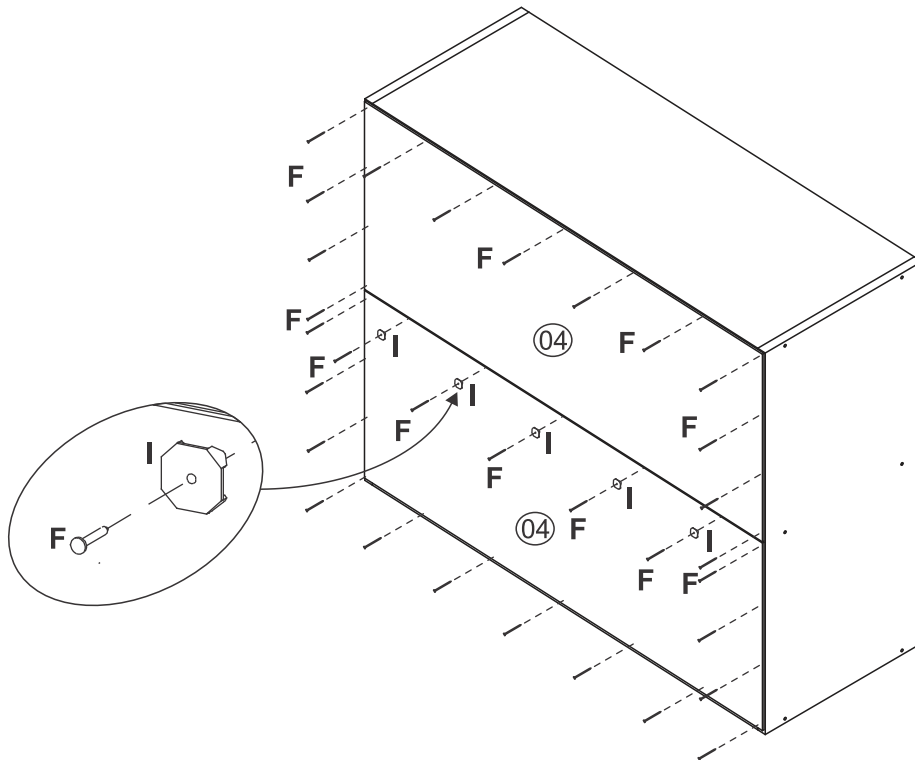

4

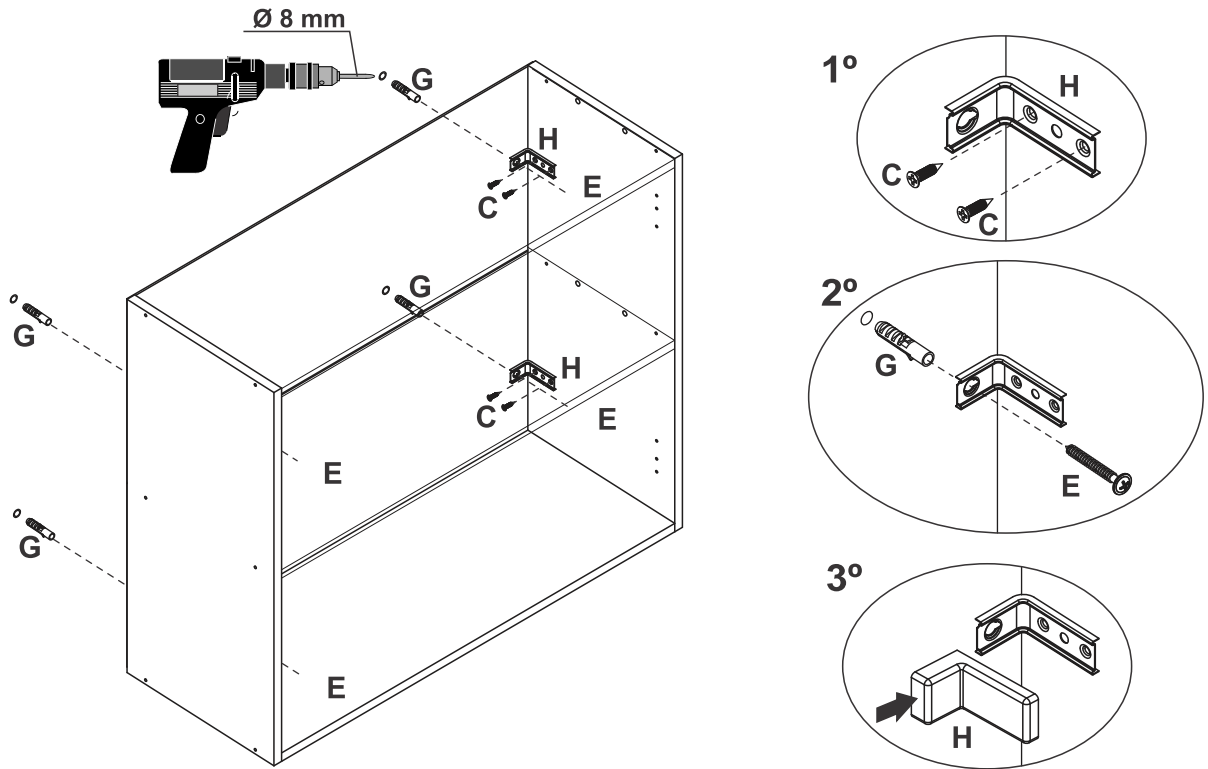

5

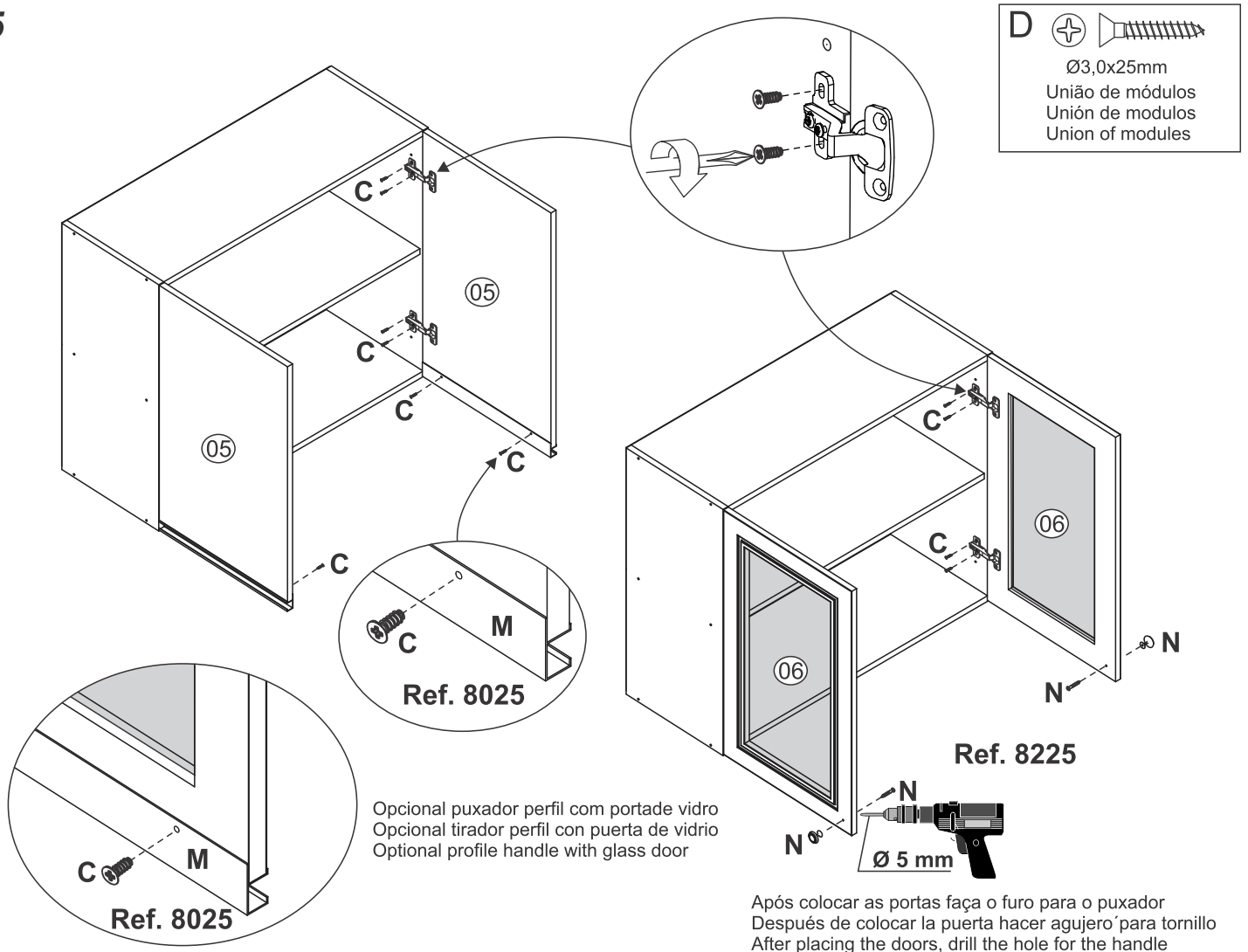

Quiditá

Essência da qualidade

Móveis Quiditá
Bento Gonçalves - RS
Rodovia BR-470 KM 202 - Cep 95710-000
Fone: 0xx (54) 3458-1001
www.quiditamoveis.com.br

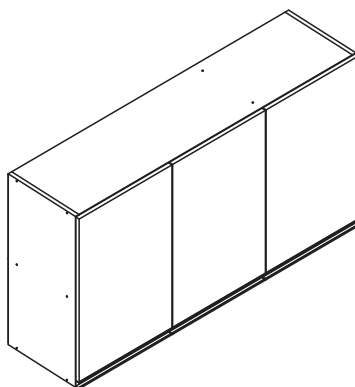



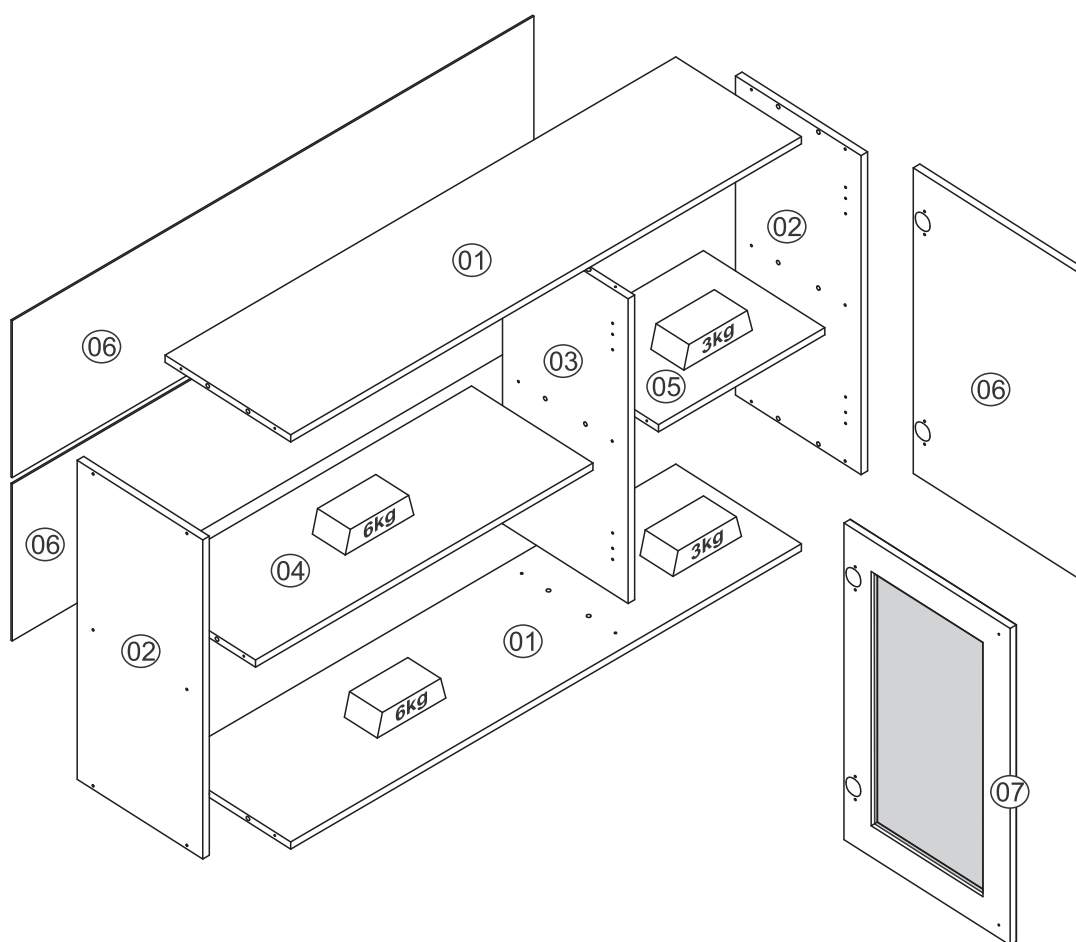





8030

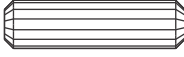
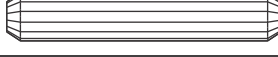

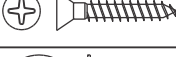

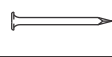

LISTA DE PEÇAS/RELACIÓN PIEZAS/PART LIST

Nº	Código Code	Descrição/Descripción/Description	Dimensão (mm) Dimensiones (mm) Measures (mm)	Qtde. Cantidad Quantity
01	803001	Base/Base/Base	1170 x 300 x 15	02
02	802502	Lateral/Side/Lateral	665 x 300 x 15	02
03	803002	Divisão/Division/División	635 x 300 x 15	01
04	803003	Prateleira maior/Repisa mayor/Large shelf	773 x 290 x 15	01
05	803004	Prateleira menor/Repisa menor/Small shelf	381 x 290 x 15	01
05	801010	Costa/Revés/Back	1195 x 327 x 03	02
06	800008	Porta/Puerta/Door (Ref. 8030)	637 x 397 x 15	03
07	Q01306	Porta/Puerta/Door (Ref. 8230)	660 x 397 x 15	03

FERRAGENS/HERRAJES/HARDWARE

A		Ø4,0x40mm	18
B		Cavilha/Tarugo/Dowel Ø8x30mm	16
C		Cavilha/Tarugo/Dowel Ø8x50mm	02
D		Ø3,5x14mm	54
E		Ø3,0x25mm	02
F		Ø6,0x60mm	04
G		Prego/Clavo/Nail 10x10	33
H		Bucha/Cojinete/Bush 8mm	04
I			04
J		Garra metálica/Pieza fijación revés/ Back claw 13x13	07

K		Sache cola/Pegamento/Glue	01
L		Dobradiça/Bisagra/Hinge 35mm	06
M		Tapa furo/Tapa agujero/Hole sticker 12mm	16
N		Puxador perfil/Tirador/Handle 397mm Ref. 8030	03
O		Puxador/Tirador/Handle Ref. 8230	03

FERRAMENTAS NECESSÁRIAS

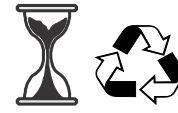
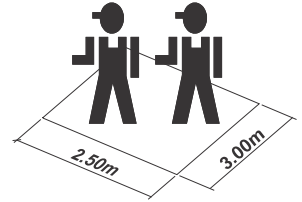
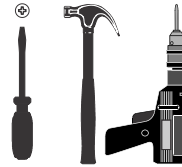

60 min

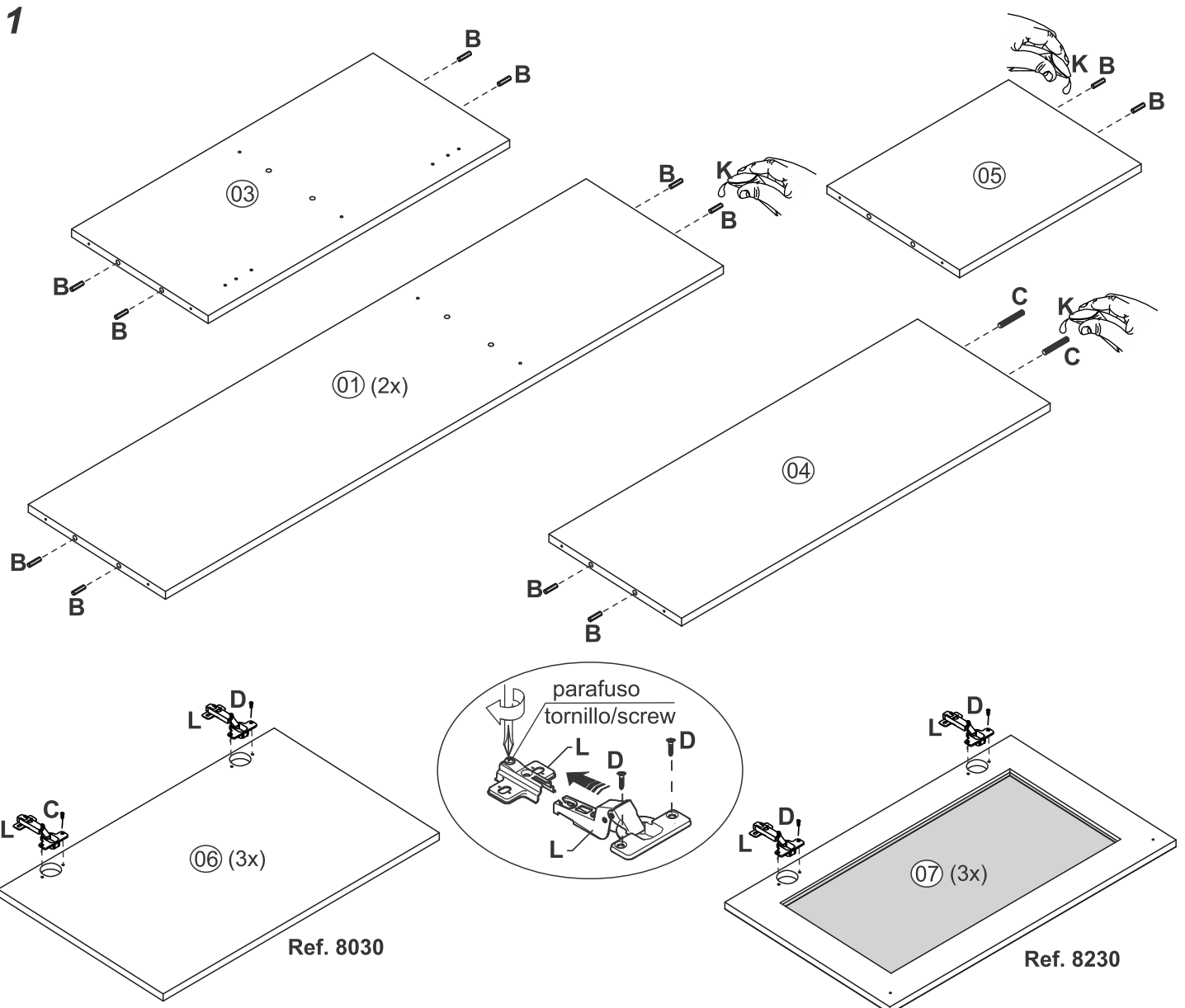

2

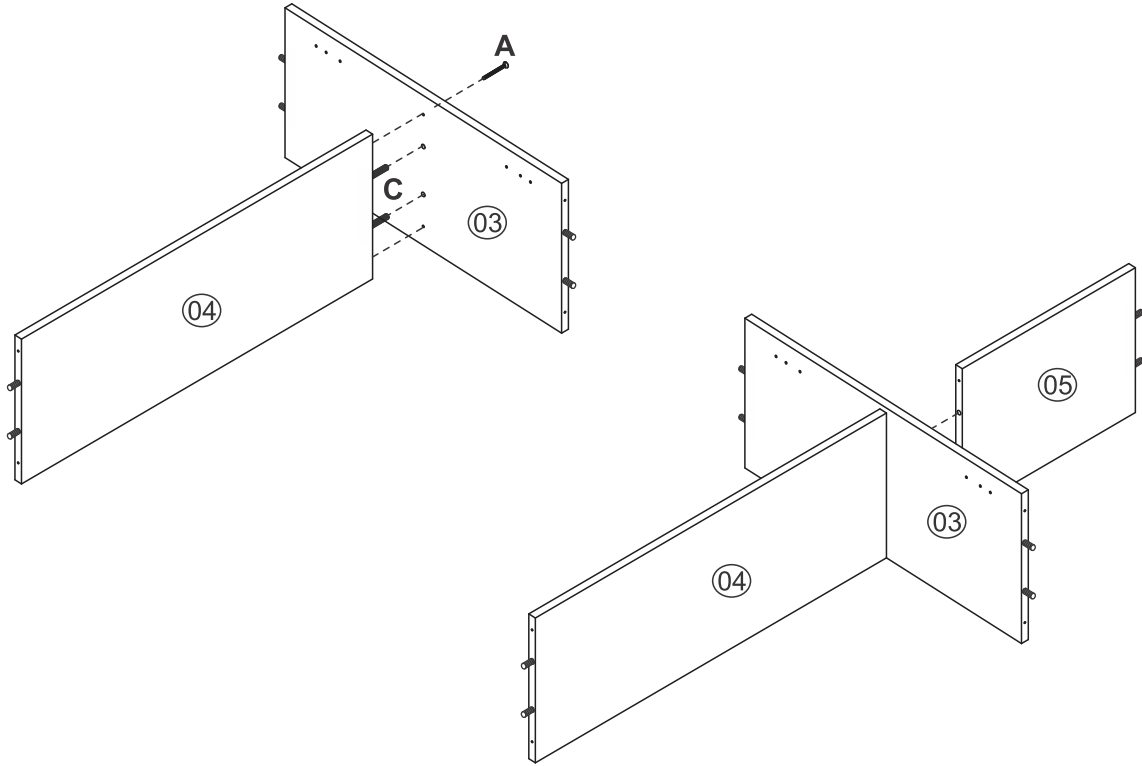

3

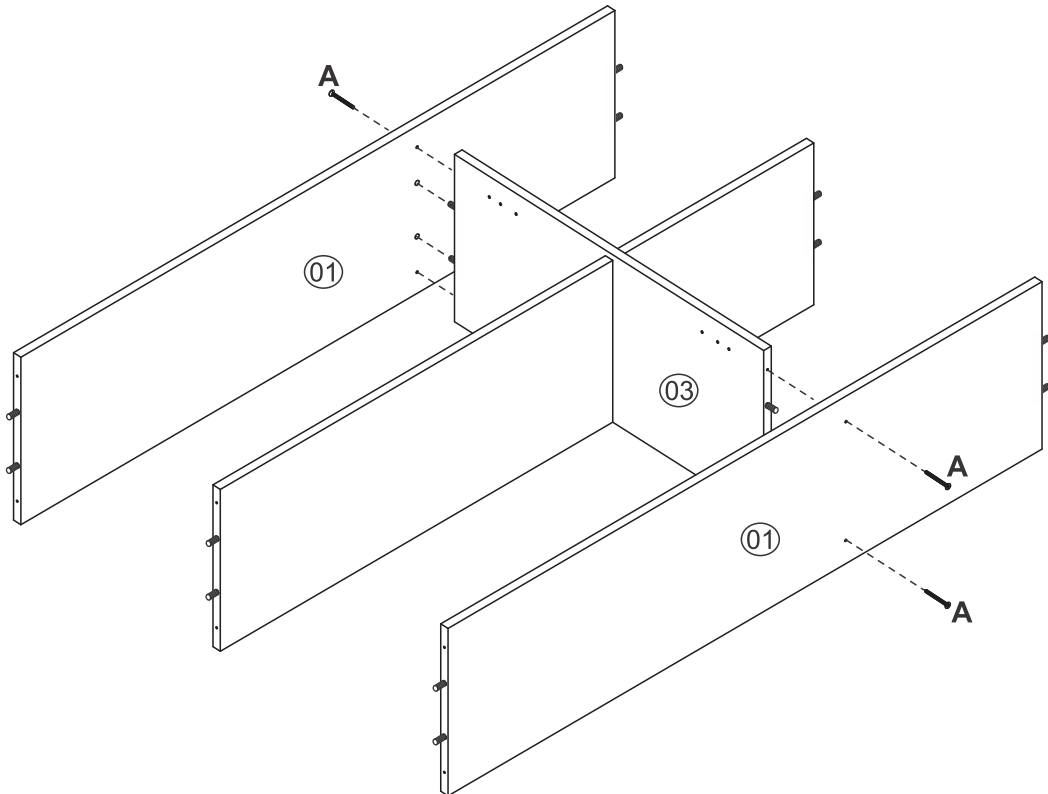

4

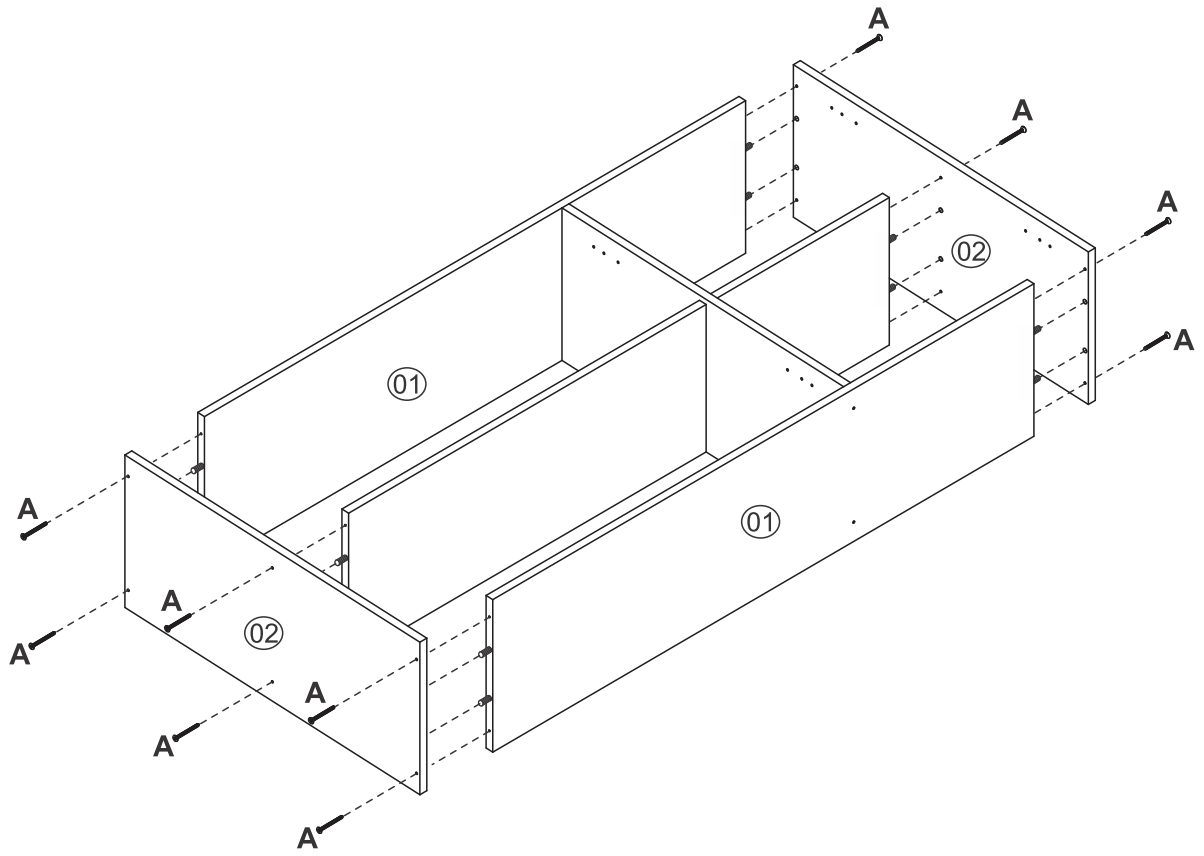

5

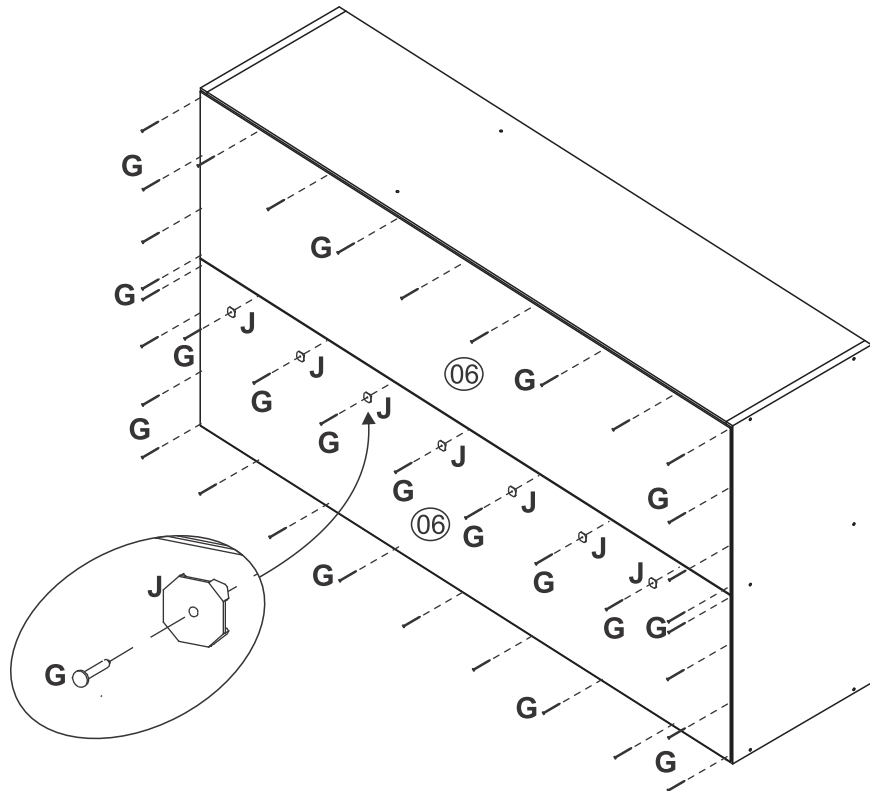

6

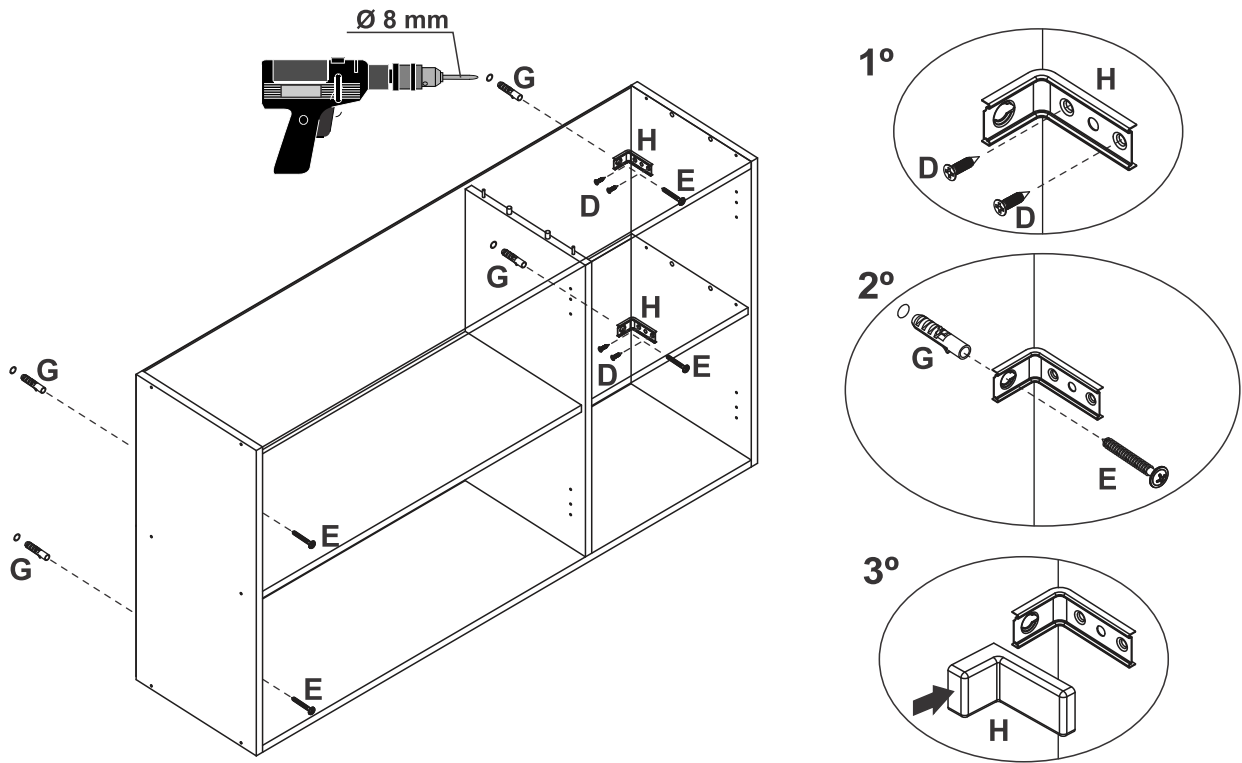

7

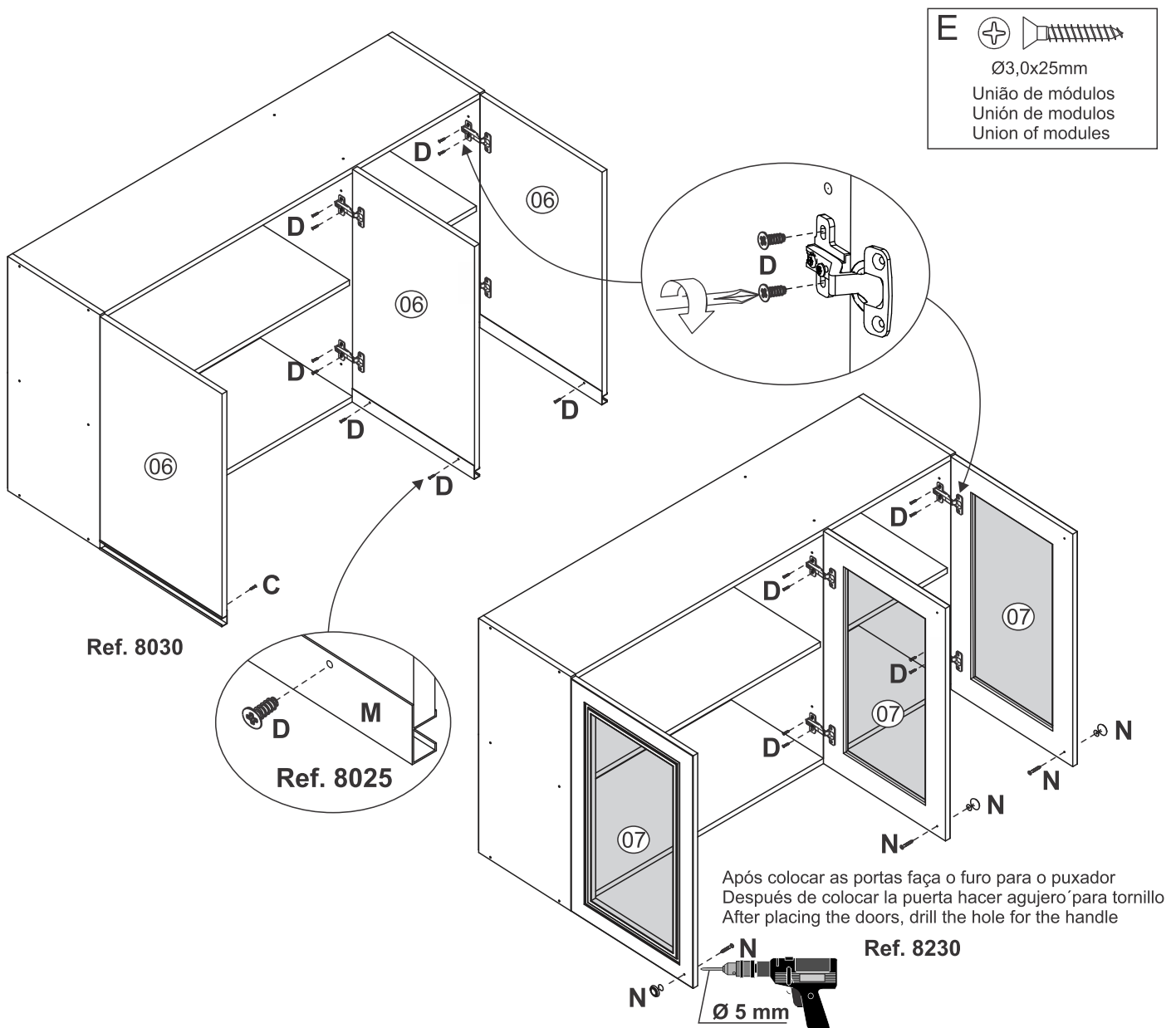

Quiditá

Essência da qualidade

Móveis Quiditá
Bento Gonçalves - RS
Rodovia BR-470 KM 202 - Cep 95710-000
Fone: 0xx (54) 3458-1001
www.quiditamoveis.com.br

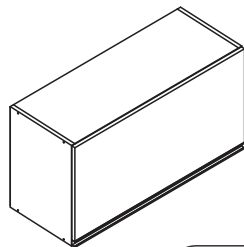

8040

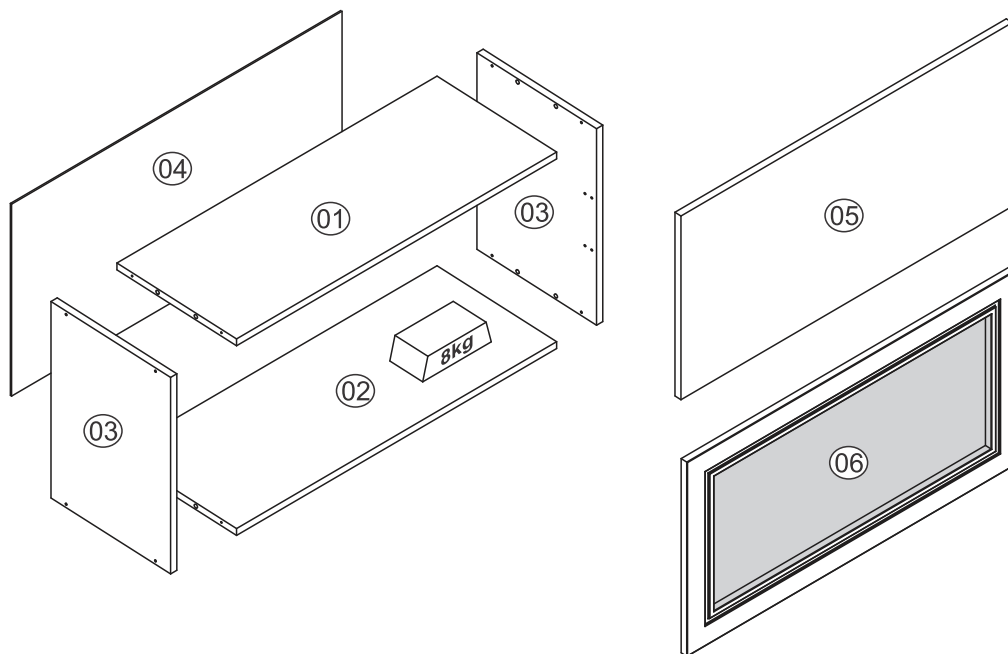

LISTA DE PEÇAS/RELACIÓN PIEZAS/PART LIST

8035

8235

Nº	Código Code	Descrição/Descripción/Description	Dimensão (mm) Dimensiones (mm) Measures (mm)	Qtde. Cantidad Quantity
01	803501	Tampo/Tapa/Top	770 x 300 x 15	01
02	802501	Base/Base/Base	770 x 300 x 15	01
03	803503	Lateral/Side/Lateral	332 x 300 x 15	02
04	800504	Costa/Revés/Back	795 x 327 x 03	01
05	803505	Porta/Puerta/Door (Ref. 8035)	797 x 305 x 15	01
06	Q01310	Porta/Puerta/Door (Ref. 8235)	797 x 328 x 15	01











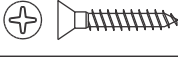
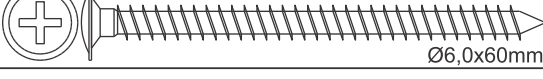

LISTA DE PEÇAS/RELACIÓN PIEZAS/PART LIST

8040

8240

Nº	Código Code	Descrição/Descripción/Description	Dimensão (mm) Dimensiones (mm) Measures (mm)	Qtde. Cantidad Quantity
01	803501	Tampo/Tapa/Top	770 x 300 x 15	01
02	802501	Base/Base/Base	770 x 300 x 15	01
03	804001	Lateral/Side/Lateral	430 x 300 x 15	02
04	804003	Costa/Revés/Back	795 x 420 x 03	01
05	804004	Porta/Puerta/Door (Ref. 8040)	797 x 402 x 15	01
06	Q01311	Porta/Puerta/Door (Ref. 8240)	797 x 425 x 15	01

FERRAGENS/HERRAJES/HARDWARE

A		Ø4,0x40mm	08
B		Cavilha/Tarugo/Dowel Ø8x30mm	08
C		Ø3,5x14mm	27
D		Ø3,0x25mm	02
E		Ø6,0x60mm	04
F		Prego/Clavo/Nail 10x10	20
G		Bucha/Cojinete/Bush 8mm	04
H		Suporte parede Soporte pared Wall support	04
I		Sache cola/Pegamento/Glue	01
J		Pistão a gás/Pistón de gás/Piston	01
K		Dobradiça/Bisagra/Hinge 35mm	02
L		Tapa furo/Tapa agujero/Hole sticker 12mm	16
M		Puxador perfil/Tirador/Handle 797mm Ref. 8035/8040	01
N		Puxador/Tirador/Handle Ref. 8235/8240	01

FERRAMENTAS NECESSÁRIAS

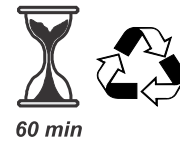
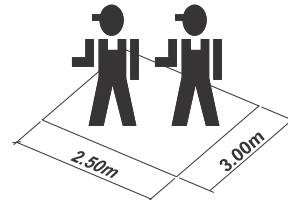
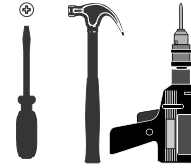

1

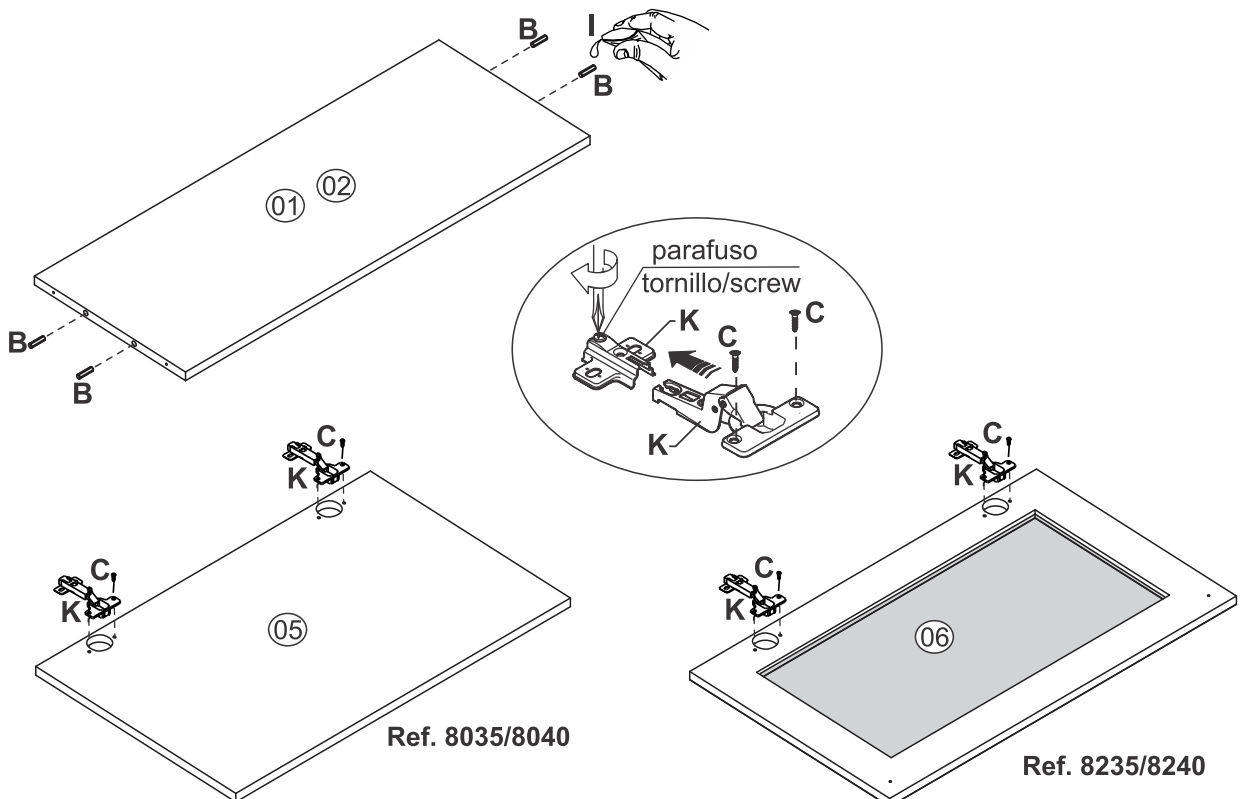

2

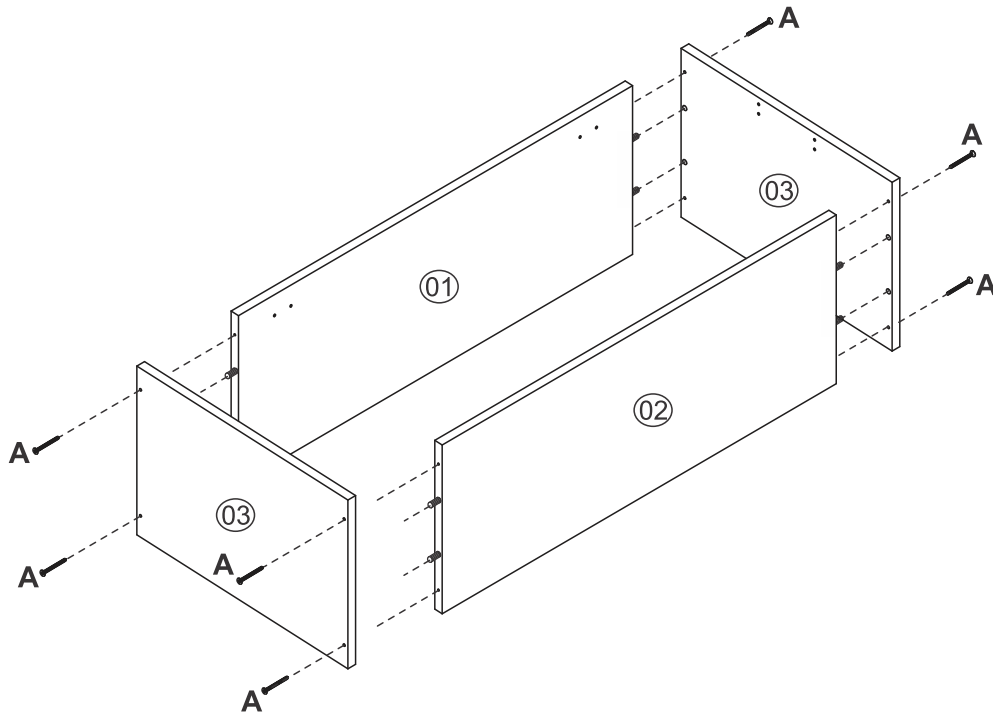

3

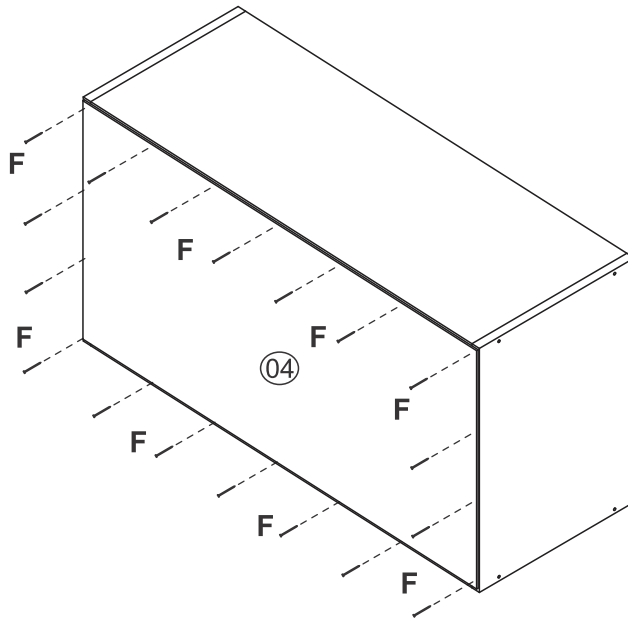

4

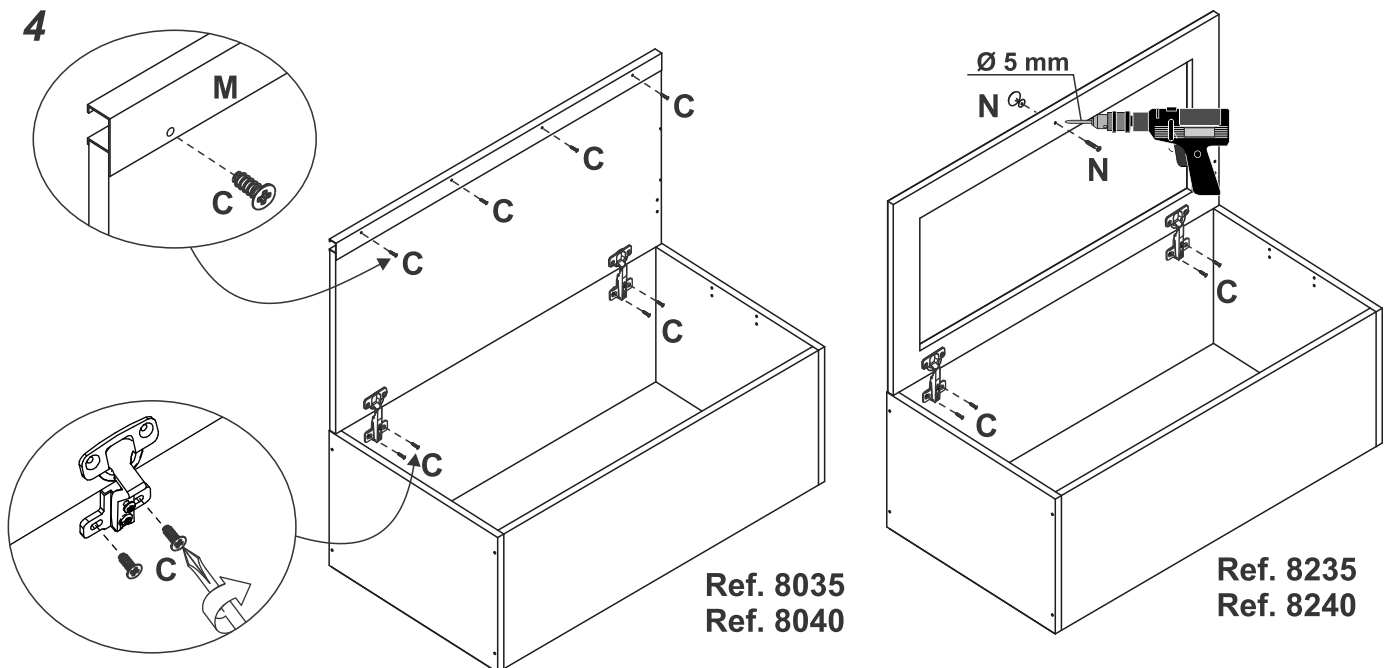

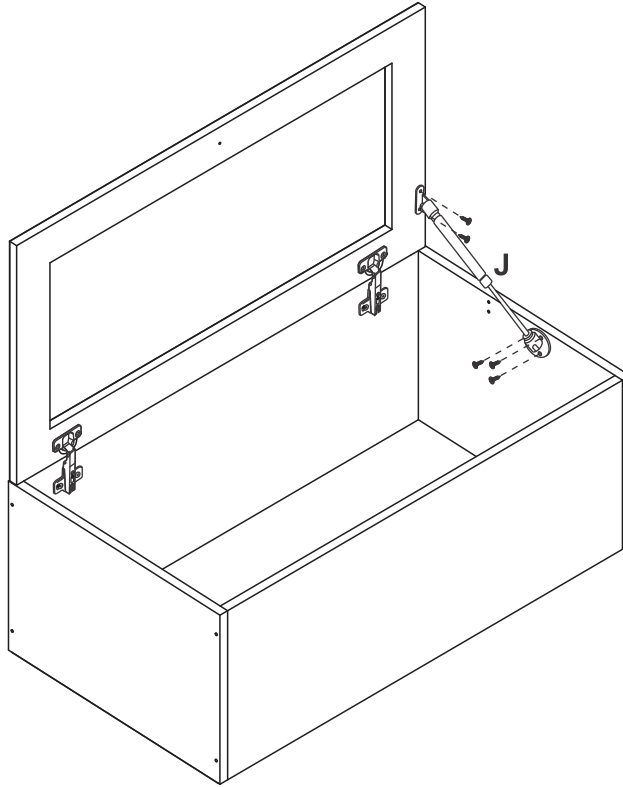

5

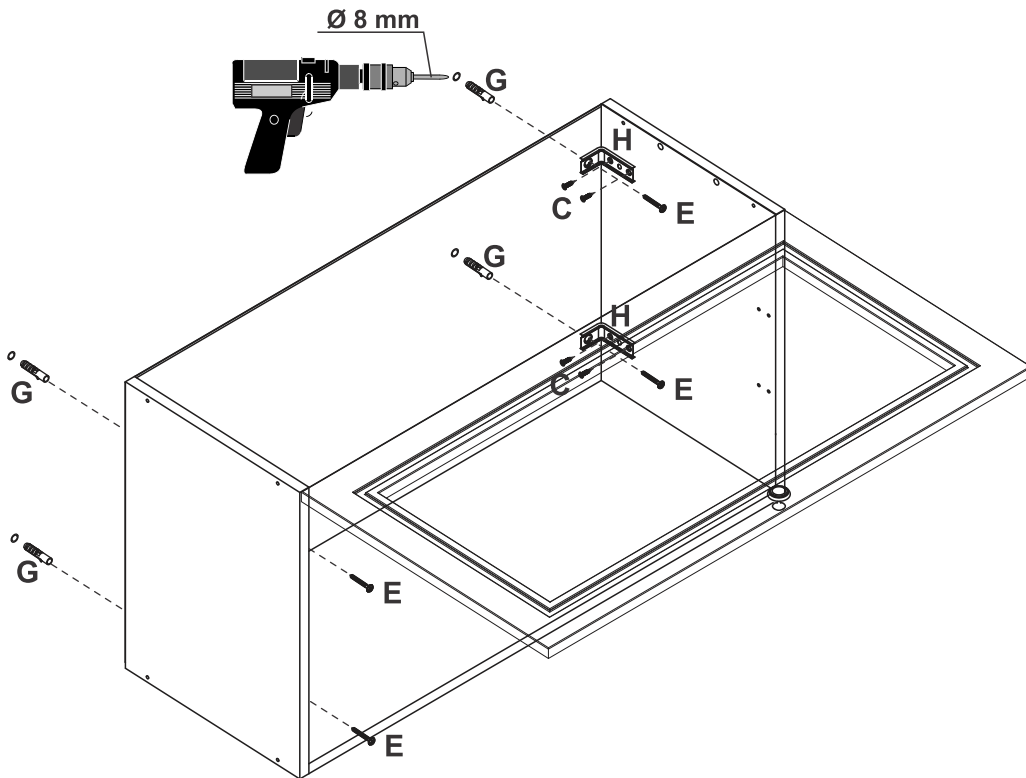

6



D  
Ø3,0x25mm
União de módulos
Unión de módulos
Union of modules

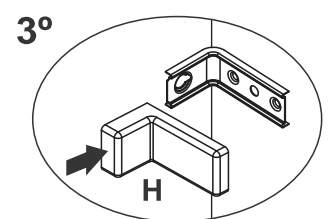
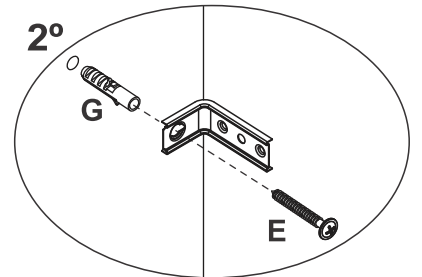
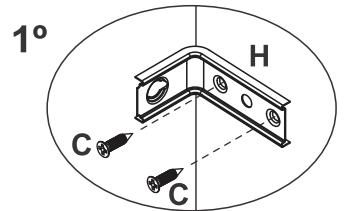

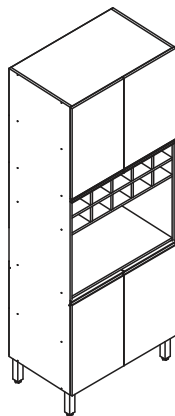

8065

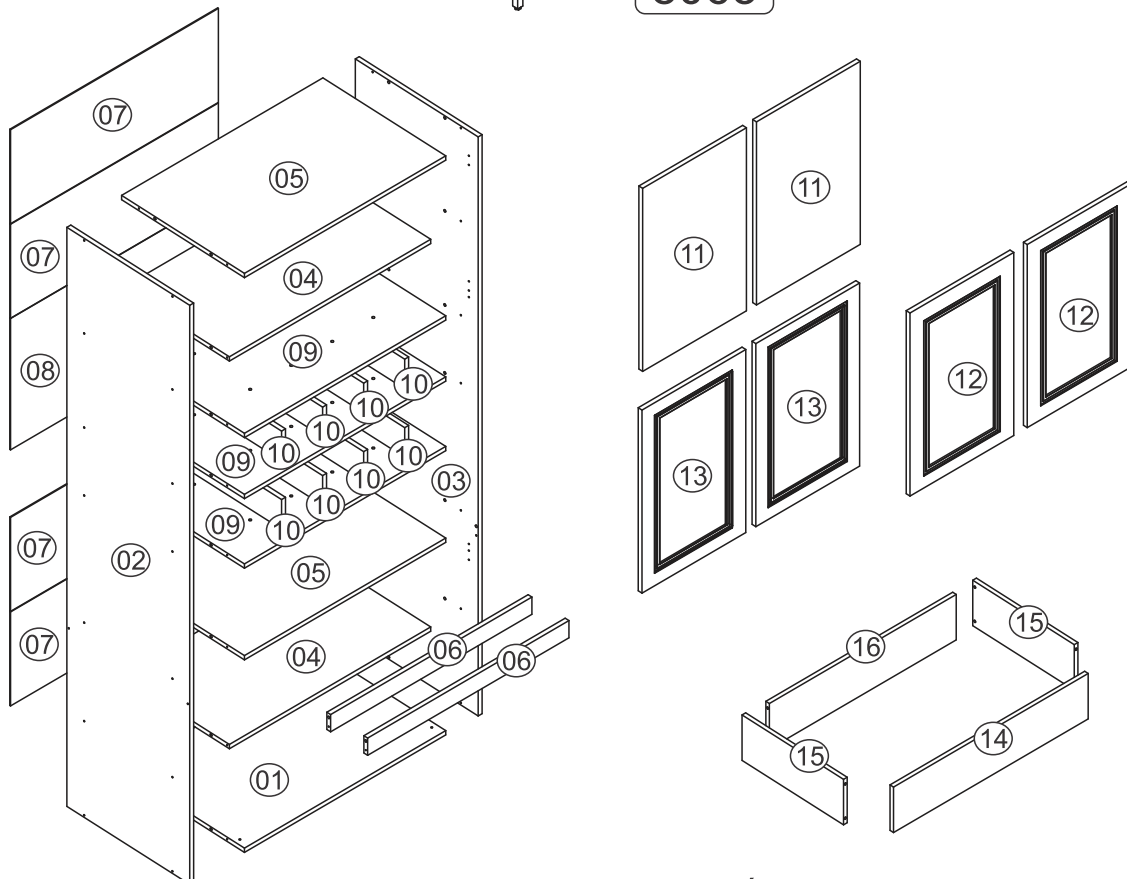

LISTA DE PEÇAS/RELACIÓN PIEZAS/PART LIST

Ref. 8065/8265

FERRAMENTAS NECESSÁRIAS
HERRAMIENTAS NECESARIAS
NECESSARY TOOLS/

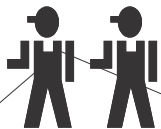
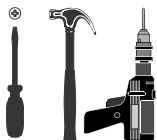









60 min

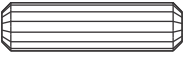
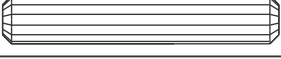



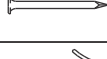

Nº	Código Code	Descrição/Descripción/Description	Dimensão (mm) Dimensiones (mm) Measures (mm)	Qtde. Cantidad Quantity
01	800501	Base/Base/Base	770 x 490 x 15	01
02	806502	Lateral esquerda/Left side/L teral izquierda	2015 x 490 x 15	01
03	806501	Lateral direita/Right side/Lateral derecha	2015 x 490 x 15	02
04	800502	Prateleira/Repisa/Shelf	770 x 430 x 15	02
05	806002	Prateleira/Repisa/Shelf	770 x 490 x 15	02
06	800503	Travessa/Traverse/Travessaño	770 x 60 x 15	02
07	800504	Costa/Revés/Back	795 x 327 x 3	04
08	806005	Costa/Revés/Back	795 x 457 x 3	01
09	806503	Prateleira adega/Repisa del sótano/Wine cellar shelf	770 x 490 x 15	03
10	806504	Travessa adega/Travessaño del sótano/Wine cellar traverse	103 x 380 x 15	08
11	800008	Porta/Puerta/Door (Ref. 8065)	637 x 397 x 15	04
12	Q01306	Porta/Puerta/Door (Ref. 8265)	660 x 397 x 15	02
13	Q01309	Porta/Puerta/Door (Ref. 8265)	660 x 397 x 15	02

Ref. 8265



14	811001	Rodapé frontal/Front baseboard/Zócalo delantero	800 x 170 x 15	01
15	810501	Rodapé lateral/Side baseboard/Zócalo lateral	435 x 170 x 15	02
16	811002	Rodapé traseiro/Back baseboard/Zócalo de atras	768 x 170 x 15	01

FERRAGENS/HERRAJES/HARDWARE

A		Ø4,0x40mm	32
B		Cavilha/Tarugo/Dowel Ø8x30mm	48
C		Cavilha/Tarugo/Dowel Ø8x50mm	08
D		Ø3,5x14mm	68
E		Ø3,5x25mm	04
F		Ø6,0x60mm	04
G		Ø5,0x50mm	04
H		Prego/Clavo/Nail 10x10	67
I		Bucha/Cojinete/Bush 8mm	04
J			04
K		Garra metálica/Pieza fijación revés/ Back claw 13x13	15

L		Sache cola/Pegamento/Glue	01
M		Tapa furo/Tapa agujero/Hole sticker 12mm	48
N		Puxador perfil/Tirador/Handle 397mm Ref. 8065	04
O		Puxador/Tirador/Handle Ref. 8265	04
P		Dobradiça/Bisagra Hinge 35mm	08
Q			04

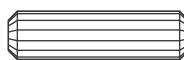
ROD400

B		Cavilha/Tarugo/Dowel Ø8x30mm	08
D		Ø3,5x14mm	32
P			16

1

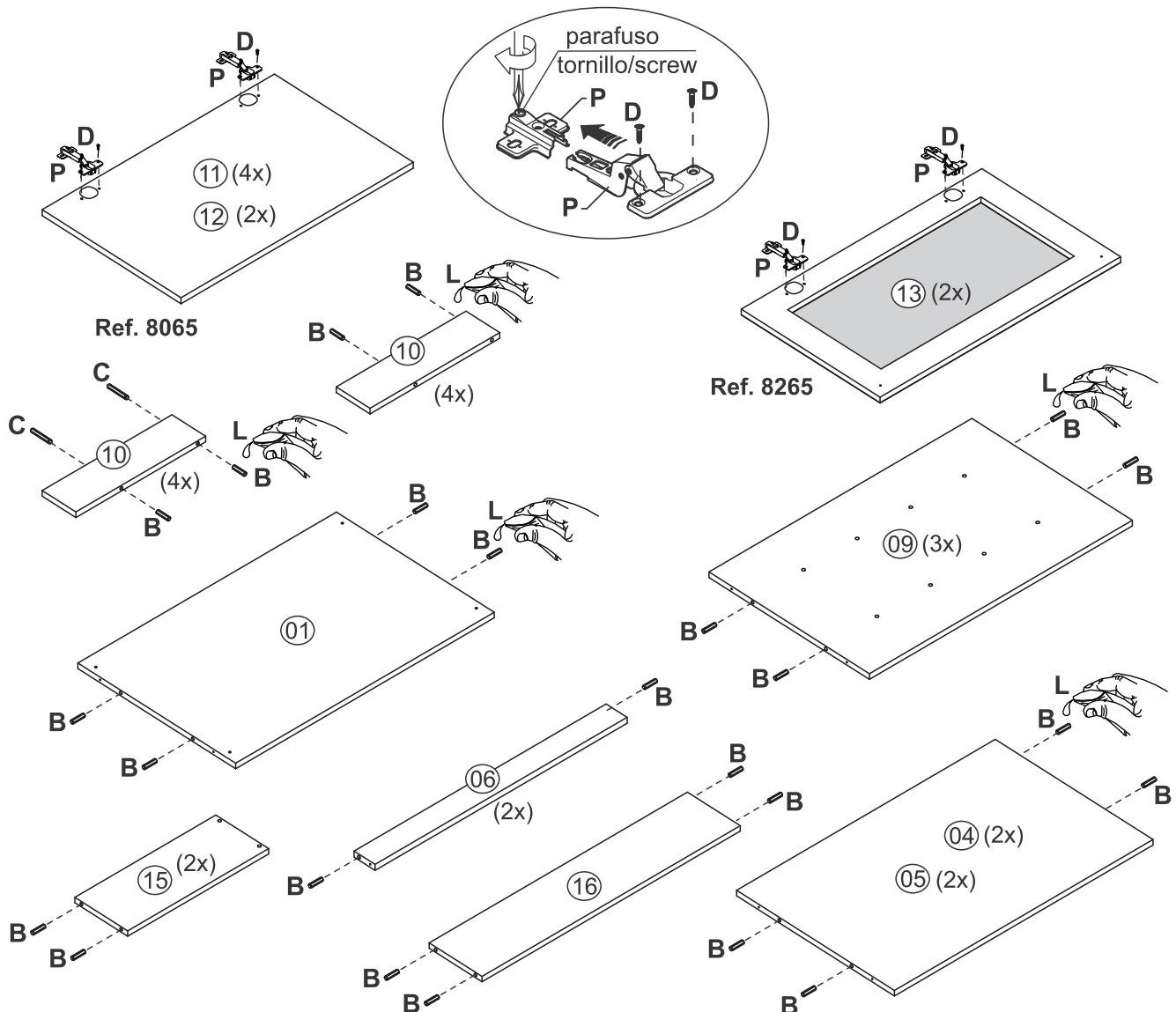

2 Ref. 8065/8265

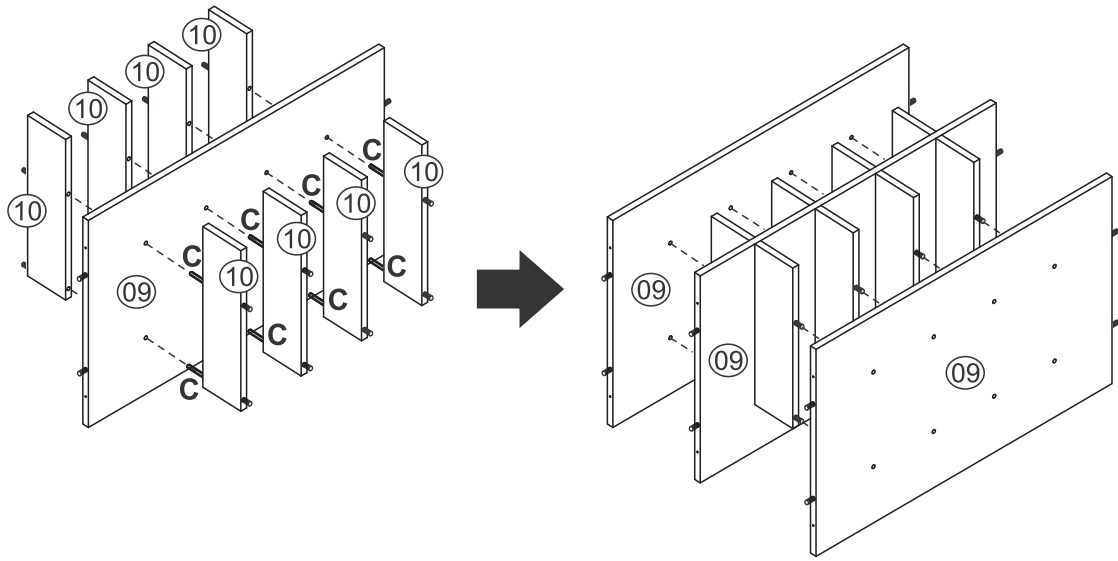

3 Ref. 8065/8265

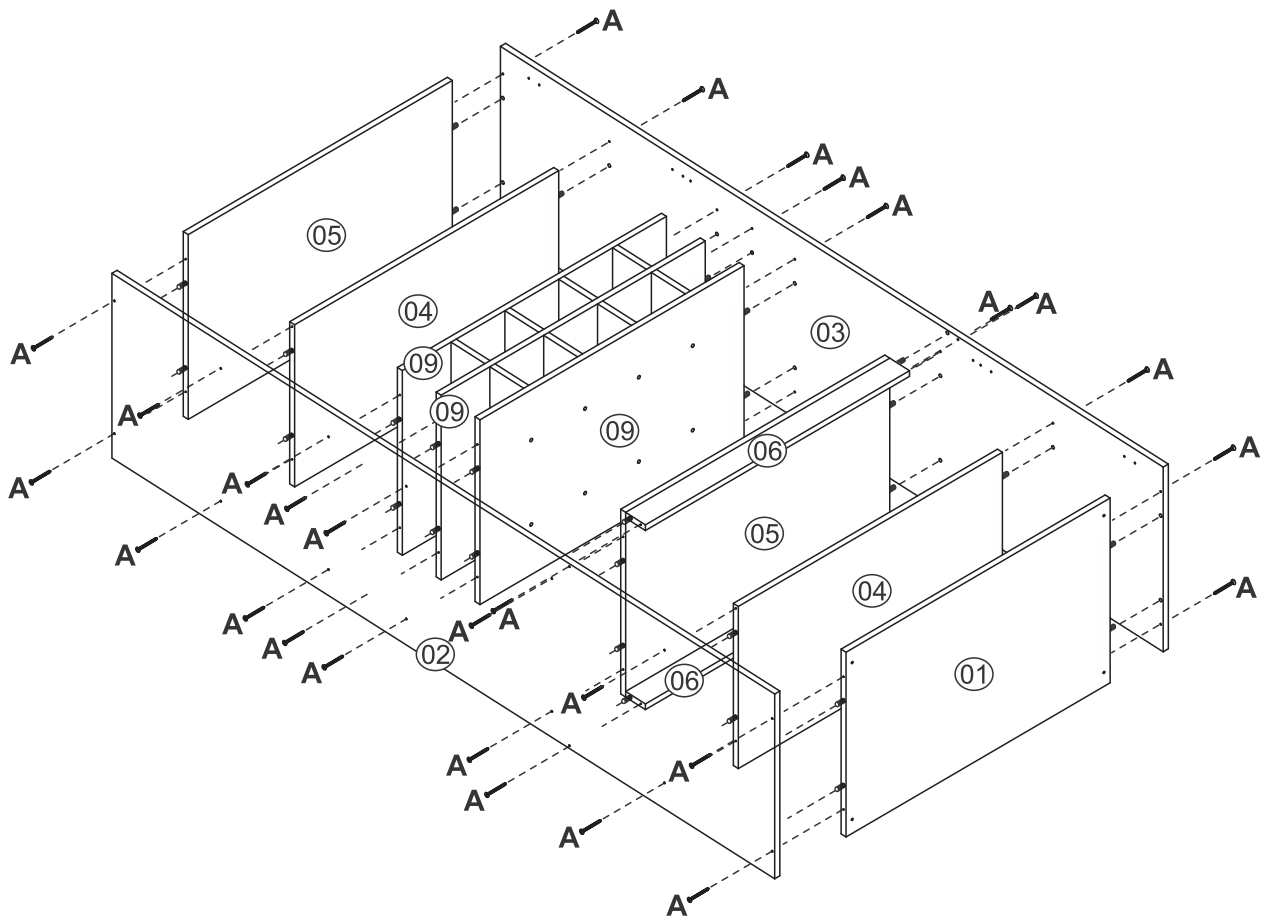

4 - Ref. 8065

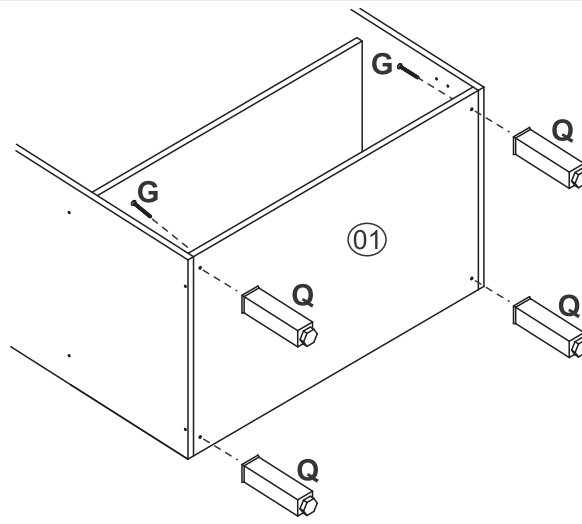

4 - Ref. 8265

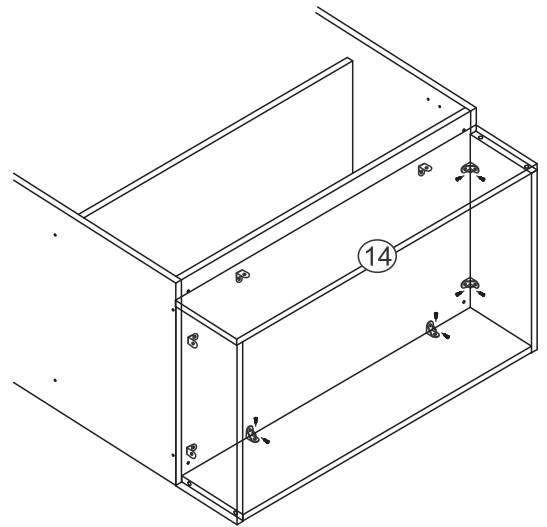
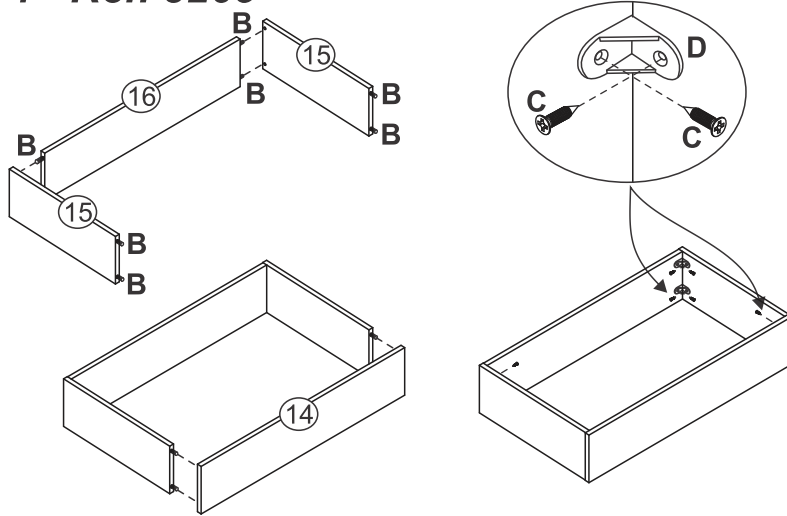

5

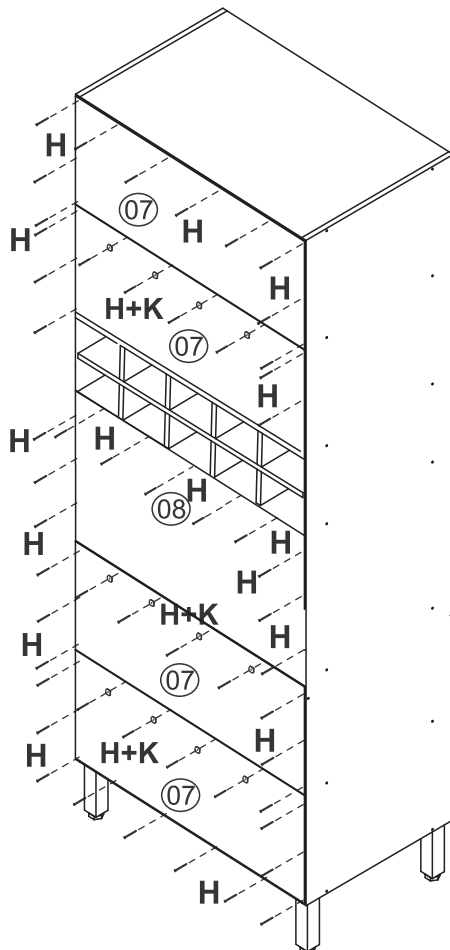

SE UTILIZAR FORNO ELÉTRICO, NÃO FIXAR A COSTA Nº 08
 SI USA UN HORNO ELÉCTRICO, NO FIJAR EL RESPALDO Nº 08
 IF USING AN ELETRIC OVEN, DO NOT FIX THE BACK NUMBER 08

6 Fixação na parede / Fixing in the wall / Fijación en pared - opcional

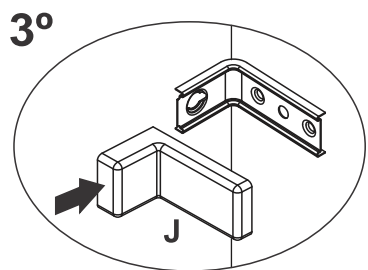
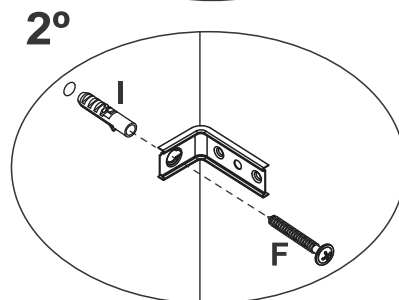
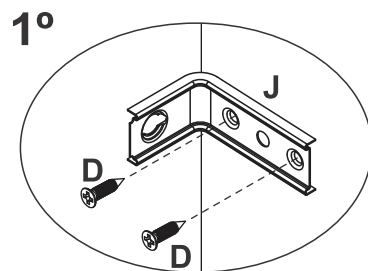
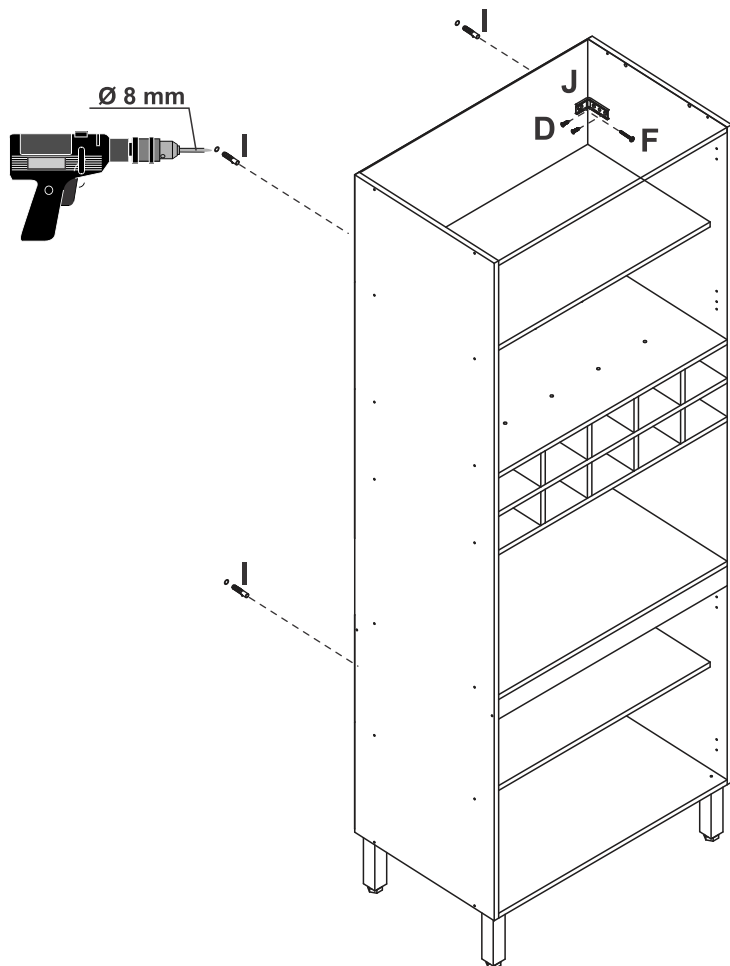

7

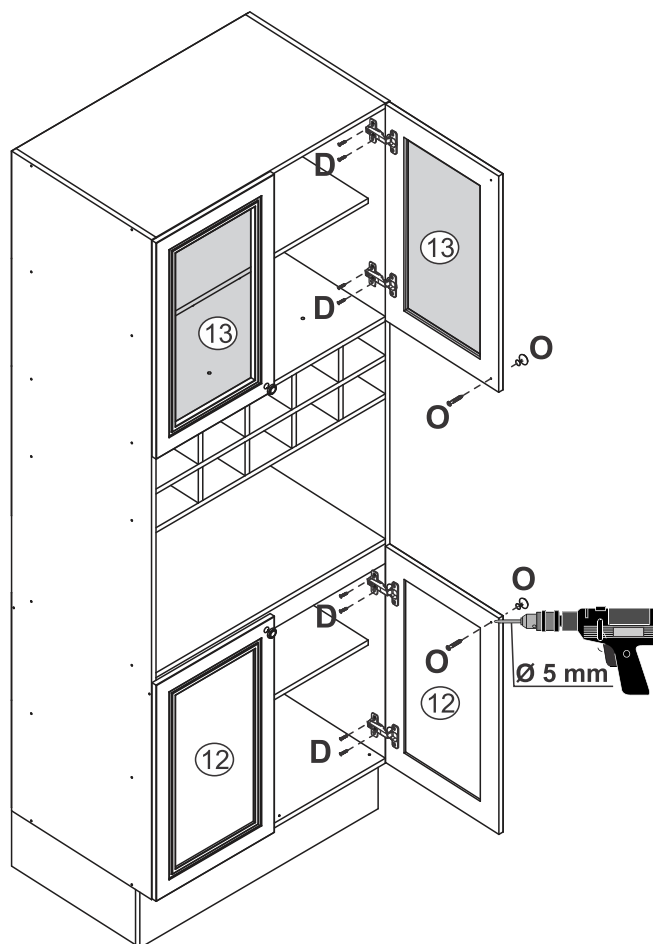
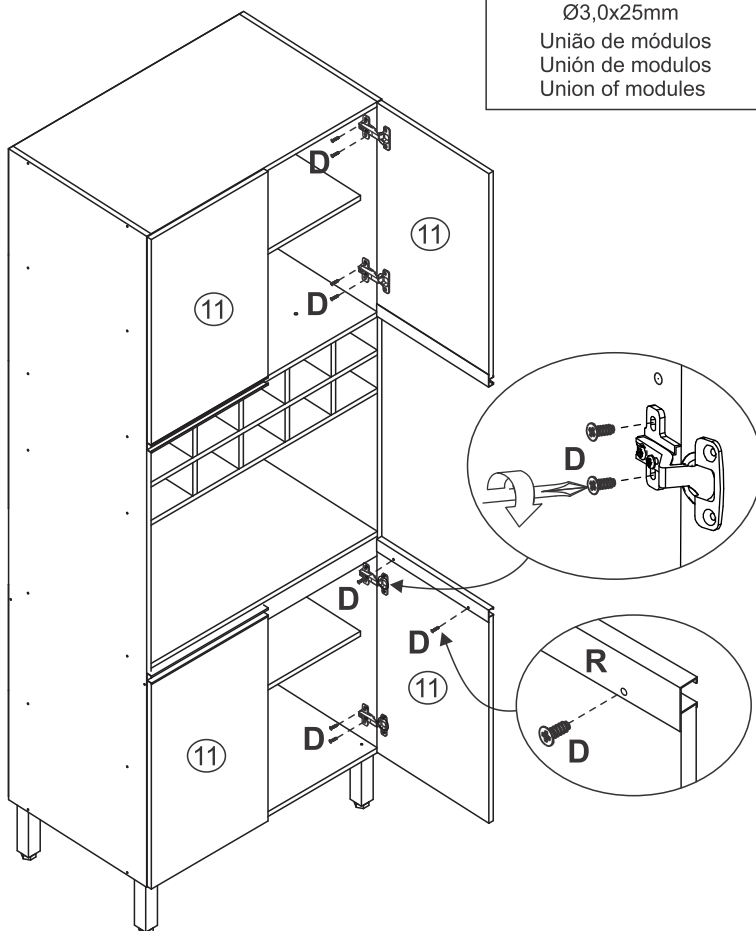
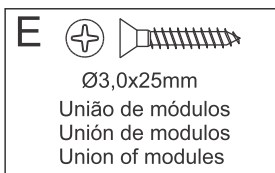

Após colocar as portas faça o furo para o puxador
 Después de colocar la puerta hacer agujero para tornillo
 After placing the doors, drill the hole for the handle