

ASSEMBLY INSTRUCTIONS MANUAL DE MONTAGEM / INSTRUCCIONES DE ARMADO

CAMPANELE CABINET 2 DOORS 30 1/8"
BALCÃO 2 PORTAS 766MM CAMPANELE
GABINETE 2 PUERTAS 766MM CAMPANELE

Reference | Revise
Referência | Revisão **01**
Referencia | Revisión

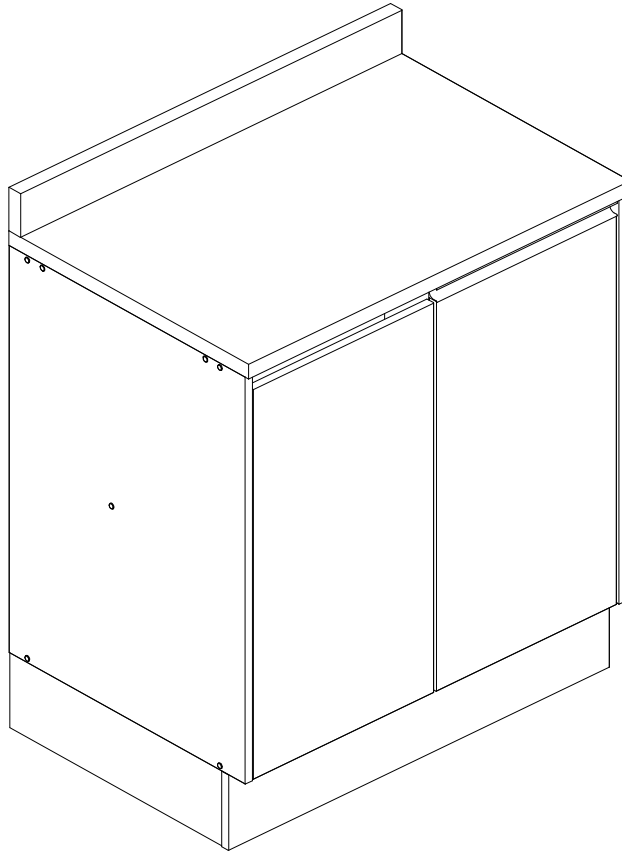

YOU WILL NEED / VOCÊ VAI PRECISAR DE / USTED NECESITARÁ

Tools not supplied / Ferramentas não fornecidas / Herramientas no incluidas

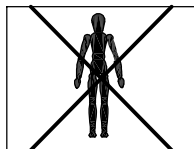

1 Person
1 Pessoa
1 Persona

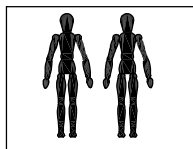

2 People
2 Pessoas
2 Personas

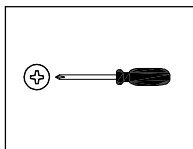

Screwdriver Phillips
Chave Phillips
Destornillador cruz

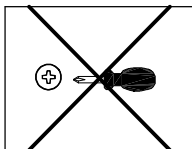

Small screwdriver Phillips
Chave Phillips Menor
Destornillador cruz menor

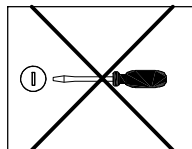

Screwdriver slotted
Chave fenda
Destornillador plano

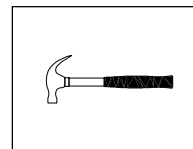

Hammer
Martelo
Martillo

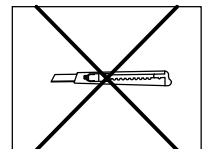

Stylet
Estilete
Estilete

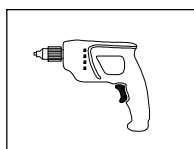

Drill machine
Furadeira
Taladro

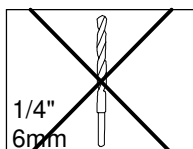

Drill bit
Broca
Taladro

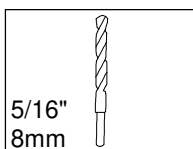

Drill bit
Broca
Taladro

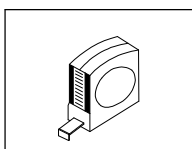

Measuring tape
Trena
Cinta de medición

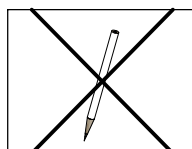

Pencil
Lápis
Lápiz

NOTES: The separation of the accessories before you start the assembly will facilitate the same. In case of doubt on the size of
NOTAS: the screws and bolts, use the ruler to bottom of page 3.

NOTAS: A separação dos acessórios antes de iniciar a montagem facilitará a mesma. Em caso de dúvida no tamanho dos parafusos e cavilhas, utilize a régua ao final da página 3.
La separación de los accesorios antes de comenzar el armado facilitará el mismo. En caso de duda sobre el tamaño de los tornillos y taquetes, utilice la regla al pie de página 3.

MAXIMUM RECOMMENDED WEIGHT
BEING THIS EVENLY DISTRIBUTED
PESO MÁXIMO RECOMENDADO SENDO
ESTE DISTRIBUÍDO UNIFORMEMENTE
PESO MÁXIMO RECOMENDADO SIENDO
ESTE UNIFORMEMENTE DISTRIBUIDO

	LB	KG
A	44	20
B	22	10

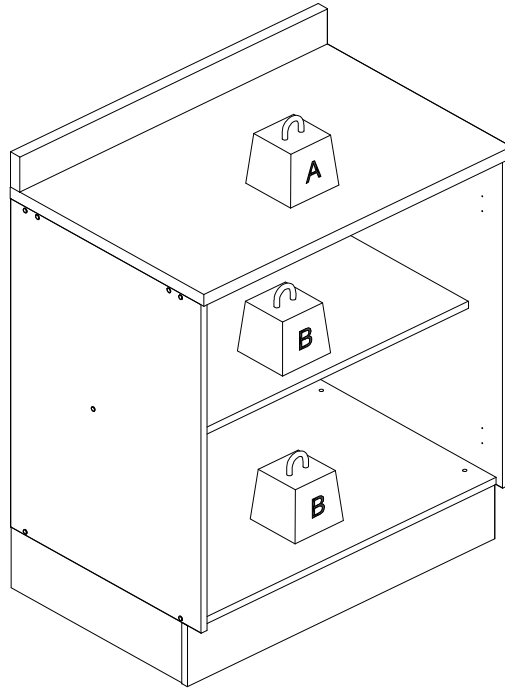





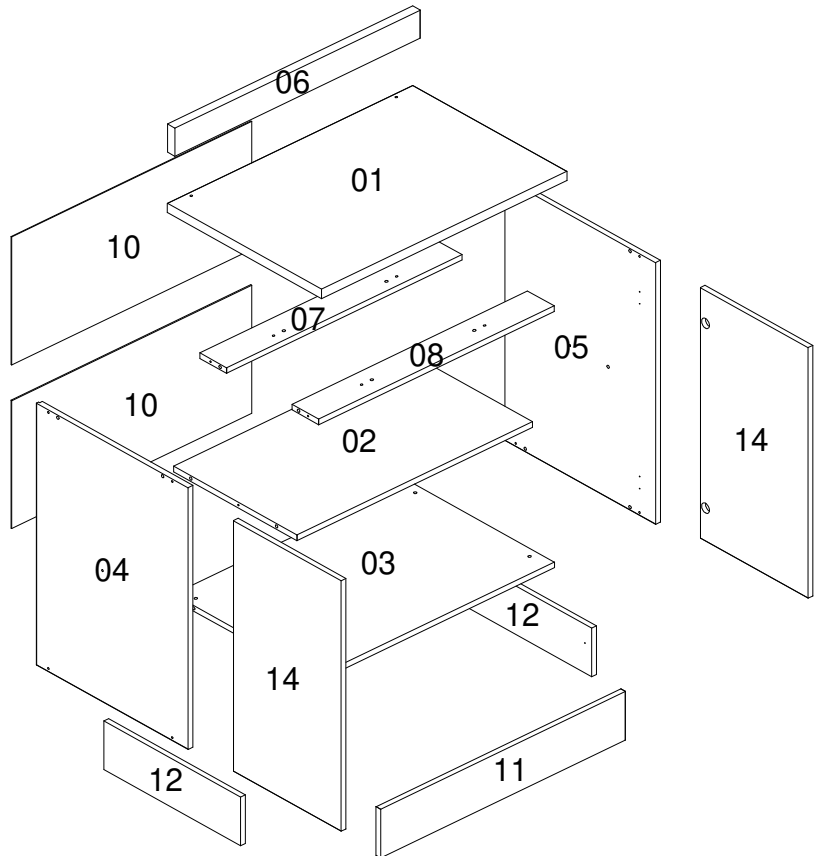



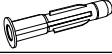

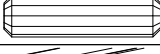
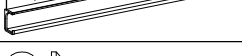



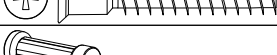

Nº	Measures Inches	Medidas cm	Qty./Qtd.
01	30 1/8 x 20 3/8 x 1	76,6 x 51,8 x 2,5	1
02	28 7/8 x 16 3/8 x 5/8	73,5 x 41,5 x 1,5	1
03	19 3/8 x 28 7/8 x 5/8	49,3 x 73,5 x 1,5	1
04	20 1/8 x 27 1/2 x 5/8	51 x 70 x 1,5	1
05	20 1/8 x 27 1/2 x 5/8	51 x 70 x 1,5	1
06	30 1/8 x 3 x 1	76,6 x 7,5 x 2,5	1
07	28 7/8 x 3 1/2 x 5/8	73,5 x 9 x 1,5	1
08	28 7/8 x 3 1/2 x 5/8	73,5 x 9 x 1,5	1
10	29 1/2 x 13 1/2 x 1/8	74,9 x 34,2 x 0,3	2
11	5 1/8 x 30 1/8 x 5/8	13 x 76,5 x 1,5	1
12	18 1/8 x 5 1/8 x 5/8	45,9 x 13 x 1,5	2
14	14 1/4 x 26 3/8 x 5/8	36,2 x 67 x 1,5	2

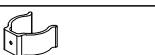
PARTS IDENTIFICATION
IDENTIFICAÇÃO DAS PEÇAS / IDENTIFICACIÓN DE LAS PIEZAS

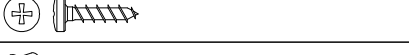

IDENTIFICATION OF ACCESSORIES IDENTIFICAÇÃO DOS ACESSÓRIOS/ IDENTIFICACIÓN DE ACCESORIOS

A		Flanged head screw / Parafuso flangeado / Tornillo de cabeza flangeada	5,0x60 mm	2
B3		Bushing / Bucha expansiva / Tapón	8x50 mm	2
C1		Metal claw / Garra de metal / Garra metal	-	4
E		Wooden dowel / Cavilha / Taquete	8x30 mm	12
F13		Handle / Puxador Perfil 700T / Tirador	363 mm	2
G		Structural screw / Parafuso estrutural / Tornillo estructural	5,0x50 mm	10
H		Allen key / Chave allen / Liave allen	3 mm	1
I		Structural screw cover/Tampa parafuso estrutural/Tapa tornillo estructural	-	10
L1		Flat head screw / Parafuso chato / Tornillo de cabeza plana	7,0x40 mm	4
L3		Plastic Foot / Sapata / Pie Plástico	-	4
M		Bore patch adhesive / Tapa furo adesivo / Tapones adhesivo	-	4
M1		Flat head screw / Parafuso chato / Tornillo de cabeza plana	3,5x25 mm	4
M12		Metal hinge super high / Dobradiça super alta / Bisagra alta	35 mm	4
N		Nail / Pregó / Clavo	10x10	32
N4		Loop / Presilha / Presilla	-	6
N5		Support "L" / Suporte "L" / Soporte "L"	-	2
N6		Cover / Capa / Cubierta	-	2
N7		Wooden dowel / Cavilha / Taquete	8x20 mm	4
Q4		Flat head screw / Parafuso chato / Tornillo de cabeza plana	4,5x60 mm	2
S		Pan head screw / Parafuso panela / Tornillo de pan	3,5x14 mm	40
Z		Plastic hole plugs / Tapa furo plástico / Tapones plásticos	8 mm	4



PRE-ASSEMBLE
PRÉ-MONTAGE / PRE ARMADO

01

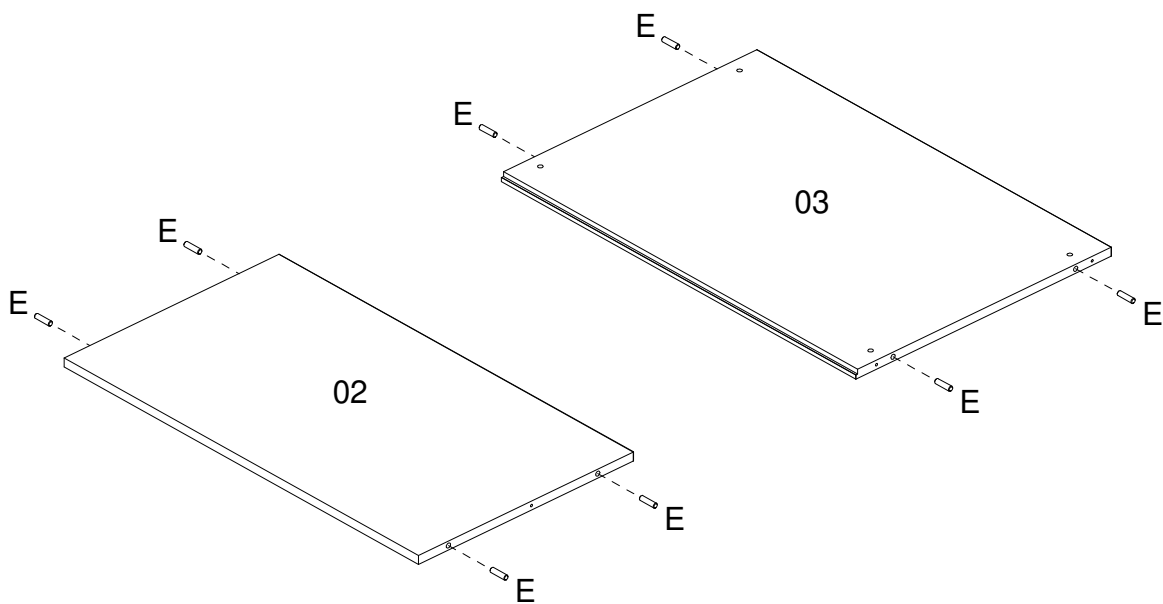
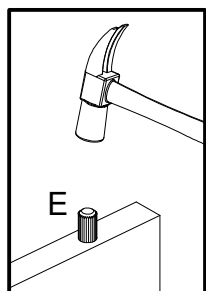

02

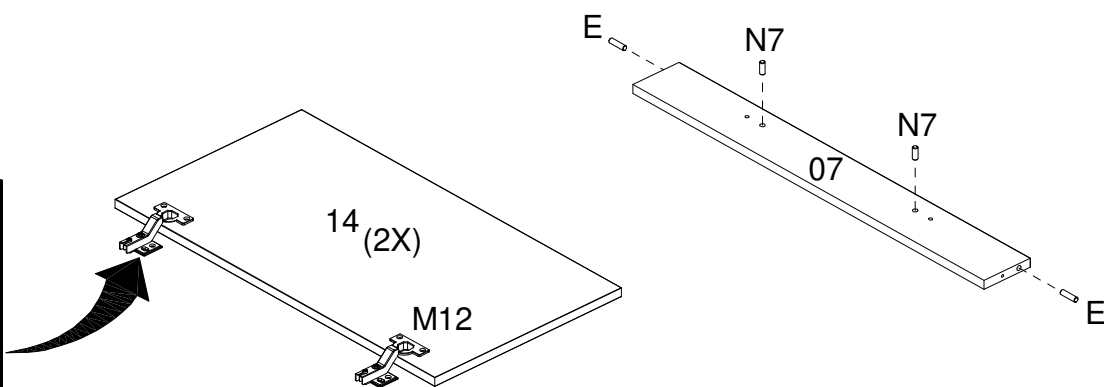
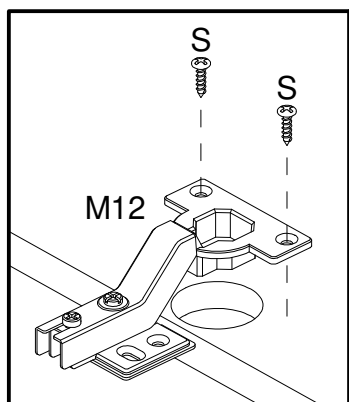

03

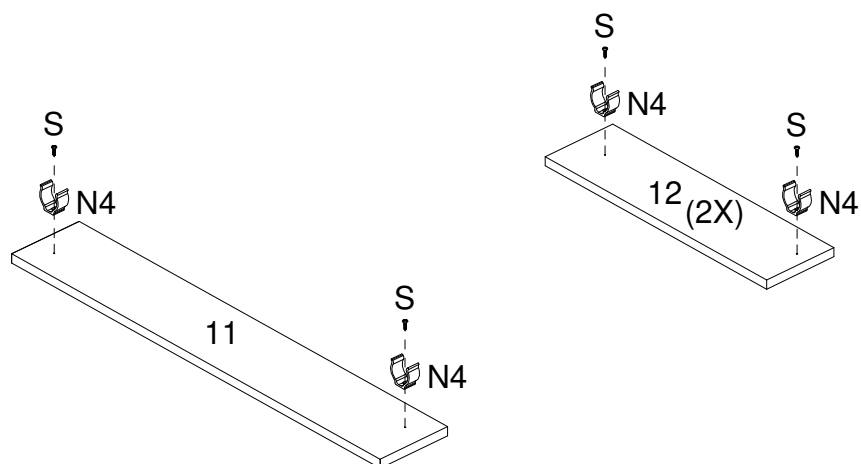

04

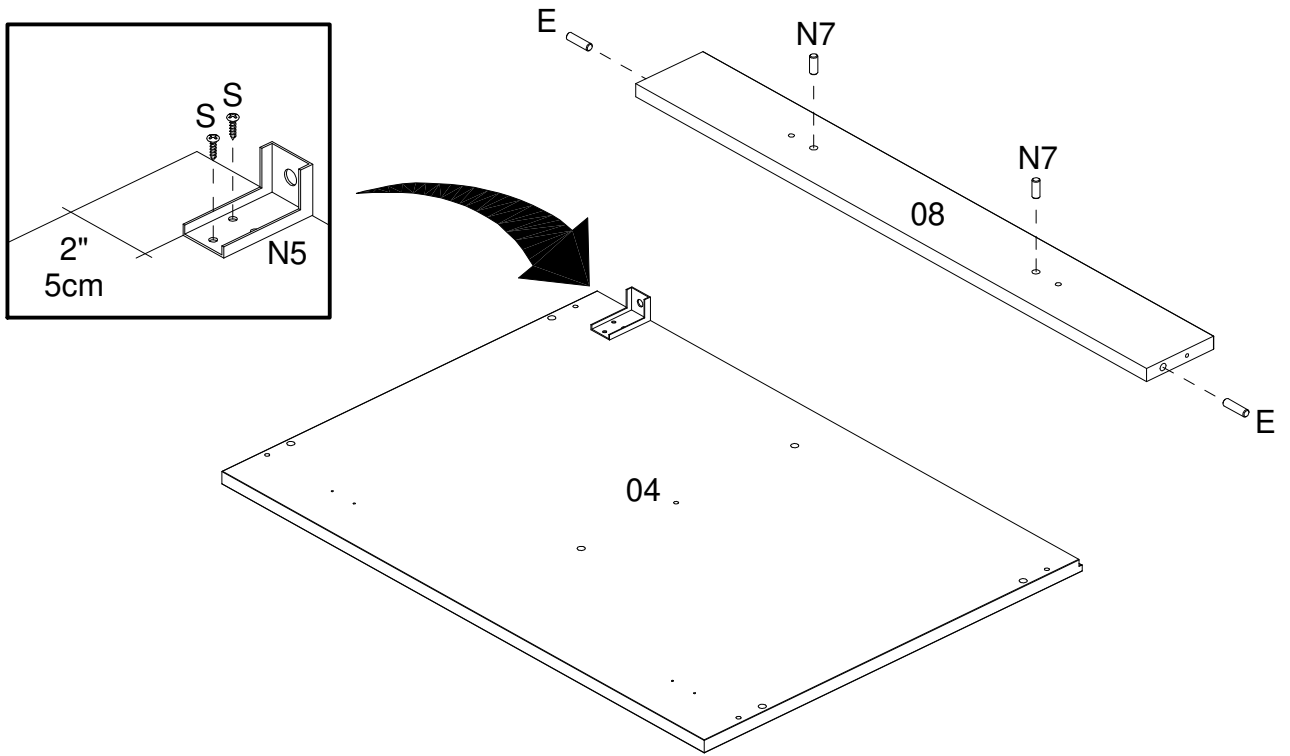

05

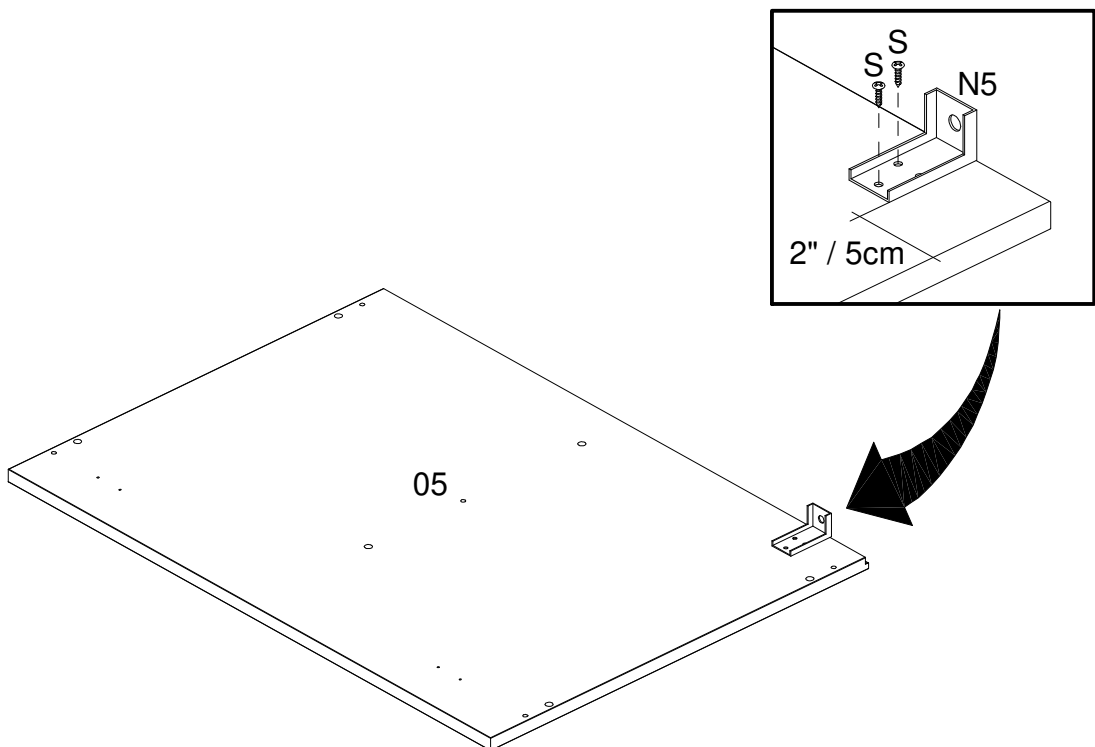

ASSEMBLY
MONTAGEM / ARMADO

06

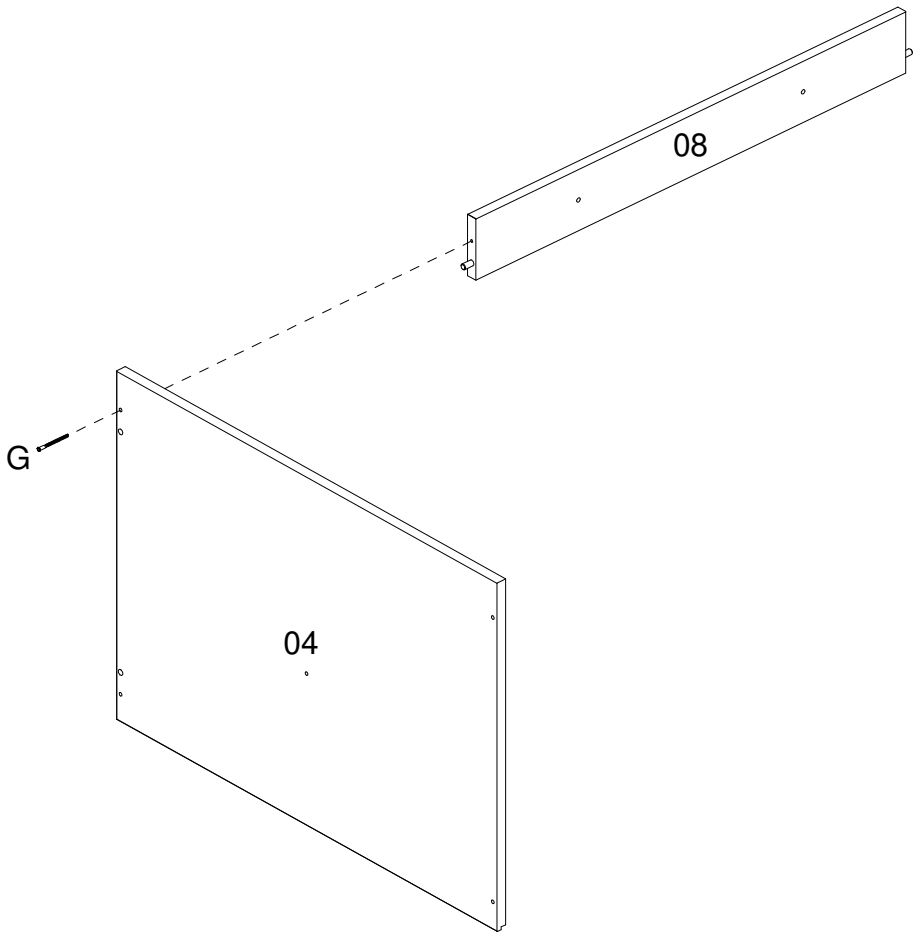
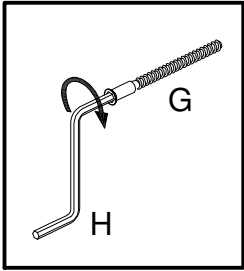

07

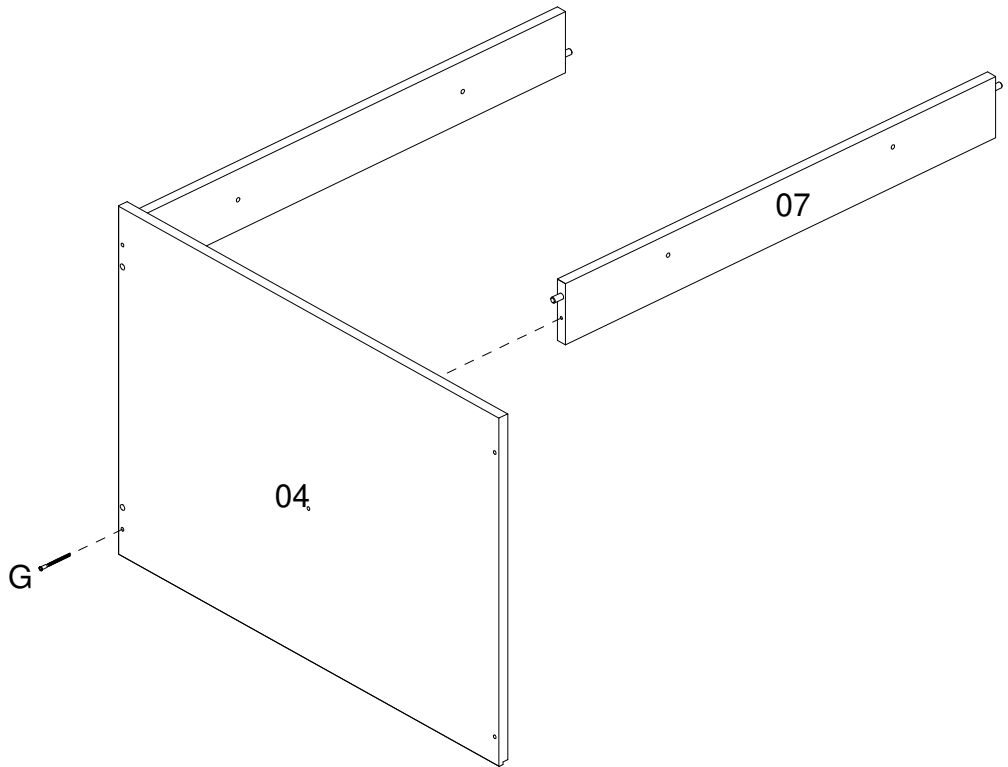

08

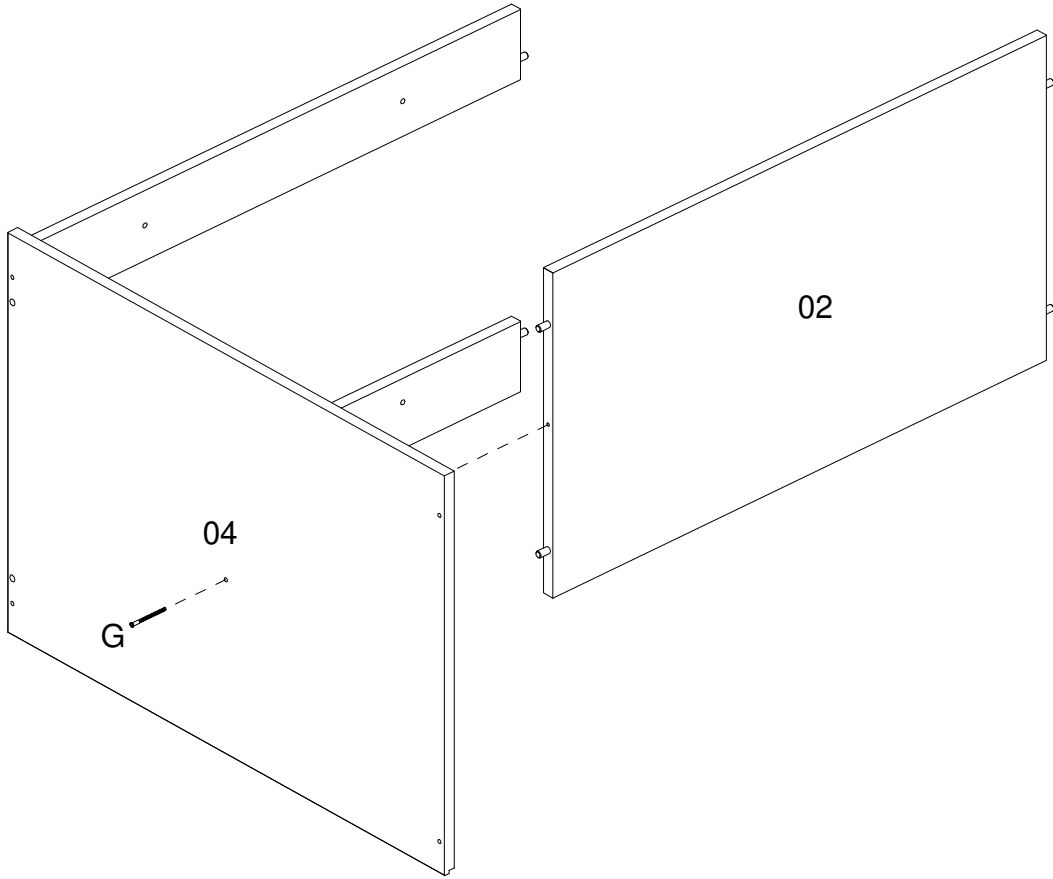

09

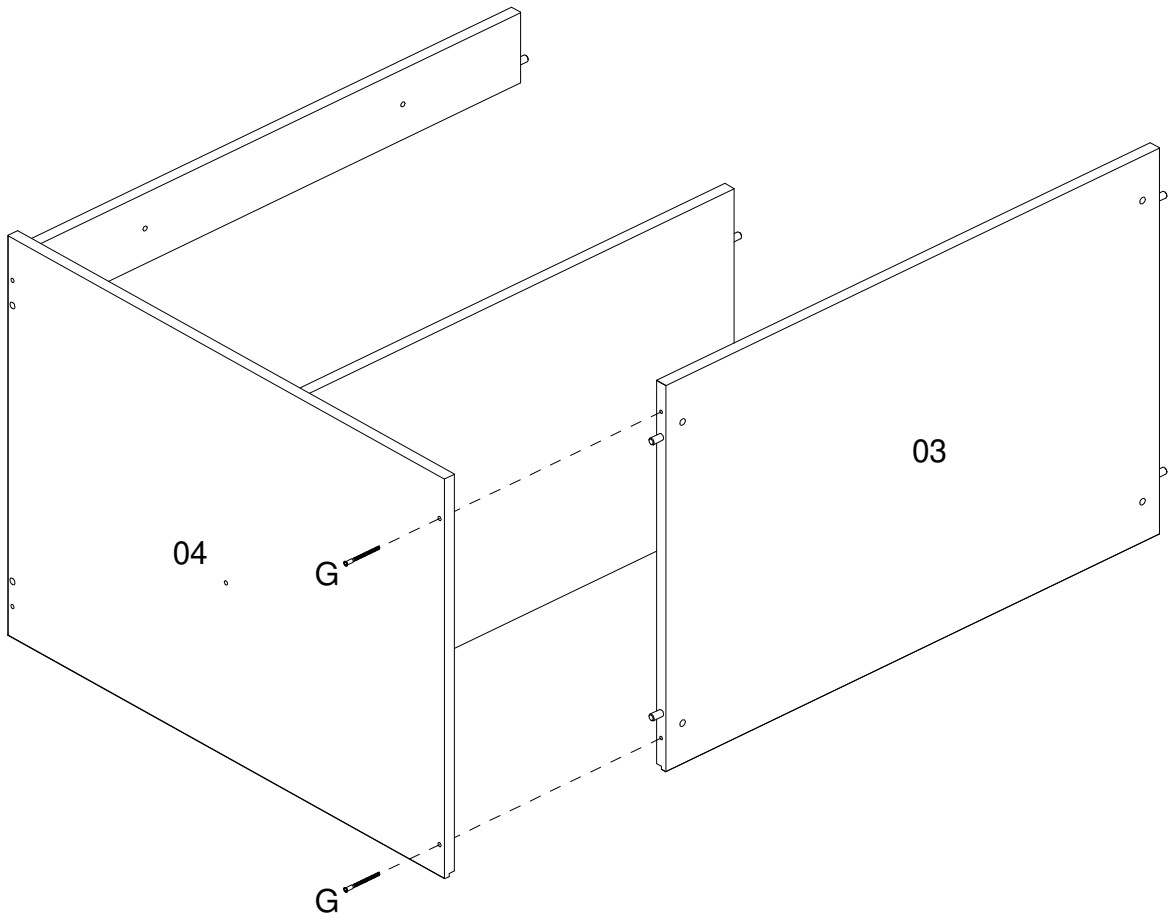

10

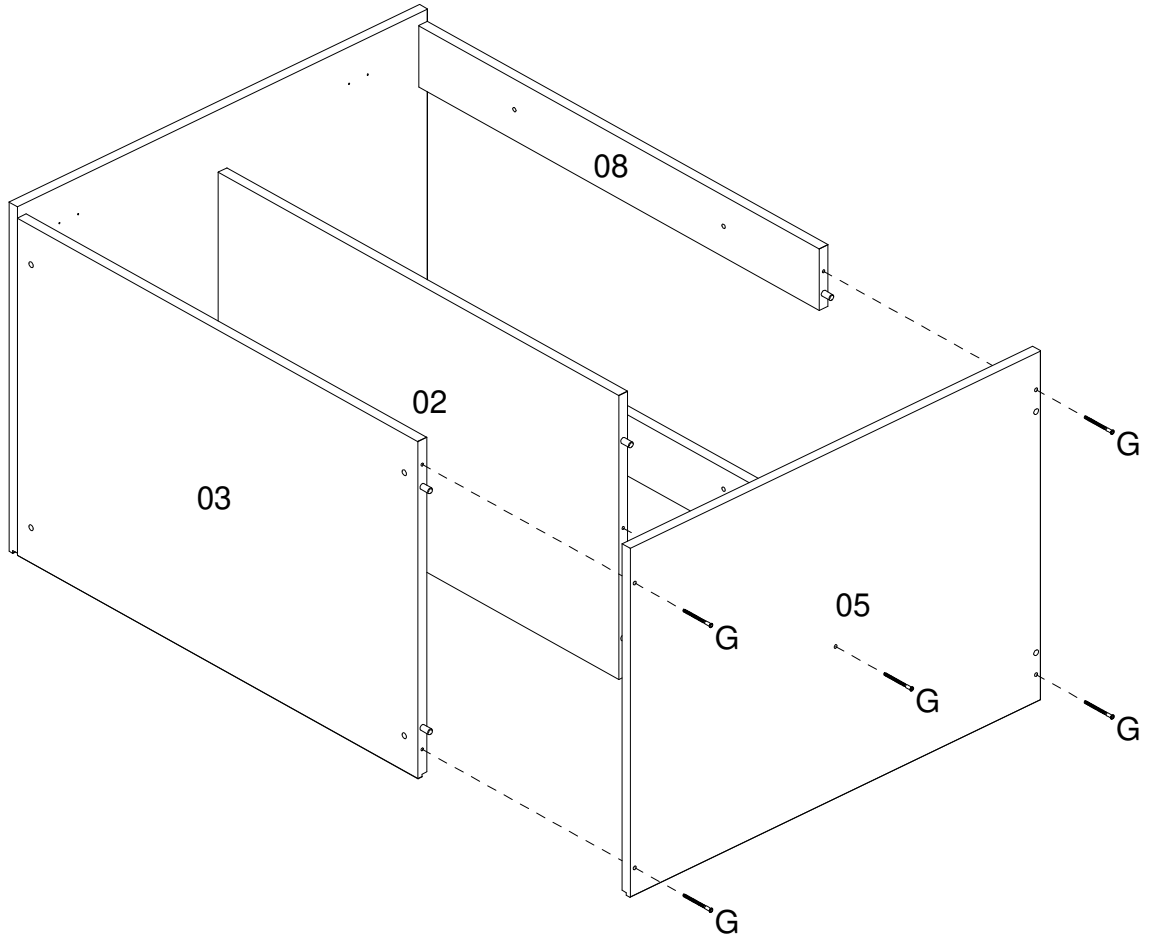

11

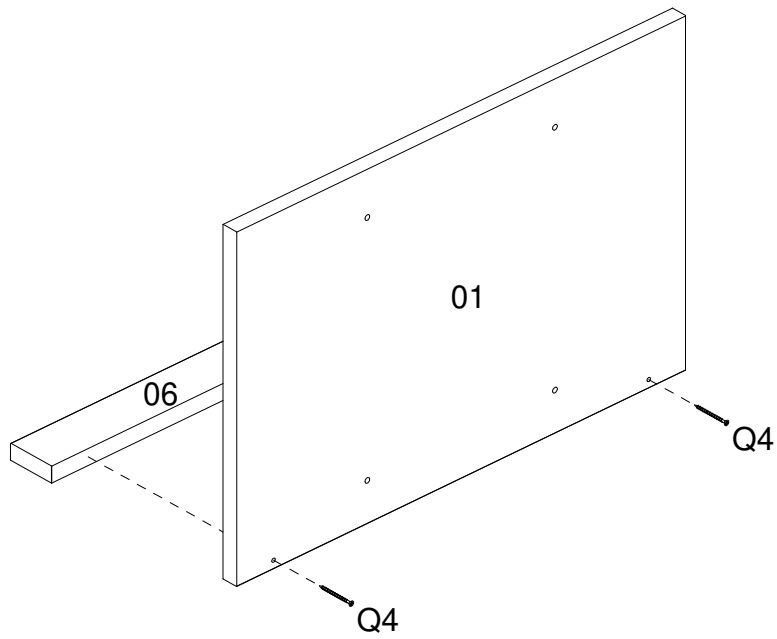

12

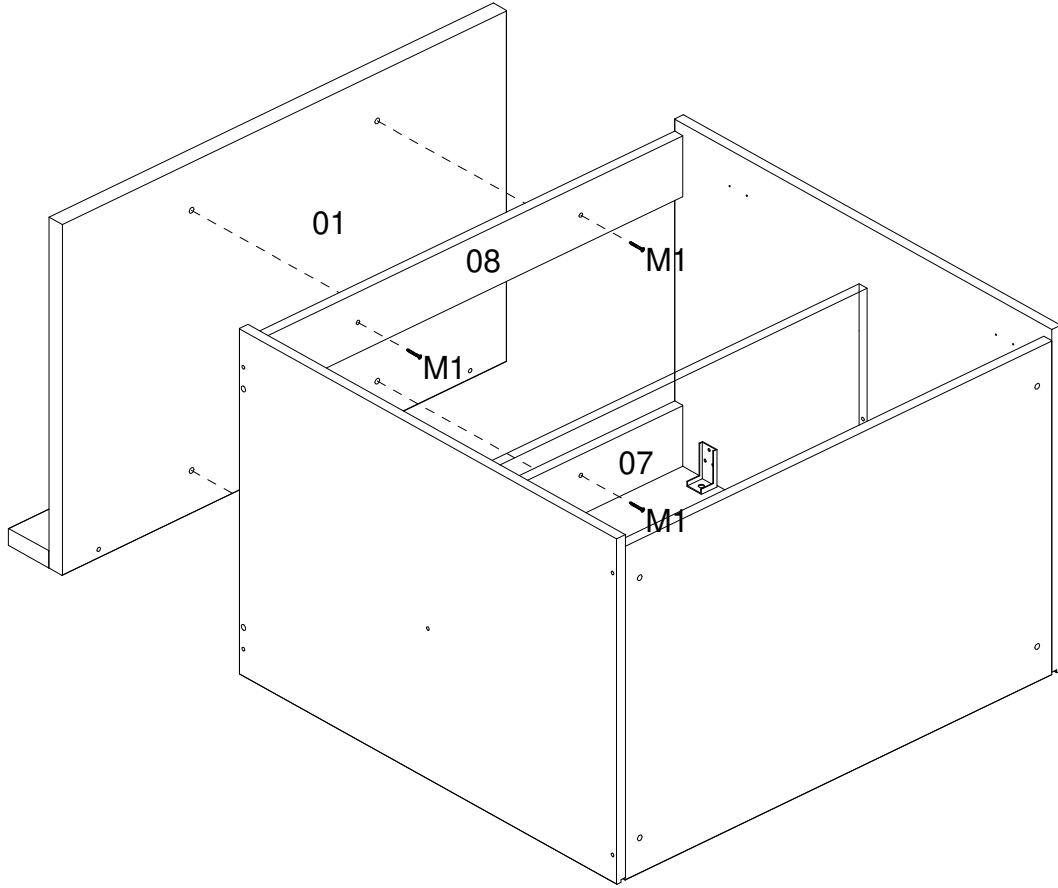

13

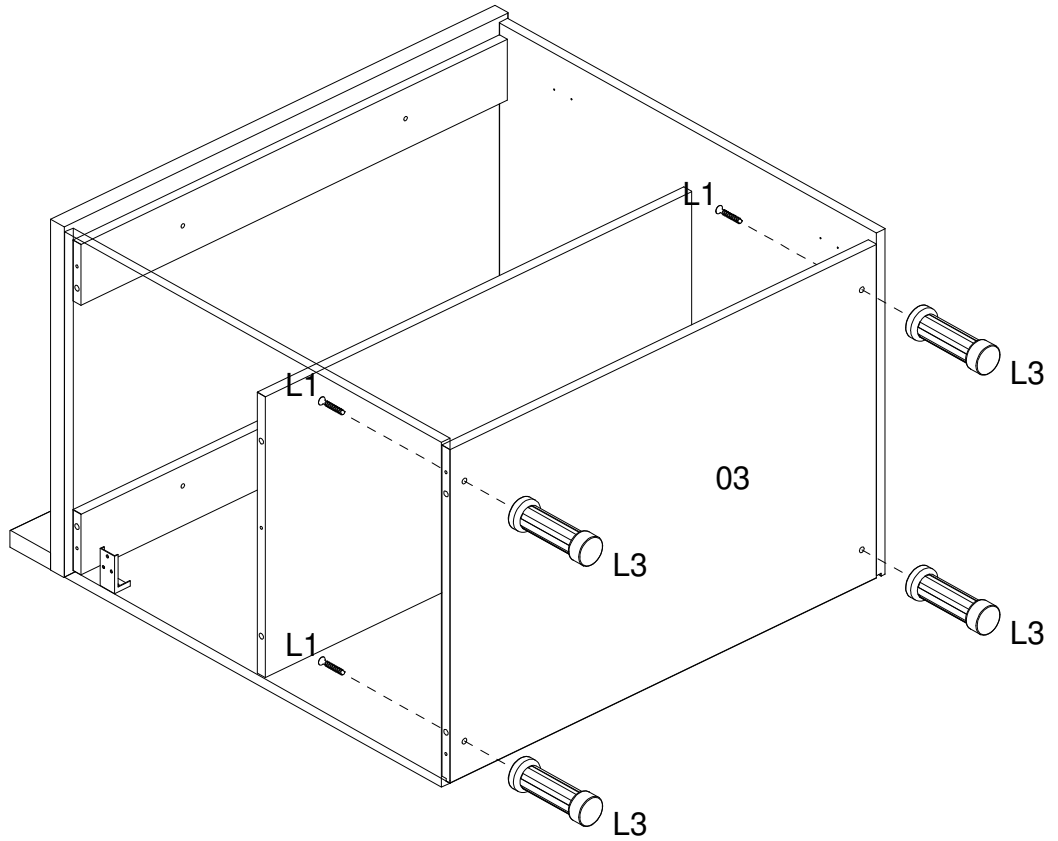

14

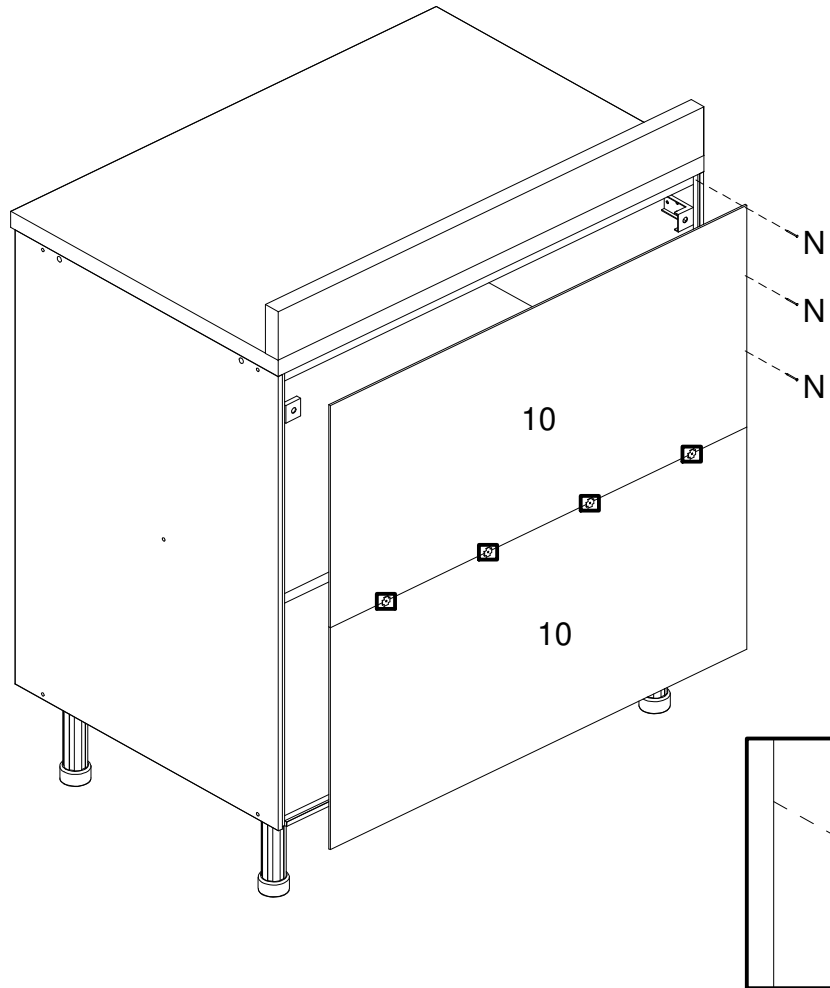

15

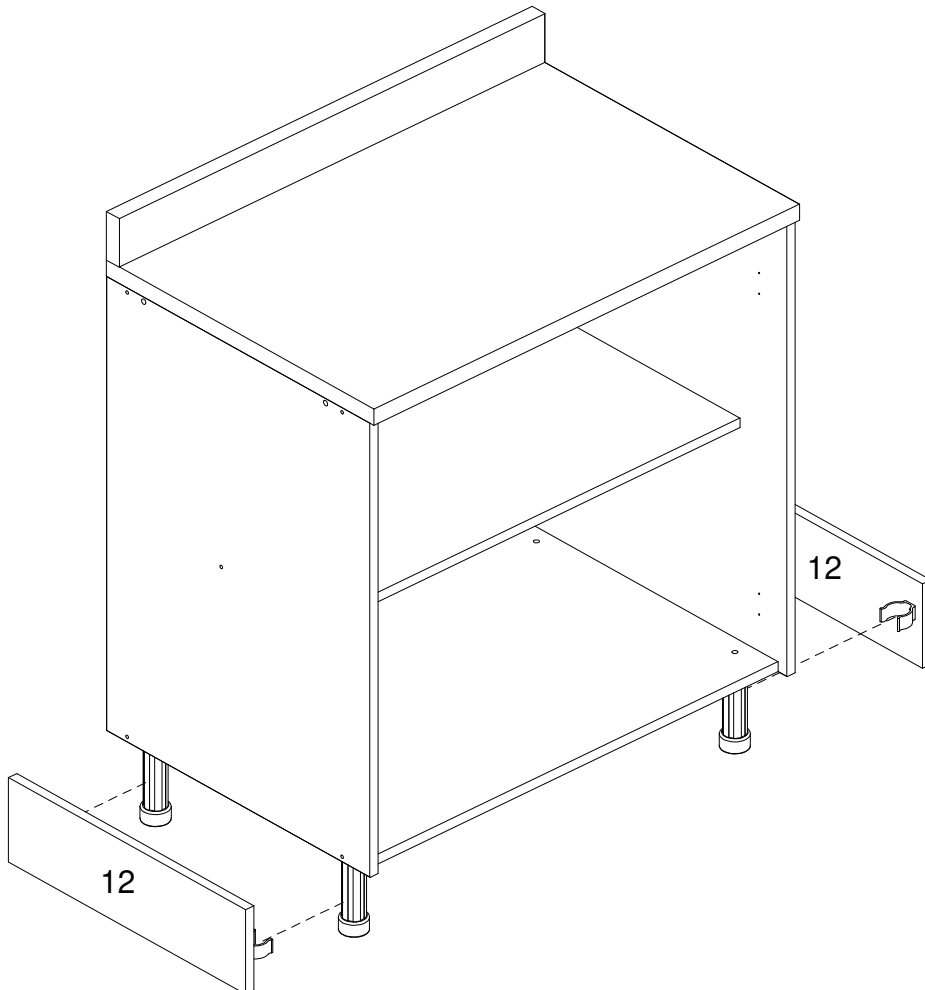

16

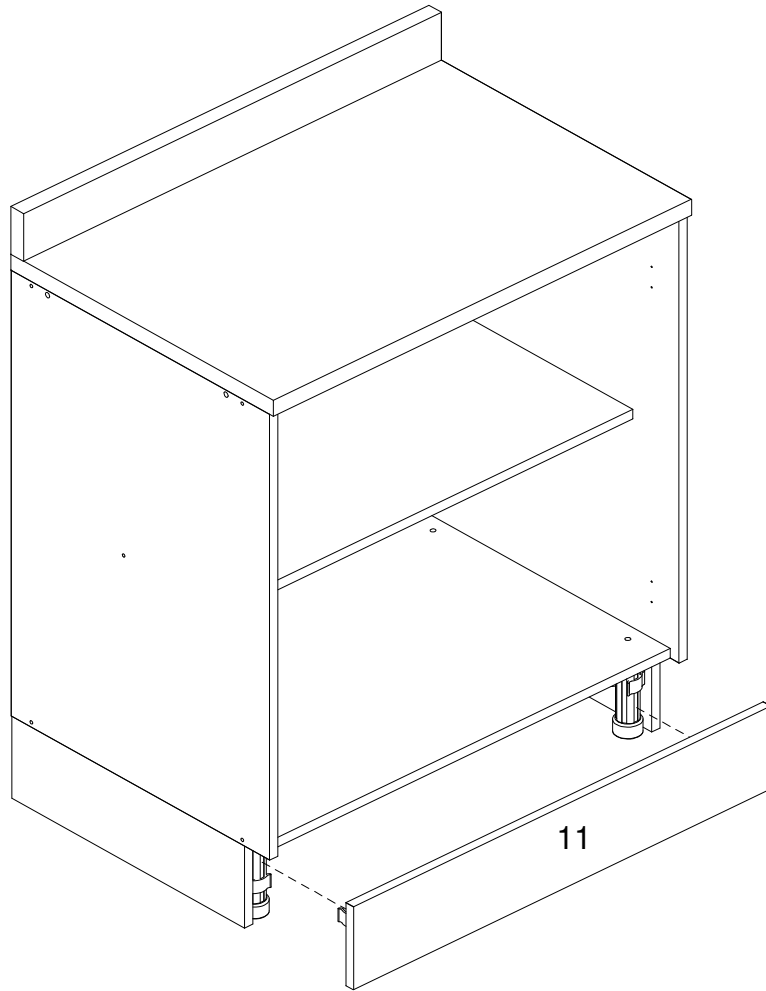

17

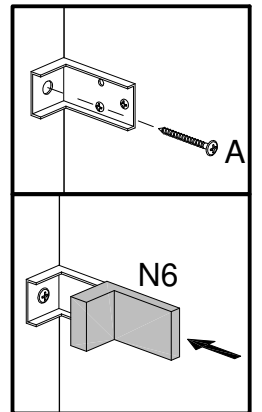
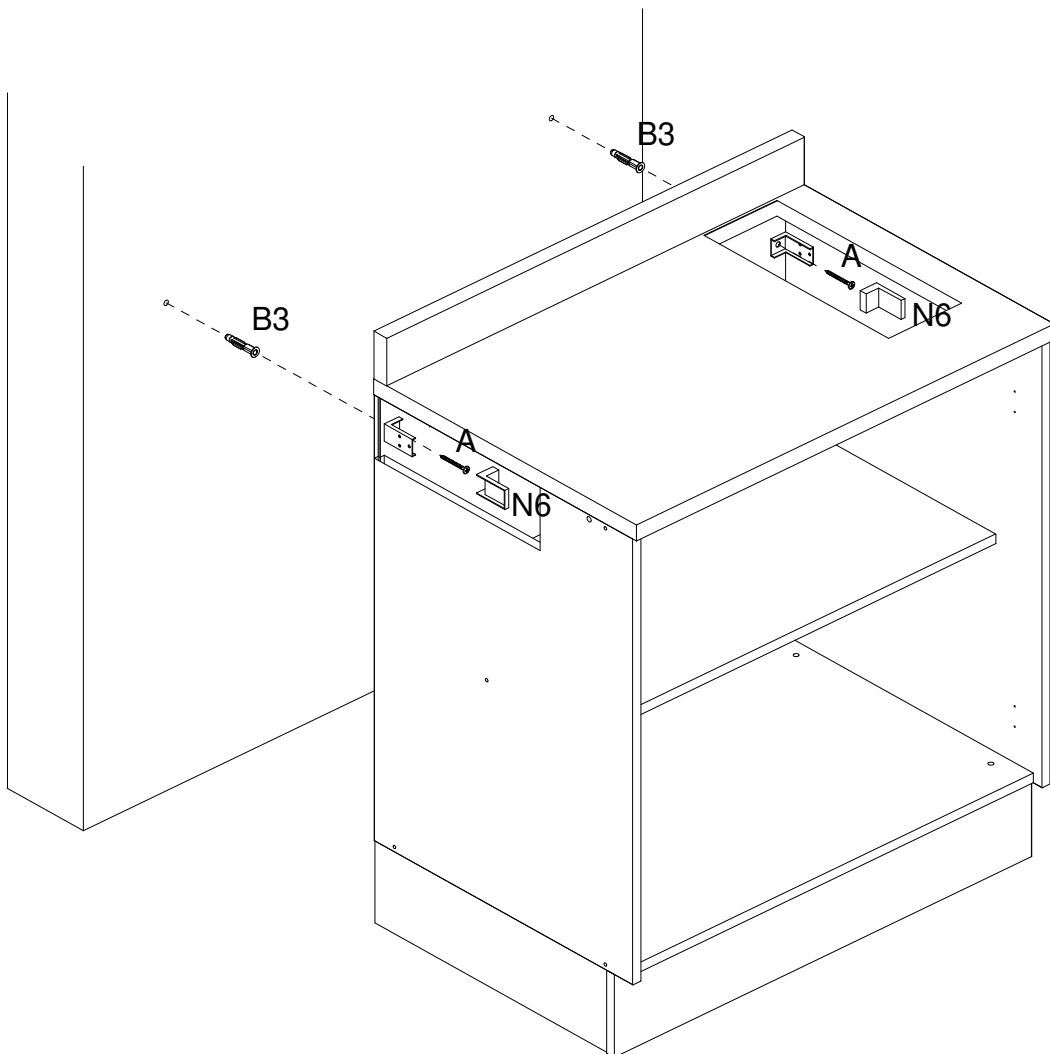

18

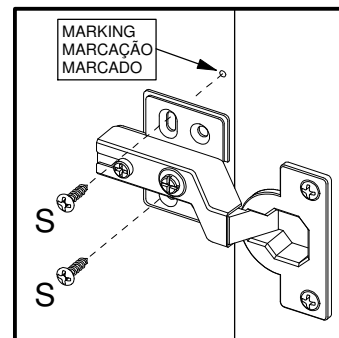
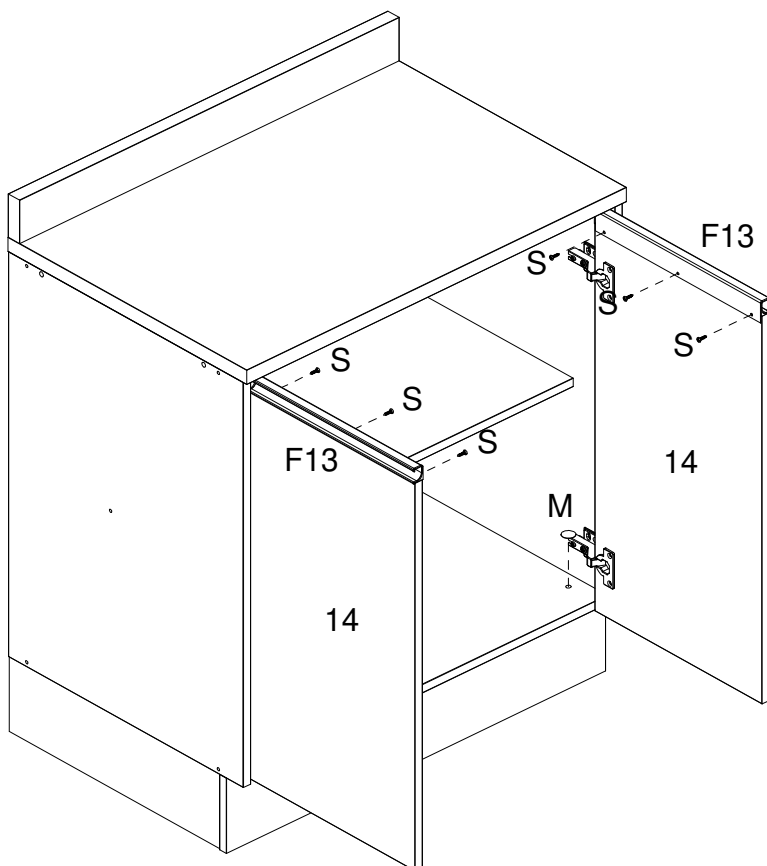

19

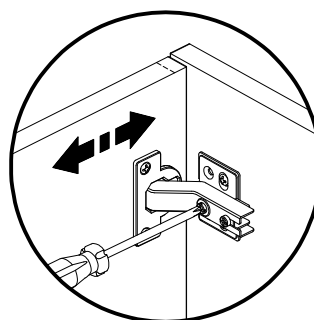
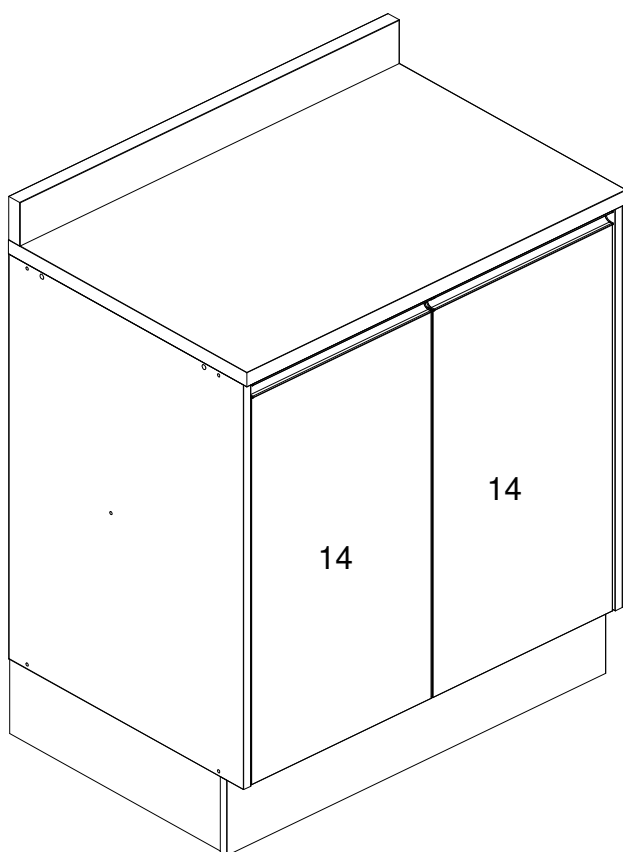

Horizontal Adjustment
Regulagem Horizontal
Ajuste Horizontal

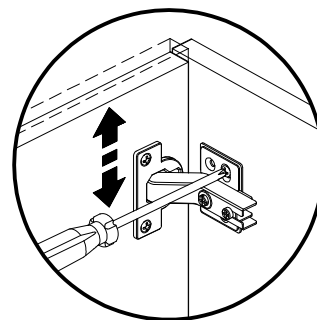

Vertical Adjustment
Regulagem Vertical
Ajuste Vertical

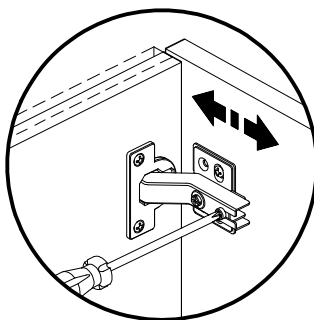

Depth Adjustment
Regulagem Profundidade
Ajuste Profundidad

