

PANELEIRO IARA

REF.: 667

MANUAL DE MONTAGEM / ASSEMBLY MANUAL / MANUAL DE MONTAJE

Centralizar o puxador
Center the handle
Centrar el mango

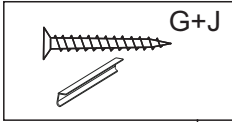

Para o puxador não se movimentar
pode ser utilizado cola instantânea para melhorar a fixação
entre a fita de borda e o puxador.

To prevent the handle from moving
instant glue can be used to improve fixation
between the edge band
and the handle.

Para evitar que el mango se mueva
Se puede utilizar pegamento instantáneo para mejorar la fijación.
entre el borde y el mango.

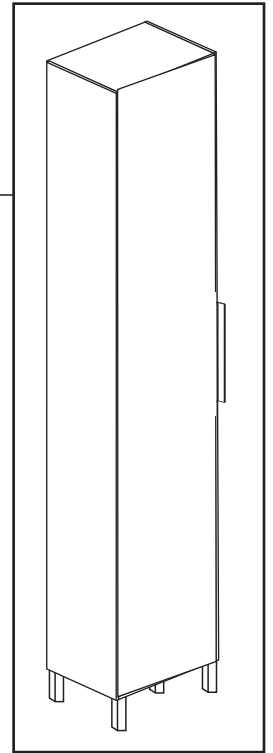

FERRAGENS / HARDWARE / EQUIPOS

A		Parafuso 4 x 40 Screw 4 x 40 Tornillo 4x40
B		Prego 10 x 10 Nail 10 x 10 Clavo 10 x 10
D		PÉS FEET PIES
F		Bucha Bushing Cojinete
G		Puxador Handle Manejar
I		Dobradiça Hinge Bisagra
J		Parafuso 3,5 x 14 Screw 3,5 x 14 Tornillo 3,5x14
K		Suporte Support Apoyo
M		Parafuso 5 X 50 Screw 5 x 50 Tornillo 5 x50
L		Suporte Parede Wall Support Soporte de pared

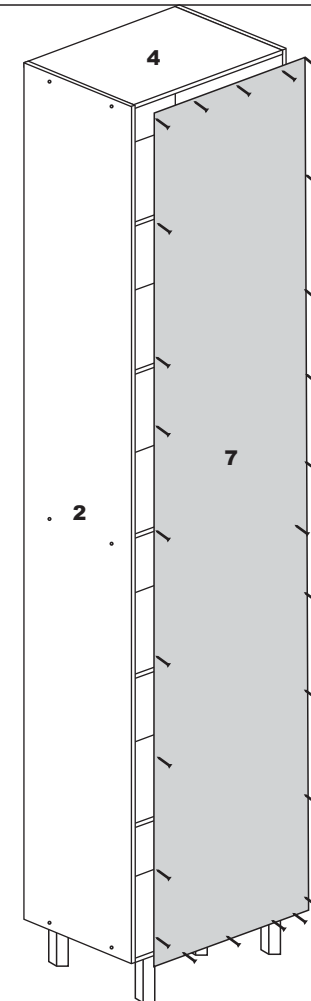
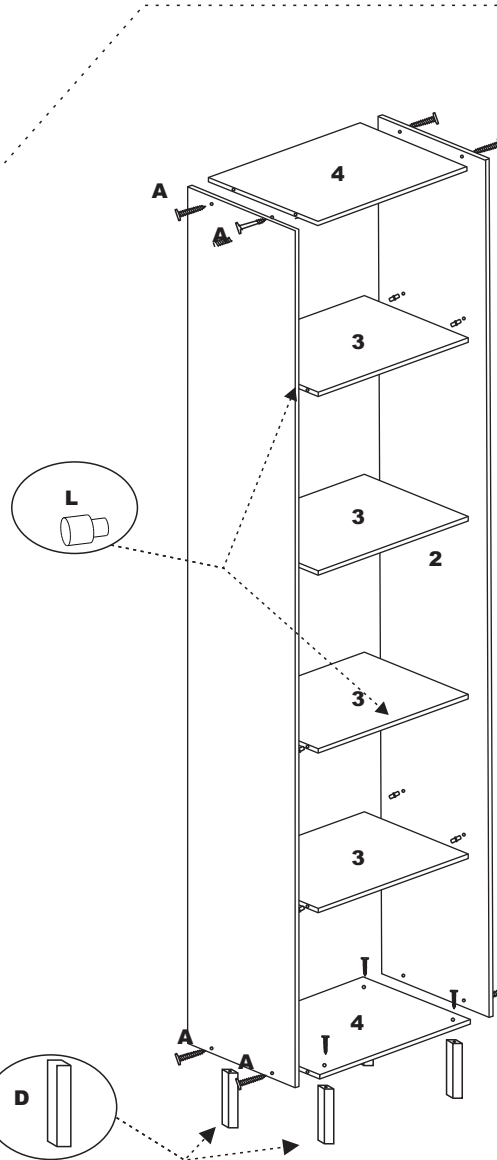
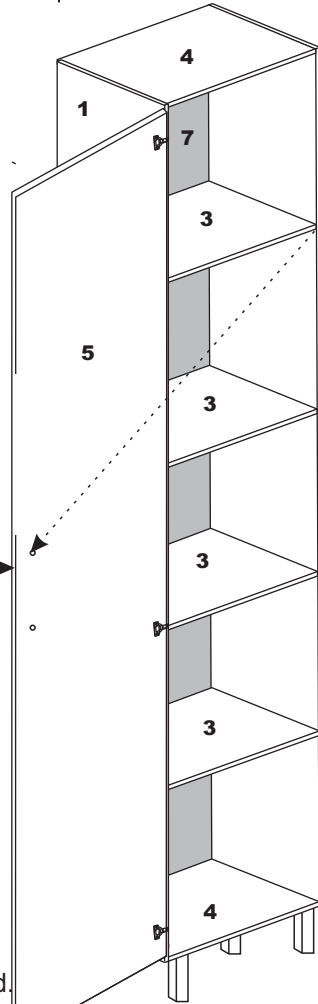

If you require any type of assistance
technique, have this assembly diagram at hand.

Si requieres algún tipo de asistencia
técnica, tenga a mano este esquema de montaje.

Em caso de solicitação de algum tipo de assistência
técnica, tenha este esquema de montagem em mãos.

BALCÃO DE PIA IARA

REF.: 649

MANUAL DE MONTAGEM ASSEMBLY INSTRUCTIONS INSTRUCCIONES DE MONTAJE

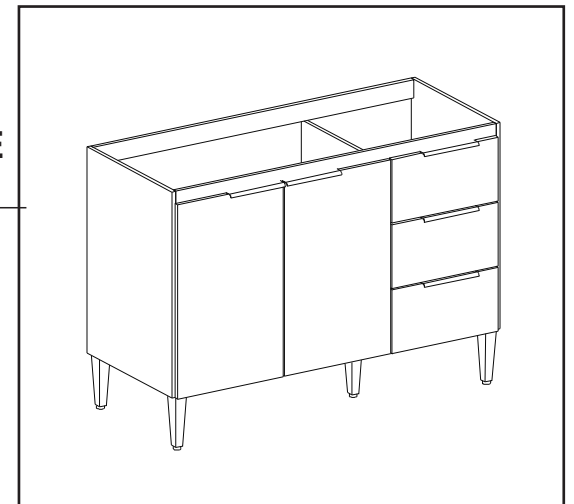

1° PASSO
1° STEP
1° PASO

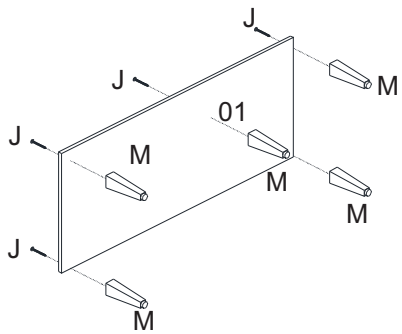

2° PASSO
2° STEP
2° PASO

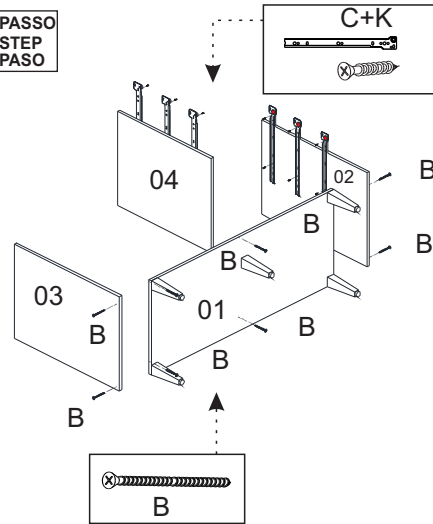

3° PASSO
3° STEP
3° PASO

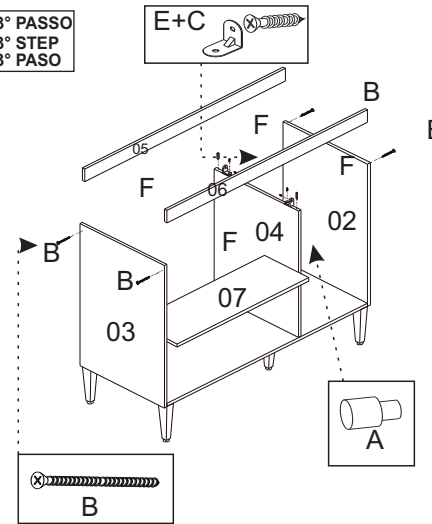

4° PASSO
4° STEP
4° PASO

3X

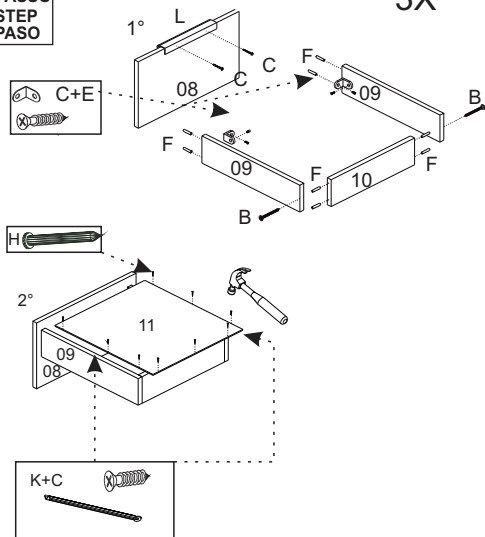

5° PASSO
5° STEP
5° PASO

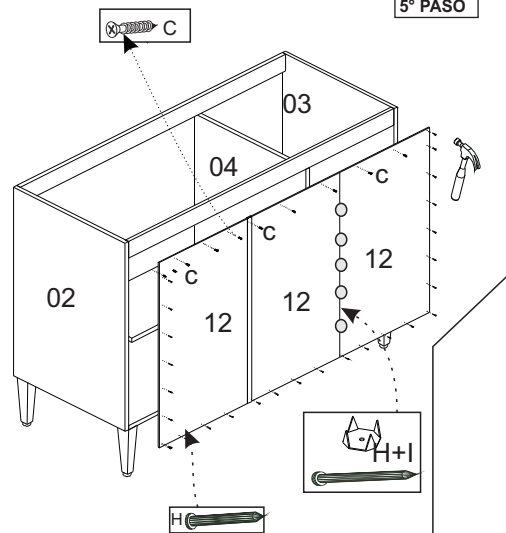

6° PASSO
6° STEP
6° PASO

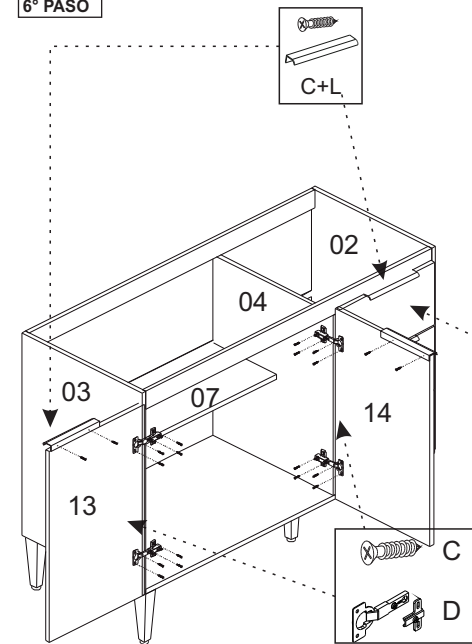

FERRAGENS / HARDWARE / EQUIPOS

A	04	SUPORE PINO PIN SUPPORT SOPORTE DE PIN	
B	17	PARAFUSO 4 X 40 SCREW 4 X 40 TORNILLO 4 X 40	
C	82	PARAFUSO 3,5 X 14 SCREW 3,5 X 14 TORNILLO 3,5X14	
D	04	DOBRADIÇA SUPER ALTA 26 SUPER HIGH HINGE 26 BISAGRA SUPER ALTA 26	
E	09	CANTONEIRA CORNER ESQUINA	
F	28	CAVILHA 6 X 30 6 X 30 DOWEL CLAVIJA 6 X 30	
G	01	PERFIL H PROFILE H PERFIL H	
H	40	PREGO 10 X 10 NAIL 10 X 10 CLAVO 10 X 10	
I	06	FIXADOR DE FUNDO BOTTOM FIXER FIJADOR INFERIOR	
J	05	PARAFUSO 5 X 40 SCREW 5 X 40 TORNILLO 5 X40	
K	03	TRILHO METAL SLIDE DESLIZAR	
L	05	PUXADOR HANDLE MANEJAR	
M	05	SAPATA SHOE	

Para o puxador não se movimentar
pode ser utilizado cola instantânea para melhorar a fixação
To prevent the handle from moving
instant glue can be used to improve fixation
Para evitar que el mango se mueva
Se puede utilizar pegamento instantáneo para mejorar la fijación.

BALCÃO COOKTOP 5 BOCAS

REF.: 517

MANUAL DE MONTAGEM
ASSEMBLY INSTRUCTIONS
INSTRUCCIONES DE MONTAJE

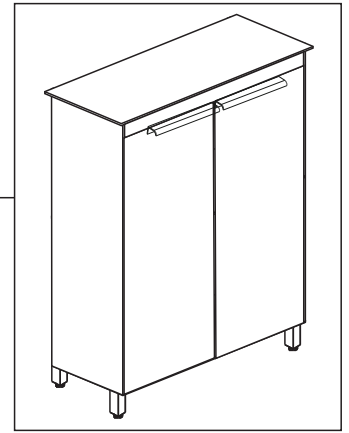

FERRAGENS HARDWARE EQUIPOS

A		Parafuso 4,5 x 50 SCREW 4 X 50 TORNILLO 4 X 50
B		Prego 10 x 10 NAIL 10 X 10 CLAVO 10 X 10
C		Cavilhas 6 x 30 6 X 30 DOWEL CLAVIJA 6 X 30
D		Sapata SHOE ZAPATO
E		Cantoneira CORNER ESQUINA
G		Puxador HANDLE MANEJAR
I		Dobradiça HINGE BISAGRA
J		Parafuso 3,5 x 14 SCREW 3.5 X 14 TORNILLO 3,5X14
L		Perfil H PROFILE H PERFIL H
M		Suporte Pino Pin Support Soporte de pasador

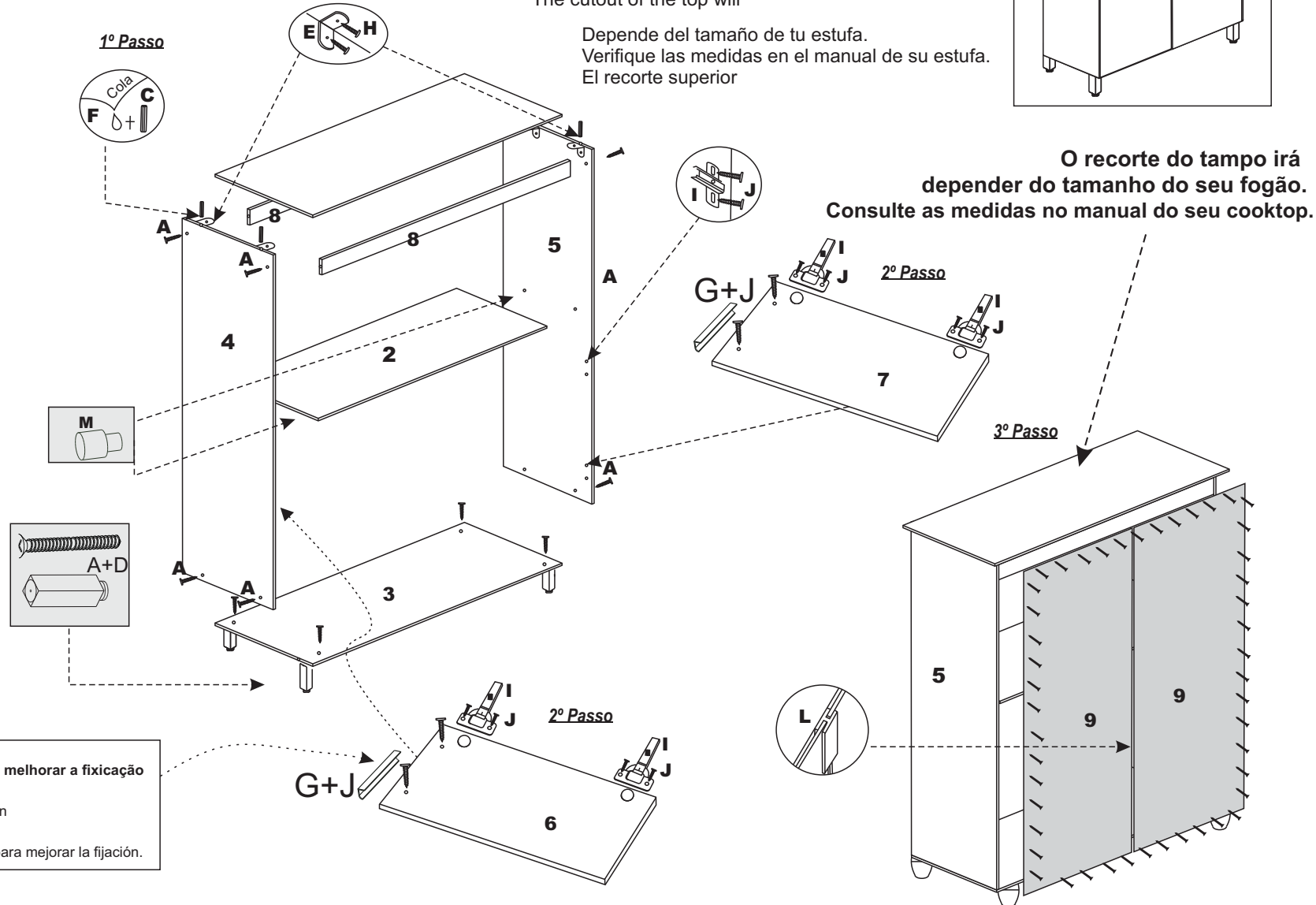

TORRE QUENTE IARA

REF.: 6661

MANUAL DE MONTAGEM / ASSEMBLY MANUAL / MANUAL DE MONTAJE

FERRAGENS / HARDWARE / EQUIPOS

A		Parafuso 4 x 40 Screw 4 x 40 Tornillo 4x40
B		Prego 10 x 10 Nail 10 x 10 Clavo 10 x 10
C		Cavilhas 6 x 30 6 X 30 DOWEL CLAVIJA 6 X 30
D		Pé FEET PIES
E		Cantoneira Corner guard Esquina
F		Puxador Handle Manejar
G		Dobradiça Hinge Bisagra
H		Parafuso 3,5 x 14 Screw 3,5 x 14 Tornillo 3,5x14
J		Perfil H Per?l H Por lo H
K		Suporte Support Apoyo
L		Parafuso 5 X 40 Screw 5 x 40 Tornillo 5 x40

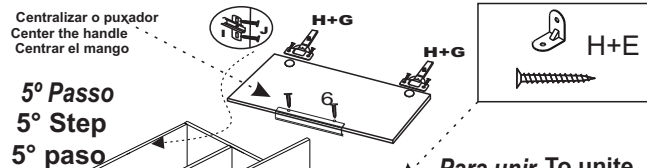
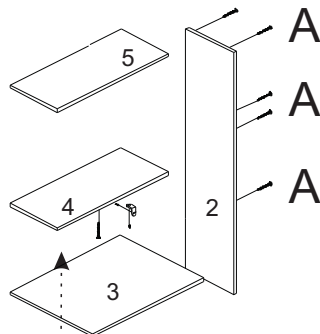
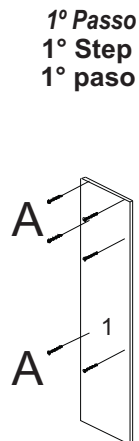

Para unir To unite
para unir

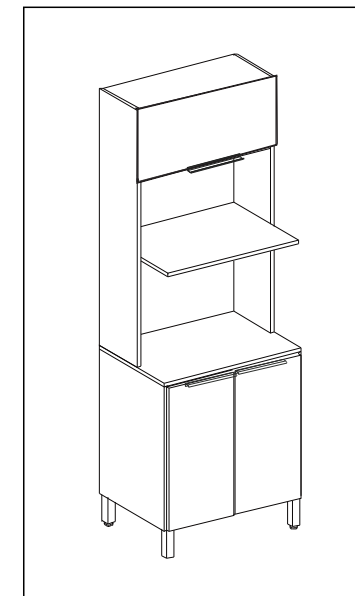

Para o puxador não se movimentar
pode ser utilizado cola instantânea para melhorar a fixação
entre a fita de borda e o puxador.

To prevent the handle from moving
instant glue can be used to improve fixation
between the edge band and the handle.

Para evitar que el mango se mueva
Se puede utilizar pegamento instantáneo para mejorar la fijación.
entre el borde y el mango.

2° Passo
2° Step
2° paso

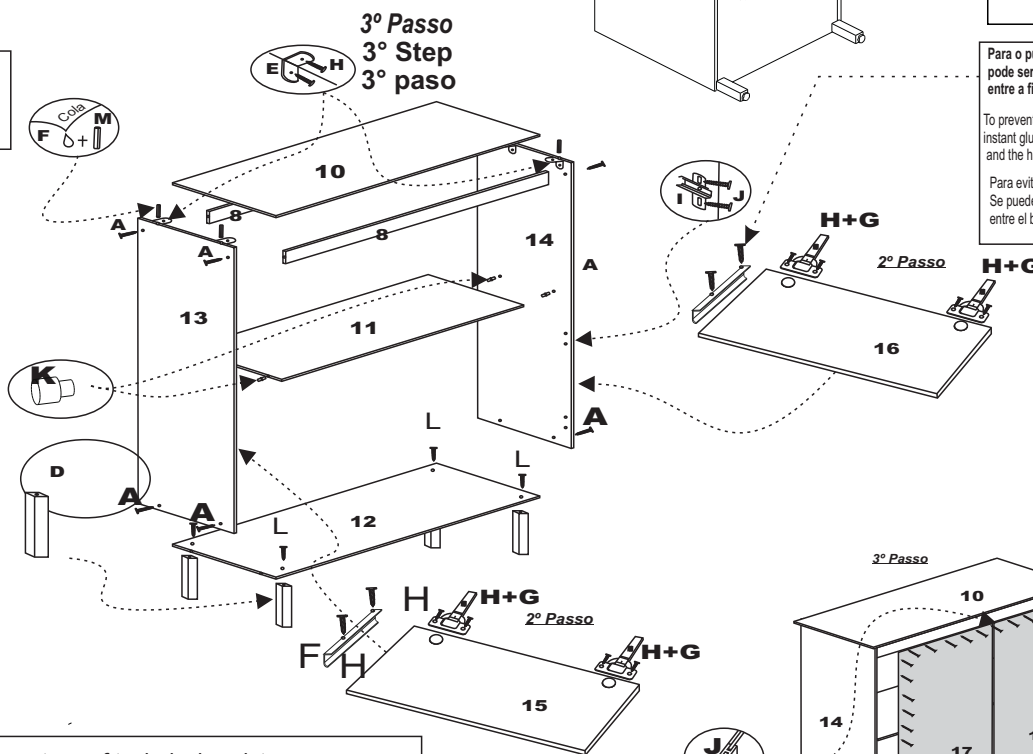
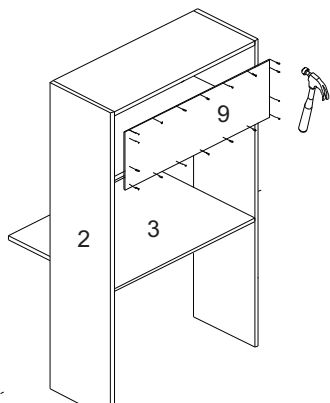

Em caso de solicitação de algum tipo de assistência técnica, tenha este esquema de montagem em mãos.

If you require any type of technical assistance, have this assembly diagram at hand.

Si requieres algún tipo de asistencia técnica
tenga a mano este esquema de montaje.

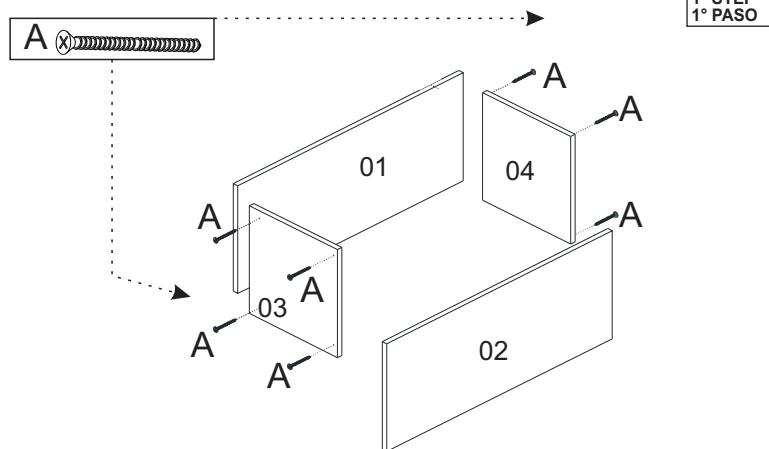
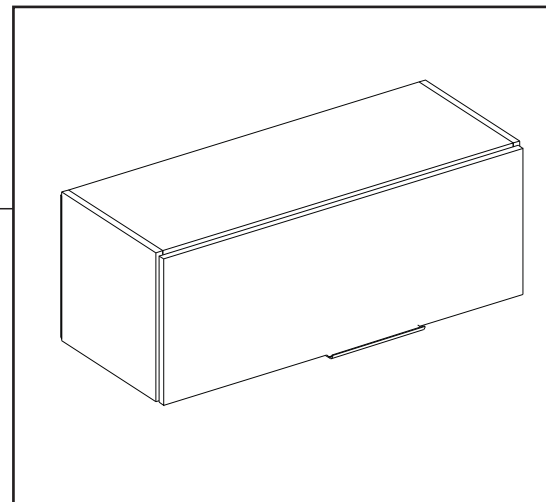

1° PASSO
1° STEP
1° PASO

2° PASSO
2° STEP
2° PASO

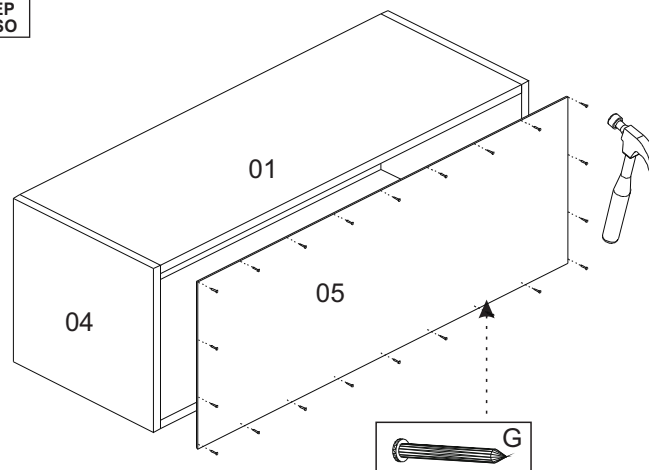

3° PASSO
3° STEP
3° PASO

4° PASSO
4° STEP
4° PASO

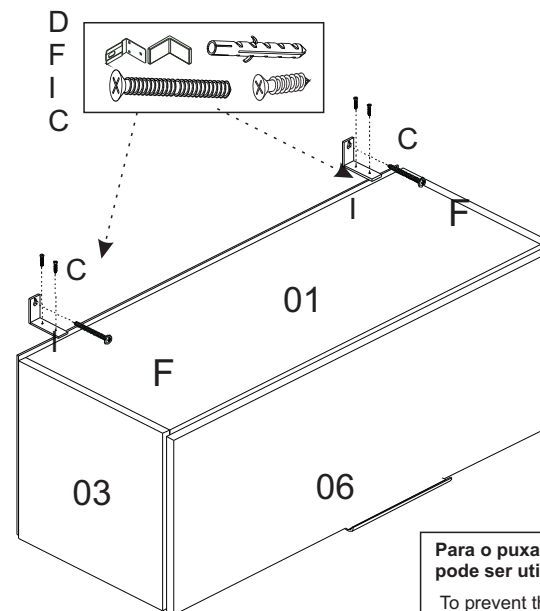
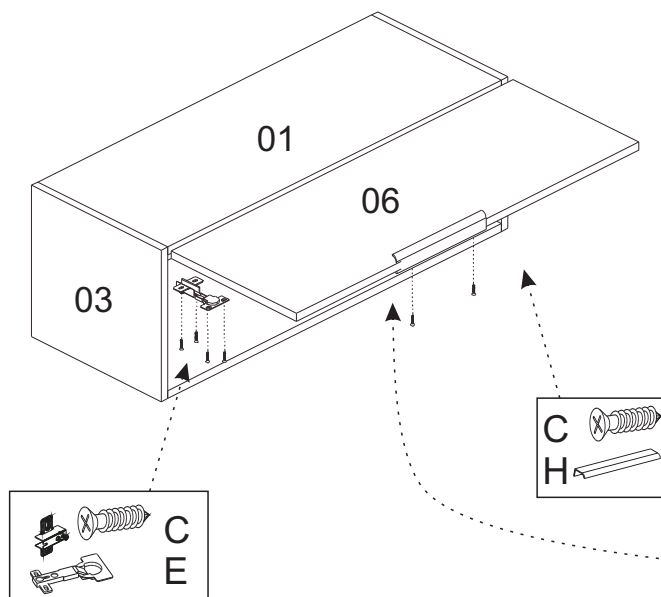

FERRAGENS HARDWARE EQUIPOS

Letter	Quantity	Description	Image
A	08	PARAFUSO 4 X 40 SCREW 4 X 40	
C	17	PARAFUSO 3,5 X 14 SCREW 3,5 X 14 TORNILLO 3,5X14	
D	02	BUCHA BUSH COJINETE	
E	02	DOBRADIÇA SUPER ALTA 26 SUPER HIGH HINGE 26 BISAGRA SUPER ALTA 26	
F	02	PARAFUSO 5 X 50 SCREW 5 X 50 TORNILLO 5 X50	
G	30	PREGO 10 X 10 NAIL 10 X 10 CLAVO 10 X 10	
H	01	PUXADOR HANDLE MANEJAR	
I	02	SUPORTE AÉREO AIR SUPPORT APOYO AÉREO	







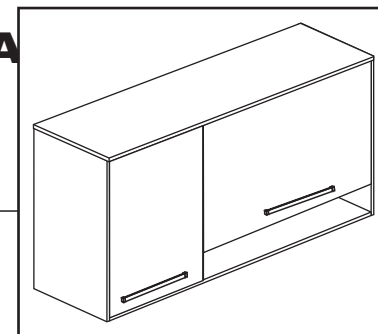

**Para o puxador não se movimentar
pode ser utilizado cola instantânea para melhorar a fixação**

To prevent the handle from moving
instant glue can be used to improve fixation

Para evitar que el mango se mueva
Se puede utilizar pegamento instantáneo para mejorar la fijación.



FERRAGENS

A		Parafuso 4,5 x 50
B		Prego 10 x 10
C		Cavilhas 6 x 30
D		Puxador
E		Parafuso 4 x 25
F		Dobradiça
G		Parafuso 3,5 x 14
H		Parafuso 4,0 x 30

