

Aéreo 01 Porta Basculante 600mm Connect |
Aéreo 01 Puerta Basculante 600mm Connect |
01 air port Tipper 600mm Connect

- C77-35 - Duna/Cristal
- C77-42 - Fendi
- C77-139 - Off White

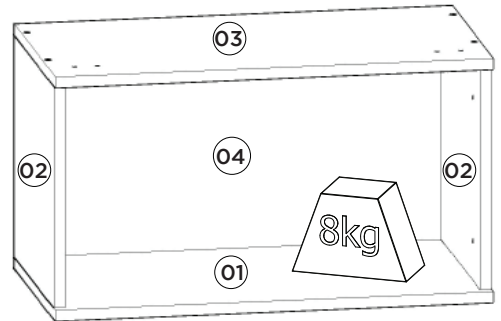
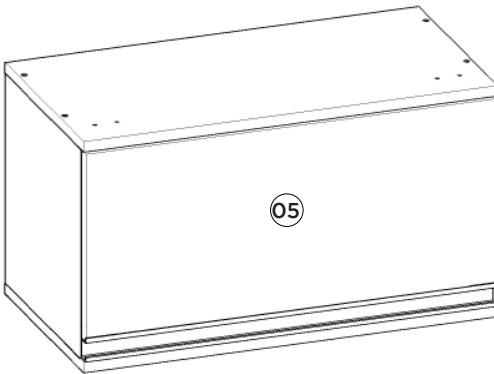

Pesos máximos recomendados com carga distribuída
Peso máximo recomendado con la carga distribuída
Recommended maximum weight with distributed load.

Requisitos para montagem
Requisitos para la montaje
Assembly Requirements

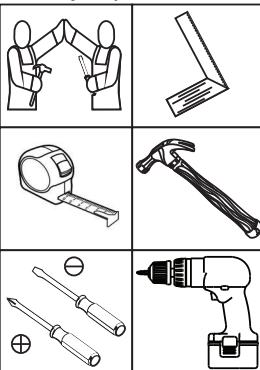

Imagens meramente ilustrativas
Imágenes meramente ilustrativas
Images for illustration only

AVISO

Para limpeza de seu móvel, use uma flanela seca ou umedecida, e não utilize produtos químicos que possam danificar seu produto.

SISTEMA DE MONTAGEM

O sistema de montagem dos produtos, funciona de acordo com a ordem crescente dos números indicados no desenho. Ex: 01, 02, 03, 04... até a conclusão da montagem.

ADVERTENCIA

Para limpieza de su móvil, use una franela seca o húmeda, y no utilice productos químicos que puedan dañar su producto.

SISTEMA DE MONTAJE

El sistema de montaje de los productos funciona de acuerdo con el orden creciente de los números indicados en el dibujo. Ej.: 01, 02, 03, 04... hasta la conclusión del montaje.

NOTICE

To clean your furniture, use a dry or wet cloth, and do not use chemicals that may damage your product.

ASSEMBLY SYSTEM

The products' assembly system works according to the increasing order of the indicated numbers. For example: 01, 02, 03, 04 ... to the end of the assembly.

1

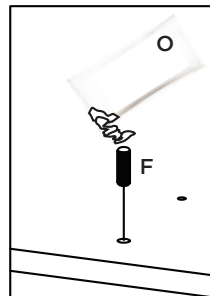
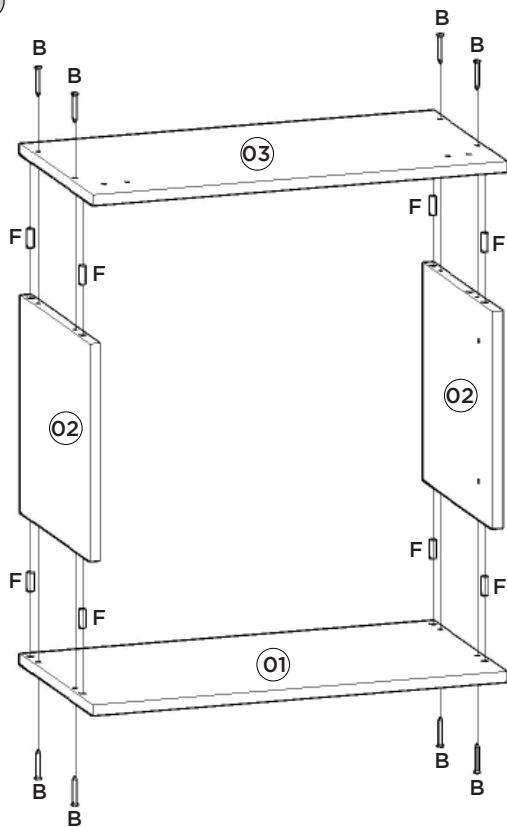

Utilizar o sachê de cola (O) em todas as cavilhas (F) do produto.

Con el pegamento sobre (O) en todos los pernos (F) producto.

Use the glue sachet (O) on all the pegs (F) of the product.

2

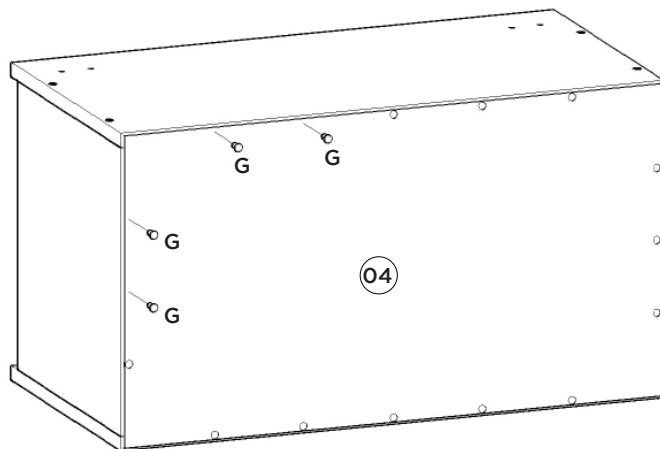

3

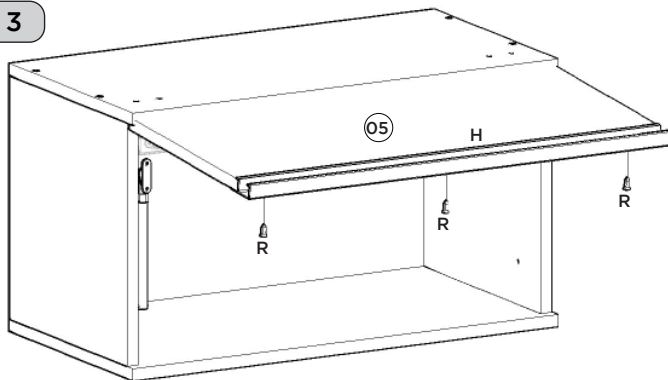

Video: Instalar e regular Dobradiças

Video: Instale y ajuste las bisagras

Video: Install and adjust hinges



Somente para (C77-139)

Solo para (C77-139)

Only for (C77-139)

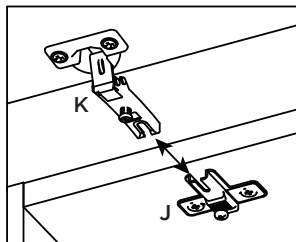
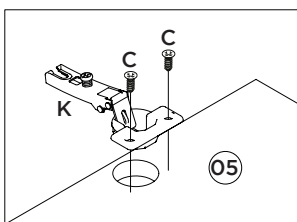
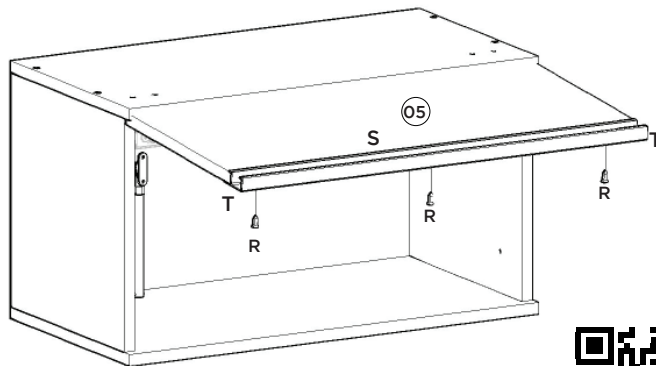
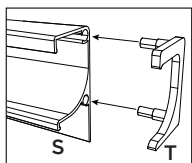

Video: Dicas para instalar o Kit Pistão à Gas

Video: Consejos para instalar el kit de pistón de gas



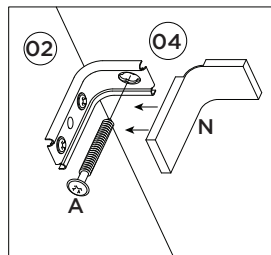
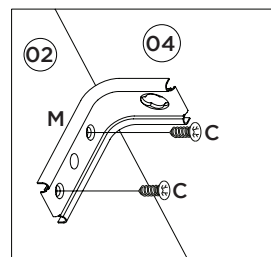
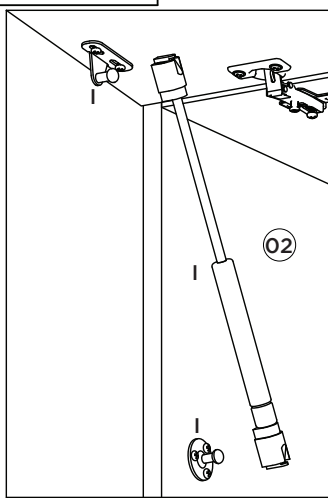
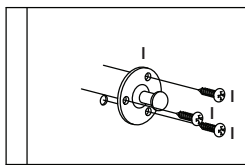
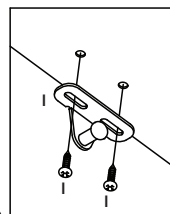
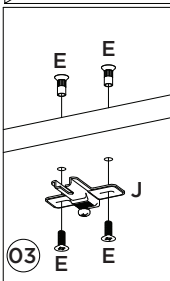









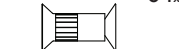

Video: Tips for installing the Gas Piston Kit

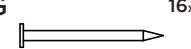

Lista de Peças | Lista de piezas | List of parts

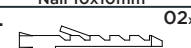
Item	Caixa Caja Box	Qtd Ctd Qty	Descrição Descripción Description	Medidas (mm) Dimensions (mm) Size (measurements) (mm)
01	1/1	01	Base Base Base	600x310x15
02	1/1	02	Lateral Direita Esquerda Lateral Derecha Izquierda Right Side Left	307x295x15
03	1/1	01	Tampo Tapa Top	600x310x15
04	1/1	01	Fundo Fondo Bottom	592x331x3
05	1/1	01	Porta Basculante Puerta Basculante Basculating Door	595x274x15
05	1/1	01	Porta Basculante Puerta Basculante Basculating Door (Somente para C77-139)	595x728x15

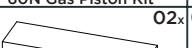
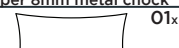
Ferragens | Herrajes | Hardware

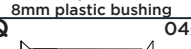
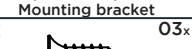
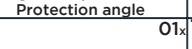
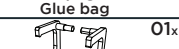
A  Parafuso 5,0x50mm FLA. Tornillo 5,0x50mm FLA. Screw 5,0x50mm FLA.	02x	B  Parafuso 3,5x40mm CHT. Tornillo 3,5x40mm CHT. Screw 3,5x40mm CHT.	08x	C  Parafuso 4,0x14mm CHT. Tornillo 4,0x14mm CHT. Screw 4,0x14mm CHT.	08x	D  Batente PVC para Porta Parada de PVC para Puerta PVC Door Stop	02x	E  Parafuso União 15mm Tornillo Unión 15mm Union Screw 15mm	04x
F  Cavilha 8x25mm Cinta 8x25mm Dowel 8x25mm	08x	G  Prego 10x10mm Clavo 10x10mm Nail 10x10mm	16x	H  Puxador Alum. MOV 595mm Tirador Alum. MOV 595mm Handle Alum. MOV 595mm	01x	I  Kit Pistão a Gás 60N Kit Pistón a Gas 60N 60N Gas Piston Kit	01x	J  Calço metal Super Alto 8mm Calzado metálico Super Alto 8mm Super 8mm metal chock	02x
K  Dobradiça metal 35mm Alta Bisagras metálicas 35mm Alta Metal hinge 35mm High	02x	L  Bucha plástica 8mm Bucha de plástico 8mm 8mm plastic bushing	02x	M  Suporte de fixação Soporte de fijación Mounting bracket	02x	N  Proteção para cantoneira Ángulo de protección Protection angle	02x	O  Sachê de cola Bolsa de pegamento Glue bag	01x
P  Adesivo tapa parafuso 10mm Adhesivo tapón de tornillo 10mm Bolt cover adhesive 10mm	08x	Q  Parafuso União 30mm Tornillo Unión 30mm Union Screw 30mm	04x	R  Parafuso 3,5x12mm CHT. Tornillo 3,5x12mm CHT. Screw 3,5x12mm CHT.	03x	S  Puxador MOV4083 - 591mm Tirador MOV4083 - 591mm MOV4083 - 591mm Handle	01x	T  Kit Ponteira Plastica MOV4083 Kit de punta de plástico MOV4083 Plastic Tip Kit MOV4083	01x

Somente para (C77-139)

Solo para (C77-139)

Only for (C77-139)



O parafuso (Q) deve ser usada somente quando este módulo for acoplado a outro módulo componível Henn.



El tornillo (Q) se debe utilizar sólo cuando el módulo está conectado a otro módulo componible Henn.



The screw (Q) should be used only when this module is attached to another Henn modular module.

RECOMENDAÇÃO

Para fixar o móvel na parede usar o suporte de fixação (M), o parafuso 4,0x14mm CHT (C), a Bucha 8mm (L) e o parafuso 5,0x50mm FLA (A).

RECOMENDACIÓN

Para conectar el móvil a la pared con el soporte (M), tornillo 4,0x14mm CHT (C), el casquillo de 8 mm (L) y el 5,0 x50mm tornillo FLA (A).

RECOMMENDATION

To fix the furniture to the wall use the fixing bracket (M), the 4.0x14mm CHT (C) screw, the 8mm bushing (L) and the 5.0x50mm FLA (A).

HENN

Ind. e Com. de Móveis Henn
Mondai - SC - Brasil

+55 49 3674.3500

@moveishenn
www.henn.com.br

INSTRUÇÕES DE MONTAGEM

INSTRUCCIONES DE MONTAJE
ASSEMBLY INSTRUCTIONS

Aéreo 01 Porta Basculante 800mm Connect | Aéreo 01 Puerta Basculante 800mm Connect | 01 air port Tipper 800mm Connect

- C54-35 - Duna/Cristal
- C54-42 - Fendi
- C54-139 - Off White

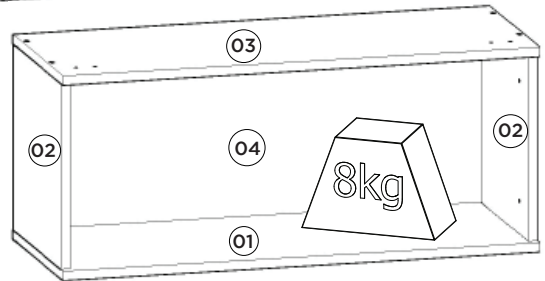
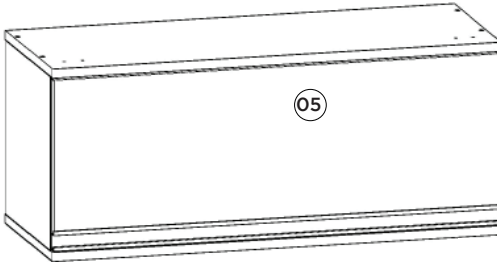

Pesos máximos recomendados
com carga distribuída
Peso máximo recomendado com
la carga distribuída
Recommended maximum weight
with distributed load.

Requisitos para montagem
Requisitos para la montaje
Assembly Requirements

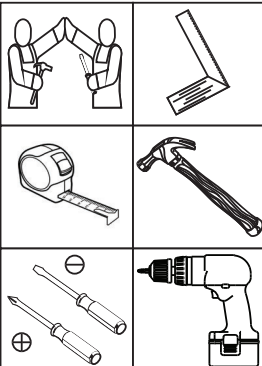

Imagens meramente ilustrativas
Imágenes meramente ilustrativas
Images for illustration only

AVISO

Para limpeza de seu móvel, use uma flanela seca ou úmedeca, e não utilize produtos químicos que possam danificar seu produto.

SISTEMA DE MONTAGEM

O sistema de montagem dos produtos, funciona de acordo com a ordem crescente dos números indicados no desenho. Ex: 01, 02, 03, 04... até a conclusão da montagem.

ASSISTÊNCIA TÉCNICA

Para solicitação de Assistência Técnica você consumidor deverá entrar em contato com o Lojista a qual você realizou a compra deste produto e solicitar a assistência técnica das peças avariadas. A garantia abrange todas as peças, partes e componentes que eventualmente venham apresentar defeito de fabricação no prazo de 03 (três) meses, contando a partir da entrega do produto ao consumidor, mediante nota fiscal de compra. Se houver qualquer alteração na estrutura do produto ou ocorrer defeito por negligência do montador/consumidor em relação a instrução de montagem e manuseio, não será fornecido assistência técnica gratuita.

ADVERTENCIA

Para limpieza de su móvil, use una flanela seca o húmeda, y no utilice productos químicos que puedan dañar su producto.

SISTEMA DE MONTAJE

El sistema de montaje de los productos funciona de acuerdo con el orden creciente de los números indicados en el dibujo. Ej.: 01, 02, 03, 04... hasta la conclusión del montaje.

ASISTENCIA TÉCNICA

Para solicitar Asistencia Técnica, el consumidor debe comunicarse con el Comercio que usted realizó la compra de este producto y solicita asistencia técnica para las partes dañadas. La garantía cubre todas las partes, piezas y componentes que eventualmente puedan presentar defecto de fabricación en el plazo de 03 (tres) meses, contados a partir de la entrega del producto al consumidor, mediante factura de compra. Si se produce algún cambio en la estructura del producto o se produce un defecto por negligencia del montador/consumidor en relación con las instrucciones de montaje y manipulación, no se prestará asistencia técnica gratuita.

NOTICE

To clean your furniture, use a dry or wet cloth, and do not use chemicals that may damage your product.

ASSEMBLY SYSTEM

The products' assembly system works according to the increasing order of the indicated numbers. For example: 01, 02, 03, 04 ... to the end of the assembly.

TECHNICAL ASSISTANCE

To request Technical Assistance, the consumer must contact the retailer from whom you purchased this product and request technical assistance for the damaged parts. The warranty covers all parts, parts and components that may eventually present a manufacturing defect within a period of 03 (three) months, counting from the delivery of the product to the consumer, by means of a purchase invoice. If there is any change in the structure of the product or defect occurs due to negligence of the assembler/consumer in relation to the assembly and handling instruction, free technical assistance will not be provided.

1º

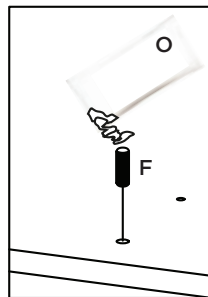
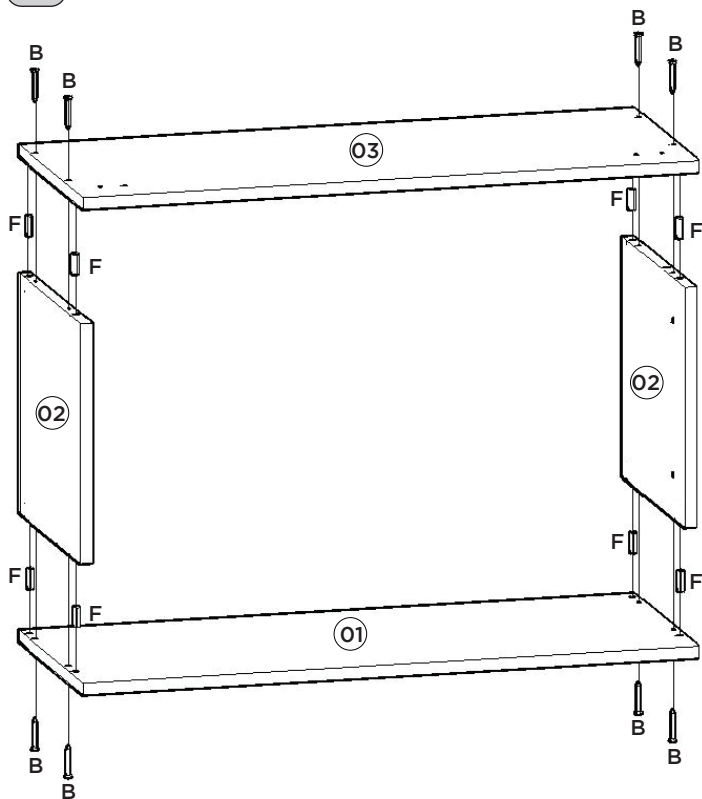

Utilizar o sachê de cola (O)
em todas as cavilhas (F)
do produto.

Con el pegamento sobre (O)
en todos los pernos (F)
producto.

Use the glue sachet (O) on all
the pegs (F) of the product.

2º

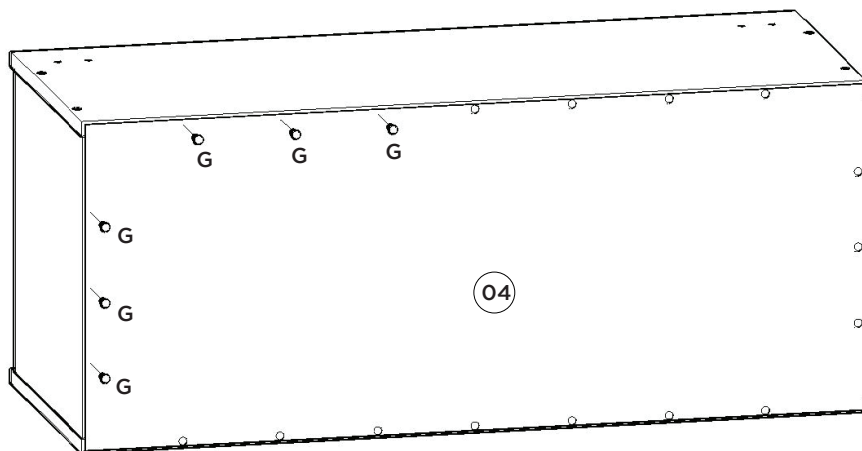

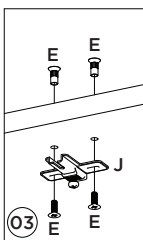
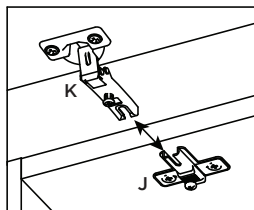
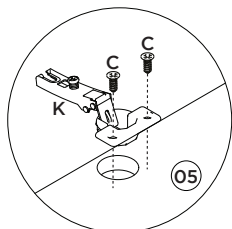
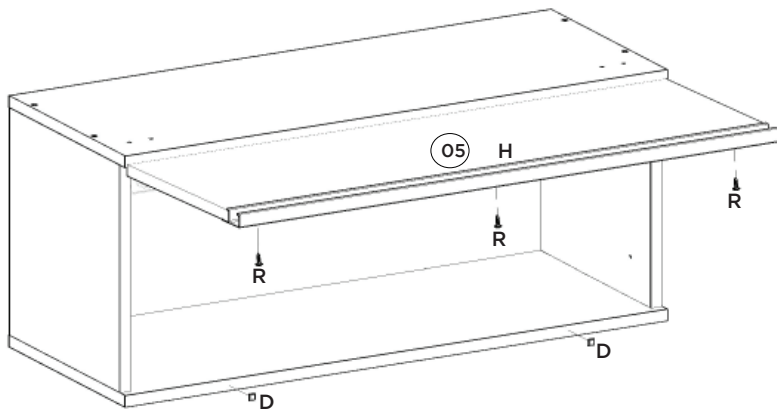
3^o

Video: Instalar e regular Dobradiças

Video: Instale y ajuste las bisagras

Video: Install and adjust hinges

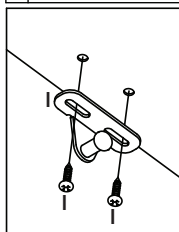
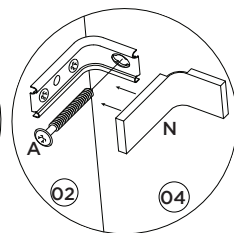
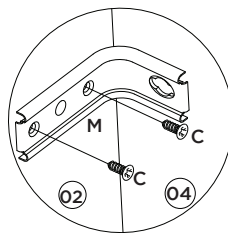
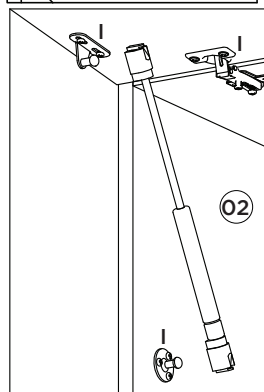
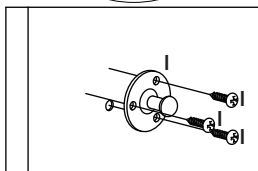

Video: Dicas para instalar o Kit Pistão à Gás

Video: Consejos para instalar el kit de pistón de gas

Video: Tips for installing the Gas Piston Kit

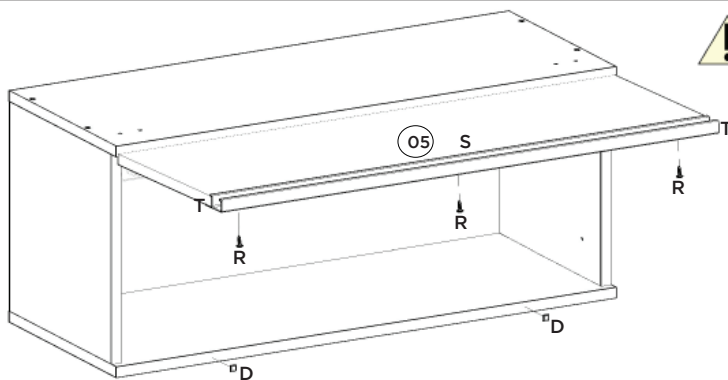

Somente para (C54-139)





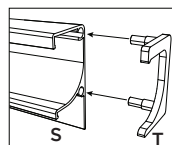







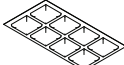

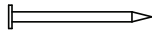

Solo para (C54-139)

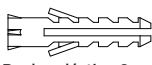
Only for (C54-139)

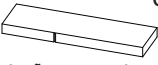

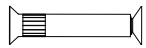

Item	Caixa Caja Box	Qtd Ctd Qty	Descrição Descripción Description	Medidas (mm) Dimensions (mm) Size (measurements) (mm)
01	1/1	01	Base Base Base	800x310x15
02	1/1	02	Lateral Direita Esquerda Lateral Derecha Izquierda Right Side Left	307x295x15
03	1/1	01	Tampo Tapa Top	800x310x15
04	1/1	01	Fundo Fondo Bottom	792x331x3
05	1/1	01	Porta Basculante Puerta Basculante Basculating Door	795x274x15
05	1/1	01	Porta Basculante Puerta Basculante Busculating Door (Somente para C54-139)	796x277x15

Ferragens | Herrajes | Hardware

A  Parafuso 5,0x50mm FLA. Tornillo 5,0x50mm FLA. Screw 5,0x50mm FLA.	02x	B  Parafuso 3,5x40mm CHT. Tornillo 3,5x40mm CHT. Screw 3,5x40mm CHT.	08x	C  Parafuso 4,0x14mm CHT. Tornillo 4,0x14mm CHT. Screw 4,0x14mm CHT.	08x	D  Batente PVC para Porta Parada de PVC para Puerta PVC Door Stop	02x	E  Parafuso União 15mm Tornillo Unión 15mm Union Screw 15mm	04x
F  Cavilha 8x25mm Cinta 8x25mm Dowel 8x25mm	08x	G  Prego 10x10mm Clavo 10x10mm Nail 10x10mm	20x	H  Puxador Alum. MOV 795mm Tirador Alum. MOV 795mm Handle Alum. MOV 795mm	01x	I  Kit Pistão a Gás 60N Kit Pistón a Gas 60N 60N Gas Piston Kit	01x	J  Calço metal Super Alto 8mm Calzado metálico Super Alto 8mm Super 8mm metal chock	02x
K  Dobradiça metal 35mm Alta Bisagras metálicas 35mm Alta Metal hinge 35mm High	02x	L  Bucha plástica 8mm Bucha de plástico 8mm 8mm plastic bushing	02x	M  Suporte de fixação Soporte de fijación Mounting bracket	02x	N  Proteção para cantoneira Ángulo de protección Protection angle	02x	O  Sachê de cola Bolsa de pegamento Glue bag	01x
P  Adesivo tapan de tornillo 10mm Bolt cover adhesive 10mm	08x	Q  Parafuso União 30mm Tornillo Unión 30mm Union Screw 30mm	04x	R  Parafuso 3,5x12mm CHT. Tornillo 3,5x12mm CHT. Screw 3,5x12mm CHT.	03x	S  Puxador MOV4083 - 792mm Tirador MOV4083 - 792mm MOV4083 - 792mm Handle	01x	T  Kit Ponteira Plastica MOV4083 Kit de punta de plástico MOV4083 Plastic Tip Kit MOV4083	01x

 O parafuso (Q) deve ser usada somente quando este módulo for acoplado a outro módulo componível Henn.

 El tornillo (Q) se debe utilizar sólo cuando el módulo está conectado a otro módulo componible Henn.

 The screw (Q) should be used only when this module is attached to another Henn modular module.

RECOMENDAÇÃO

Para fixar o móvel na parede usar o suporte de fixação (M), o parafuso 4,0x14mm CHT (C), a Bucha 8mm (L) e o parafuso 5,0x50mm FLA (A).

RECOMENDACIÓN

Para conectar el móvil a la pared con el soporte (M), tornillo 4,0x14mm CHT (C), el casquillo de 8 mm (L) y el 5,0 x50mm tornillo FLA (A).

RECOMMENDATION

To fix the furniture to the wall use the fixing bracket (M), the 4.0x14mm CHT (C) screw, the 8mm bushing (L) and the 5.0x50mm FLA screw (A).

HENN

Aéreo O3 Portas 1200mm Connect | Aéreo O3 Puertas 1200mm Connect |
Aerial O3 Doors 1200mm Connect

Referência/Cor
c C56-35 Duna/Cristal
c C56-42 Fendi
c C56-139 Off White

Requisitos para montagem
Requisitos para la montaje
Assembly Requirements

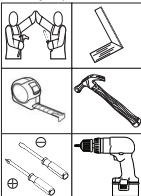

Imagens meramente ilustrativas, não acompanha o produto.
Imágenes ilustrativas, no incluidas con el producto.
Illustrative images, not included with the product.

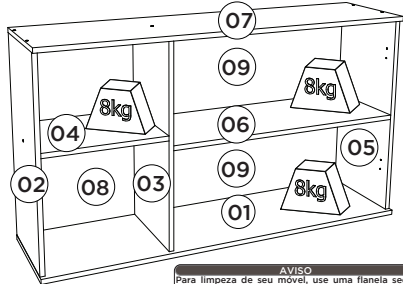
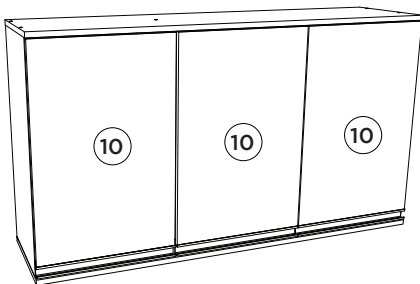

Pesos máximos recomendados com carga distribuída
Peso máximo recomendado con la carga distribuída
Recommended maximum weight with distributed load.

AVISO
Para limpeza de seu móvel, use uma flanela seca ou umedecida, e não utilize produtos químicos que possam danificar seu produto.

SISTEMA DE MONTAGEM
O sistema de montagem dos produtos, funciona de acordo com a ordem crescente dos números indicados no desenho. Ex: 01, 02, 03, 04... até a conclusão da montagem.

ASSISTÊNCIA TÉCNICA
Para solicitação de Assistência Técnica você consumidor deverá entrar em contato com o Lojista o qual você realizou a compra deste produto e solicitar a assistência técnica das peças avariadas. A garantia abrange todas as peças, partes e componentes que eventualmente venham apresentar defeito de fabricação no prazo de 03 (três) meses, contando a partir da entrega do produto ao consumidor, mediante nota fiscal de compra. Se houver qualquer alteração na estrutura do produto ou ocorrer defeito por negligência do montador/consumidor em relação a instrução de montagem e manipulação, não será fornecido assistência técnica gratuita.

ADVERTENCIA
Para limpieza de su mueble, use una flanela seca o húmeda, y no utilice productos químicos que puedan dañar su producto.

SISTEMA DE MONTAJE
El sistema de montaje de los productos funciona de acuerdo con el orden creciente de los números indicados en el dibujo. Ej: 01, 02, 03, 04... hasta la conclusión del montaje.

ASSISTENCIA TÉCNICA
Para solicitar Asistencia Técnica, el consumidor debe comunicarse con el Comercio que usted realizó la compra de este producto y solicita asistencia técnica para las partes dañadas. La garantía cubre todas las partes, piezas y componentes que eventualmente puedan presentar defecto de fabricación en el plazo de 03 (tres) meses, contados a partir de la entrega del producto al consumidor, mediante factura de compra. Si se produce algún cambio en la estructura del producto o se produce un defecto por negligencia del montador/consumidor en relación con las instrucciones de montaje y manipulación, no se prestará asistencia técnica gratuita.

NOTICE
To clean your furniture, use a dry or wet cloth, and do not use chemicals that may damage your product.

Lista de Peças | Lista de piezas | List of parts

Item	Caixa Caja Box	Qty	Descrição Descripción Description	Medidas (mm) Dimensions (mm) Size (measurements) (mm)
01	1/1	01	Base Base Base	1200x310x15
02	1/1	01	Lateral Esquerda Lateral Izquierda Right Left	645x295x15
03	1/1	01	Divisão División Division	645x295x15
04	1/1	01	Prateleira Menor Estante Pequeno Smaller Shelf	381x295x15
05	1/1	01	Lateral Direita Lateral Derecha Right Side	645x295x15
06	1/1	01	Prateleira Estante Shelf	772x295x15
07	1/1	01	Tampo Tapa Top	1200x310x15
08	1/1	01	Fundo Lateral Fondo Lateral Lateral Background	669x400x3
09	1/1	02	Fundo Fondo Bottom	791x334x3
10	1/1	03	Porta Puerta Door	612x396x15
10	1/1	03	Porta Puerta Door (Somente para C56-139)	616x396x15

Ferragens | Herrajes | Hardware

A 03	B 14	C 42	D 51	E 20	F 06
Parafuso 5,0x50mm FLA. Tornillo 5,0x50mm FLA. Screw 5,0x50mm FLA.	Parafuso 3,5x40mm CHT. Tornillo 3,5x40mm CHT. Screw 3,5x40mm CHT.	Parafuso 4,0x14mm CHT. Tornillo 4,0x14mm CHT. Screw 4,0x14mm CHT.	Prego 10x10mm Clavo 10x10mm Nail 10x10mm	Cavilha 8x25mm Cinta 8x25mm Dowel 8x25mm	Chave Allen 30mm POP Cavilha 8x25mm Cinta 8x25mm Dowel 8x25mm
G 01	H 06	I 03	J 03	K 03	L 04
Kit Ponteira Plástica MOV4083 Kit de punta de plástico MOV4083 Plastic Tip kit MOV4083	Parafuso 3,5x12mm CHT. Tornillo 3,5x12mm CHT. Screw 3,5x12mm CHT.	Bucha plástica 8mm Buchas de plástico 8mm 8mm plastic bushing	Suporte de fixação Soporte de fijación Mounting bracket	Proteção para cantoneira Angulo de protección Protection angle	Parafuso União 30mm Tornillo Unión 30mm Union Screw 30mm
M 04	N 02	O 12	P 13	Q 03	R 01
Batente PVC para Porta Parada de PVC para Puerta PVC Door Stop	Sachê de cola Bolsa de pegamento Glue bag	Adesivo tapa parafuso 10mm Adhesivo tapón de tornillo 10mm Bolt cover adhesive 10mm	Fixador de fundos Fijador de fondos Bottom fixer	Giz de correção Tiza de corrección Chalk of correction	Etiqueta resinada Henn Etiqueta resinada Henn Henn resin label

ASSEMBLY SYSTEM
The products' assembly system works according to the increasing order of the indicated numbers. For example: 01, 02, 03, 04 ... to the end of the assembly.

TECHNICAL ASSISTANCE
To request Technical Assistance, the consumer must contact the retailer from whom you purchased this product and request technical assistance for the damaged parts. The warranty covers all parts, parts and components that may eventually present a manufacturing defect within a period of 03 (three) months, counting from the delivery of the product to the consumer, by means of a purchase invoice. If there is any change in the structure of the product or defect occurs due to negligence of the assembler/consumer in relation to the assembly and handling instruction, free technical assistance will not be provided.

O parafuso (L) deve ser usada somente quando este módulo for acoplado a outro módulo componível Henn.

El tornillo (L) se debe utilizar sólo cuando el módulo está conectado a otro módulo componible Henn.

The screw (L) should be used only when this module is attached to another Henn modular module.

RECOMENDAÇÃO
Para fixar o móvel na parede usar o suporte de fixação (J), o parafuso 4,0x14mm CHT (C), a Bucha 8mm (I) e o parafuso 5,0x50mm FLA (A).

RECOMENDACIÓN
Para conectar el móvil a la pared con el soporte (J), tornillo 4,0x14mm CHT (C), el casquillo de 8 mm (I) y el 5,0x50mm tornillo FLA (A).

RECOMENDACION
To fix the furniture to the wall use the fixing bracket (J), the 4,0x14mm CHT (C) screw, the 8mm bushing (I) and the 5.0x50mm FLA screw (A).

1

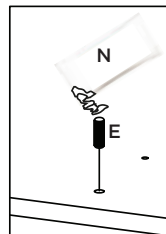
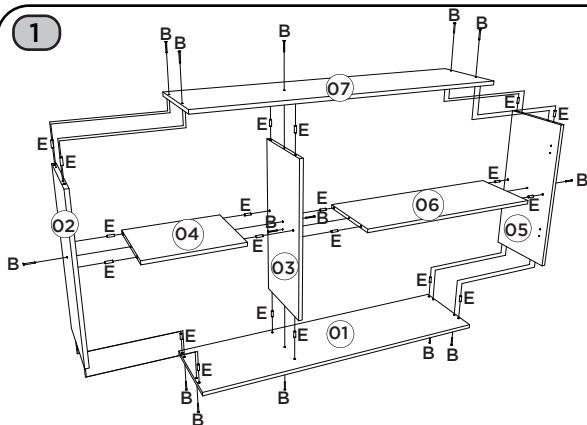

Utilizar o sachê de cola (N) em todas as cavilhas (E) do produto.

Con el pegamento sobre (N) en todos los pernos (E) producto.

Use the glue sachet (N) on all the pegs (E) of the product.

2

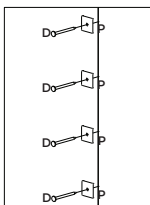
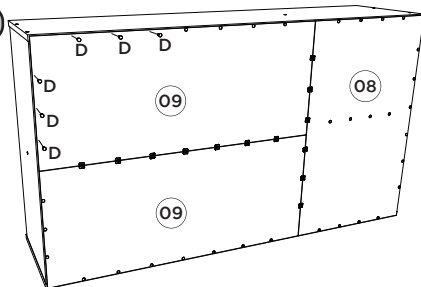

Para saber mais sobre como fixar o móvel de maneira correta, acesse:

Para obtener más información sobre cómo arreglar los muebles correctamente, visite:

To learn more about how to fix the furniture correctly, visit:



<http://bit.ly/guia-de-fixacao-henn>

3



Imprescindível a fixação do produto na parede.

Es imprescindible la fijación del producto en la pared.

Indispensable to fix the product on the wall.

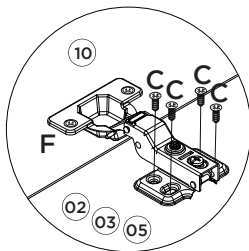
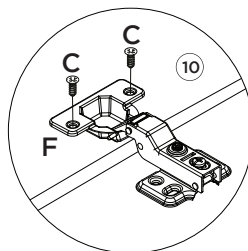
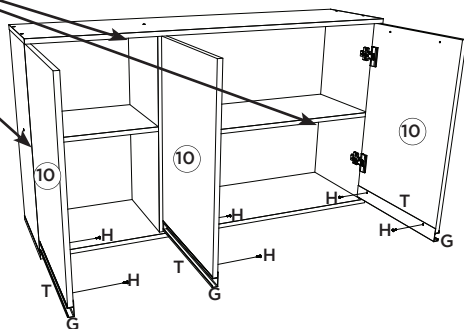
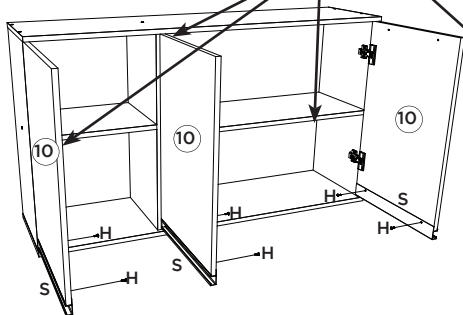
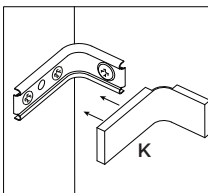
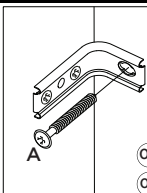
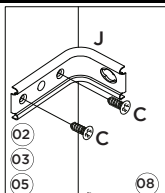

Somente para (C56-139)

Solo para (C56-139)

Only for (C56-139)

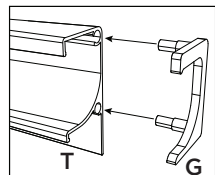

2

Balcão Pia 02 Gavetas 03 Portas Connect

Pia Contador 02 Cajones 03 Puertas Connect | Balcony Pia 02 Drawers 03 Doors Connect

C66-35 Duna/Cristal | C66-42 Fendi

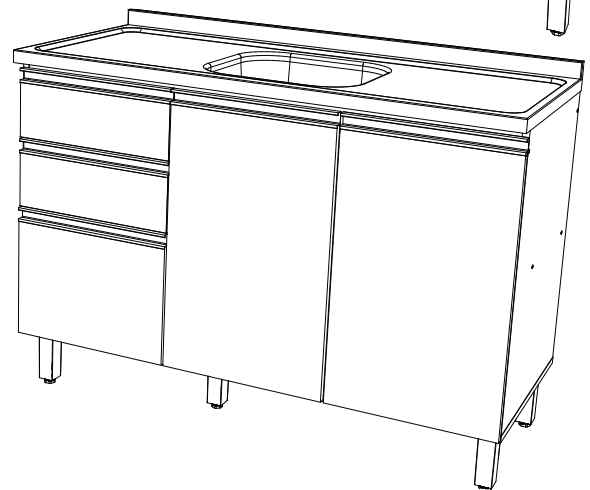
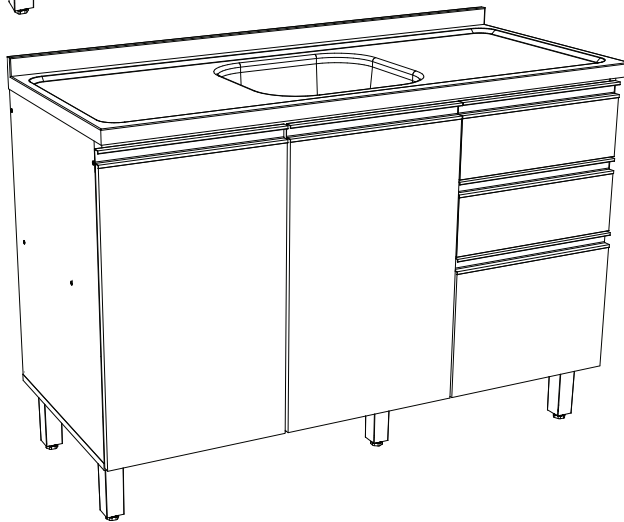
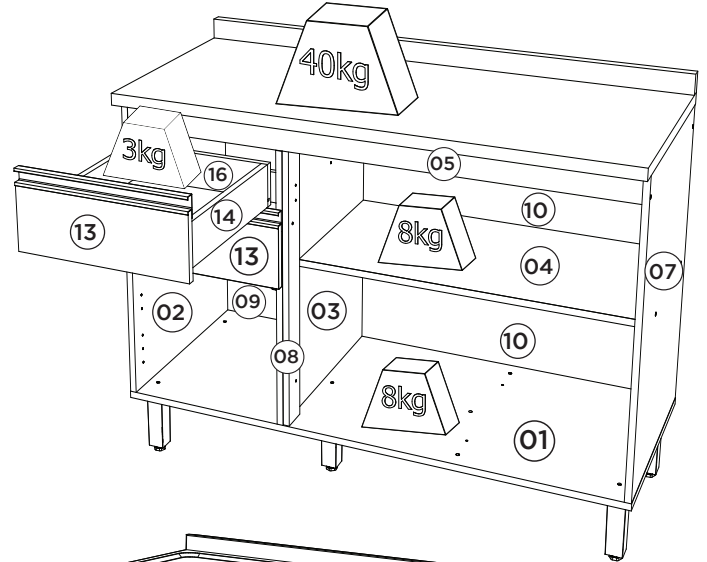
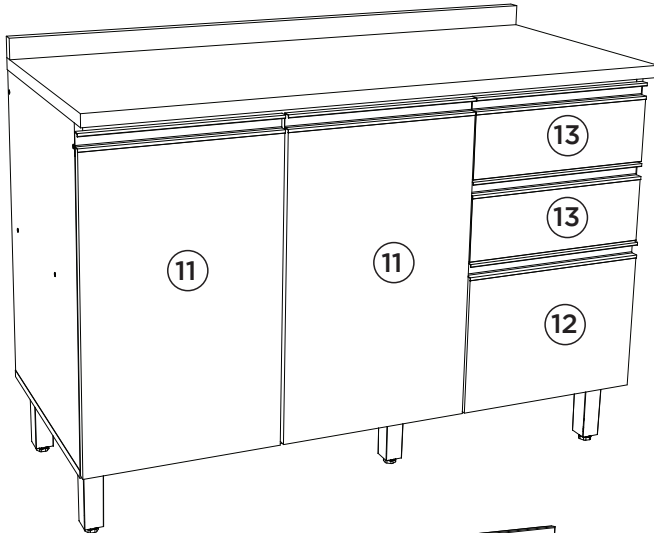

Pesos máximos recomendados com carga distribuída
Peso máximo recomendado con la carga distribuida
Recommended maximum weights with evenly distributed.

Requisitos para montagem Requisitos para la montaje Assembly Requirements

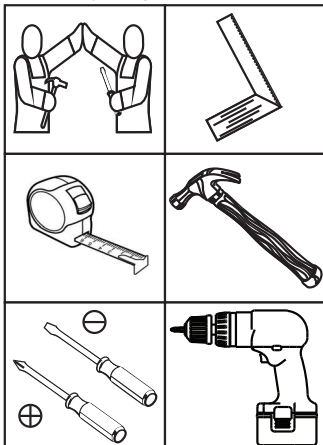

Imagens meramente ilustrativas, não acompanha o produto.
Imágenes ilustrativas, no incluidas con el producto.
Illustrative images, not included with the product.

AVISO

Para limpeza de seu móvel, use uma flanela seca ou umedecida, e não utilize produtos químicos que possam danificar seu produto.

SISTEMA DE MONTAGEM

O sistema de montagem dos produtos, funciona de acordo com a ordem crescente dos números indicados no desenho. Ex: 01, 02, 03, 04... até a conclusão da montagem.

ASSISTÊNCIA TÉCNICA

Para solicitação de Assistência Técnica você consumidor deverá entrar em contato com o Lojista o qual você realizou a compra deste produto e solicitar a assistência técnica das peças avariadas. A garantia abrange todas as peças, partes e componentes que eventualmente venham apresentar defeito de fabricação no prazo de 03 (três) meses, contando a partir da entrega do produto ao consumidor, mediante nota fiscal de compra. Se houver qualquer alteração na estrutura do produto ou ocorrer defeito por negligência do montador/consumidor em relação a instrução de montagem e manuseio, não será fornecido assistência técnica gratuita.

ADVERTENCIA

Para limpieza de su móvil, use una flanela seca o húmeda, y no utilice productos químicos que puedan dañar su producto.

SISTEMA DE MONTAJE

El sistema de montaje de los productos funciona de acuerdo con el orden creciente de los números indicados en el dibujo. Ej.: 01, 02, 03, 04... hasta la conclusión del montaje.

ASISTENCIA TÉCNICA

Para solicitar Asistencia Técnica, el consumidor debe comunicarse con el Comercio que usted realizó la compra de este producto y solicita asistencia técnica para las partes dañadas. La garantía cubre todas las partes, piezas y componentes que eventualmente puedan presentar defecto de fabricación en el plazo de 03 (tres) meses, contados a partir de la entrega del producto al consumidor, mediante factura de compra. Si se produce algún cambio en la estructura del producto o se produce un defecto por negligencia del montador/consumidor en relación con las instrucciones de montaje y manipulación, no se prestará asistencia técnica gratuita.

NOTICE

To clean your furniture, use a dry or wet cloth, and do not use chemicals that may damage your product.

ASSEMBLY SYSTEM

The products' assembly system works according to the increasing order of the indicated numbers. For example: 01, 02, 03, 04 ... to the end of the assembly.

TECHNICAL ASSISTANCE

To request Technical Assistance, the consumer must contact the retailer from whom you purchased this product and request technical assistance for the damaged parts. The warranty covers all parts, parts and components that may eventually present a manufacturing defect within a period of 03 (three) months, counting from the delivery of the product to the consumer, by means of a purchase invoice. If there is any change in the structure of the product or defect occurs due to negligence of the assembler/consumer in relation to the assembly and handling instruction, free technical assistance will not be provided.

1º

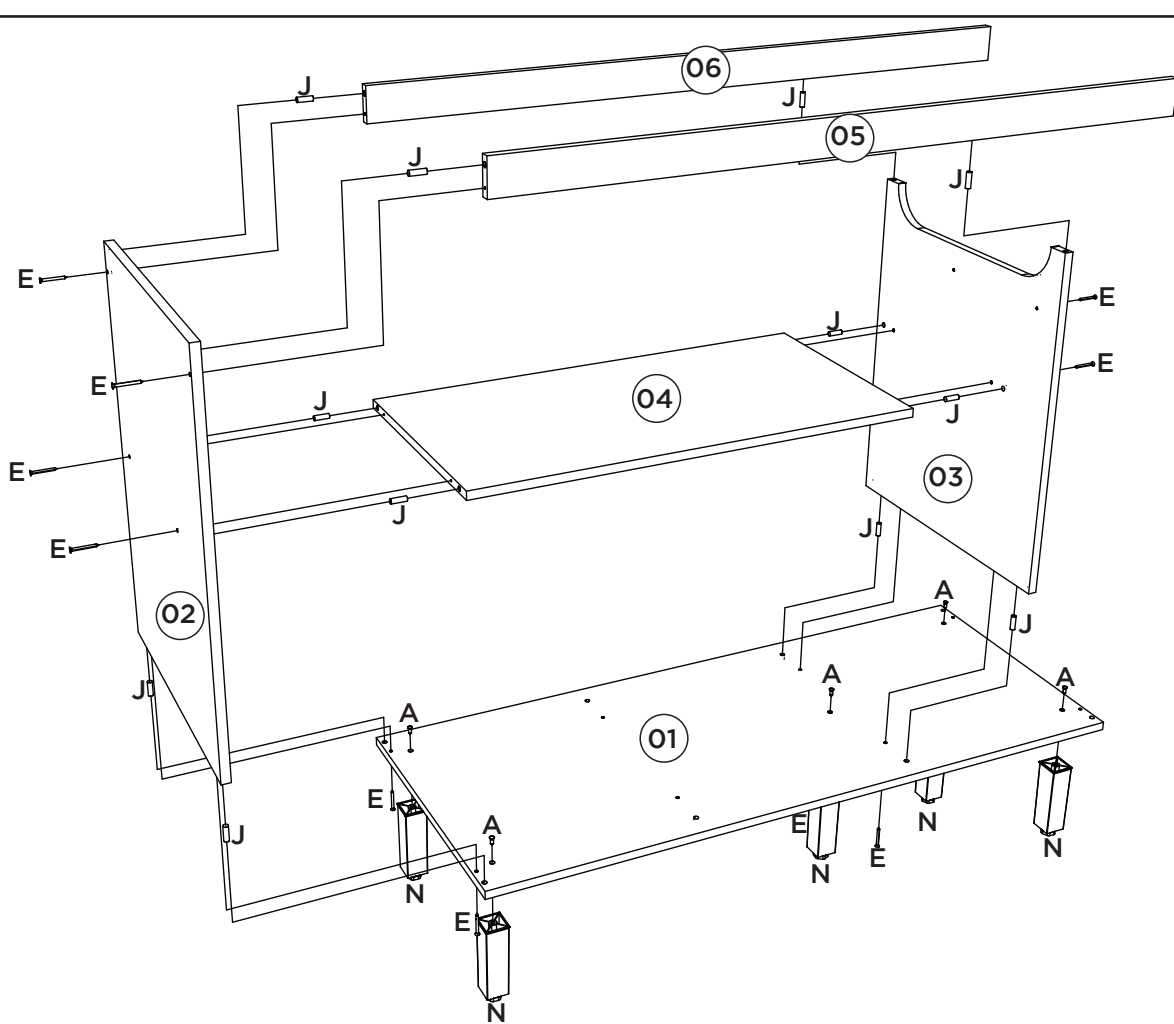

2º

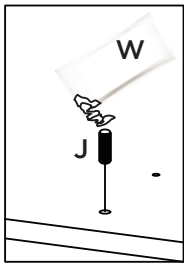

Utilizar o sachê de cola (W) em todas as cavilhas (J) do produto.

Con el pegamento sobre (W) en todos los pernos (J) producto.

Use the glue sachet (W) on all the pegs (J) of the product.

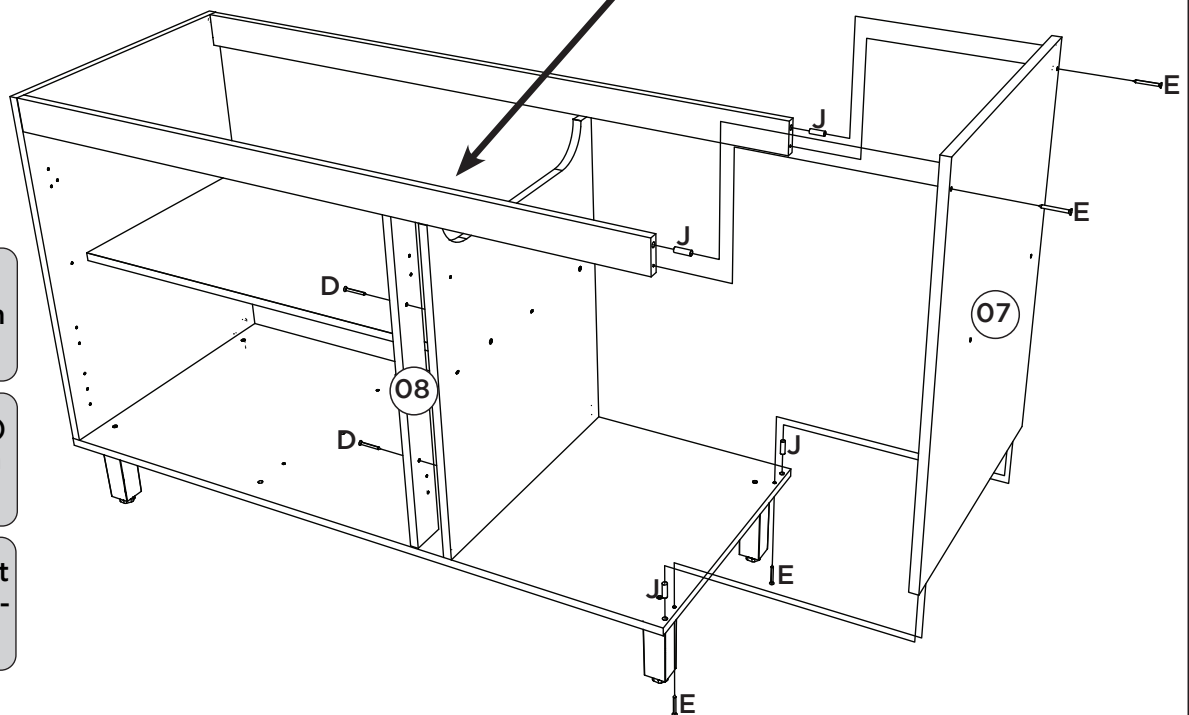
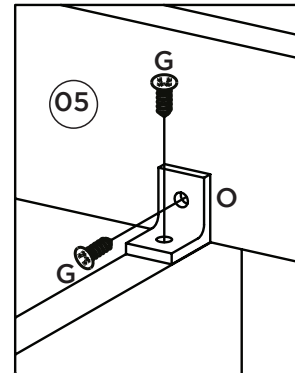

A pilastra da porta (08) deve estar alinhada com a divisão (03).

El pilar de la puerta (08) debe estar alineada con la división (03).

The door pillar (08) must be aligned with the partition (03).

3º

Esse tampo é opcional e é vendido separadamente (C905-33).

Esta vez es opcional y se vende por separado (C905-33).

This top is optional and is sold separately (C905-33).

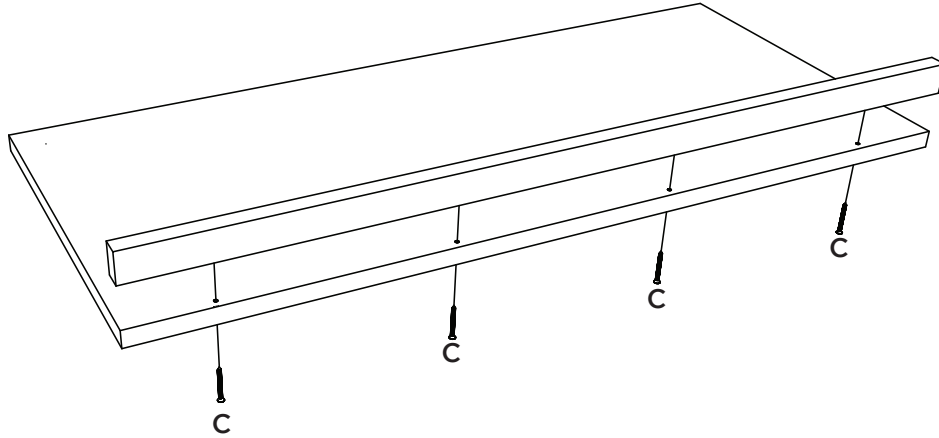

4º

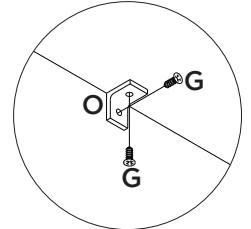

Caso o móvel seja montado com a opção do tampo, fixar o mesmo com 06 cantoneiras (O) e os parafusos 3,5x14mm (G).

Si se monta el auricular con la opción de la cubierta, fijarlo con Los ángulos 06 (O) y 3,5 x14mm tornillos (G).

If the furniture is to be installed with the top cover option, fix it with 06 (O) and 3.5x14mm screws (G).

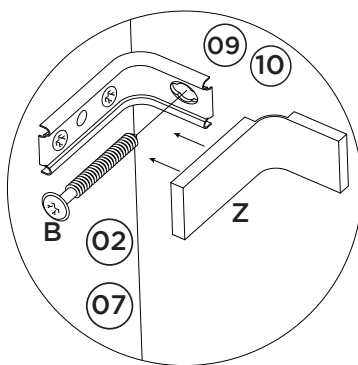
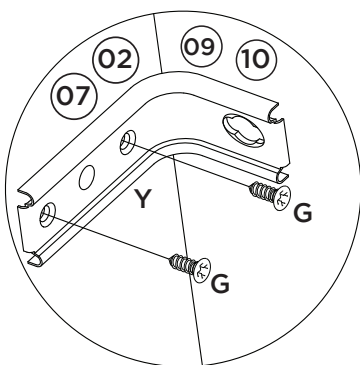
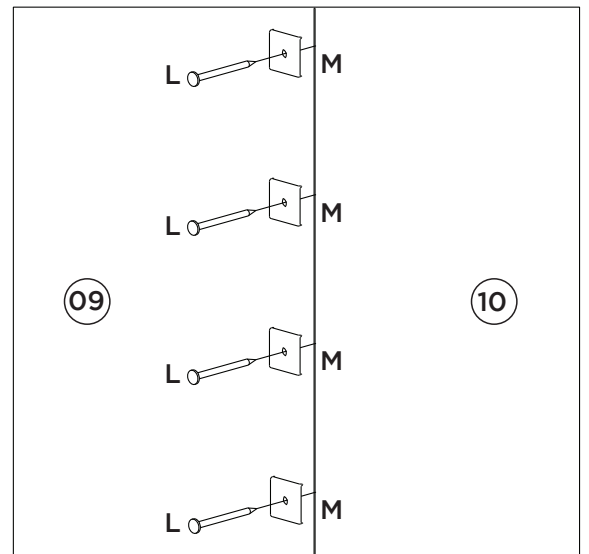
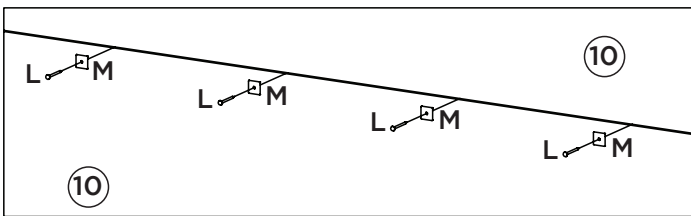
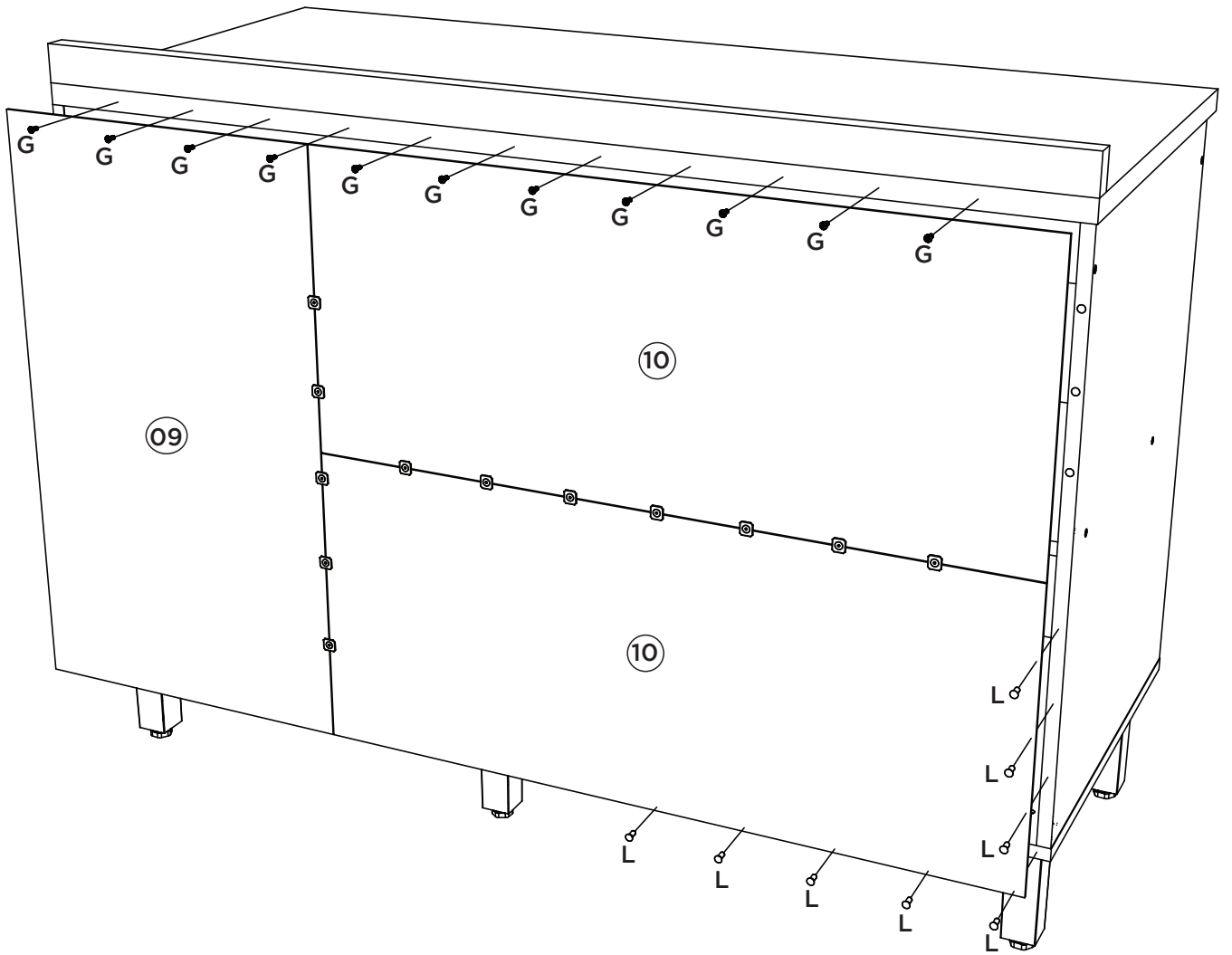

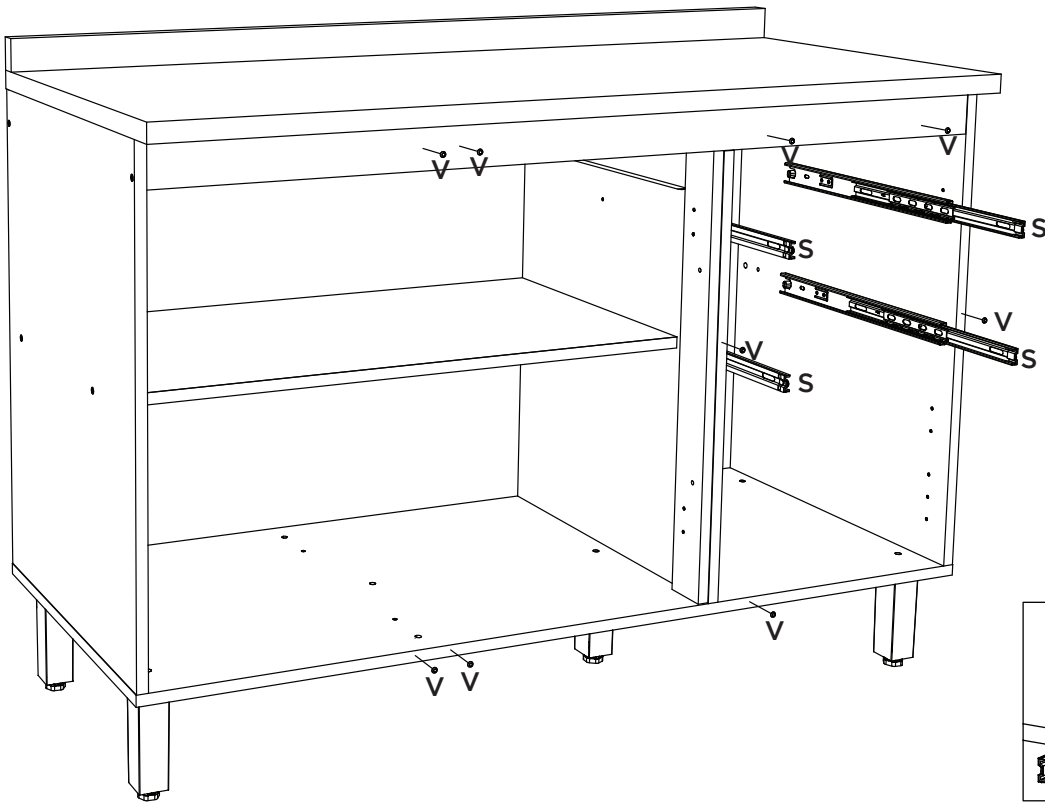

Vídeo: Dicas para fixar a Corrediça

Video: Consejos para arreglar la diapositiva

Video: Tips for Fixing the Slide

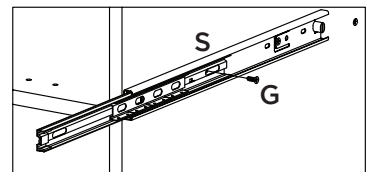
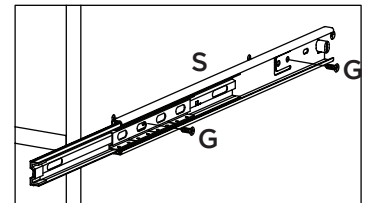

Fixação da corrediça telescópica (S).

Fijación Slide telescópico (S).

Fixing of the telescopic slide (S).

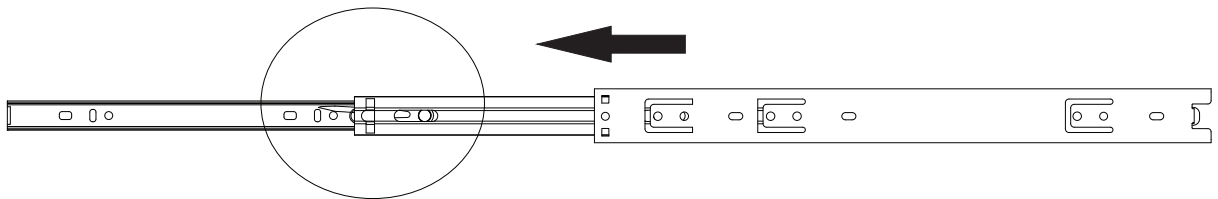

Para a desmontagem da corrediça siga a instrução ao lado.

Para el desmontaje seguimiento de diapositivas la instrucción siguiente a.

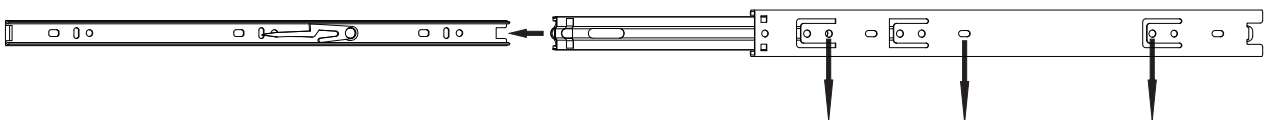
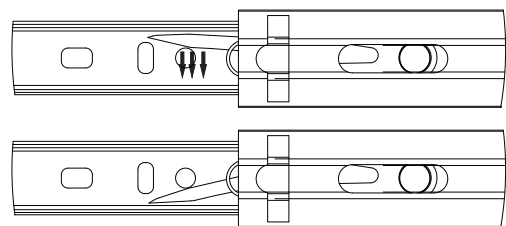

Fixar as corrediças nessas furações

Fijar las diapositivas de estos agujeros

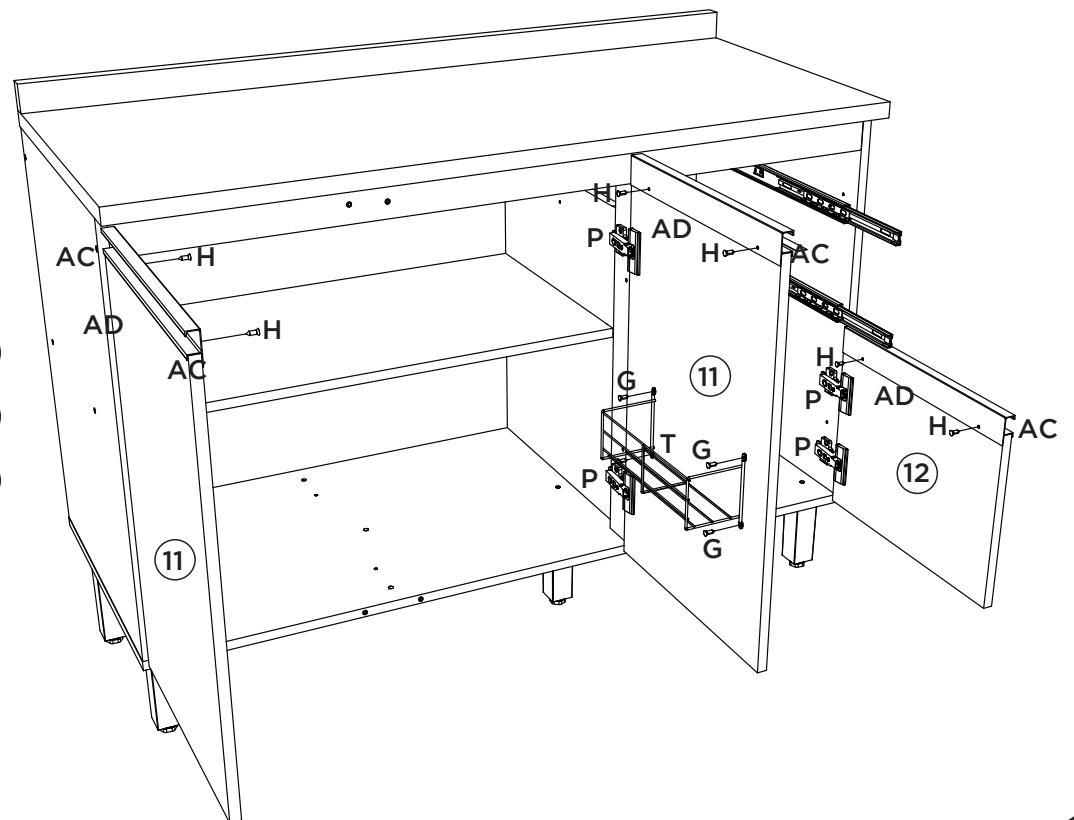
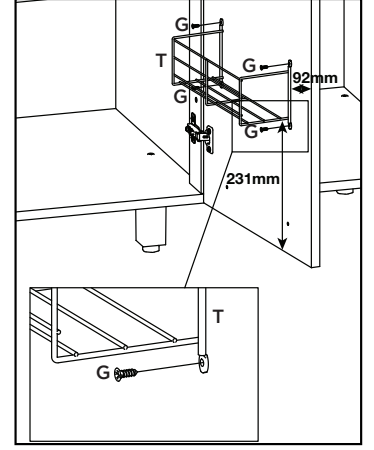
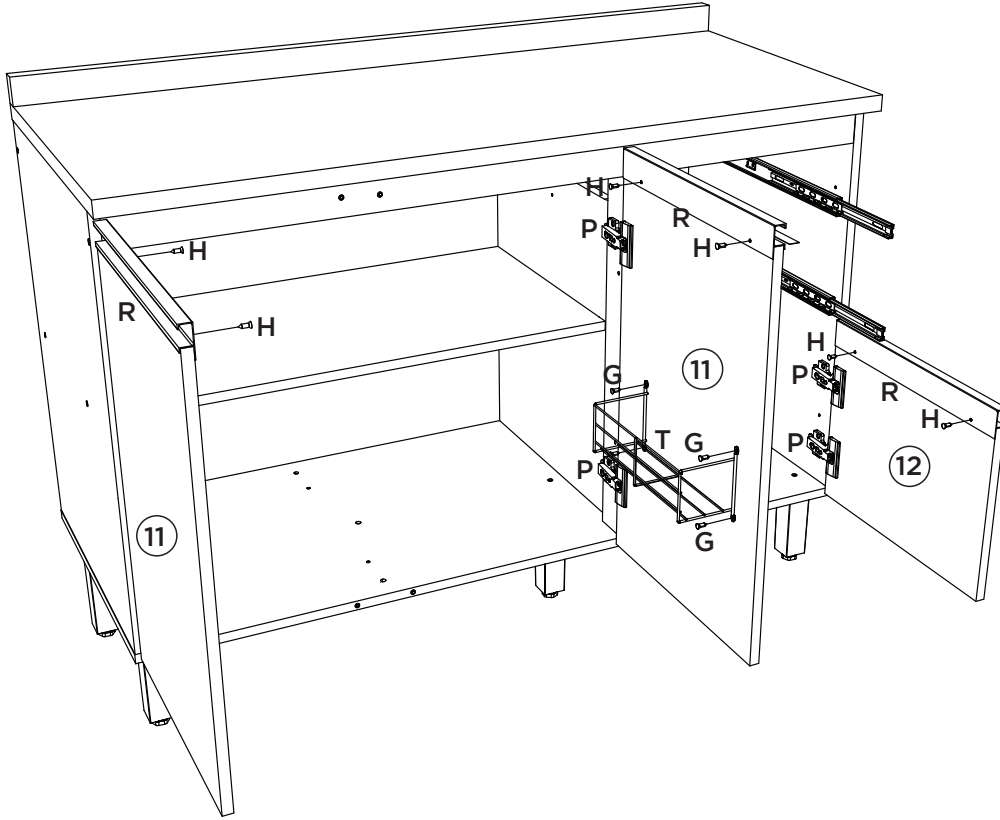
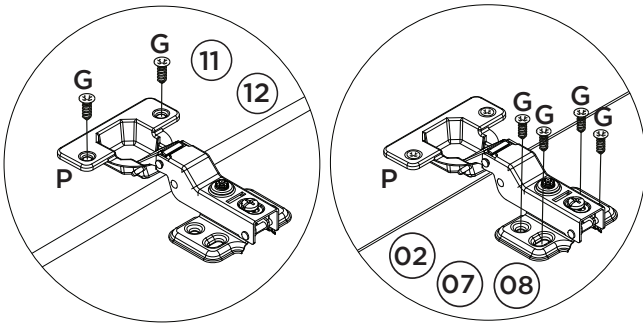

- Somente para (C66-139)
- Solo para (C66-139)
- Only for (C66-139)

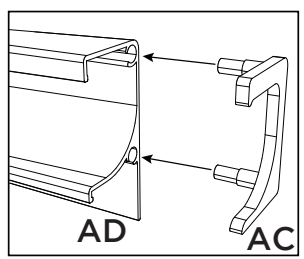

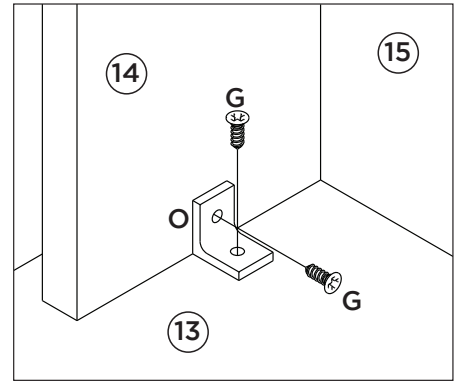
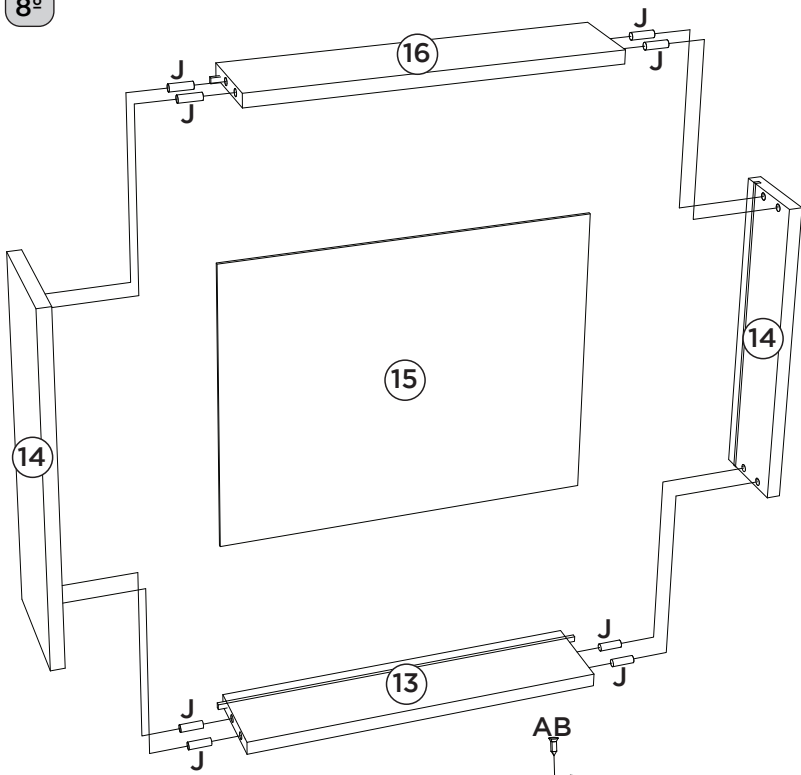

Somente para (C66-139)

Solo para (C66-139)

Only for (C66-139)

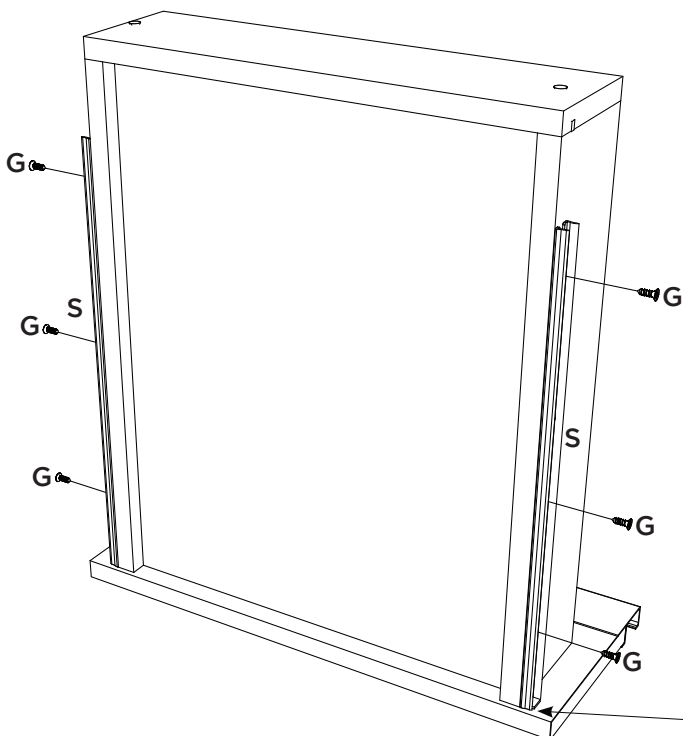
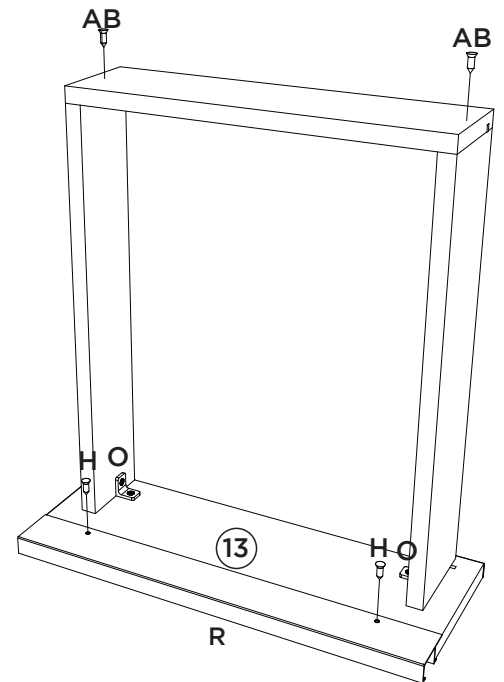
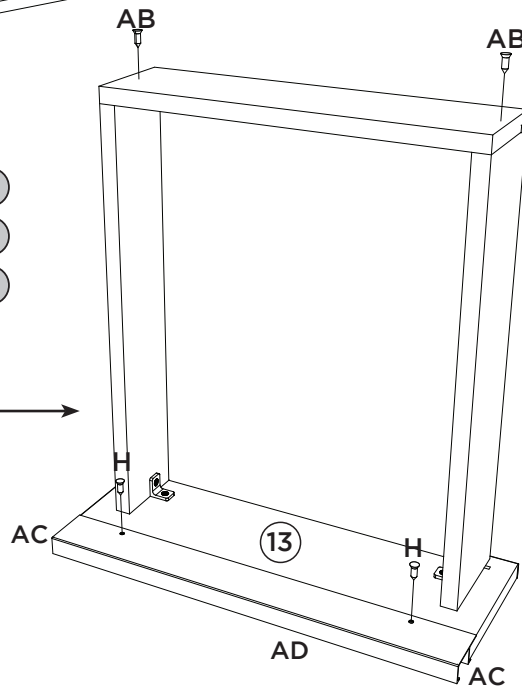
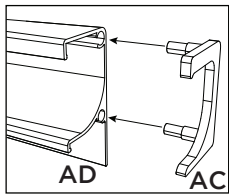











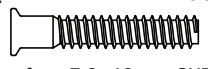
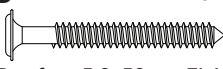



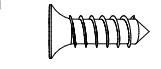



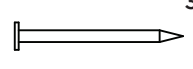
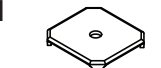
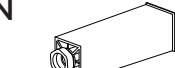

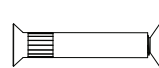

Deixar 3mm de distância da frente de gaveta.

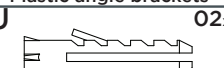
Deje una separación de 3mm del frente del cajón.

Leave 3mm away from the front of the drawer.

Item	Caixa Caja Box	Qty Ctd Qty	Descrição Descripción Description	Medidas (mm) Dimensions (mm) Size (measurements) (mm)
01	1/1	01	Base Base Base	1200x490x15
02	1/1	01	Lateral esquerda Lateral izquierda Left side	660x490x15
03	1/1	01	Divisão División Division	600x490x15
04	1/1	01	Prateleira Estante Shelf	783x400x15
05	1/1	01	Travessa frontal Travesaño frontal Front crossbar	1168x60x15
06	1/1	01	Travessa traseira Travesaño trasero Rear bumper	1168x60x15
07	1/1	01	Lateral direita Lateral derecha Right side	660x490x15
08	1/1	01	Pilastra da Porta Pilastra Puerta Pilaster door	599x60x15
09	1/1	01	Fundo menor Fondo menor Minor fund	683x389x3
10	1/1	02	Fundo Fondo Bottom	802x341x3
11	1/1	02	Porta Puerta Door	625x396x15
11	1/1	02	Porta Puerta Door (Somente para C66-139)	629x396x15
12	1/1	01	Porta menor Puerta menor Smaller door	396x290x15
12	1/1	01	Porta menor Puerta menor Smaller door (Somnete para C66-139)	396x294x15
13	1/1	02	Frente de gaveta Frente de cajón Front of drawer	396x136x15
13	1/1	02	Frente de gaveta Frente de cajón Front of drawe (Somnete pra C66-139)	396x140x15
14	1/1	04	Lado de Gaveta menor Lado del cajón menor Smallest Drawer Side	400x90x15
15	1/1	02	Fundo de gaveta Fondo de cajón Bottom of drawer	411x326x3
16	1/1	02	Ripa de trás Malla detrás Rear lath	345x90x15

Ferragens | Herrajes | Hardware

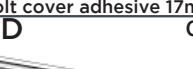
A  Parafuso 7,0x40mm CHT. Tornillo 7,0x40mm CHT. Screw 7,0x40mm CHT.	B  Parafuso 5,0x50mm FLA. Tornillo 5,0x50mm FLA. Screw 5,0x50mm FLA.	C  Parafuso 4,5x50mm CHT. Tornillo 4,5x50mm CHT. Screw 4,5x50mm CHT.	D  Parafuso 4,0x25mm CHT. Tornillo 4,0x25mm CHT. Screw 4,0x25mm CHT.	E  Parafuso 3,5x40mm CHT. Tornillo 3,5x40mm CHT. Screw 3,5x40mm CHT.	F  Divisor talheres 398x313mm Divisor cubiertos 398x313mm Cutlery divider 398x313mm
G  Parafuso 4,0x14mm CHT. Tornillo 4,0x14mm CHT. Screw 4,0x14mm CHT.	H  Parafuso 3,5x12mm CHT. Tornillo 3,5x12mm CHT. Screw 3,5x12mm CHT.	I  Giz de correção Tiza de corrección Chalk of correction	J  Cavilha 8x25mm Cinta 8x25mm Dowel 8x25mm	K  Etiqueta resinada Henn Etiqueta resinada Henn Henn resin label	L  Prego 10x10mm Clavo 10x10mm Nail 10x10mm
M  Fixador de fundos Fijador de fondos Bottom fixer	N  Pé 145mm x 42mm Pie 145mm x 42mm Foot 145mm x 42mm	O  Cantoneira plástica Cantонера plástica Plastic angle brackets	P  Dobradilha 35mm POP Baixa c Amort + Calço Fixo Bisagra baja POP de 35 mm con amortiguación + cuña fija 35mm POP Low Hinge with Damping + Fixed Shim	Q  Parafuso União 30mm Tornillo Unión 30mm Union Screw 30mm	R  Puxador MOV 396mm Tirador MOV 396mm MOV 396mm Handle
S  Corrediza telescópica Diapositivas telescópicas Telescopic slides	T  Porta detergente 256x91mm Puerta detergente 256x91mm Detergent door 256x91mm	U  Bucha plástica 8mm Bucha de plástico 8mm 8mm plastic bushing	V  Batente PVC para Porta Parada de PVC para Puerta PVC Door Stop	W  Sachê de cola Bolsa de pegamento Glue bag	X  Adesivo tapa parafuso 17mm Adhesivo tapón de tornillo 17mm Bolt cover adhesive 17mm
Y  Suporte de fixação Soporte de fijación Mounting bracket	Z  Proteção para cantoneira Ángulo de protección Protection angle	AA  Adesivo tapa parafuso 10mm Adhesivo tapón de tornillo 10mm Bolt cover adhesive 10mm	AB  Parafuso 3,0x30mm CHT. Tornillo 3,0x30mm CHT. Screw 3,0x30mm CHT.	AC  Kit Ponteira Plastica MOV4083 Kit de punta de plástico MOV4083 Plastic Tip Kit MOV4083	AD  Puxador MOV4083 - 392mm Tirador MOV4083 - 392mm MOV4083 - 392mm Handle

Somente para (C66-139)

Solo para (C66-139)

Only for (C66-139)



O parafuso (Q) deve ser usada somente quando este módulo for acoplado a outro módulo componível Henn.

RECOMENDAÇÃO

Para fixar o móvel na parede usar o suporte de fixação (Y), o parafuso 4,0x14mm CHT (G), a Bucha 8mm (U) e o parafuso 5,0x50mm FLA (B).



El tornillo (Q) se debe utilizar sólo cuando el módulo está conectado a otro módulo componible Henn.

RECOMENDACIÓN

Para conectar el móvil a la pared con el soporte (Y), tornillo 4,0 x14mm CHT (G), el casquillo de 8 mm (U) y el 5,0 x50mm tornillo FLA (B).



The screw (Q) should be used only when this module is attached to another Henn modular module.

RECOMMENDATION

To fix the furniture to the wall use the mounting bracket (Y), the 4.0x14mm CHT (G) screw, the 8mm bushing (U) and the 5.0x50mm FLA (B).

HENNInd. e Com. de Móveis Henn
Mondai - SC - Brasil

☎+55 49 3674.3500

📧@moveishenn
www.henn.com.br**INSTRUÇÕES DE MONTAGEM****INSTRUCCIONES DE MONTAJE
ASSEMBLY INSTRUCTIONS****Balcão 03 Gavetas 600mm Connect | Contador 03 Cajones 600mm Connect | Counter 03 Drawers 600mm Connect**

- C63-35 - Duna/Cristal
- C63-42 - Fendi
- C63-139 - Off White

Requisitos para montagem
Requisitor para la montaje
Assembly Requirements

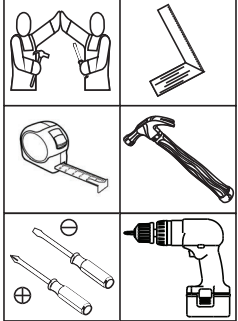

Imagens meramente ilustrativas
Imágenes meramente ilustrativas
Images for illustration only

Pesos máximos recomendados com carga distribuída
Peso máximo recomendado con la carga distribuída
Recommended maximum weights with evenly distributed.

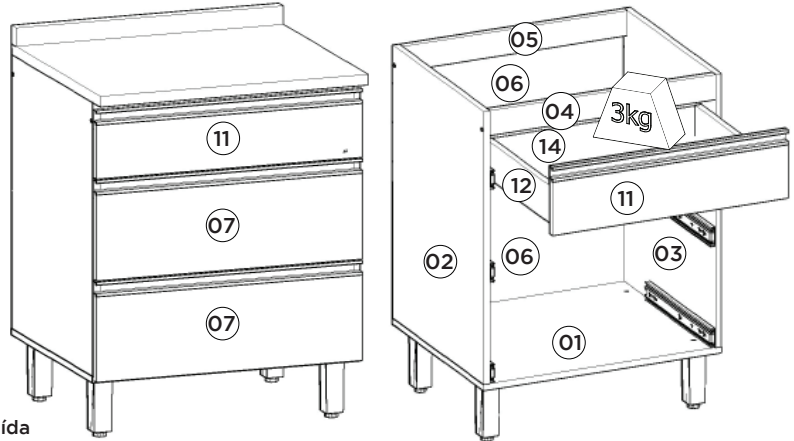
**Lista de Peças | Lista de piezas | List of parts**

Item	Caixa Caja Box	Qty Ctd Qty	Descrição Descripción Description	Medidas (mm) Dimensions (mm) Size (measurements) (mm)
01	1/1	01	Base Base Base	600x490x15
02	1/1	01	Lateral esquerda Lateral izquierda Left side	660x490x15
03	1/1	01	Lateral direita Lateral derecha Right side	660x490x15
04	1/1	01	Travessa frontal Travesaño frontal Front crossbar	568x60x15
05	1/1	01	Travessa traseira Travesaño trasero Rear bumper	568x60x15
06	1/1	02	Fundo Fondo Bottom	592x310x3
07	1/1	02	Frente de gaveta Frente de cajón Front of drawer	595x213x15
07	1/1	02	Frente de gaveta Frente de cajón Front of drawer (Somente para C63-139)	595x217x15
08	1/1	04	Lado de gaveta Lado del cajón Side of drawer	400x122x15
09=13	1/1	02	Fundo de gaveta Fondo de cajón Bottom of drawer	524x411x3
10	1/1	02	Ripa de trás Malla detrás Rear lath	543x122x15
11	1/1	01	Frente gaveta menor Frente del cajón menos Front of drawer smaller	595x136x15
11	1/1	01	Frente de gaveta menor Frente del cajón menos Front of drawer smaller (Somente para C63-139)	595x140x15
12	1/1	02	Lado de Gaveta menor Lado del cajón menor Smallest Drawer Side	400x90x15
13=09	1/1	01	Fundo de gaveta Fondo de cajón Bottom of drawer	524x411x3
14	1/1	01	Ripa de trás menor Listón trasero menos Rear lath smaller	543x90x15

AVISO
Para limpeza de seu móvel, use uma flanela seca ou umedecida, e não utilize produtos químicos que possam danificar seu produto.

SISTEMA DE MONTAGEM
O sistema de montagem dos produtos, funciona de acordo com a ordem crescente dos números indicados no desenho. Ex: 01, 02, 03, 04... até a conclusão da montagem.

ASSISTÊNCIA TÉCNICA
Para solicitação de Assistência Técnica você consumidor deverá entrar em contato com o Lojista o qual você realizou a compra deste produto e solicitar a assistência técnica das peças avariadas. A garantia abrange todas as peças, partes e componentes que eventualmente venham apresentar defeito de fabricação no prazo de 03 (três) meses, contando a partir da entrega do produto ao consumidor, mediante nota fiscal de compra. Se houver qualquer alteração na estrutura do produto ou ocorrer defeito por negligência do montador/consumidor em relação a instrução de montagem e manuseio, não será fornecido assistência técnica gratuita.

ADVERTENCIA
Para limpieza de su móvil, use una flanela seca o húmeda, y no utilice productos químicos que puedan dañar su producto.

SISTEMA DE MONTAJE
El sistema de montaje de los productos funciona de acuerdo con el orden creciente de los números indicados en el dibujo. Ej.: 01, 02, 03, 04... hasta la conclusión del montaje.

ASSISTÊNCIA TÉCNICA
Para solicitar Assistência Técnica, el consumidor debe comunicarse con el Comercio que usted realizó la compra de este producto y solicita asistencia técnica para las partes dañadas. La garantía cubre todas las partes, piezas y componentes que eventualmente puedan presentar defecto de fabricación en el plazo de 03 (tres) meses, contados a partir de la entrega del producto al consumidor, mediante factura de compra. Si se produce algún cambio en la estructura del producto o se produce un defecto por negligencia del montador/consumidor en relación con las instrucciones de montaje y manipulación, no se prestará asistencia técnica gratuita.

NOTICE
To clean your furniture, use a dry or wet cloth, and do not use chemicals that may damage your product.

ASSEMBLY SYSTEM
The products' assembly system works according to the increasing order of the indicated numbers. For example: 01, 02, 03, 04... to the end of the assembly.

TECHNICAL ASSISTANCE
To request Technical Assistance, the consumer must contact the retailer from whom you purchased this product and request technical assistance for the damaged parts. The warranty covers all parts, parts and components that may eventually present a manufacturing defect within a period of 03 (three) months, counting from the delivery of the product to the consumer, by means of a purchase invoice. If there is any change in the structure of the product or defect occurs due to negligence of the assembler/consumer in relation to the assembly and handling instruction, free technical assistance will not be provided.

Ferragens | Herrajes | Hardware

A Parafuso 7,0x40mm CHT. Tornillo 7,0x40mm CHT. Screw 7,0x40mm CHT.	B Parafuso 5,0x50mm FLA. Tornillo 5,0x50mm FLA. Screw 5,0x50mm FLA.	C Parafuso 4,5x50mm CHT. Tornillo 4,5x50mm CHT. Screw 4,5x50mm CHT.	D Parafuso União 30mm Tornillo Unión 30mm Union Screw 30mm	E Parafuso 3,5x40mm CHT. Tornillo 3,5x40mm CHT. Screw 3,5x40mm CHT.	F Adesivo tapa parafuso 10mm Adhesivo tapón de tornillo 10mm Bolt cover adhesive 10mm	G Parafuso 4,0x14mm CHT. Tornillo 4,0x14mm CHT. Screw 4,0x14mm CHT.	H Parafuso 3,5x12mm CHT. Tornillo 3,5x12mm CHT. Screw 3,5x12mm CHT.
I Kit Pontaíra Plástica MOV4083 Kit de punta de plástico MOV4083 Plastic Tip Kit MOV4083	J Parafuso 3,0x30mm CHT. Tornillo 3,0x30mm CHT. Screw 3,0x30mm CHT.	K Cavilha 8x25mm Cinta 8x25mm Dowel 8x25mm	L Divisor talheres 511x398mm Divisor cubiertos 511x398mm Cutlery divider 511x398mm	M Prego 10x10mm Clavo 10x10mm Nail 10x10mm	N Cantoneira plástica Cantoneira plástica Plastic angle brackets	O Pé 145mm x 42mm Pie 145mm x 42mm Foot 145mm x 42mm	P Cantoneira suporte triangular Cantoneira soporte triangular Triangle support angle
Q Puxador MOV 595mm Tirador MOV 595mm MOV 595mm Handle	R Corrediza telescópica Diapositivas telescópicas Telescopic slides	S Perfil "H" 580mm Perfil "H" 580mm Profile "H" 580mm	T Sachê de cola Bolsa de pegamento Glue bag	U Suporte de fixação Soporte de fijación Mounting bracket	V Proteção para cantoneira Ángulo de protección Protection angle	W Buchsa plástica 8mm Buchsa de plástico 8mm 8mm plastic bushing	X Batente PVC para Porta Parada de PVC para Puerta PVC Door Stop
Y Puxador MOV4083 - 591mm Tirador MOV4083 - 591mm MOV4083 - 591mm Handle							

RECOMENDAÇÃO

Para fixar o móvel na parede usar o suporte de fixação (U), o parafuso 4,0x14mm CHT (G), a Buchsa 8mm (W) e o parafuso 5,0x50mm FLA (B).

RECOMENDACIÓN

Para conectar el móvil a la pared con el soporte (U), tornillo 4,0x14mm CHT (G), el casquillo de 8 mm (W) y el 5,0x50mm tornillo FLA (B).

RECOMMENDATION

To fix the furniture to the wall use the mounting bracket (U), the 4.0x14mm CHT (G) screw, the 8mm bushing (W) and the 5.0x50mm FLA screw (B).

Somente para (C63-139)

Solo para (C63-139)

Only for (C63-139)

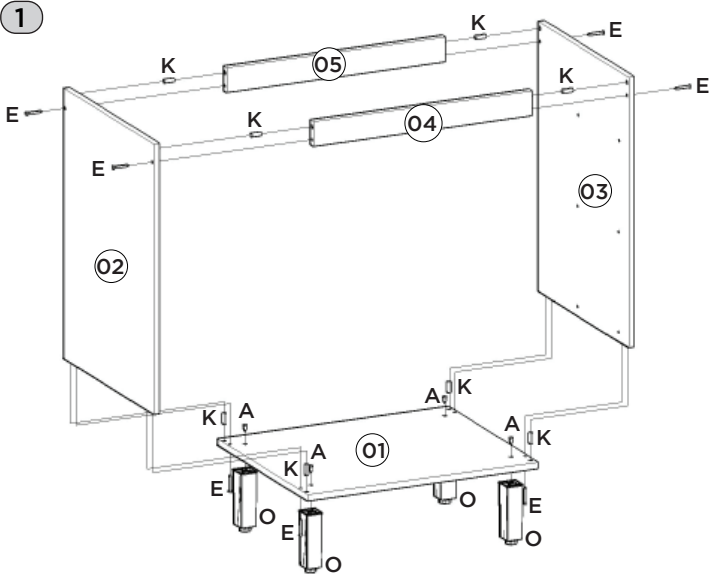

Utilizar o sachê de cola (T) em todas as cavilhas (K) do produto.

Con el pegamento sobre (T) en todos los pernos (K) producto.

Use the glue sachet (T) on all the pegs (K) of the product.

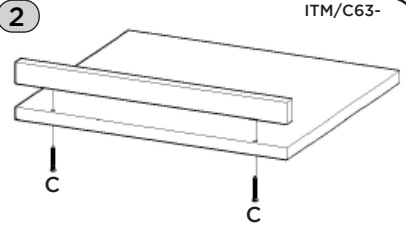

Esse tampo é opcional e é vendido separadamente (C903-33).

Esta vez es opcional y se vende por separado (C903-33).

This top is optional and is sold separately (C903-33).

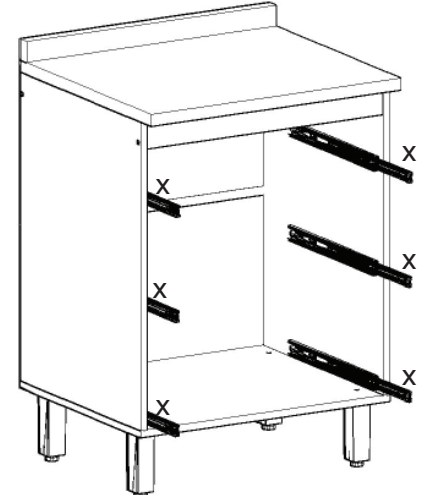
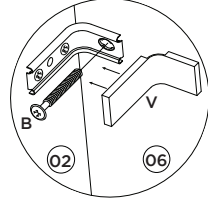
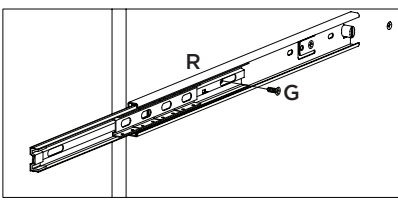
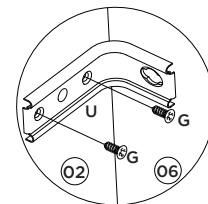
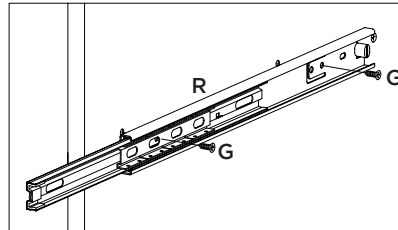
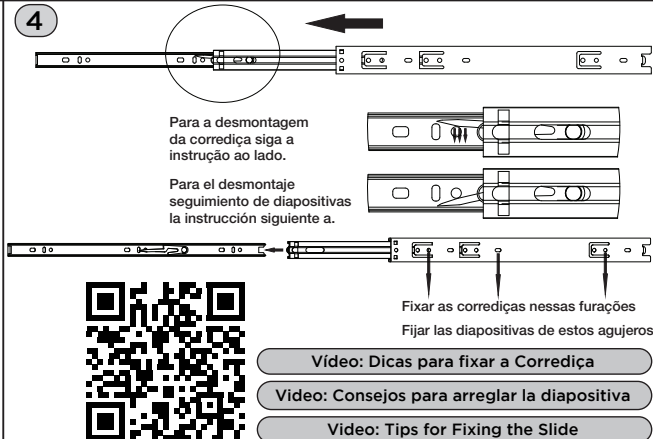
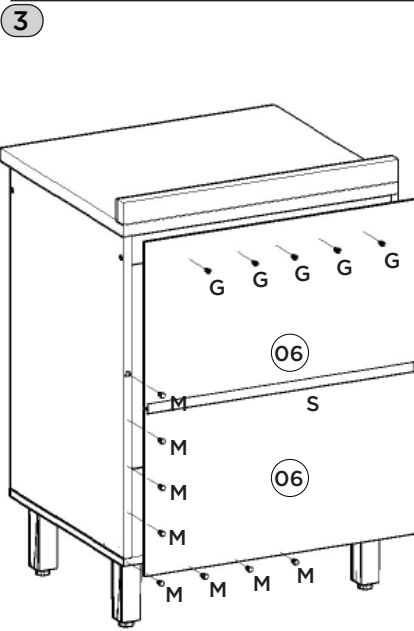
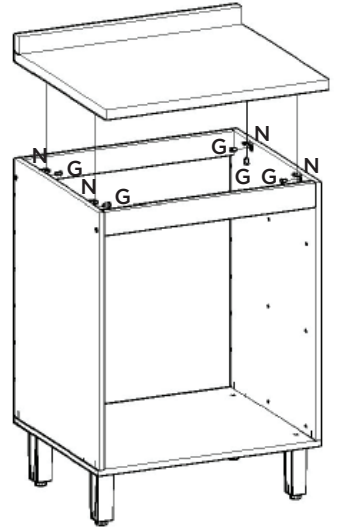

5 Montagem Gavetas / Montaje Gavetas / Drawers assembly

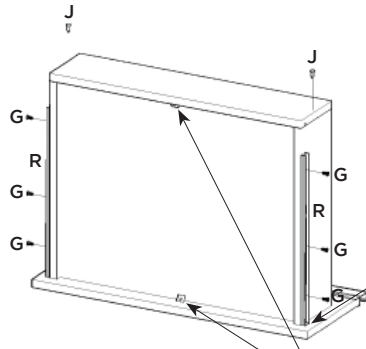
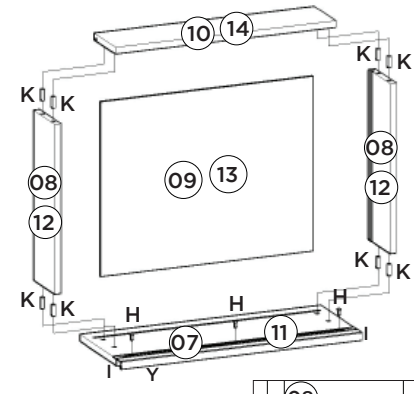
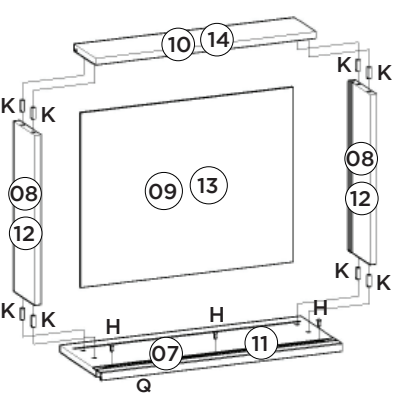

A correção (R) deverá ser alinhada com a parte de baixo do lado de gaveta (08 e 12).

La corredera (R) debe estar alineada con la parte de por el lado del cajón (08 y 12).

The slide (R) should be aligned with the bottom of the drawer side (08 and 12).

Deixar 3mm de distância da frente de gaveta.

Deje una separación de 3mm del frente del cajón.

Leave 3mm away from the front of the drawer.

⚠ Somente para (C63-139)
Solo para (C63-139)
Only for (C63-139)

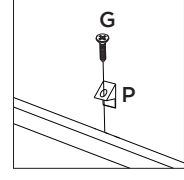
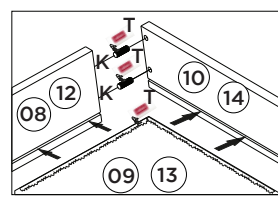
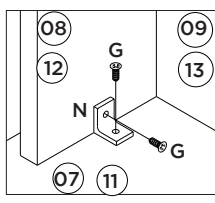
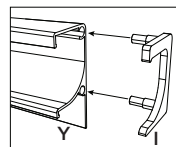

HENNInd. e Com. de Móveis Henn
Mondai - SC - Brasil

☎+55 49 3674.3500

📧@moveishenn
www.henn.com.br**INSTRUÇÕES DE MONTAGEM****INSTRUCCIONES DE MONTAJE
ASSEMBLY INSTRUCTIONS****BALCÃO 2 PORTAS 800MM CONNECT | BALCÓN 2 PUERTAS 800MM CONNECT |
BALCONY 2 DOORS 800MM CONNECT****Referência/Cor**

- C64-35 - Duna/Cristal
 C64-42 - Fendi
 C64-139 - Off White

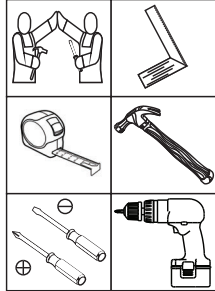
**Requisitos para montagem
Requisitos para la montaje
Assembly Requirements**

Imagens meramente ilustrativas, não acompanha o produto.
 Imágenes ilustrativas, no incluidas con el producto.
 Illustrative images, not included with the product.

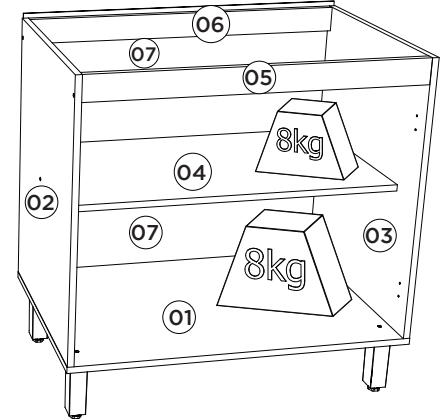
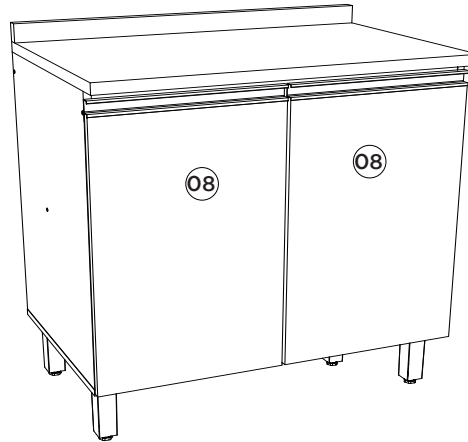

**Pesos máximos recomendados com carga distribuída
 Peso máximo recomendado con la carga distribuida
 Recommended maximum weights with evenly distributed.**

Lista de Peças | Lista de piezas | List of parts

Item	Caixa Caja Box	Qtd Ctd Qty	Descrição Descripción Description	Medidas (mm) Dimensions (mm) Size (measurements) (mm)
01	1/1	01	Base Base Base	800x490x15
02	1/1	01	Lateral esquerda Lateral izquierda Left side	660x490x15
03	1/1	01	Lateral direita Lateral derecha Right side	660x490x15
04	1/1	01	Prateleira Estante Shelf	768x400x15
05	1/1	01	Travessa frontal Travesaño frontal Front crossbar	768x60x15
06	1/1	01	Travessa traseira Travesaño trasero Rear bumper	768x60x15
07	1/1	02	Fundo Fondo Bottom	792x341x3
08	1/1	02	Porta Puerta Door	625x396x15
08	1/1	02	Porta Puerta Door (Somente para C64-139)	629x396x15

AVISO

Para limpeza de seu móvel, use uma flanela seca ou umedecida, e não utilize produtos químicos que possam danificar seu produto.

SISTEMA DE MONTAGEM

O sistema de montagem dos produtos, funciona de acordo com a ordem crescente dos números indicados no desenho. Ex: 01, 02, 03, 04... até a conclusão da montagem.

ASISTENCIA TÉCNICA

Para solicitação de Assistência Técnica você consumidor deverá entrar em contato com o Lojista a qual você realizou a compra deste produto e solicitar a assistência técnica das peças avariadas. A garantia abrange todas as peças, partes e componentes que eventualmente venham apresentar defeito de fabricação no prazo de 03 (três) meses, contando a partir da entrega do produto ao consumidor, mediante nota fiscal de compra. Se houver qualquer alteração na estrutura do produto ou ocorrer defeito por negligência do montador/consumidor em relação a instrução de montagem e manuseio, não será fornecido assistência técnica gratuita.

ADVERTENCIA

Para limpieza de su móvil, use una flanela seca o húmeda, y no utilice productos químicos que puedan dañar su producto.

SISTEMA DE MONTAJE

El sistema de montaje de los productos funciona de acuerdo con el orden creciente de los números indicados en el dibujo. Ej: 01, 02, 03, 04... hasta la conclusión del montaje.

ASISTENCIA TÉCNICA

Para solicitar Asistencia Técnica, el consumidor debe comunicarse con el Comercio que usted realizó la compra de este producto y solicita asistencia técnica para las partes dañadas. La garantía cubre todas las partes, piezas y componentes que eventualmente puedan presentar defecto de fabricación en el plazo de 03 (tres) meses, contados a partir de la entrega del producto al consumidor, mediante factura de compra. Si se produce algún cambio en la estructura del producto o se produce un defecto por negligencia del montador/consumidor en relación con las instrucciones de montaje y manipulación, no se prestará asistencia técnica gratuita.

NOTICE

To clean your furniture, use a dry or wet cloth, and do not use chemicals that may damage your product.

ASSEMBLY SYSTEM

The products' assembly system works according to the increasing order of the indicated numbers. For example: 01, 02, 03, 04 ... to the end of the assembly.

TECHNICAL ASSISTANCE

To request Technical Assistance, the consumer must contact the retailer from whom you purchased this product and request technical assistance for the damaged parts. The warranty covers all parts, parts and components that may eventually present a manufacturing defect within a period of 03 (three) months, counting from the delivery of the product to the consumer, by means of a purchase invoice. If there is any change in the structure of the product or defect occurs due to negligence of the assembler/consumer in relation to the assembly and handling instruction, free technical assistance will not be provided.

Ferragens | Herrajes | Hardware

A Parafuso 7,0x40mm CHT. Tornillo 7,0x40mm CHT. Screw 7,0x40mm CHT.	B Parafuso 5,0x50mm FLA. Tornillo 5,0x50mm FLA. Screw 5,0x50mm FLA.	C Parafuso 4,5x50mm CHT. Tornillo 4,5x50mm CHT. Screw 4,5x50mm CHT.	D Parafuso 3,5x40mm CHT. Tornillo 3,5x40mm CHT. Screw 3,5x40mm CHT.	E Parafuso 4,0x14mm FLA. Tornillo 4,0x14mm FLA. Screw 4,0x14mm FLA.	F Parafuso 3,5x12mm CHT. Tornillo 3,5x12mm CHT. Screw 3,5x12mm CHT.	G Parafuso União 30mm Tornillo Unión 30mm Union Screw 30mm	H Cavilha 8x25mm Cinta 8x25mm Dowel 8x25mm
I Prego 10x10mm Clavo 10x10mm Nail 10x10mm	J Fixador de fundos Fijador de fondos Bottom fixer	K Cantoneira plástica Cantenera plástica Plastic angle brackets	L Pé 145mm x 42mm Pie 145mm x 42mm Foot 145mm x 42mm	M Puxador MOV 396mm Tirador MOV 396mm MOV 396mm Handle	N Dobradica 35mm POP Banca e Amort + Calço Fixo Bisagra base POP de 35 mm con amortiguación + calzo fijo 35mm POP Low Hinge with Damping + Fixed Shim	O Adesivo tapa parafuso 17mm Adhesivo tapón de tornillo 17mm Bolt cover adhesive 17mm	P Batente PVC para Porta Parada de PVC para Puerta PVC Door Stop
Q Buchta plástica 8mm Buchta de plástico 8mm 8mm plastic bushing	R Suporte de fixação Soporte de fijación Mounting bracket	S Proteção para cantoneira Ángulo de protección Protection angle	T Giz de correção Tiza de corrección Chalk of correction	U Sachê de cola Bolsa de pegamento Glue bag	V Adesivo tapa parafuso 10mm Adhesivo tapón de tornillo 10mm Bolt cover adhesive 10mm	W Kit Ponteira Plástica MOV4083 Kit de punta de plástico MOV4083 Plastic Tip Kit MOV4083	X Puxador MOV4083 - 392mm Tirador MOV4083 - 392mm MOV4083 - 392mm Handle

O parafuso (G) deve ser usada somente quando este módulo for acoplado a outro módulo componível Henn.

El tornillo (G) se debe utilizar sólo cuando el módulo está conectado a otro módulo componible Henn.

The screw (G) should be used only when this module is attached to another Henn modular module.

RECOMENDAÇÃO

Para fixar o móvel na parede usar o suporte de fixação (R), o parafuso 4,0x14mm CHT (E), a Bucha 8mm (Q) e o parafuso 5,0x50mm FLA (B).

RECOMENDACIÓN

Para conectar el móvil a la pared con el soporte (R), tornillo 4,0x14mm CHT (E), el casquillo de 8 mm (Q) y el 5,0 x50mm tornillo FLA (B).

RECOMMENDATION

To fix the furniture to the wall use the mounting bracket (R), the 4.0x14mm CHT (E) screw, the 8mm bushing (Q) and the 5.0x50mm FLA (B).

1

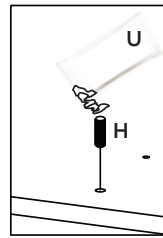
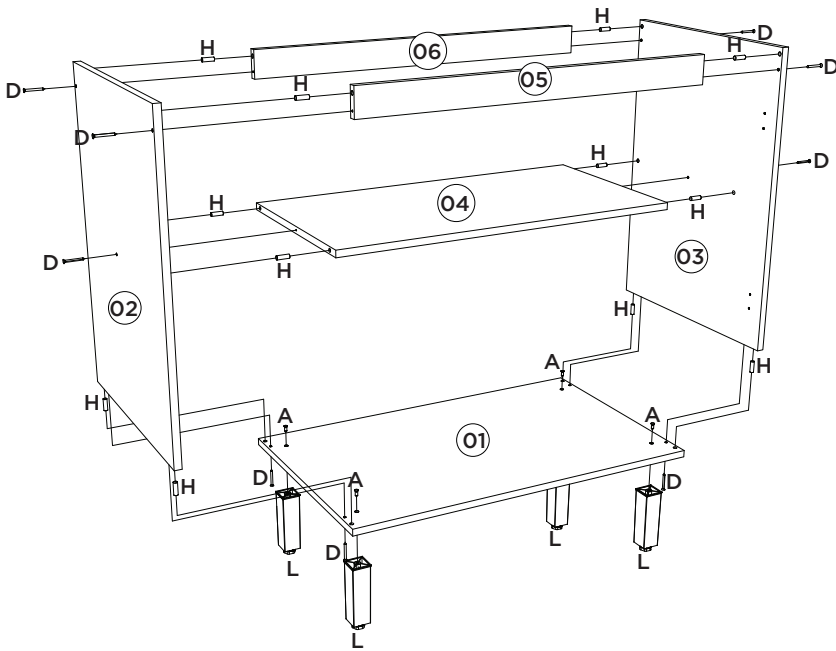

Utilizar o sachê de cola (U) em todas as cavilhas (H) do produto.

Con el pegamento sobre (U) en todos los pernos (H) producto.

Use the glue sachet (U) on all the pegs (H) of the product.

2

Esse tampo é opcional e é vendido separadamente (C904-33).

Esta vez es opcional y se vende por separado (C904-33).

This top is optional and is sold separately (C904-33).

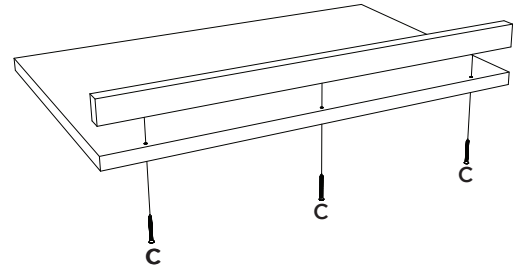

3

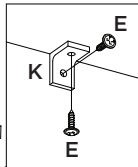
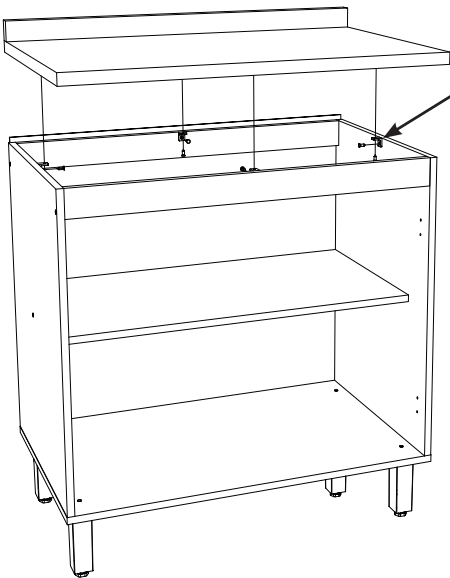

4

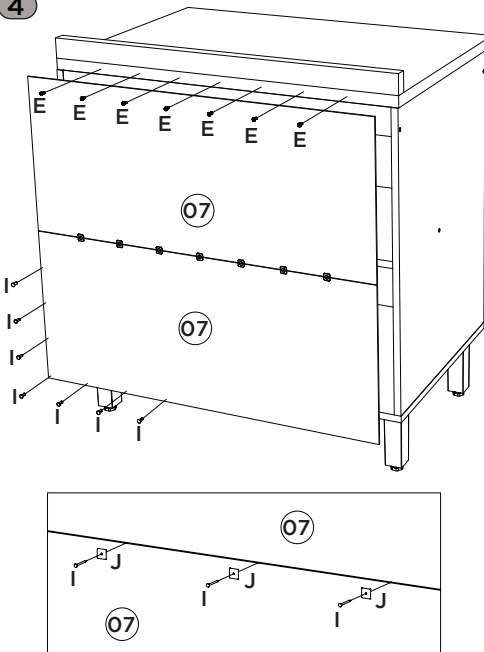

5

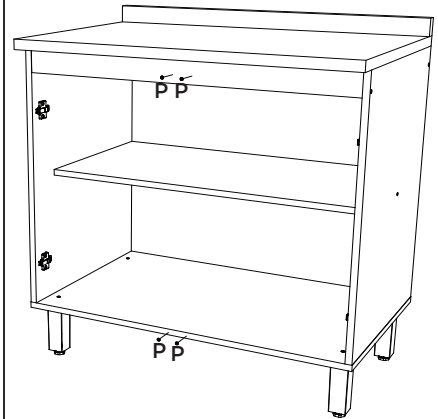

6

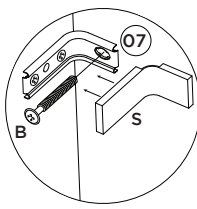
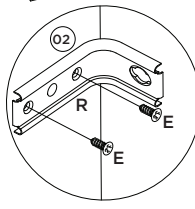
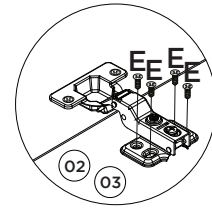
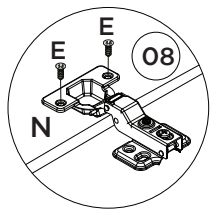
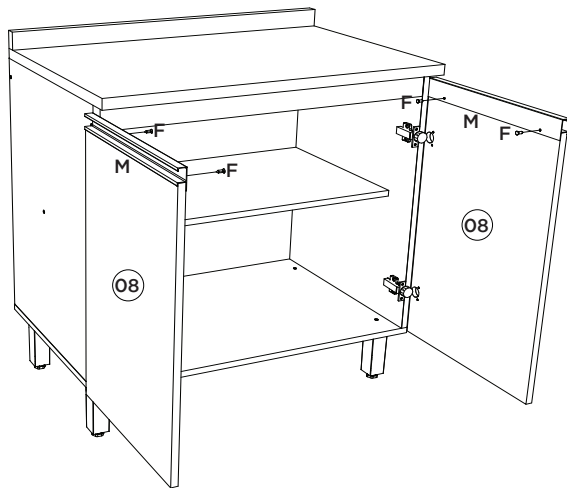

Somente para (C64-139)

Solo para (C64-139)

Only for (C64-139)

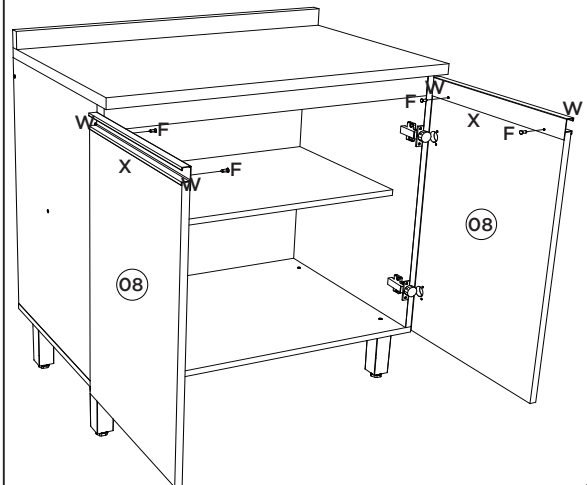
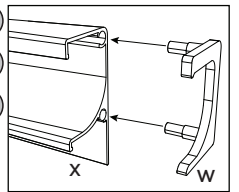

HENNInd. e Com. de Móveis Henn
Mondai - SC - Brasil

☎+55 49 3674.3500

📧📱@moveishenn
www.henn.com.br**INSTRUÇÕES DE MONTAGEM**INSTRUCCIONES DE MONTAJE
ASSEMBLY INSTRUCTIONS**Tampo para Balcão 600mm | Tablero para Balcón 600mm | Counter Top 600mm**

- C903-23 Duna
- C903-114 Calcare

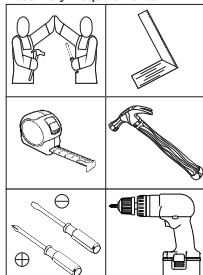
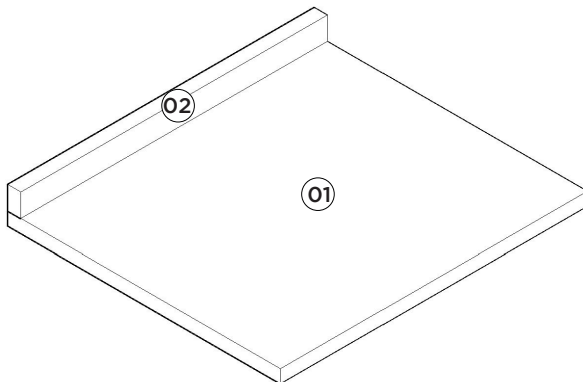
Requisitos para montagem
Requisitor para la montaje
Assembly RequirementsImagens meramente ilustrativas
Imágenes meramente ilustrativas
Images for illustration only**AVISO**

Para limpeza de seu móvel, use uma flanela seca ou umedecida, e não utilize produtos químicos que possam danificar seu produto.

SISTEMA DE MONTAGEM

O sistema de montagem dos produtos, funciona de acordo com a ordem crescente dos números indicados no desenho. Ex: 01, 02, 03, 04... até a conclusão da montagem.

ADVERTENCIA

Para limpieza de su móvil, use una franela seca o húmeda, y no utilice productos químicos que puedan dañar su producto.

SISTEMA DE MONTAJE

El sistema de montaje de los productos funciona de acuerdo con el orden creciente de los números indicados en el dibujo. Ej.: 01, 02, 03, 04... hasta la conclusión del montaje.

NOTICE

To clean your furniture, use a dry or wet cloth, and do not use chemicals that may damage your product.

ASSEMBLY SYSTEM

The products' assembly system works according to the increasing order of the indicated numbers. For example: 01, 02, 03, 04 ... to the end of the assembly.

Lista de Peças | Lista de piezas | List of parts

Item	Caixa Caja Box	Qtd Ctd Qty	Descrição Descripción Description	Medidas (mm) Dimensiones (mm) Size (measurements) (mm)
01	1/1	01	Tampo Tapa Top	600x533x25
02	1/1	01	Rodatampo Rodatampo Rodatampo	600x45x25

Ferragens | Herrajes | Hardware

A	02x	B	08x	C	04x
Parafuso 4,5x50mm CHT. Tornillo 4,5x50mm CHT. Screw 4,5x50mm CHT.		Parafuso 3,5x14mm FLA. Tornillo 3,5x14mm FLA. Screw 3,5x14mm FLA.		Cantoneira plástica Cantонера plástica Plastic angle brackets	

⚠ Estas ferragens constam no Pacote do respectivo Balcão.
Estos herrajes constan en el Paquete del respectivo Balcón.
These hardware are included in the Package of the respective Counter.

Esse tampo é opcional e é vendido separadamente

Esta vez es opcional y se vende por separado

This top is optional and is sold separately

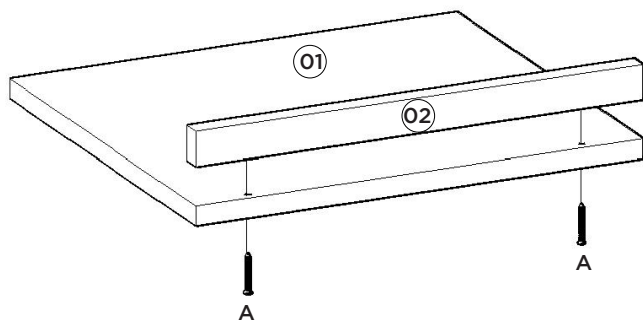

Exemplo de como fixar o Tampo no produto.

Ejemplo de la fijación de la tapa sobre el producto.

Example of fixing the lid on the product.

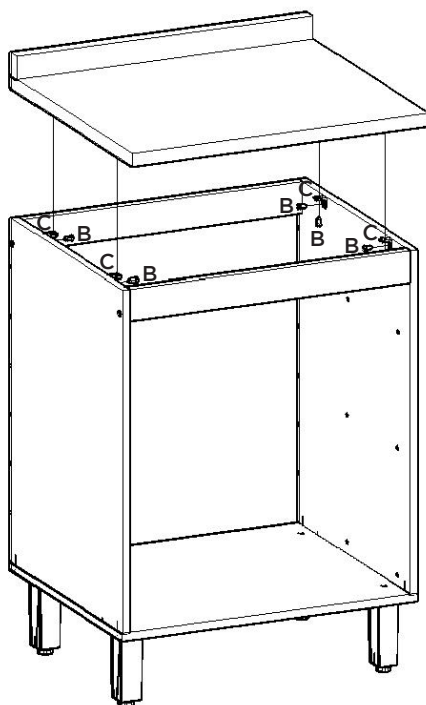

HENNInd. e Com. de Móveis Henn
Mondai - SC - Brasil

☎ +55 49 3674.3500

📱 @moveishenn
www.henn.com.br**INSTRUÇÕES DE
MONTAGEM****INSTRUCCIONES DE MONTAJE
ASSEMBLY INSTRUCTIONS****Aéreo Micro-ondas 600mm Connect | Aire Microondas 600mm Connect |
Aerial Microwave 600mm Connect****Referência/Cor**

- C428-23 - Duna
 C428-139 - Off White

Requisitos para montagem
Requisitos para la montaje
Assembly Requirements

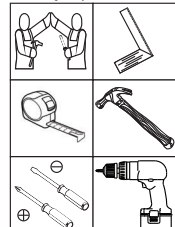

Imagens meramente ilustrativas, não
acompanha o produto.
Imágenes ilustrativas, no incluidas con
el producto.
Illustrative images, not included with
the product.

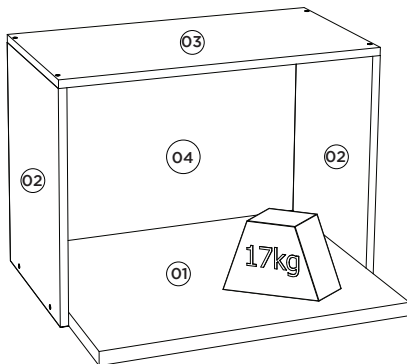

**Pesos máximos recomendados com carga distribuída
Peso máximo recomendado con la carga distribuída
Recommended maximum weight with distributed load.**

Lista de Peças | Lista de piezas | List of parts

Item	Caixa Caja Box	Qtd Ctd Qty	Descrição Descripción Description	Medidas (mm) Dimensions (mm) Size (measurements) (mm)
01	1/1	01	Base Base Base	570x400x25
02	1/1	02	Lateral Direita Esquerda Lateral Derecha Izquierda Right Side Left	425x310x15
03	1/1	01	Tampo Tapa Top	600x310x15
04	1/1	01	Fundo Fondo Bottom	594x427x3

Ferragens | Herrajes | Hardware

A 02x Parafuso 5,0x50mm FLA. Tornillo 5,0x50mm FLA. Screw 5,0x50mm FLA.	B 08x Parafuso 3,5x40mm CHT. Tornillo 3,5x40mm CHT. Screw 3,5x40mm CHT.	C 18x Prego 10x10mm Clavo 10x10mm Nail 10x10mm	D 04x Parafuso 4,0x14mm CHT. Tornillo 4,0x14mm CHT. Screw 4,0x14mm CHT.	E 08x Cavilha 8x25mm Cinta 8x25mm Dowel 8x25mm
F 02x Bucha plástica 8mm Bucha de plástico 8mm 8mm plastic bushing	G 02x Suporte de fixação Soporte de fijación Mounting bracket	H 02x Proteção para cantoneira Ángulo de protección Protection angle	I 01x Sachê de cola Bolsa de pegamento Glue bag	J 10x Adesivo tapa parafuso 10mm Adhesivo tapón de tornillo 10mm Bolt cover adhesive 10mm
K 02x Parafuso União 30mm Tornillo Unión 30mm Union Screw 30mm				

O parafuso (K) deve ser usada somente quando este módulo for acoplado a outro módulo componível Henn.

El tornillo (K) se debe utilizar sólo cuando el módulo está conectado a otro módulo componible Henn.

The screw (K) should be used only when this module is attached to another Henn modular module.

RECOMENDAÇÃO

Para fixar o móvel na parede usar o suporte de fixação (G), o parafuso 4,0x14mm CHT (D), a Bucha 8mm (F) e o parafuso 5,0x50mm FLA (A).

RECOMENDACIÓN

Para conectar el móvil a la pared con el soporte (G), tornillo 4,0x14mm CHT (D), el casquillo de 8 mm (F) y el 5,0 x50mm tornillo FLA (A).

RECOMMENDATION

To fix the furniture to the wall use the fixing bracket (G), the 4.0x14mm CHT (D) screw, the 8mm bushing (F) and the 5.0x50mm FLA screw (A).

1

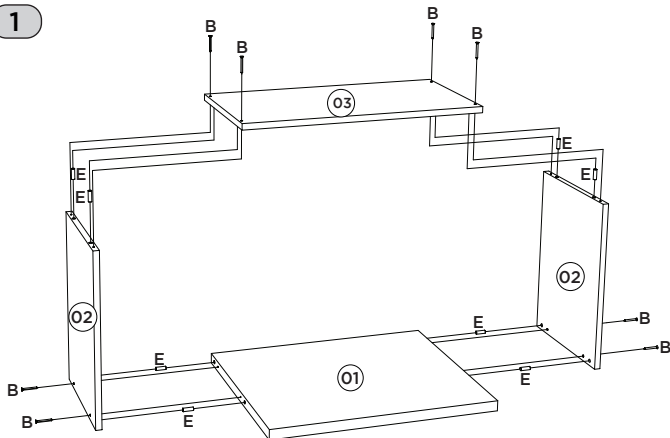

Utilizar o sachê de cola (I) em todas as cavilhas (E) do produto.

Con el pegamento sobre (U) en todos los pernos (E) producto.

Use the glue sachet (U) on all the pegs (E) of the product.

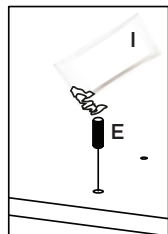

AVISO
Para limpeza de seu móvel, use uma flanela seca ou umedecida, e não utilize produtos químicos que possam danificar seu produto.

SISTEMA DE MONTAGEM
O sistema de montagem dos produtos, funciona de acordo com a ordem crescente dos números indicados no desenho. Ex: 01, 02, 03, 04... até a conclusão da montagem.

ASSISTÊNCIA TÉCNICA
Para solicitação de Assistência Técnica você consumidor deverá entrar em contato com o Lojista ou qual você realizou a compra deste produto e solicitar a assistência técnica das peças avariadas. A garantia abrange todas as peças, partes e componentes que eventualmente venham apresentar defeito de fabricação no prazo de 03 (três) meses, contando a partir da entrega do produto ao consumidor, mediante nota fiscal de compra. Se houver qualquer alteração na estrutura do produto ou ocorrer defeito por negligência do montador/consumidor em relação a instrução de montagem e manuseio, não será fornecido assistência técnica gratuita.

ADVERTENCIA
Para limpeza de su móvil, use una flanela seca o húmeda, y no utilice productos químicos que puedan dañar su producto.

SISTEMA DE MONTAJE
El sistema de montaje de los productos funciona de acuerdo con el orden creciente de los números indicados en el dibujo. Ej: 01, 02, 03, 04... hasta la conclusión del montaje.

ASISTENCIA TÉCNICA
Para solicitar Asistencia Técnica, el consumidor debe comunicarse con el Comercio que usted realizó la compra de este producto y solicita asistencia técnica para las partes dañadas. La garantía cubre todas las partes, piezas y componentes que eventualmente puedan presentar defecto de fabricación en el plazo de 03 (tres) meses, contados a partir de la entrega del producto al consumidor, mediante factura de compra. Si se produce algún cambio en la estructura del producto o se produce un defecto por negligencia del montador/consumidor en relación con las instrucciones de montaje y manipulación, no se prestará asistencia técnica gratuita.

NOTICE
To clean your furniture, use a dry or wet cloth, and do not use chemicals that may damage your product.

ASSEMBLY SYSTEM
The products' assembly system works according to the increasing order of the indicated numbers. For example: 01, 02, 03, 04 ... to the end of the assembly.

TECHNICAL ASSISTANCE
To request Technical Assistance, the consumer must contact the retailer from whom you purchased this product and request technical assistance for the damaged parts. The warranty covers all parts, parts and components that may eventually present a manufacturing defect within a period of 03 (three) months, counting from the delivery of the product to the consumer, by means of a purchase invoice. If there is any change in the structure of the product or defect occurs due to negligence of the assembler/consumer in relation to the assembly and handling instruction, free technical assistance will not be provided.

2

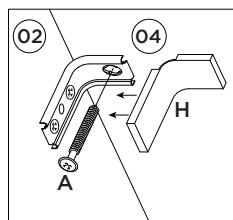
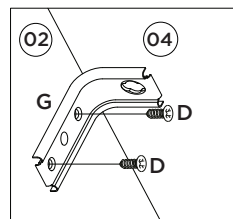
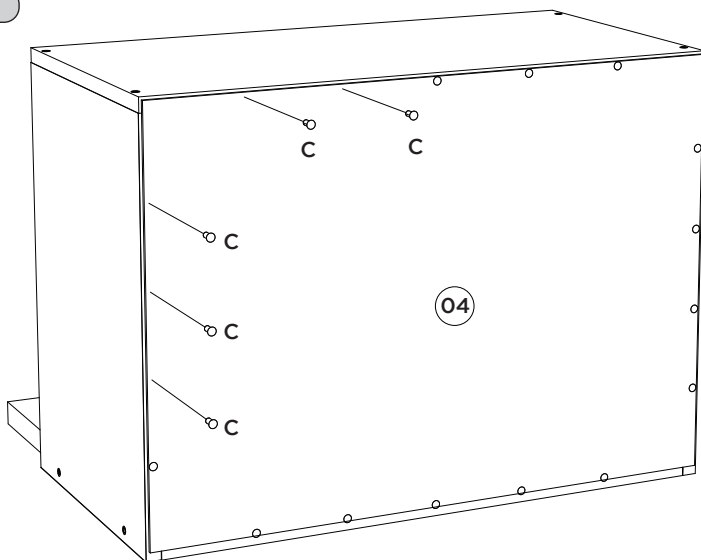

2