

Quiditá

Essência da qualidade

Móveis Quiditá
Bento Gonçalves - RS
Rodovia BR-470 KM 202 - Cep 95710-000
Fone: 0xx (54) 3458-1001
www.quiditamoveis.com.br

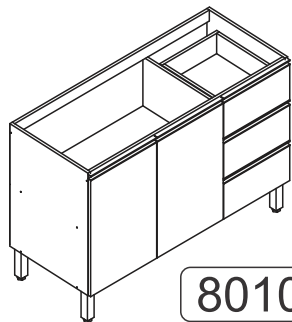

8010

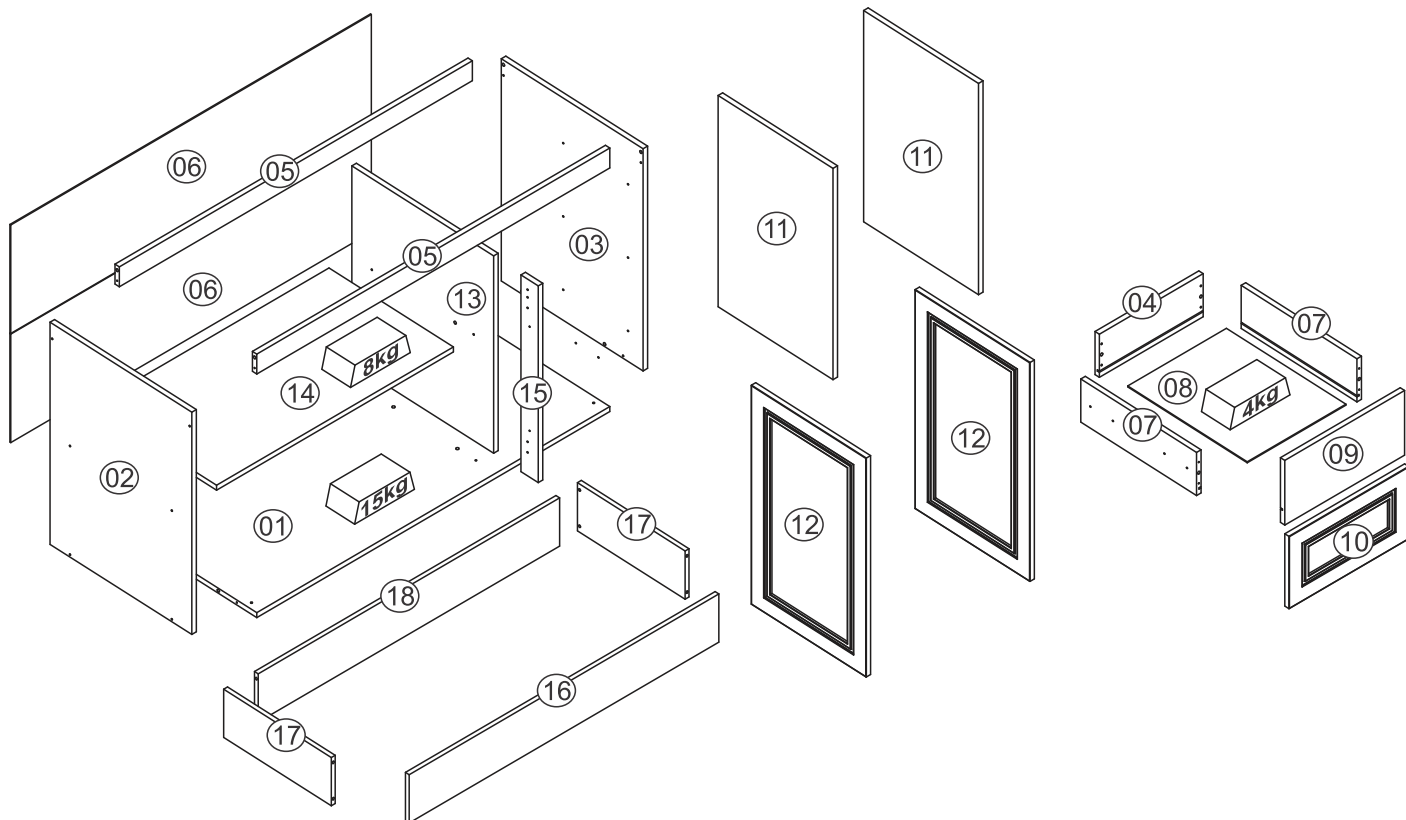

FERRAMENTAS NECESSÁRIAS
HERRAMIENTAS NECESARIAS
NECESSARY TOOLS/

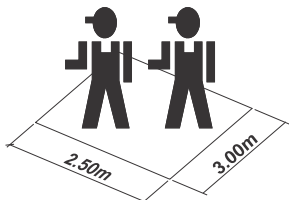
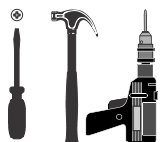













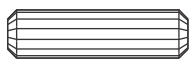

60 min





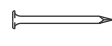

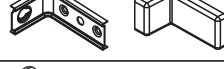

LISTA DE PEÇAS/RELACIÓN PIEZAS/PART LIST





Nº	Código Code	Descrição/Descripción/Description	Dimensão (mm) Dimensiones (mm) Measures (mm)	Qtde. Cantidad Quantity
01	801001	Base/Base/Base	1170 x 490 x 15	01
02	800003	Lateral esquerda/Left side/L teral izquierda	670 x 490 x 15	01
03	801002	Lateral direita/Right side/Lateral derecha	670 x 490 x 15	01
04	801008	Costa gaveta/Drawer back/Revés cajón	344 x 130x 15	03
05	801004	Travessa/Traverse/Travessaño	1770 x 60 x 15	02
06	801010	Costa/Revés/Back	1195 x 327 x 3	02
07	801007	Lateral gaveta/Drawer side/Lateral cajón	400 x 130 x 15	06
08	801011	Fundo gaveta/Drawer botom/Fondo cajón	413 x 327 x 3	03
09	801012	Frente gaveta/Drawer front/Frente cajón Ref. 8010	397 x 195 x 15	03
10	Q01307	Frente gaveta/Drawer front/Frente cajón Ref. 8210	218 x 397 x 15	03
11	800008	Porta/Door/Puerta Ref. 8010	637 x 397 x 15	02
12	Q01306	Porta/Door/Puerta Ref. 8210	660 x 397 x 15	02
13	801006	Divisão/Division/Divisória	595 x 490 x 15	01
14	801003	Prateleira/Shelf/Repisa	785 x 430 x 15	01
15	801005	Montante/Door traverse/Travessaño puerta	595 x 60 x 15	01
Ref. 8210				
16	811501	Rodapé frontal/Front baseboard/Zócalo delantero	1200 x 170 x 15	01
17	810501	Rodapé lateral/Side baseboard/Zócalo lateral	435 x 170 x 15	02
18	811502	Rodapé traseiro/Back baseboard/Zócalo de atras	1168 x 170 x 15	01

FERRAGENS/HERRAJES/HARDWARE

A			26
B		Cavilha/Tarugo/Dowel Ø8x30mm	26
C			98
D			04
E			04
F			05
G		Prego/Clavo/Nail 10x10	33
H		Bucha/Cojinete/Bush 8mm	04
I			04
J			14
K		Garra metálica/Pieza fijación revés/ Back claw 13x13	07

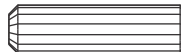
L		Sache cola/Pegamento/Glue	01
M			05
N		Puxador perfil/Tirador/Handle 397mm Ref. 8010	05
O		Puxador/Tirador/Handle Ref. 8210	05
P		Trilho telescópico/Trillo telescópico/Telescopic sliding 350mm	03
Q		Tapa furo/Tapa agujero/Hole sticker 12mm	16
R		Dobradiça/Bisagra Hinge 35mm	04

ROD1200

B		Cavilha/Tarugo/Dowel Ø8x30mm	08
C			40
J			20

1 Separação corredeira/Separación corredera/Sliding separation

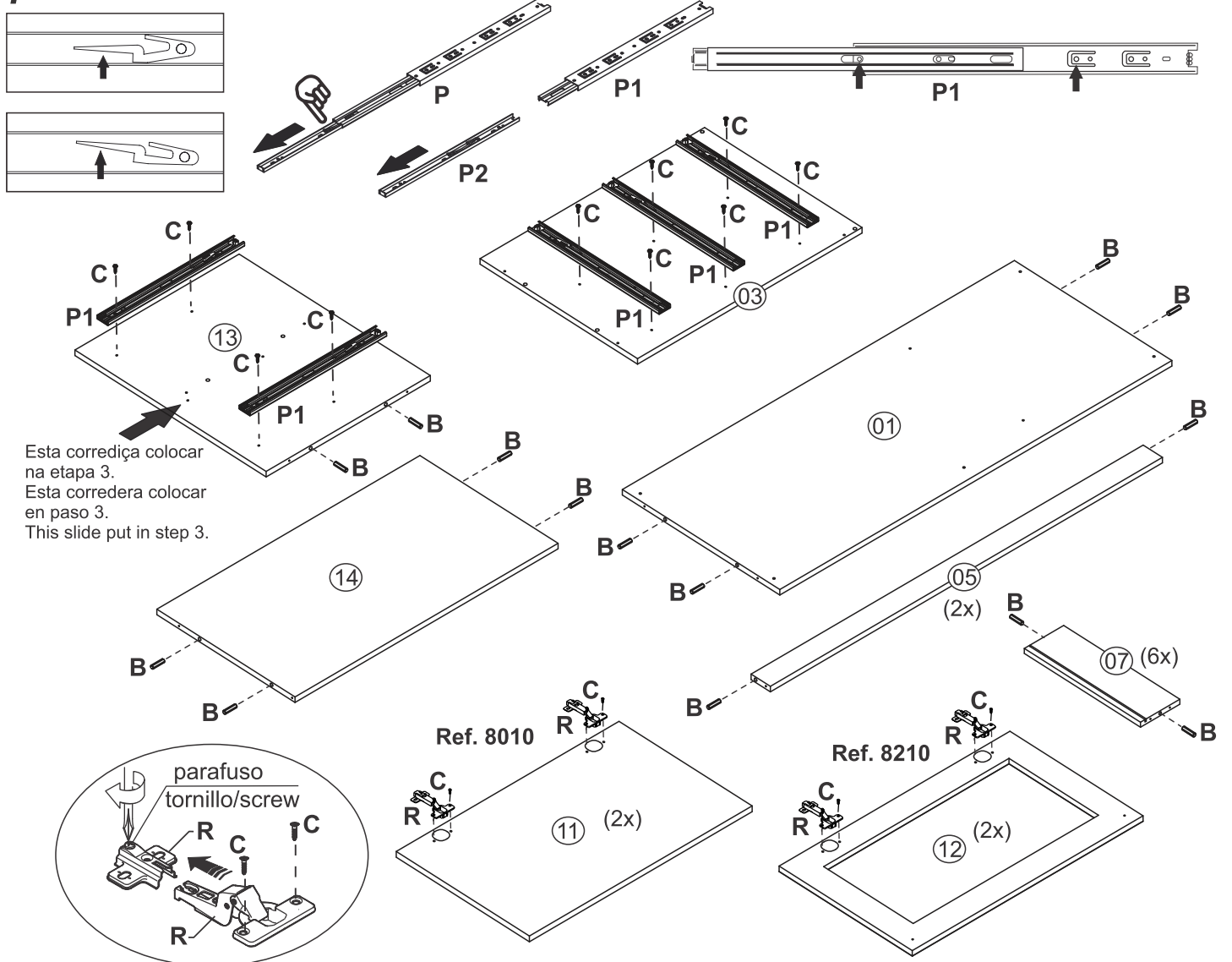

2

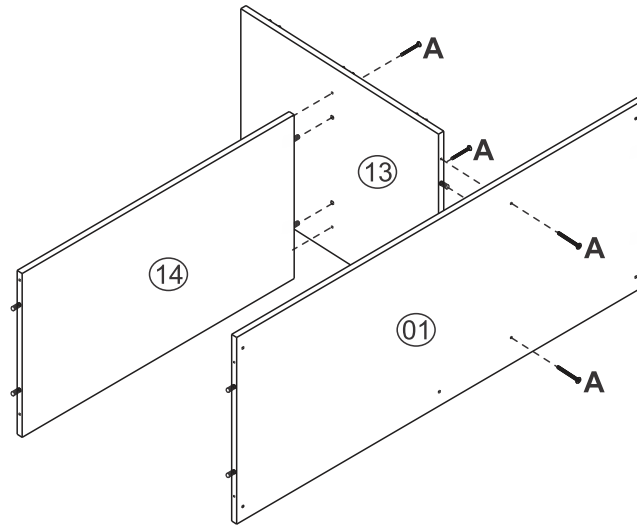

3

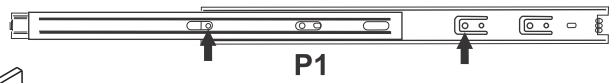
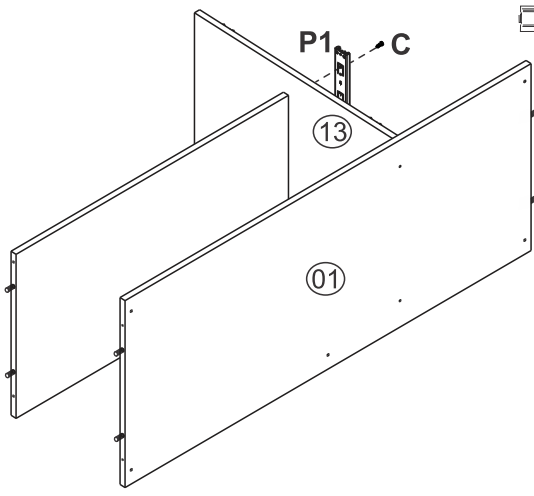

Fixar a corrediça central na divisão.
Fijar la corredera central en la divisoria.
Fix the central slide in the division.

4

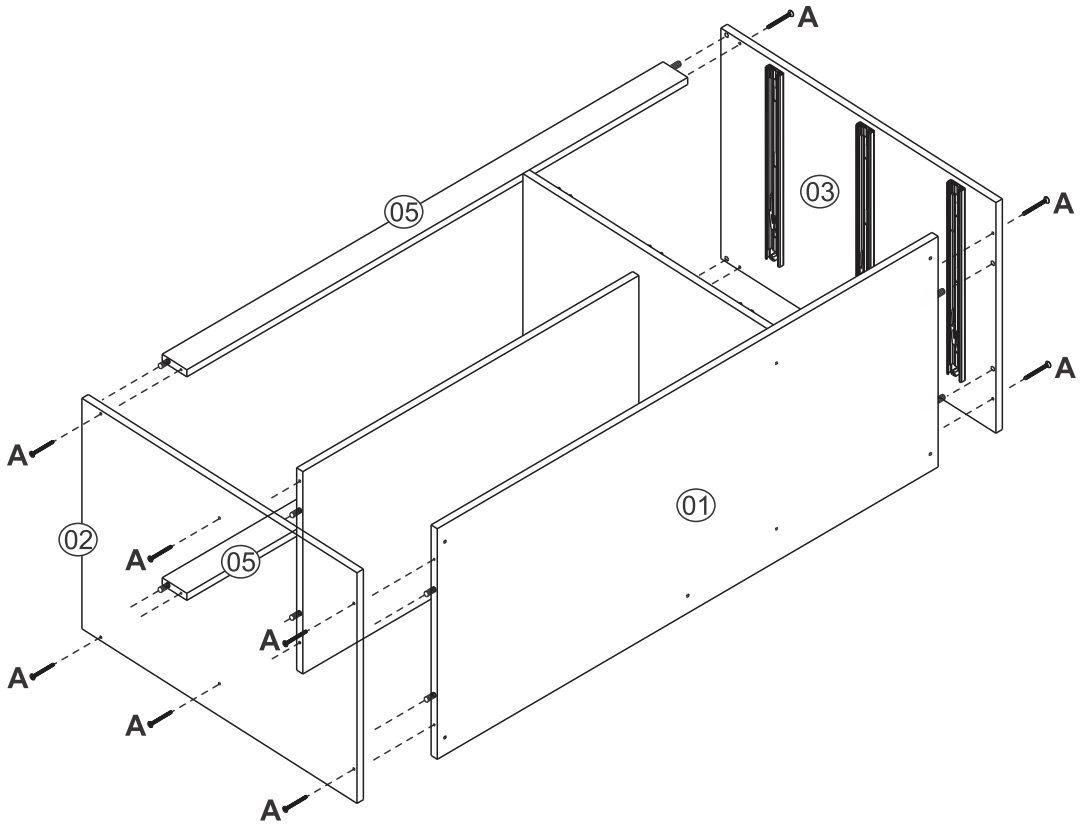

5 Ref. 8010

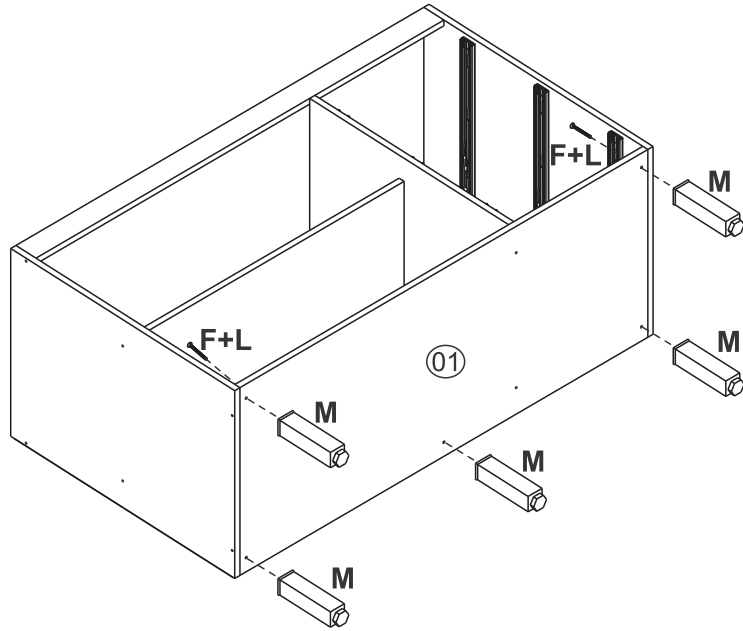

5 Ref. 8015

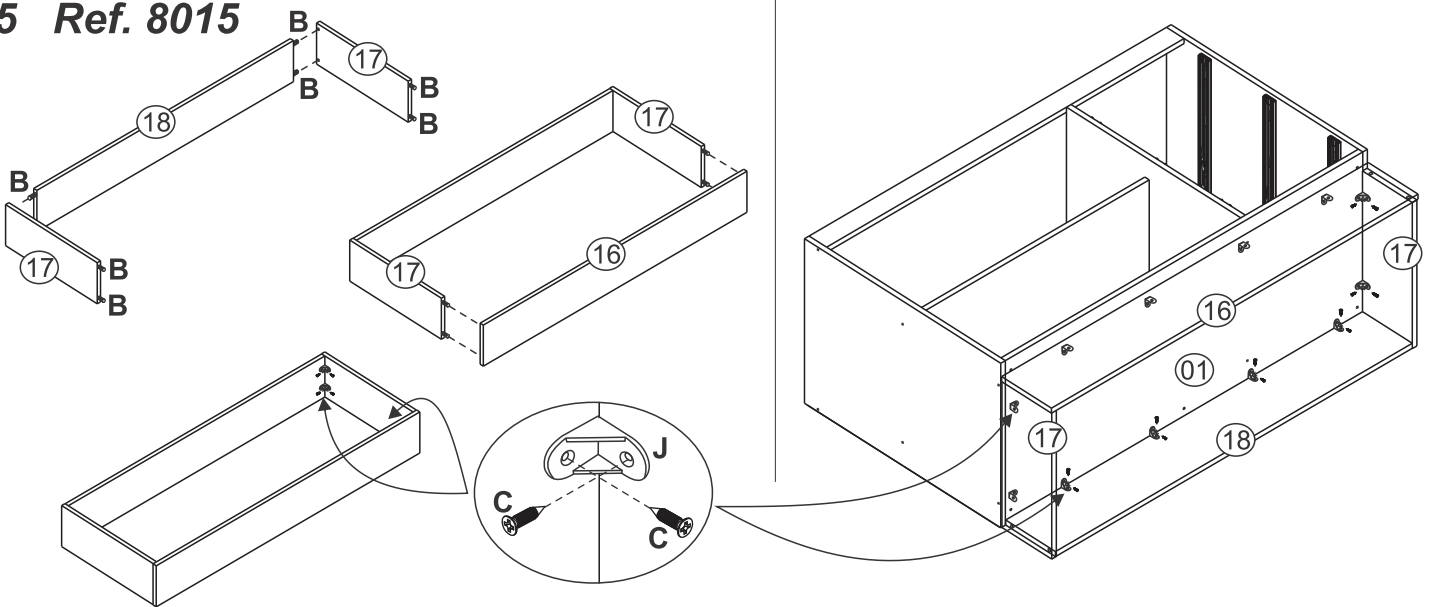

6 Ref. 8015/8215

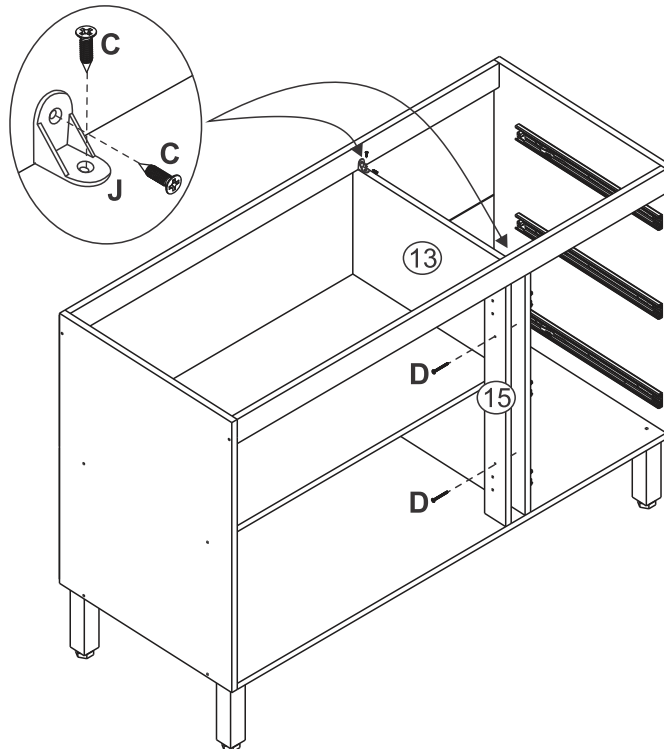

7

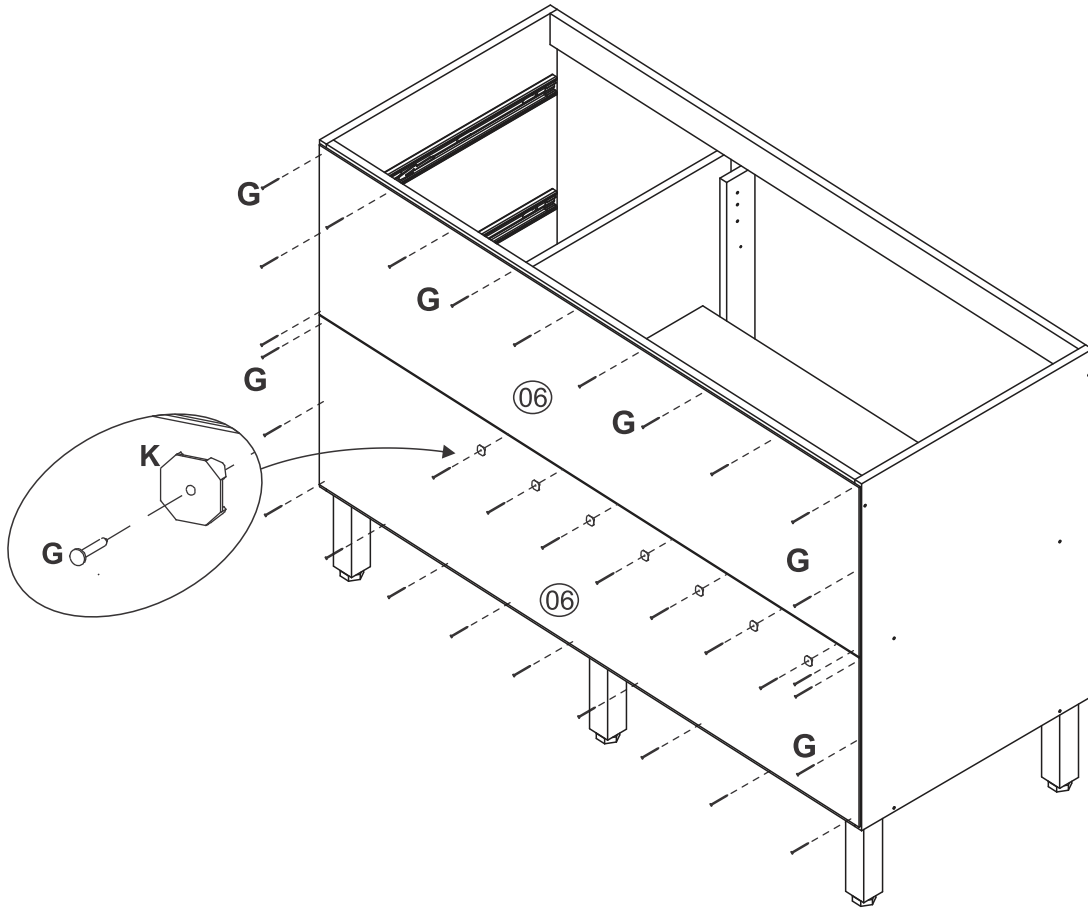

8 Fixação na parede - opcional
Fixing in the wall - optional
Fijación en pared - opcional

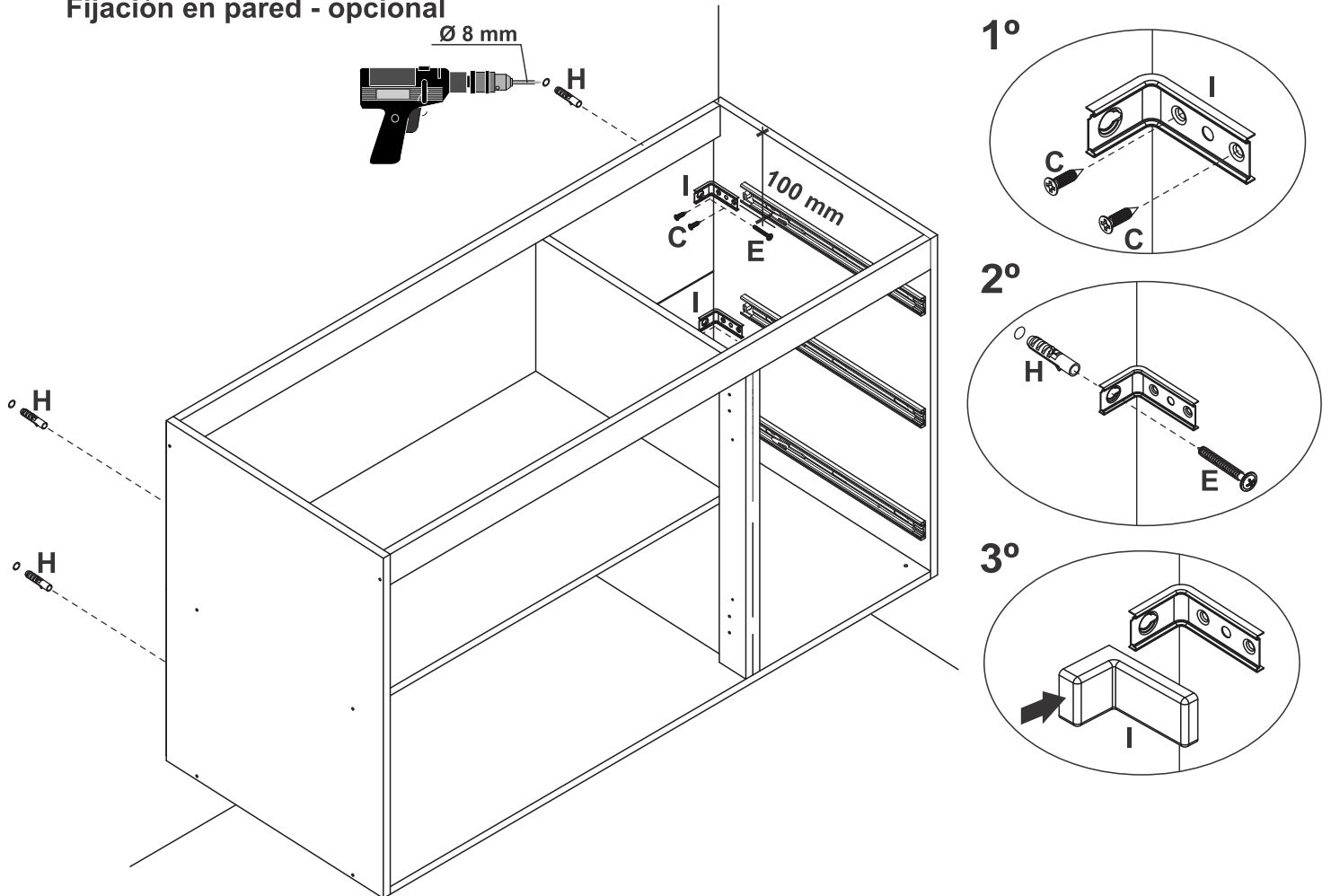

9

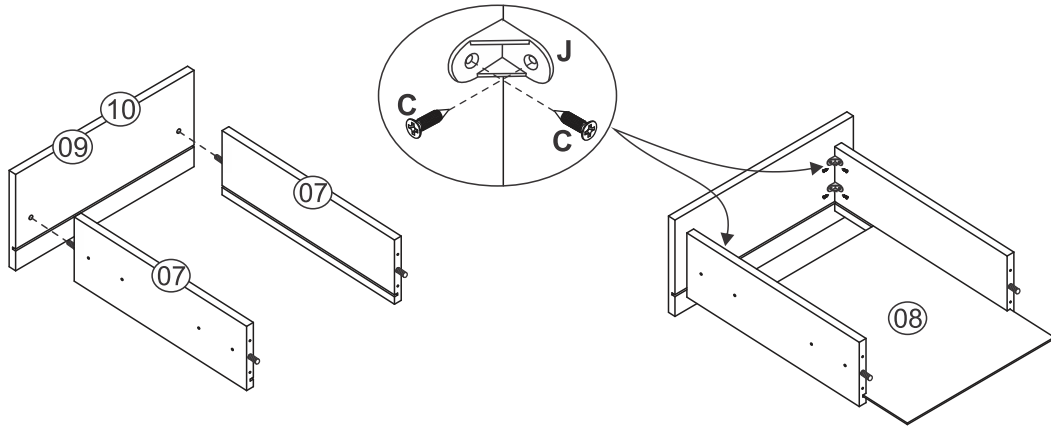

10

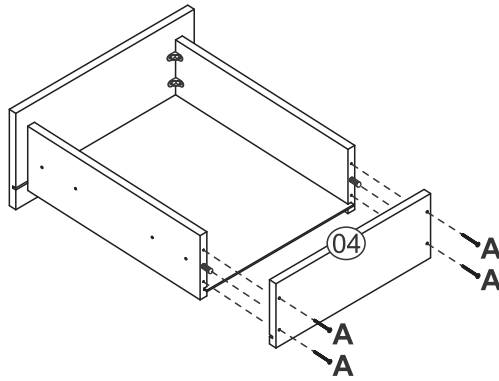

11

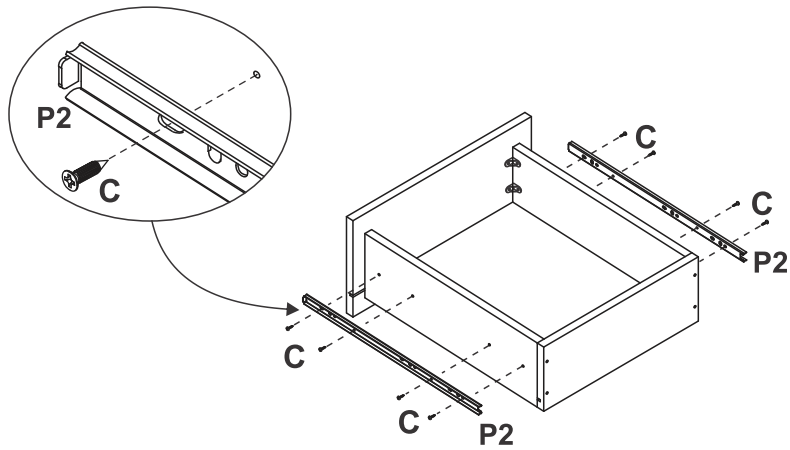

12

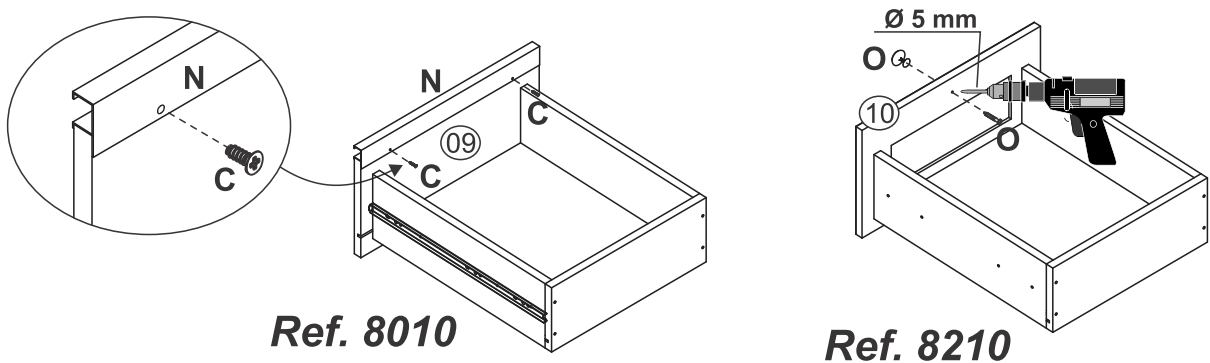

Ref. 8010

Ref. 8210

13 Posição de fixação do calço da dobradiça
Hinge base fixing position
Posición de fijación de la base de la bisagra

Ref. 8010

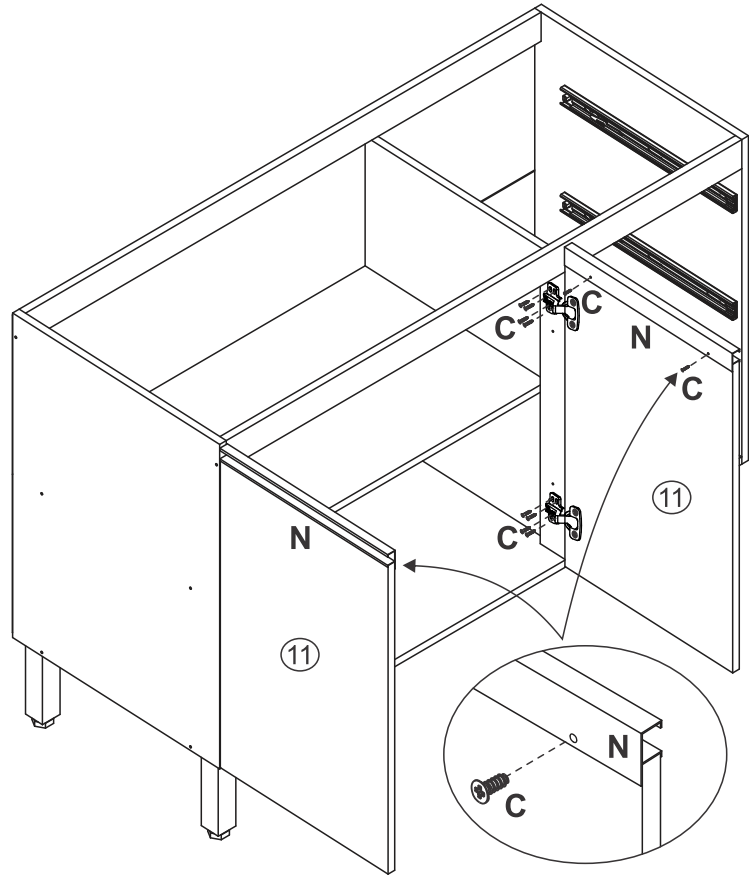
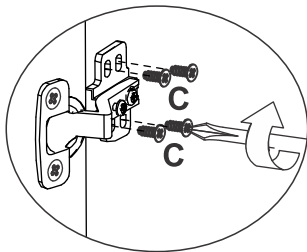
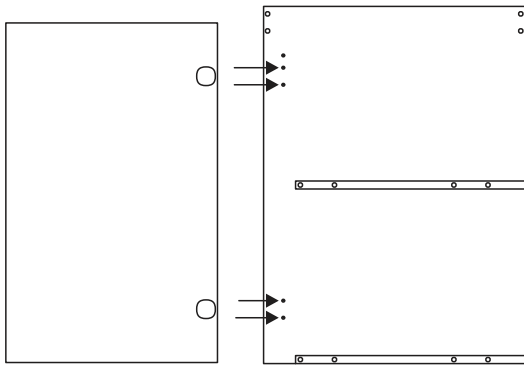

Ref. 8210

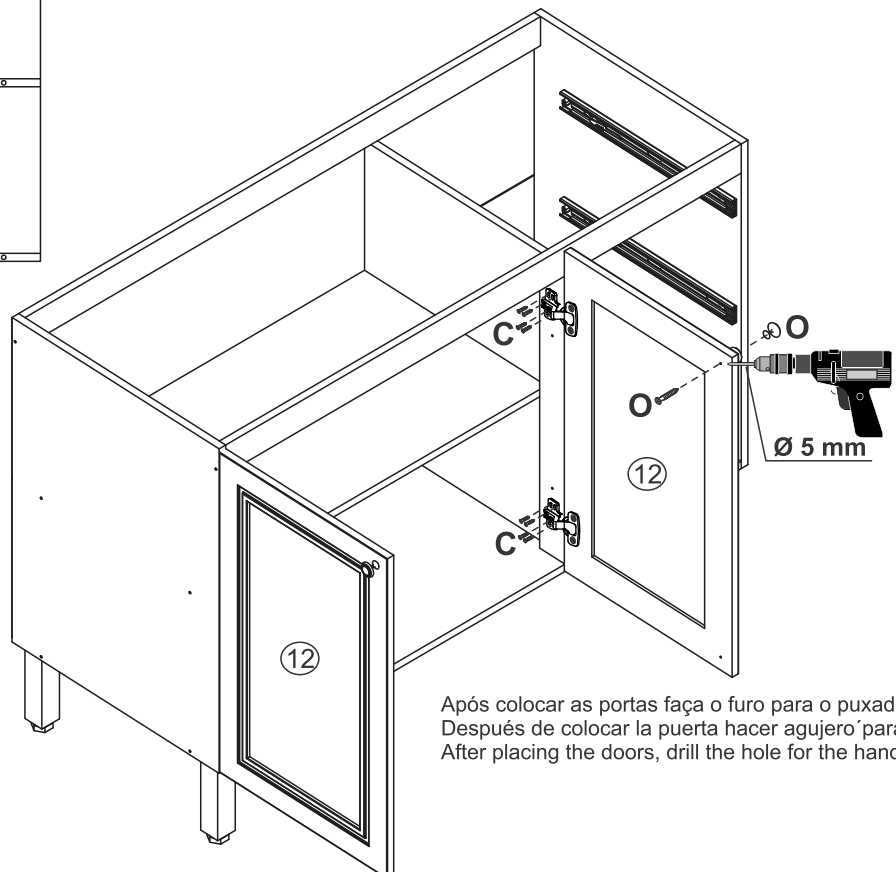
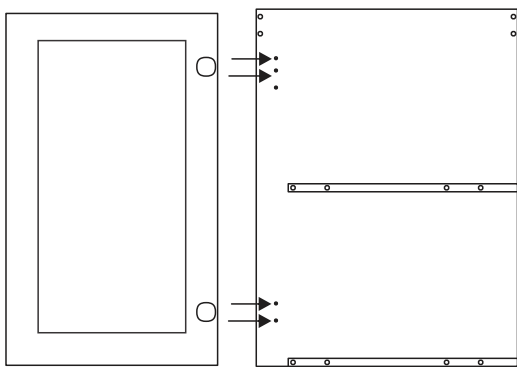

Após colocar as portas faça o furo para o puxador
Después de colocar la puerta hacer agujero para tornillo
After placing the doors, drill the hole for the handle



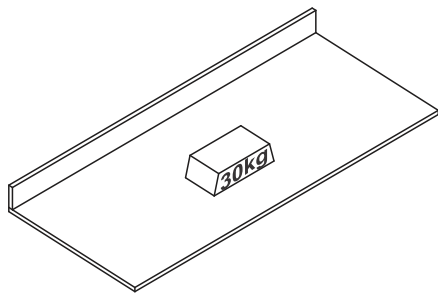

14

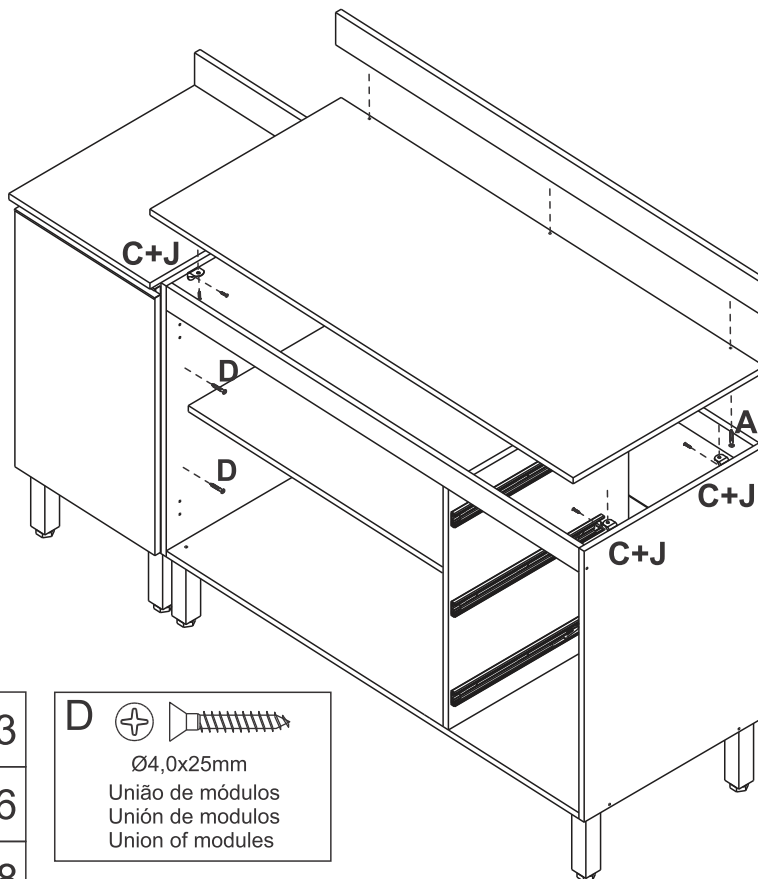



Tampo vendido separadamente
Top sold separately
La tapa se venden por separado



FERRAGENS/HERRAJES/HARDWARE

A	 	Ø4,0x40mm	03
C	 	Ø3,5x14mm	16
J			08

D	 	Ø4,0x25mm	
		União de módulos Unión de modulos Union of modules	

15

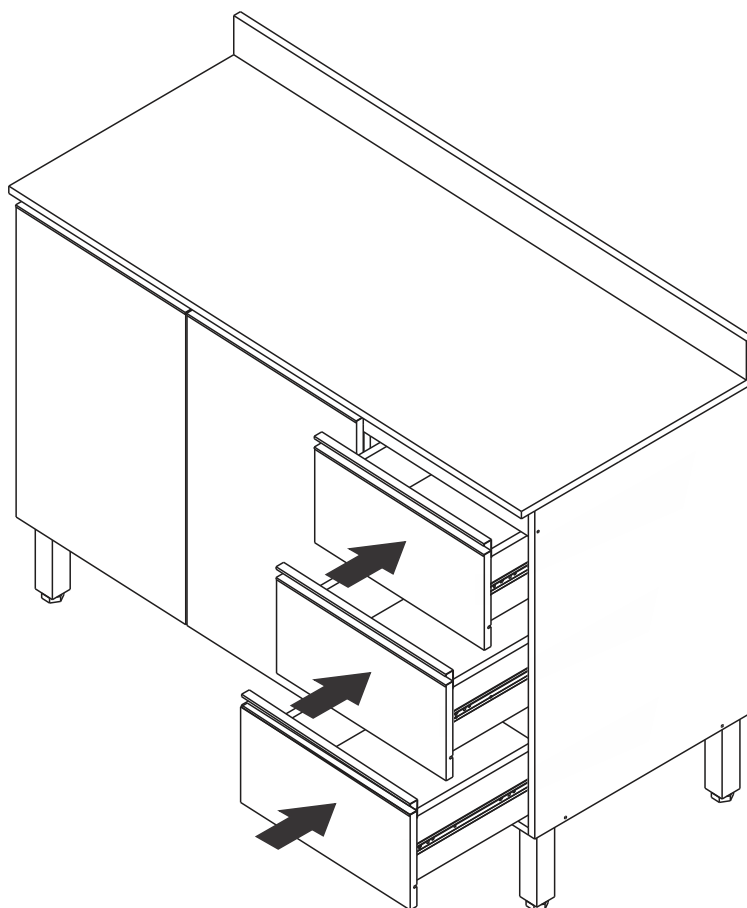

Quiditá

Essência da qualidade

Móveis Quiditá
Bento Gonçalves - RS
Rodovia BR-470 KM 202 - Cep 95710-000
Fone: 0xx (54) 3458-1001
www.quiditamoveis.com.br

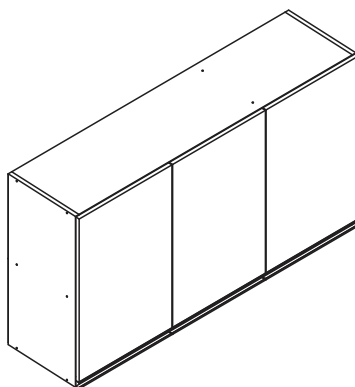



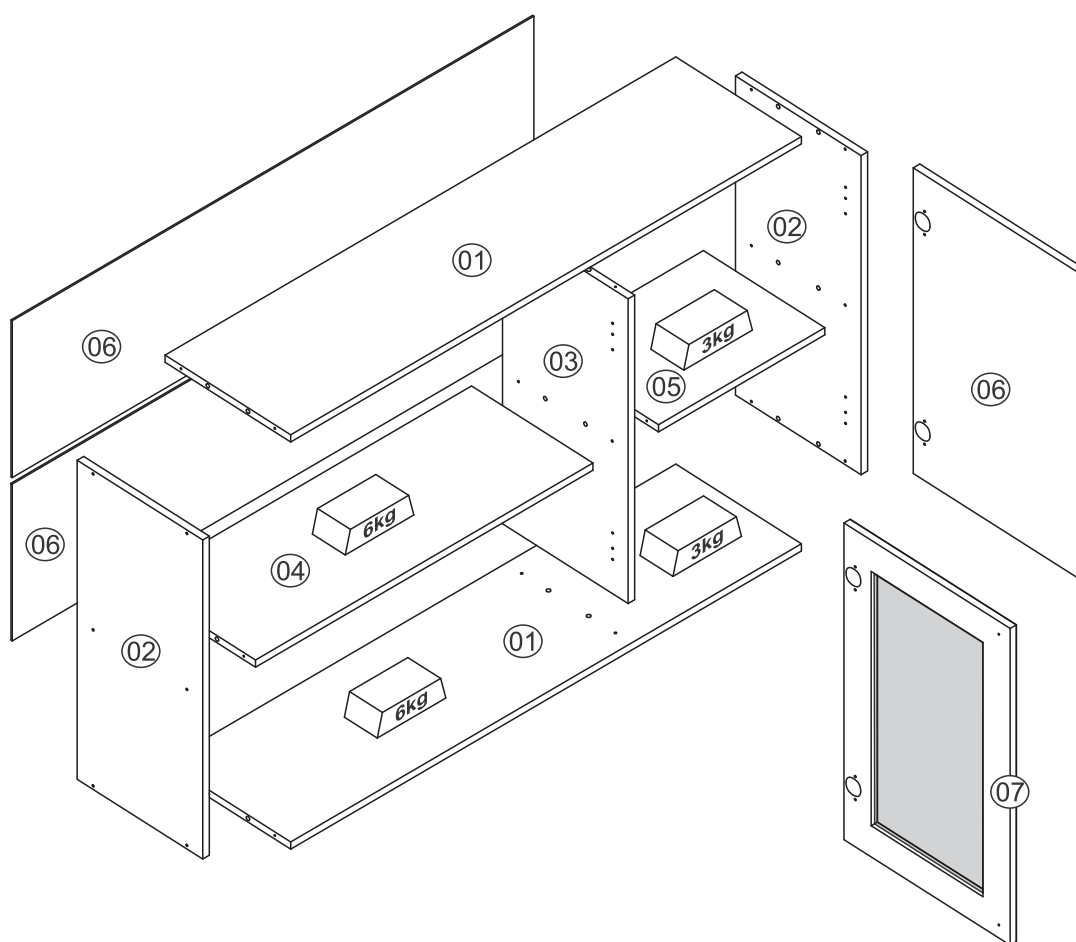



8030



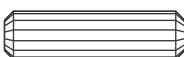
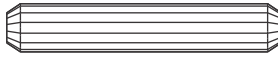

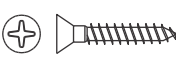
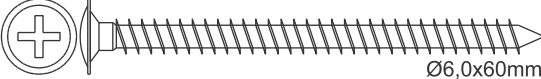
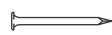

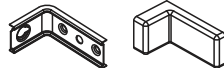
LISTA DE PEÇAS/RELACIÓN PIEZAS/PART LIST

Nº	Código Code	Descrição/Descripción/Description	Dimensão (mm) Dimensiones (mm) Measures (mm)	Qtde. Cantidad Quantity
01	803001	Base/Base/Base	1170 x 300 x 15	02
02	802502	Lateral/Side/Lateral	665 x 300 x 15	02
03	803002	Divisão/Division/División	635 x 300 x 15	01
04	803003	Prateleira maior/Repisa mayor/Large shelf	773 x 290 x 15	01
05	803004	Prateleira menor/Repisa menor/Small shelf	381 x 290 x 15	01
05	801010	Costa/Revés/Back	1195 x 327 x 03	02
06	800008	Porta/Puerta/Door (Ref. 8030)	637 x 397 x 15	03
07	Q01306	Porta/Puerta/Door (Ref. 8230)	660 x 397 x 15	03

FERRAGENS/HERRAJES/HARDWARE

A		Ø4,0x40mm	18
B		Cavilha/Tarugo/Dowel Ø8x30mm	16
C		Cavilha/Tarugo/Dowel Ø8x50mm	02
D		Ø3,5x14mm	54
E		Ø3,0x25mm	02
F		Ø6,0x60mm	04
G		Prego/Clavo/Nail 10x10	33
H		Bucha/Cojinete/Bush 8mm	04
I			04
J		Garra metálica/Pieza fijación revés/ Back claw 13x13	07

K		Sache cola/Pegamento/Glue	01
L		Dobradiça/Bisagra/Hinge 35mm	06
M		Tapa furo/Tapa agujero/Hole sticker 12mm	16
N		Puxador perfil/Tirador/Handle 397mm Ref. 8030	03
O		Puxador/Tirador/Handle Ref. 8230	03

FERRAMENTAS NECESSÁRIAS

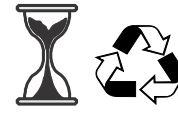
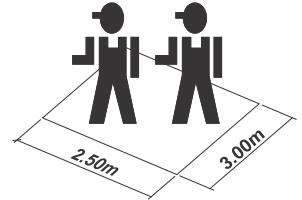
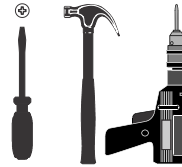

60 min

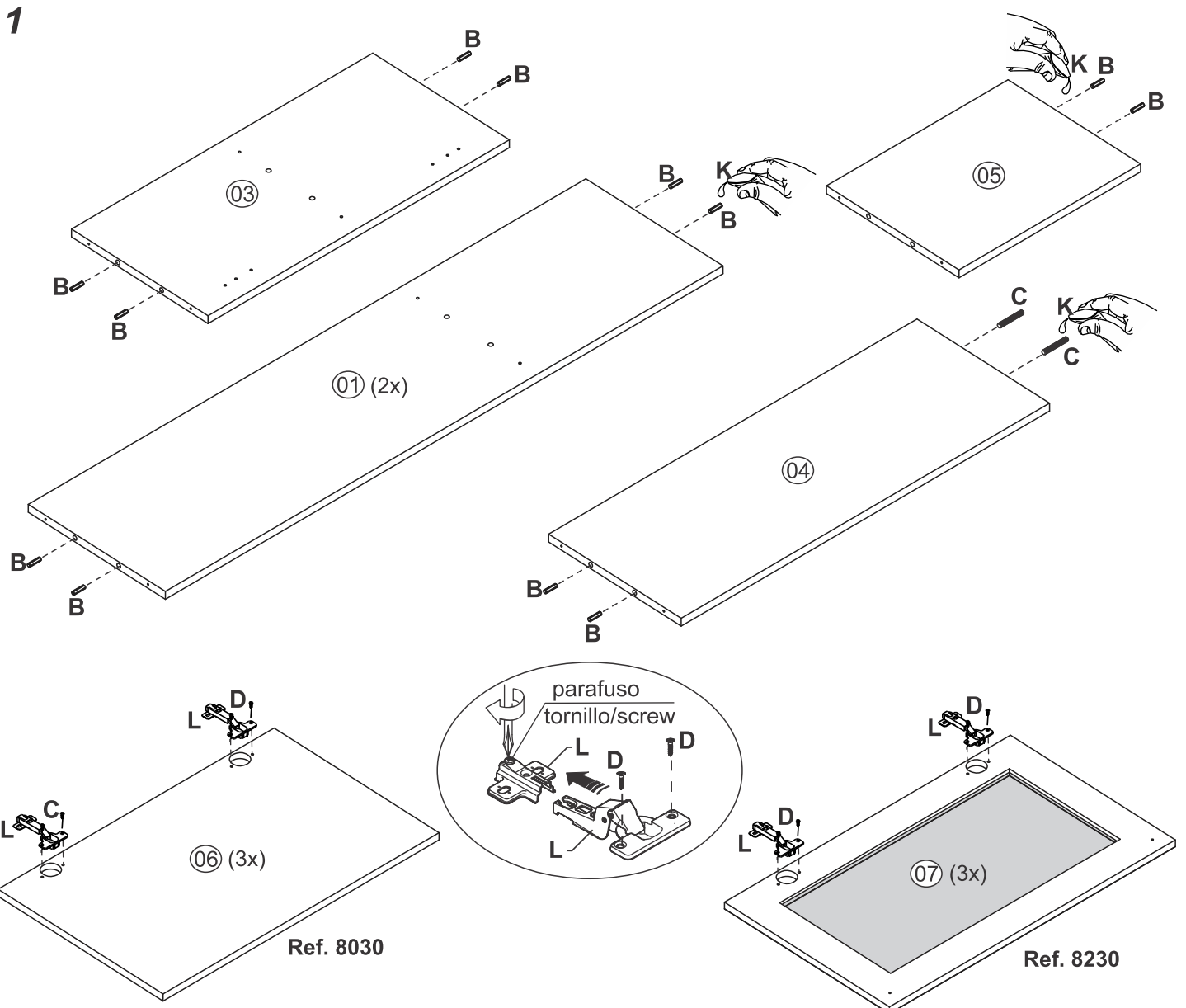

2

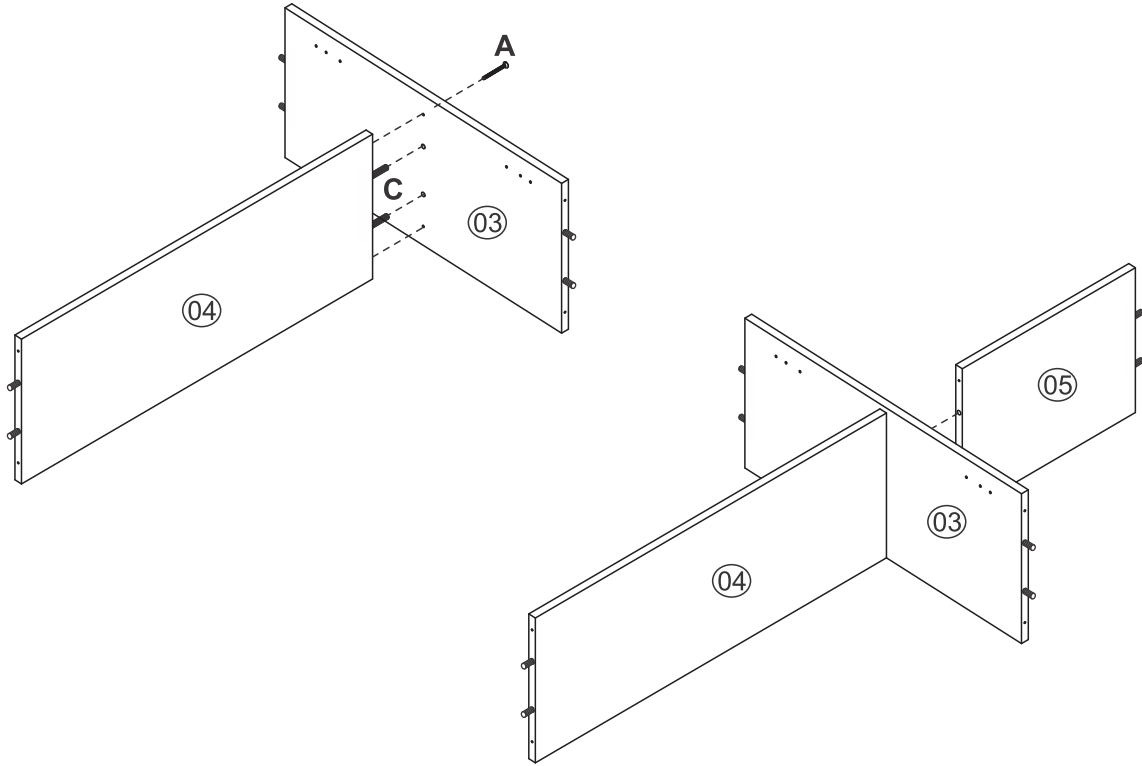

3

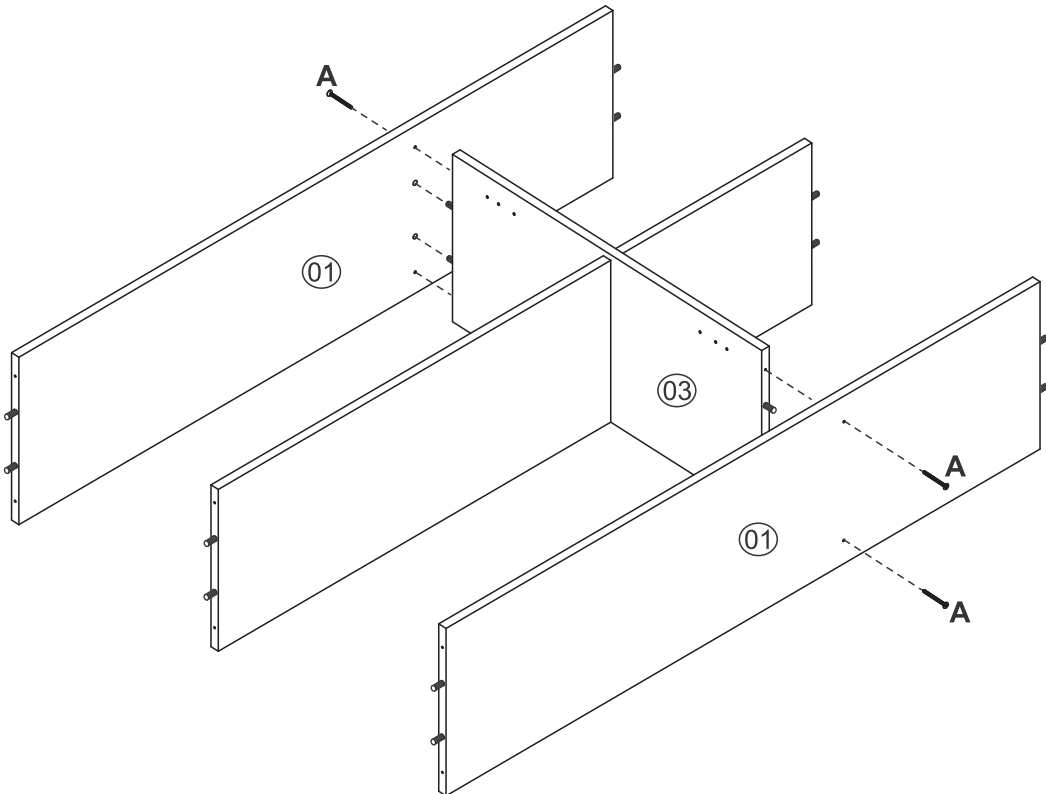

4

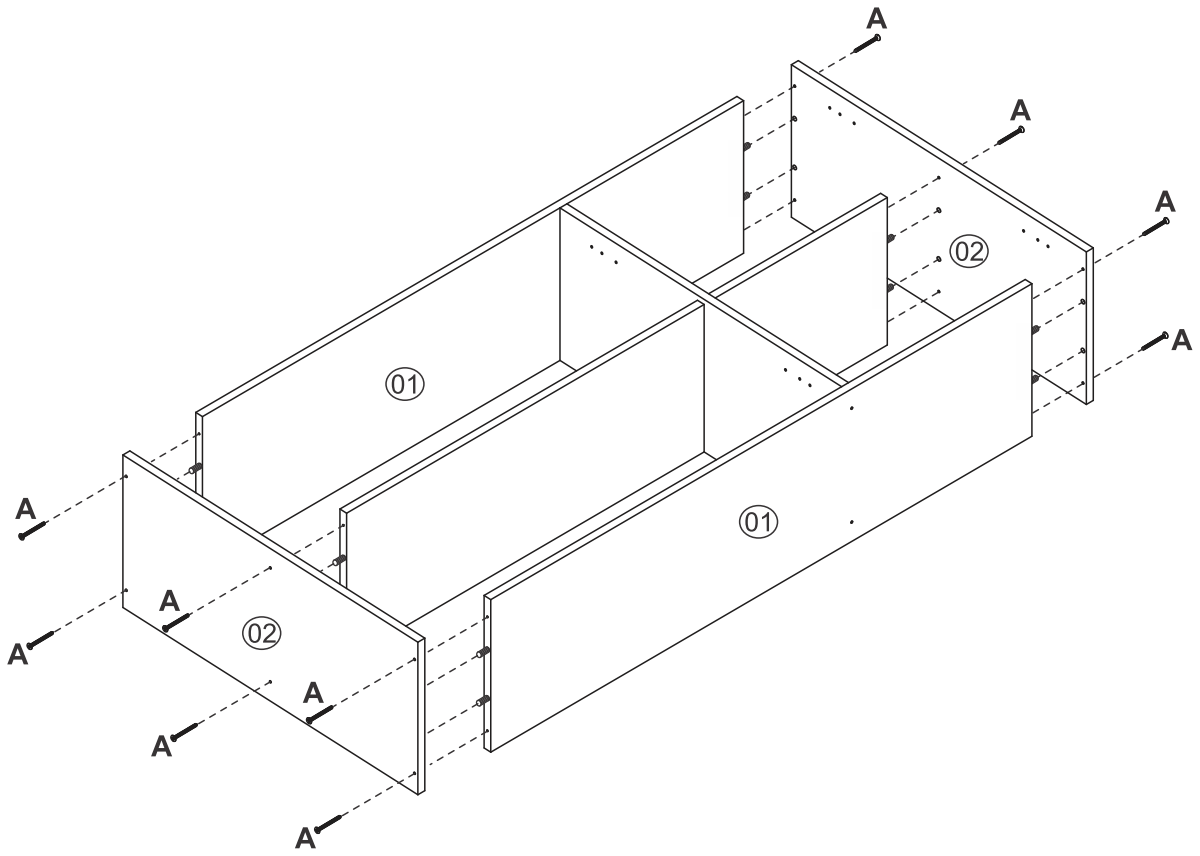

5

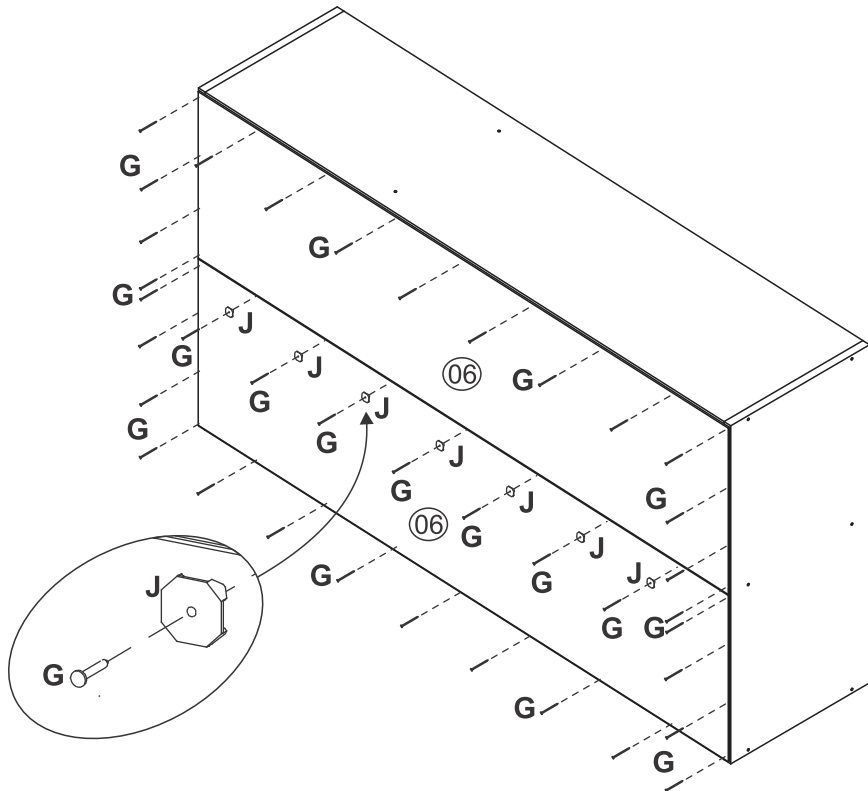

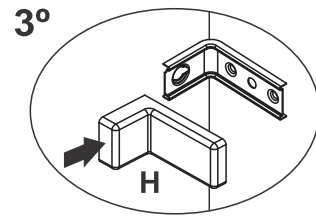
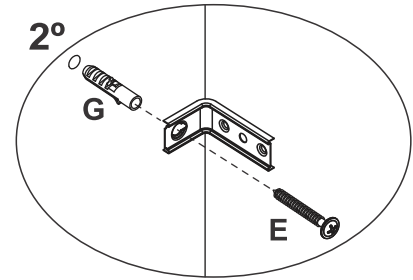
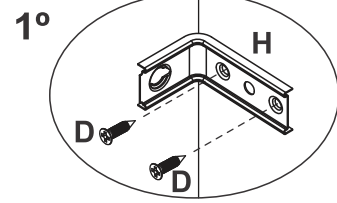
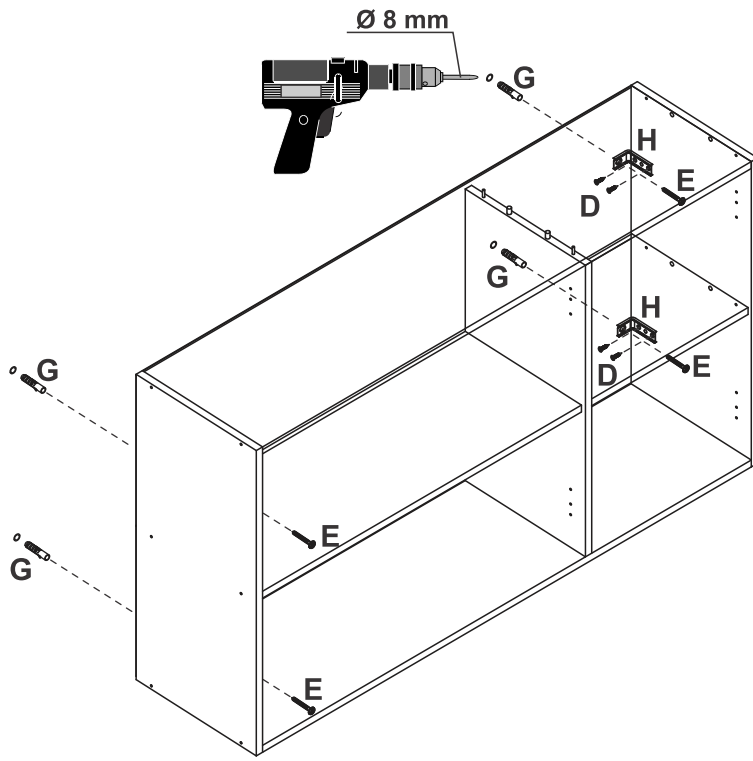

6

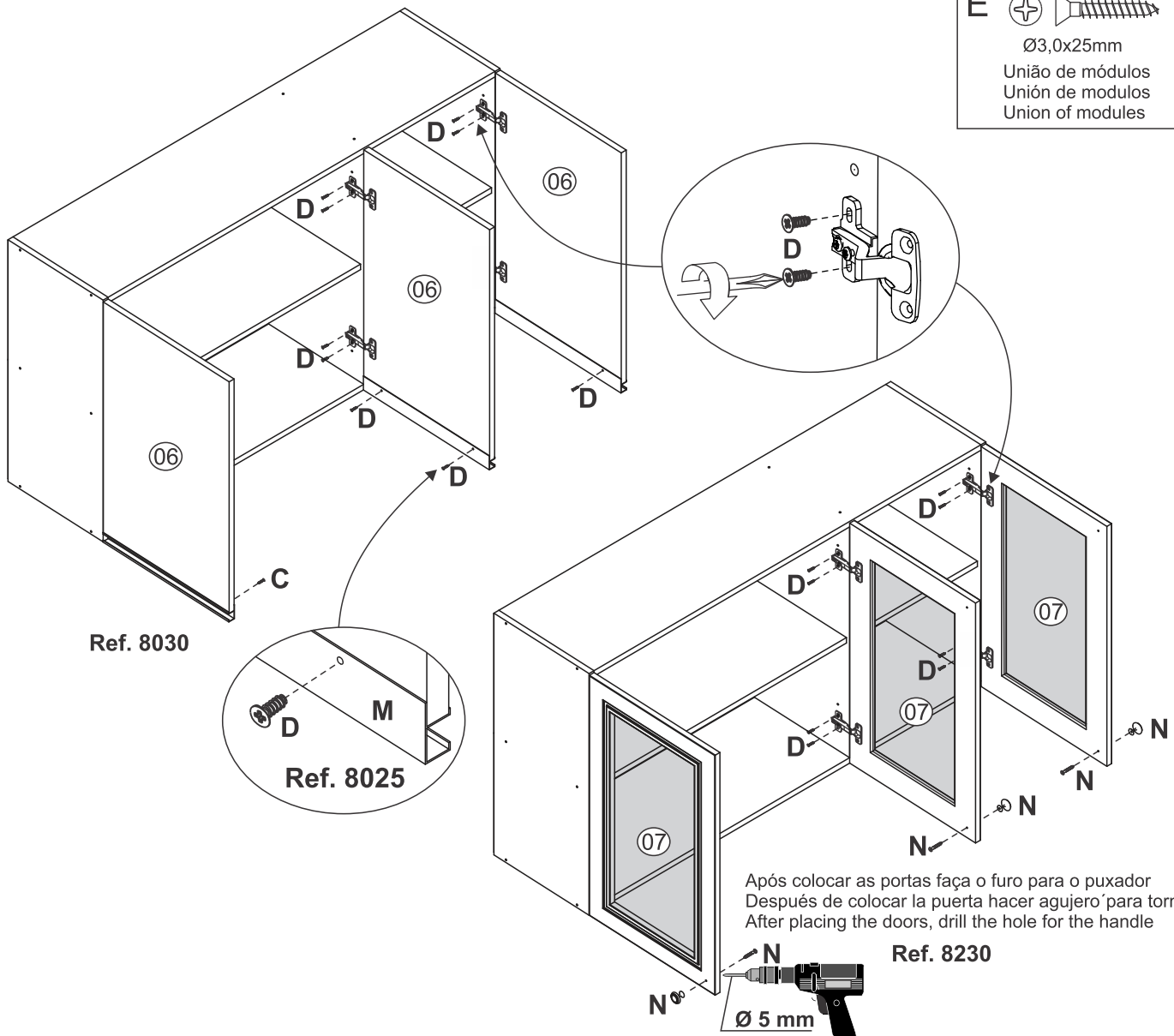

7



E  
 Ø3,0x25mm
 União de módulos
 Unión de módulos
 Union of modules

Ref. 8030

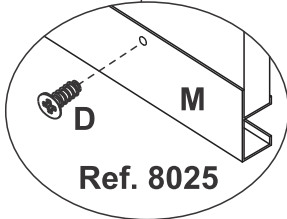

Ref. 8025

Após colocar as portas faça o furo para o puxador
 Después de colocar la puerta hacer agujero para tornillo
 After placing the doors, drill the hole for the handle

Ref. 8230

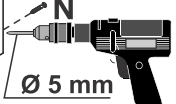

N
 Ø 5 mm

Quiditá

Essência da qualidade

Móveis Quiditá
Bento Gonçalves - RS
Rodovia BR-470 KM 202 - Cep 95710-000
Fone: 0xx (54) 3458-1001
www.quiditamoveis.com.br

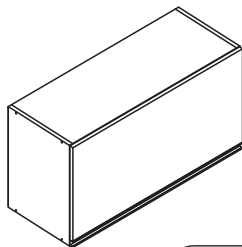

8040

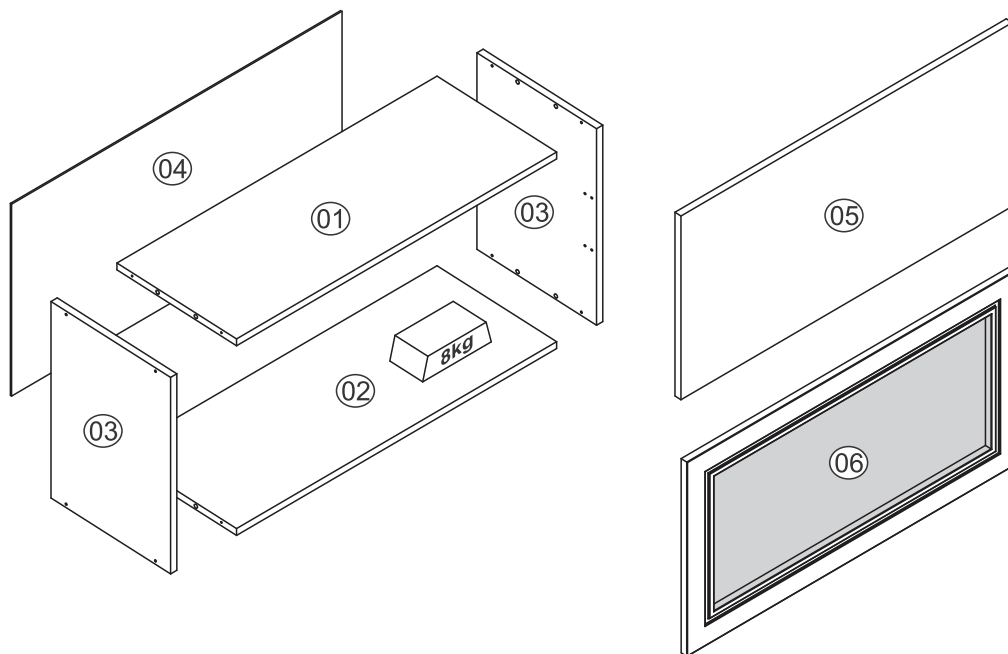

LISTA DE PEÇAS/RELACIÓN PIEZAS/PART LIST

8035

8235

Nº	Código Code	Descrição/Descripción/Description	Dimensão (mm) Dimensiones (mm) Measures (mm)	Qtde. Cantidad Quantity
01	803501	Tampo/Tapa/Top	770 x 300 x 15	01
02	802501	Base/Base/Base	770 x 300 x 15	01
03	803503	Lateral/Side/Lateral	332 x 300 x 15	02
04	800504	Costa/Revés/Back	795 x 327 x 03	01
05	803505	Porta/Puerta/Door (Ref. 8035)	797 x 305 x 15	01
06	Q01310	Porta/Puerta/Door (Ref. 8235)	797 x 328 x 15	01











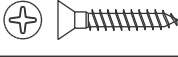
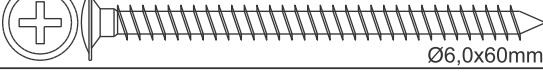

LISTA DE PEÇAS/RELACIÓN PIEZAS/PART LIST

8040

8240

Nº	Código Code	Descrição/Descripción/Description	Dimensão (mm) Dimensiones (mm) Measures (mm)	Qtde. Cantidad Quantity
01	803501	Tampo/Tapa/Top	770 x 300 x 15	01
02	802501	Base/Base/Base	770 x 300 x 15	01
03	804001	Lateral/Side/Lateral	430 x 300 x 15	02
04	804003	Costa/Revés/Back	795 x 420 x 03	01
05	804004	Porta/Puerta/Door (Ref. 8040)	797 x 402 x 15	01
06	Q01311	Porta/Puerta/Door (Ref. 8240)	797 x 425 x 15	01

FERRAGENS/HERRAJES/HARDWARE

A		08
B		08
C		27
D		02
E		04
F		20
G		04
H		04
I		01
J		01
K		02
L		16
M		01
N		01

FERRAMENTAS NECESSÁRIAS

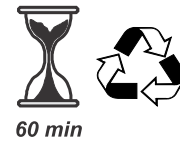
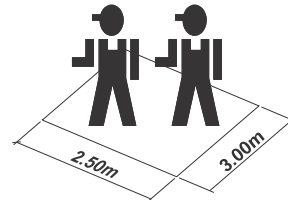
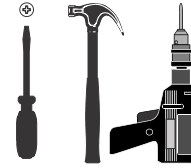

1

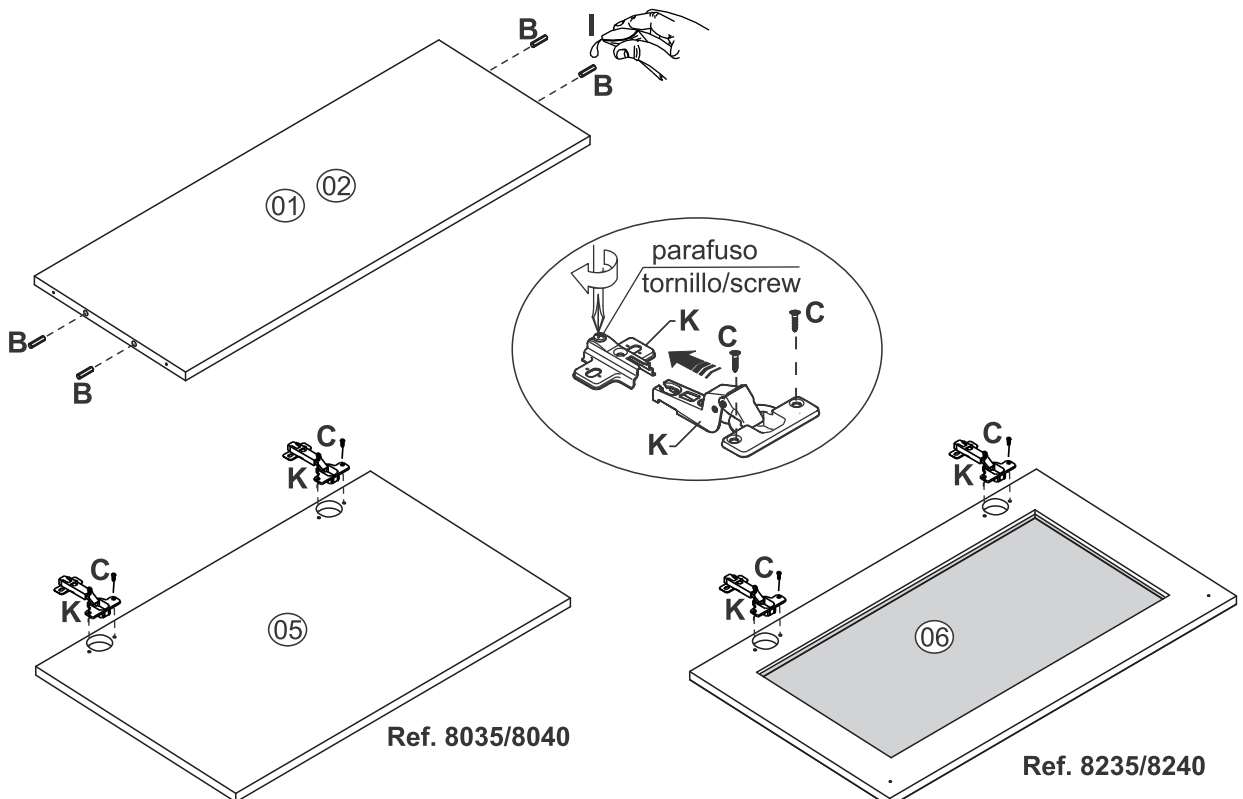

2

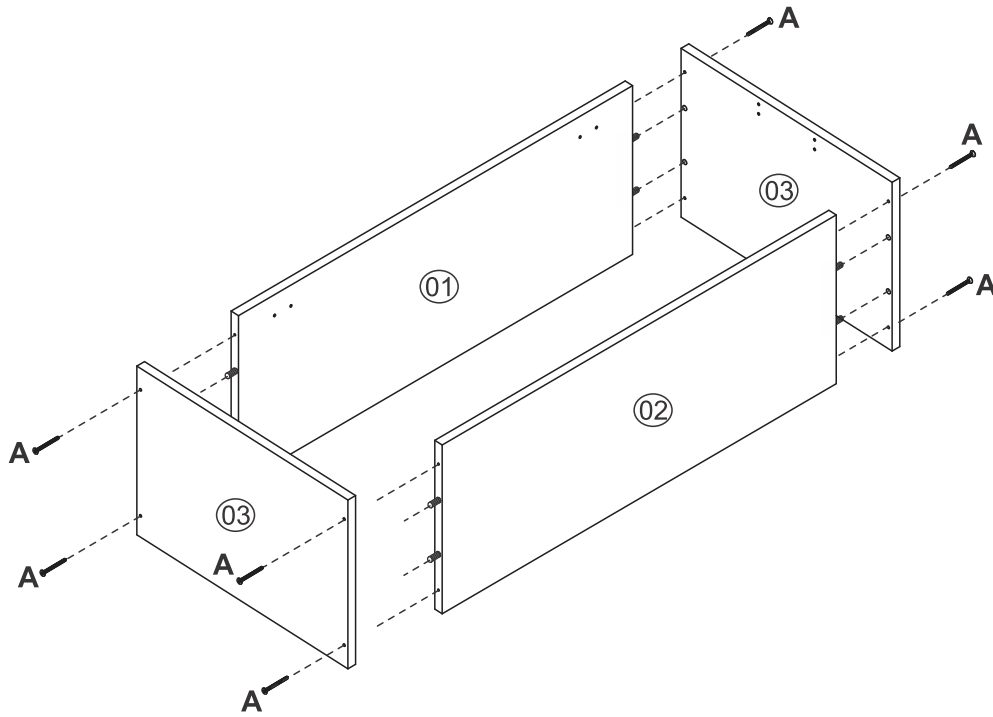

3

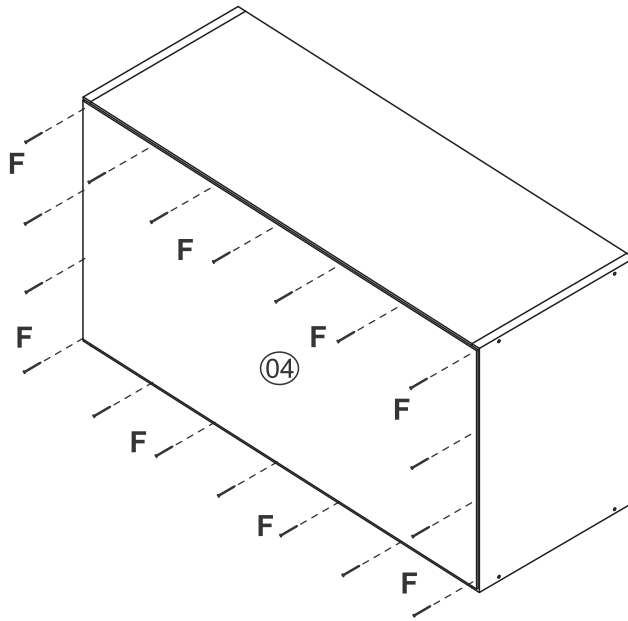

4

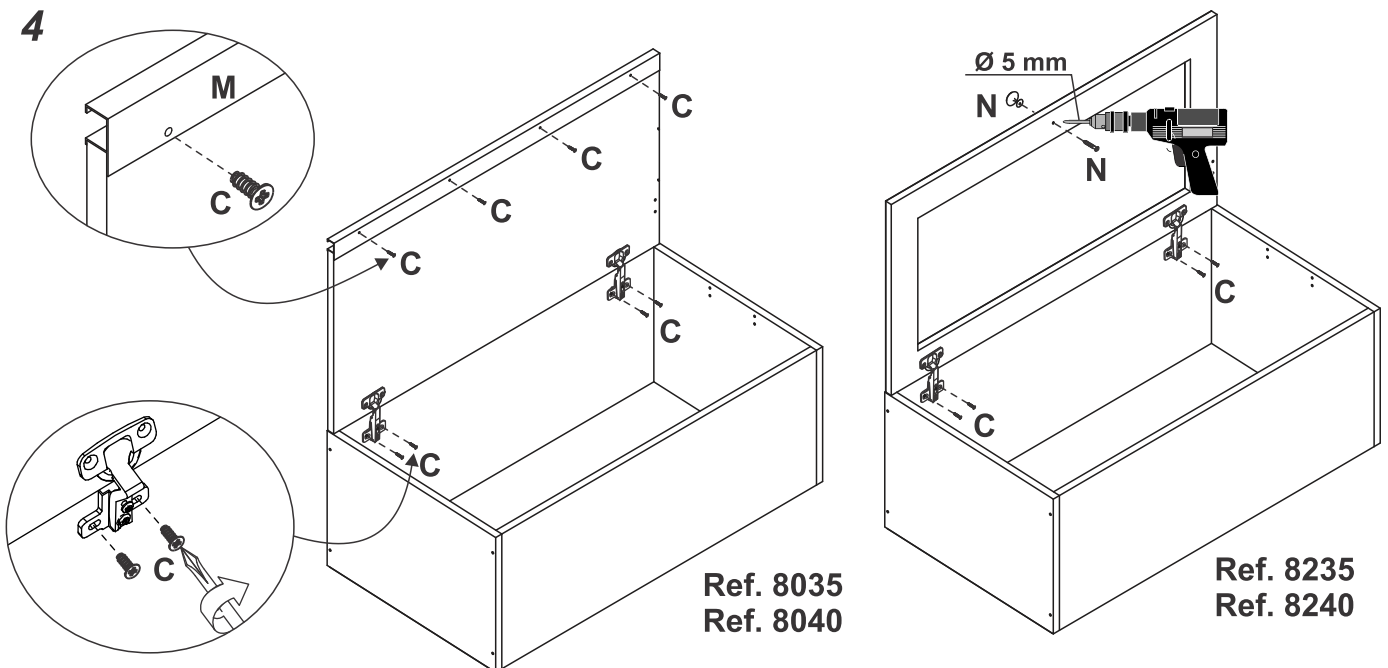

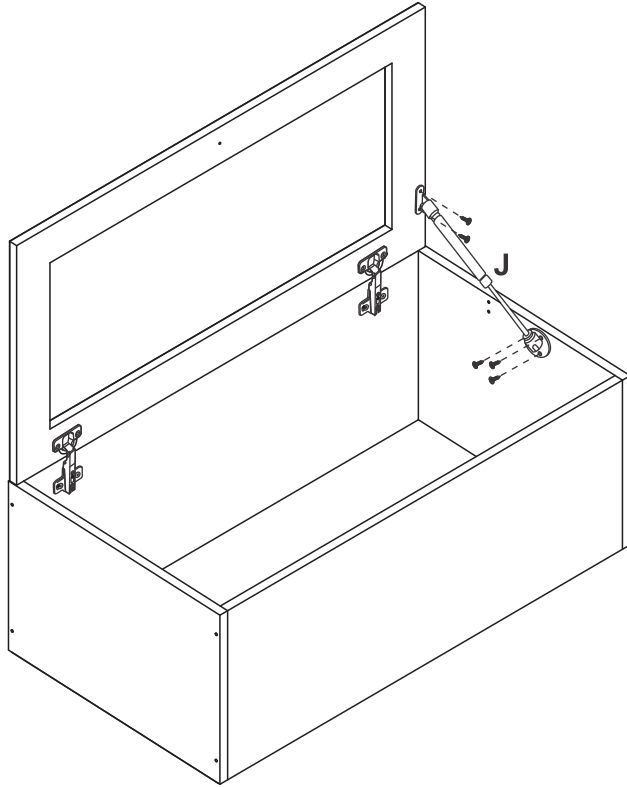

5

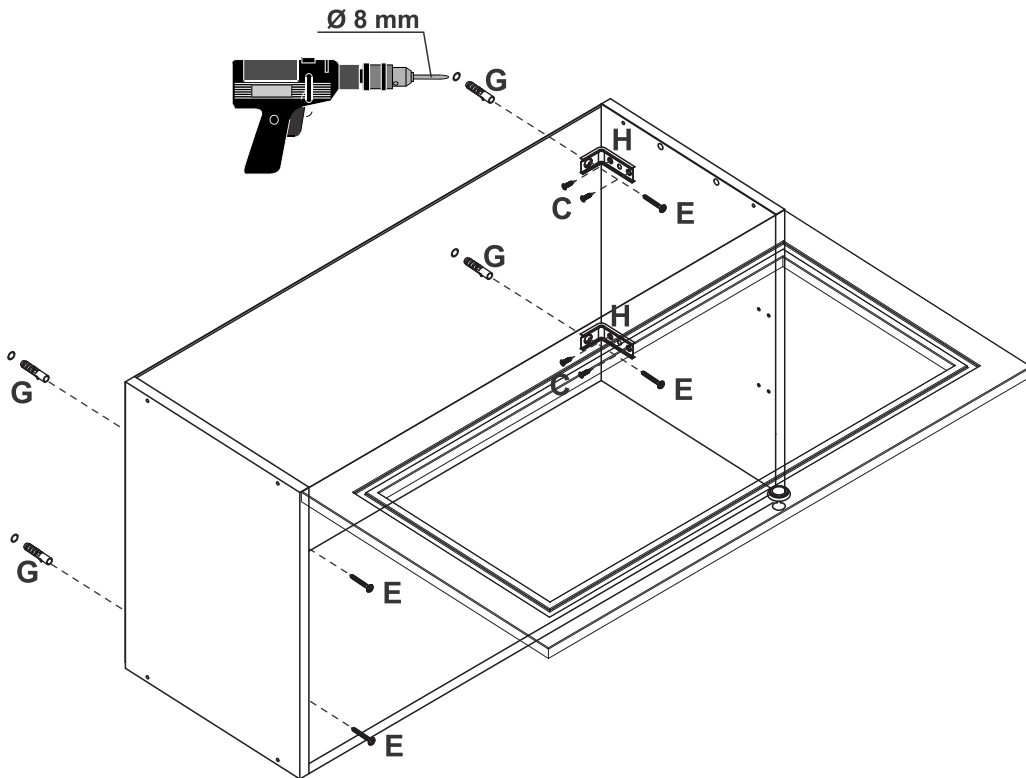

6



D  
Ø3,0x25mm
União de módulos
Unión de módulos
Union of modules

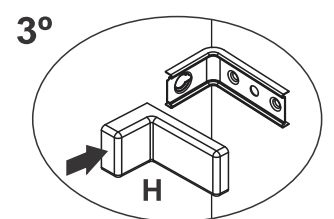
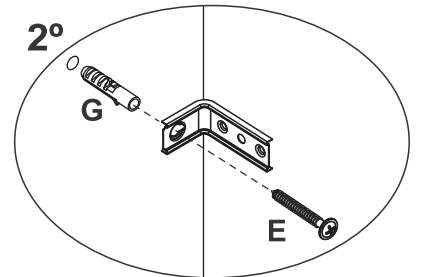
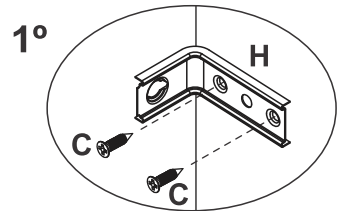

Quiditá

Essência da qualidade

Móveis Quiditá
Bento Gonçalves - RS
Rodovia BR-470 KM 202 - Cep 95710-000
Fone: 0xx (54) 3458-1001
www.quiditamoveis.com.br

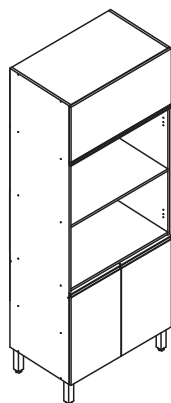

8060

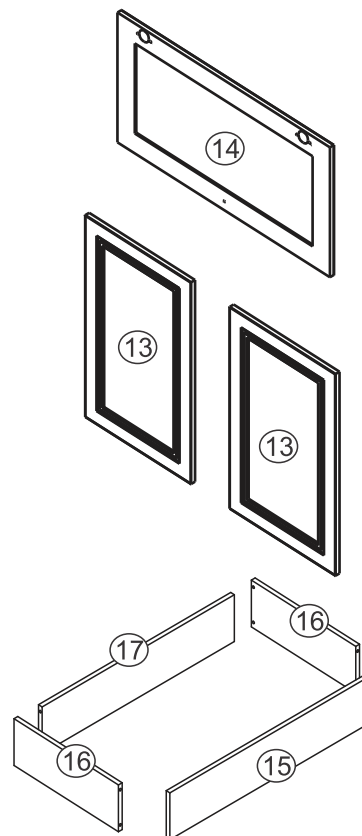
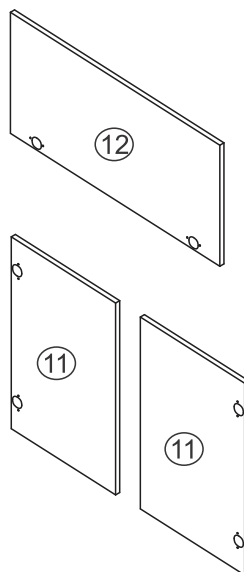
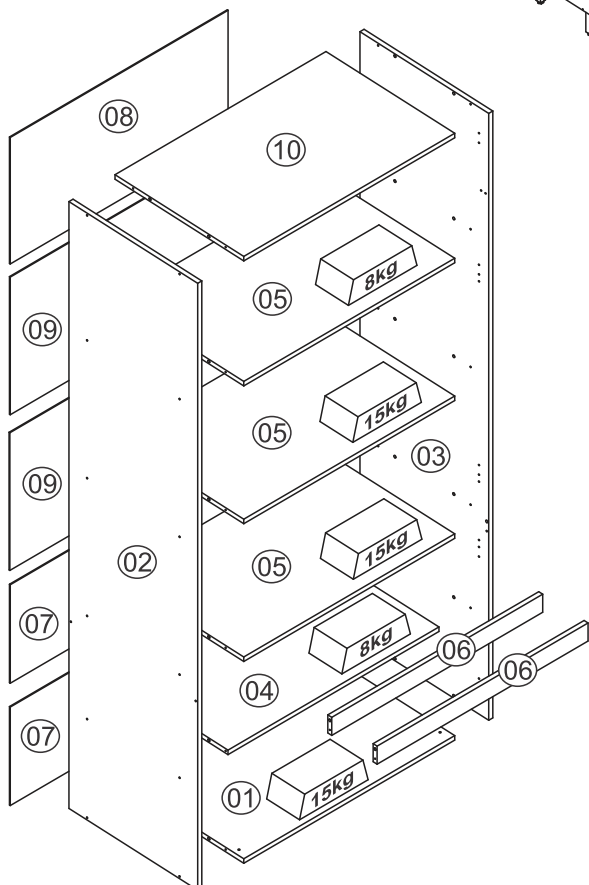

LISTA DE PEÇAS/RELACIÓN PIEZAS/PART LIST

Ref. 8060/8260

FERRAMENTAS NECESSÁRIAS
HERRAMIENTAS NECESARIAS
NECESSARY TOOLS/

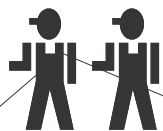
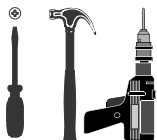









2,50m
3,00m

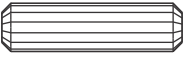

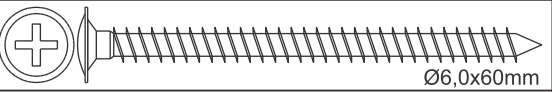

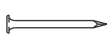
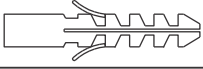
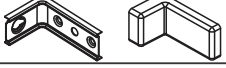



60 min

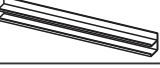

Nº	Código Code	Descrição/Descripción/Description	Dimensão (mm) Dimensiones (mm) Measures (mm)	Qtde. Cantidad Quantity
01	800501	Base/Base/Base	770 x 490 x 15	01
02	806004	Lateral esquerda/Left side/L teral izquierda	2015 x 490 x 15	01
03	806003	Lateral direita/Right side/Lateral derecha	2015 x 490 x 15	01
04	800502	Prateleira/Repisa/Shelf	770 x 430 x 15	01
05	806002	Prateleira/Repisa/Shelf	770 x 490 x 15	03
06	800503	Travessa/Traverse/Travessaño	770 x 60 x 15	02
07	800504	Costa/Revés/Back	795 x 327 x 3	02
08	804003	Costa/Revés/Back	795 x 420 x 3	01
09	806005	Costa/Revés/Back	795 x 457 x 3	02
10	806001	Tampo/Tapa/Top	770 x 490 x 15	01
11	800008	Porta/Puerta/Door (Ref. 8060)	637 x 397 x 15	02
12	804004	Porta/Puerta/Door (Ref. 8060)	797 x 402 x 15	01
13	Q01306	Porta/Puerta/Door (Ref. 8260)	660 x 397 x 15	02
14	Q01311	Porta/Puerta/Door (Ref. 8260)	797 x 425 x 15	01
Ref. 8260				
15	811001	Rodapé frontal/Front baseboard/Zócalo delantero	800 x 170 x 15	01
16	810501	Rodapé lateral/Side baseboard/Zócalo lateral	435 x 170 x 15	02
17	811002	Rodapé traseiro/Back baseboard/Zócalo de atras	768 x 170 x 15	01

FERRAGENS/HERRAJES/HARDWARE

A		Ø4,0x40mm	28
B		Cavilha/Tarugo/Dowel Ø8x30mm	28
C		Ø3,5x14mm	79
D		Ø3,5x25mm	04
E		Ø6,0x60mm	04
F		Ø5,0x50mm Ref. 8060	04
G		Prego/Clavo/Nail 10x10	60
H		Bucha/Cojinete/Bush 8mm	04
I			04
J		Garra metálica/Pieza fijación revés/ Back claw 13x13	15
K		Sache cola/Pegamento/Glue	01
L		Dobradiça/Bisagra Hinge 35mm	10

M		Tapa furo/Tapa agujero/Hole sticker 12mm	28
N		Puxador perfil/Tirador/Handle 397mm Ref. 8060	02
O		Puxador/Tirador/Handle Ref. 8260	03
Q			04
R		Puxador perfil/Tirador/Handle 797mm Ref. 8060	01
S			01

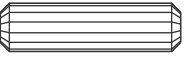
ROD400 - 8260

B		Cavilha/Tarugo/Dowel Ø8x30mm	08
C		Ø3,5x14mm	32
P			16

1

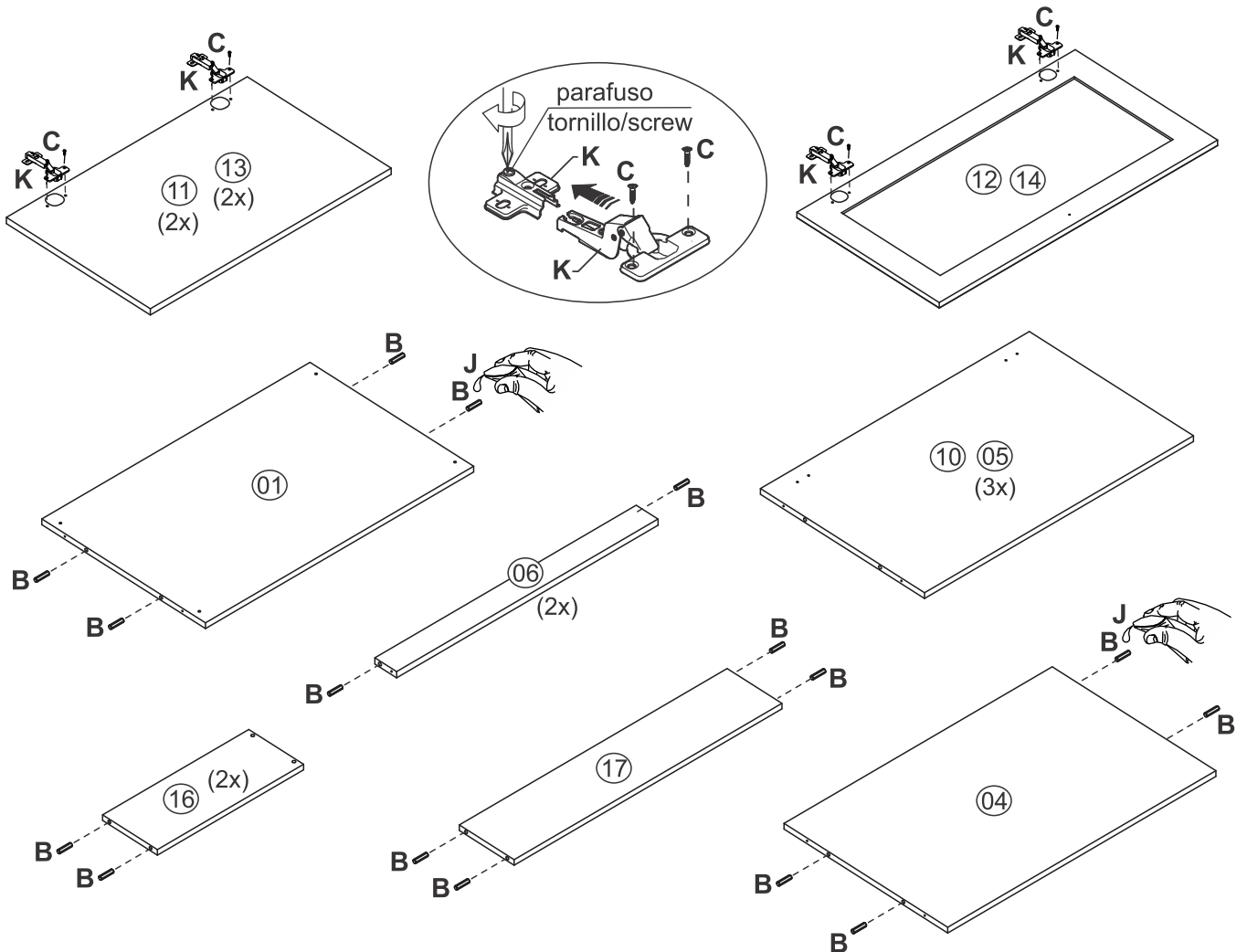

2 Ref. 8060/8260

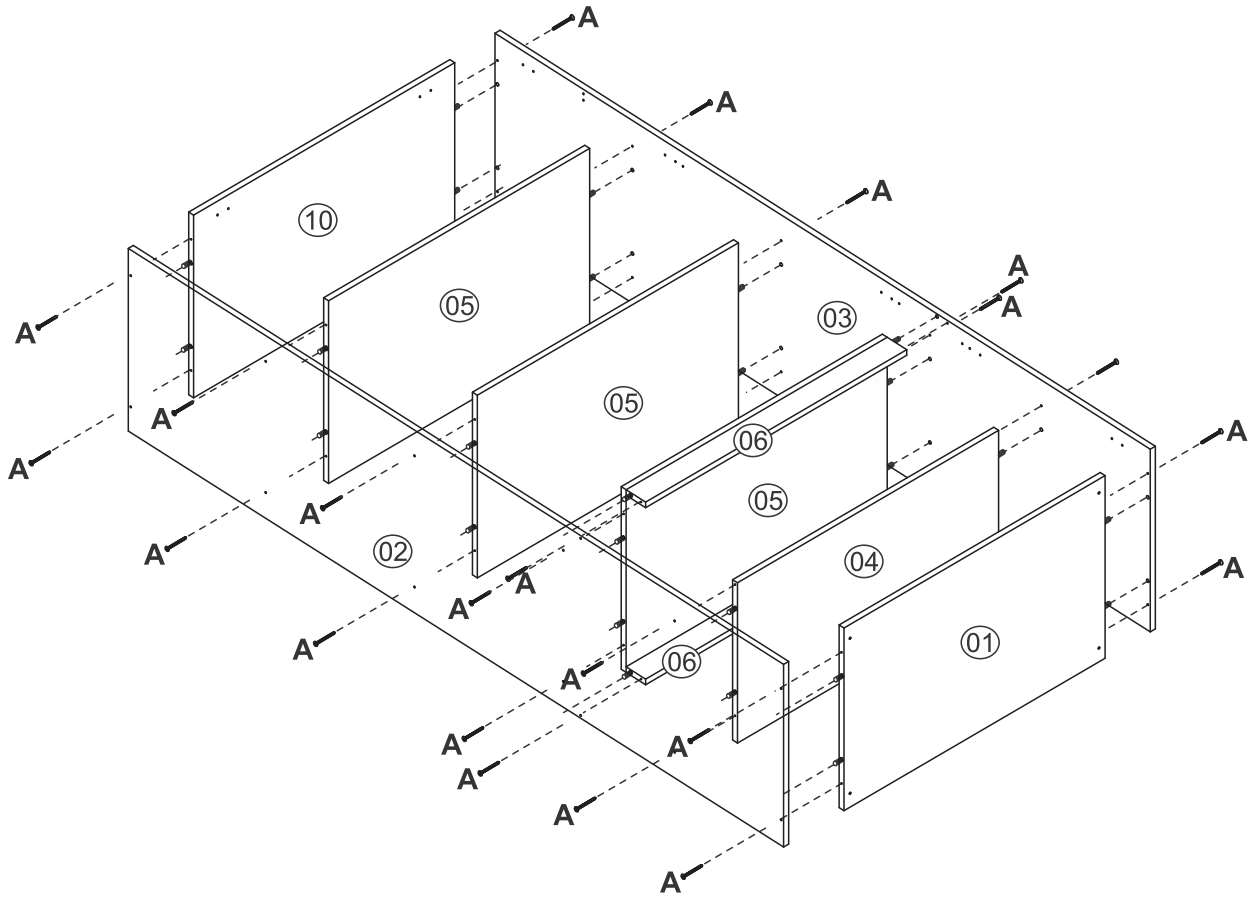

3

Ref. 8060

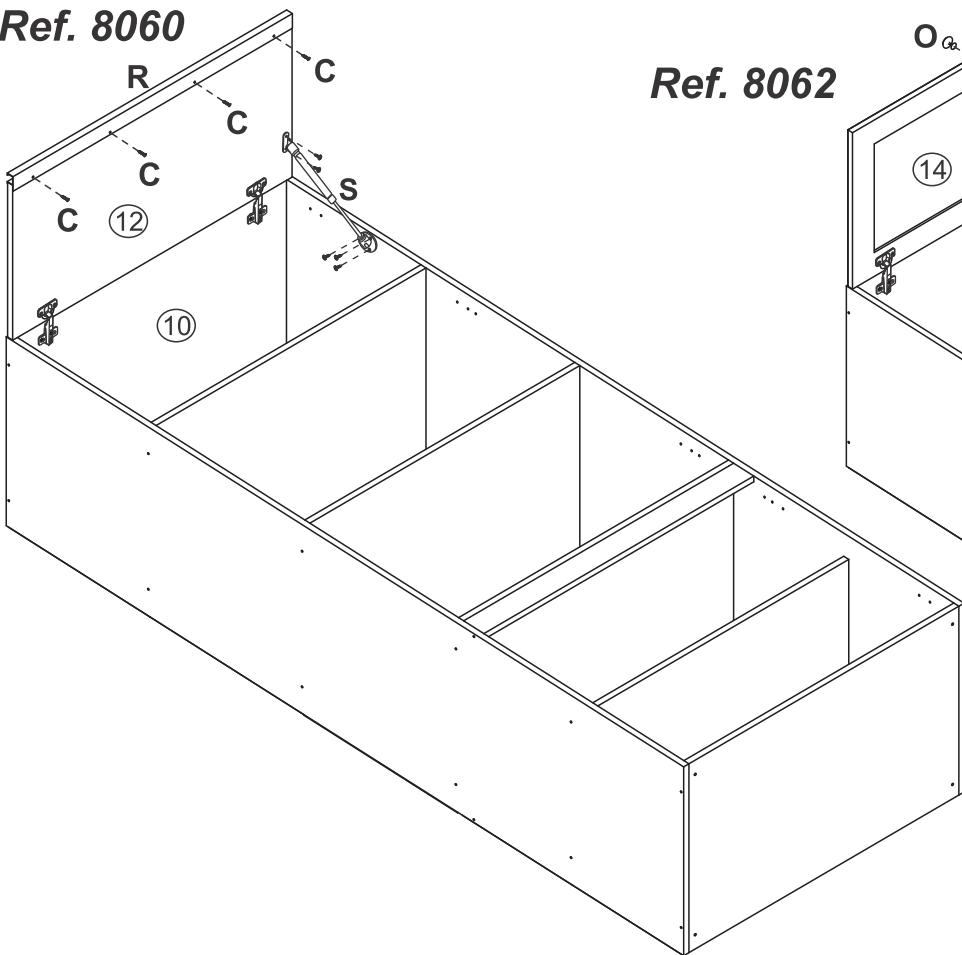

Ref. 8062

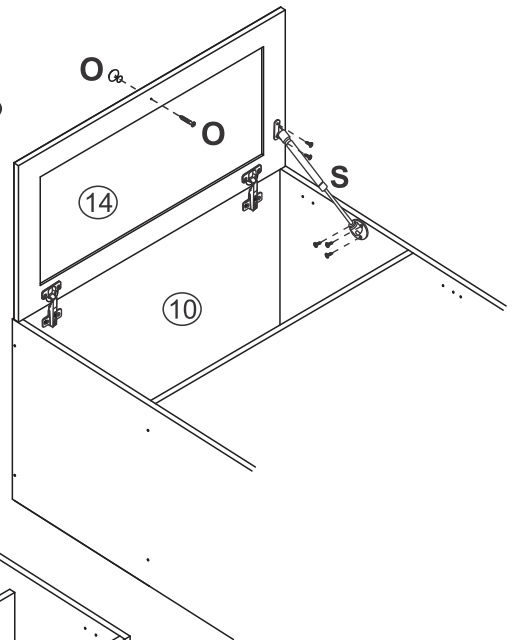

4 - Ref. 8060

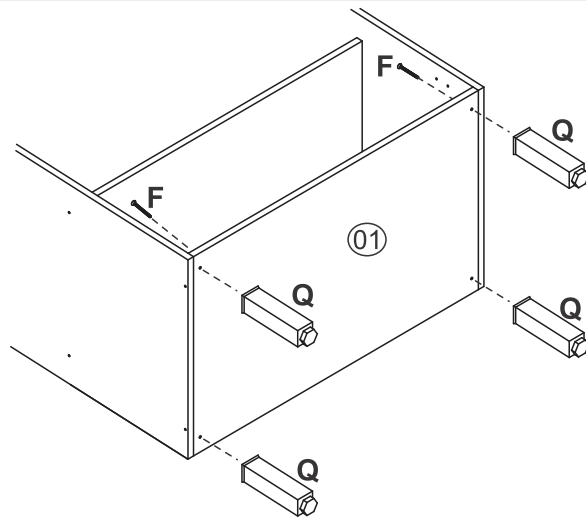

4 - Ref. 8260

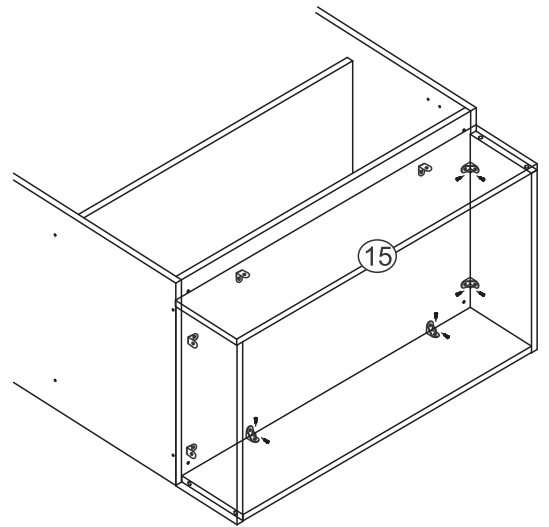
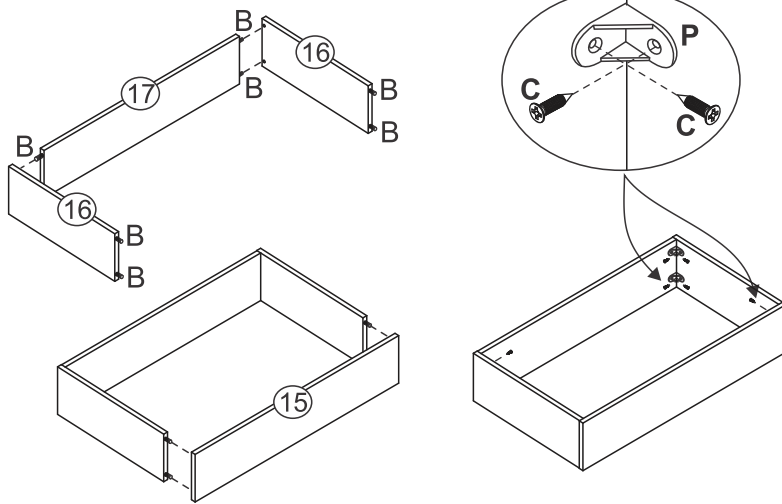

5

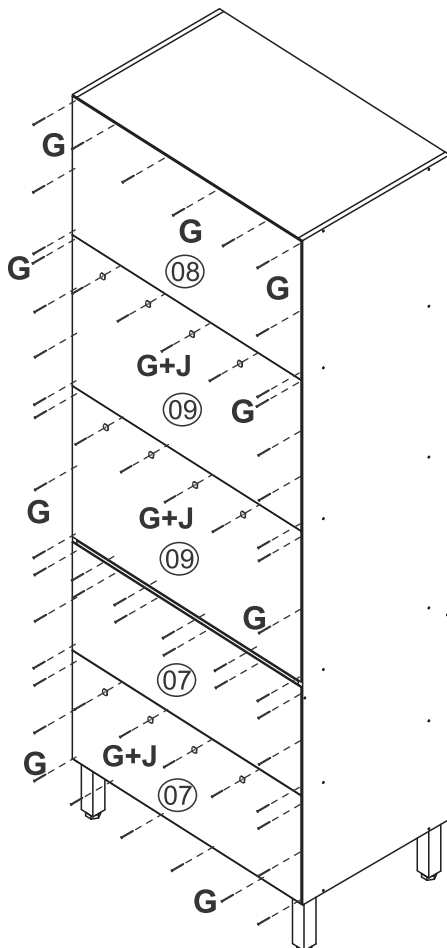

Se usar forno eletrico não
fixar estas costas
Si usa un horno eléctrico,
no fijar estos respaldos
If using an electric oven,
do not fix these backs

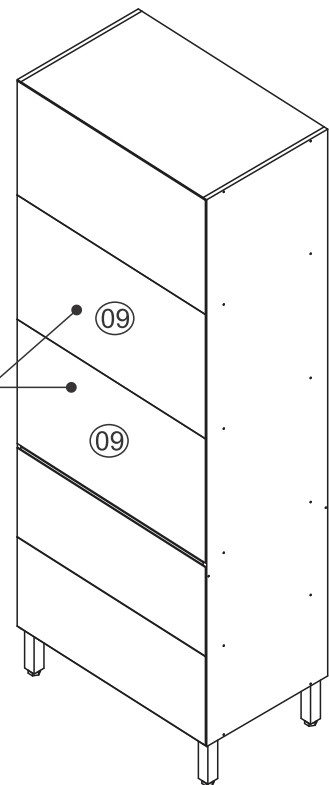

6 Fixação na parede / Fixing in the wall / Fijación en pared - opcional

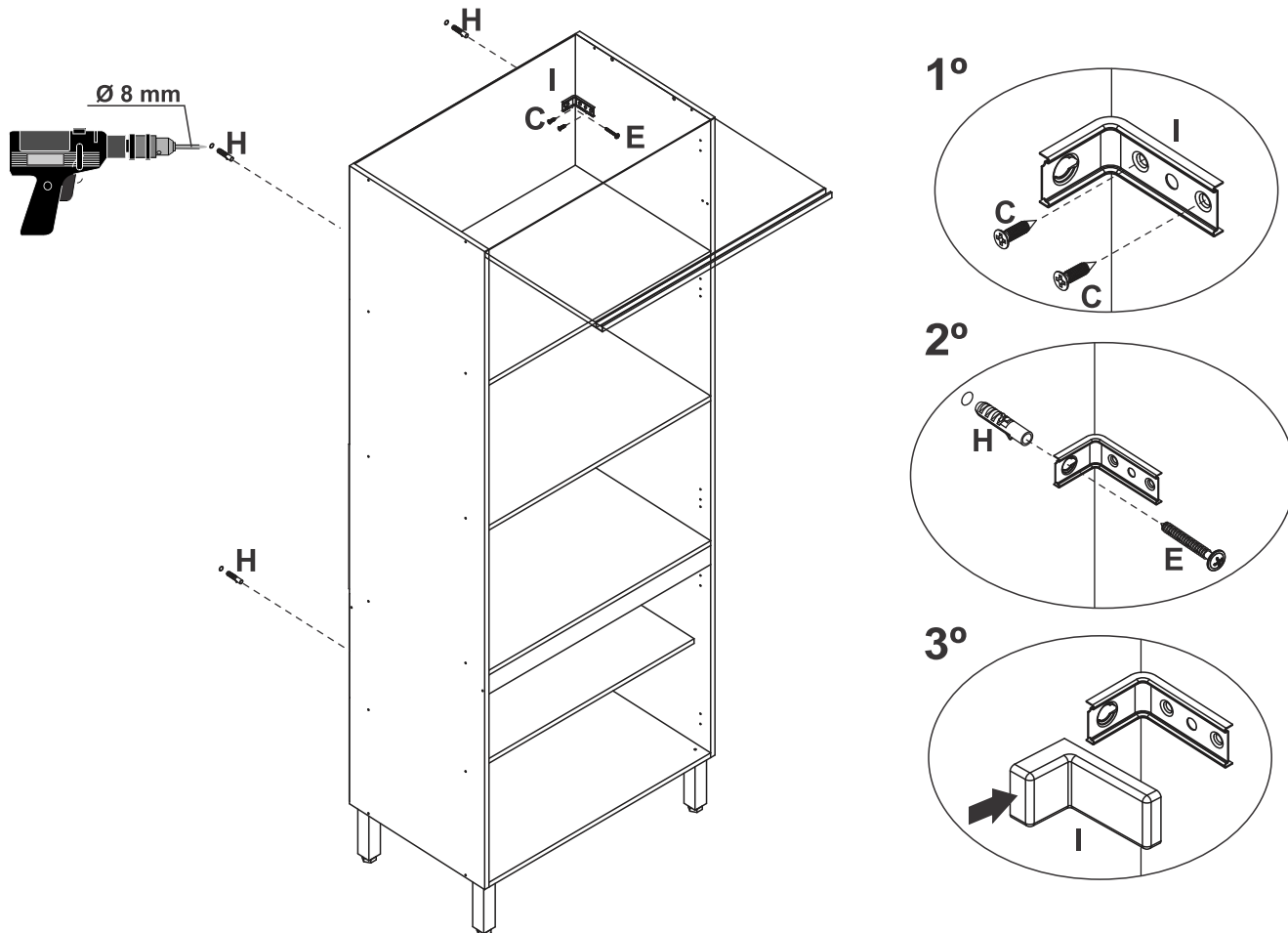

7

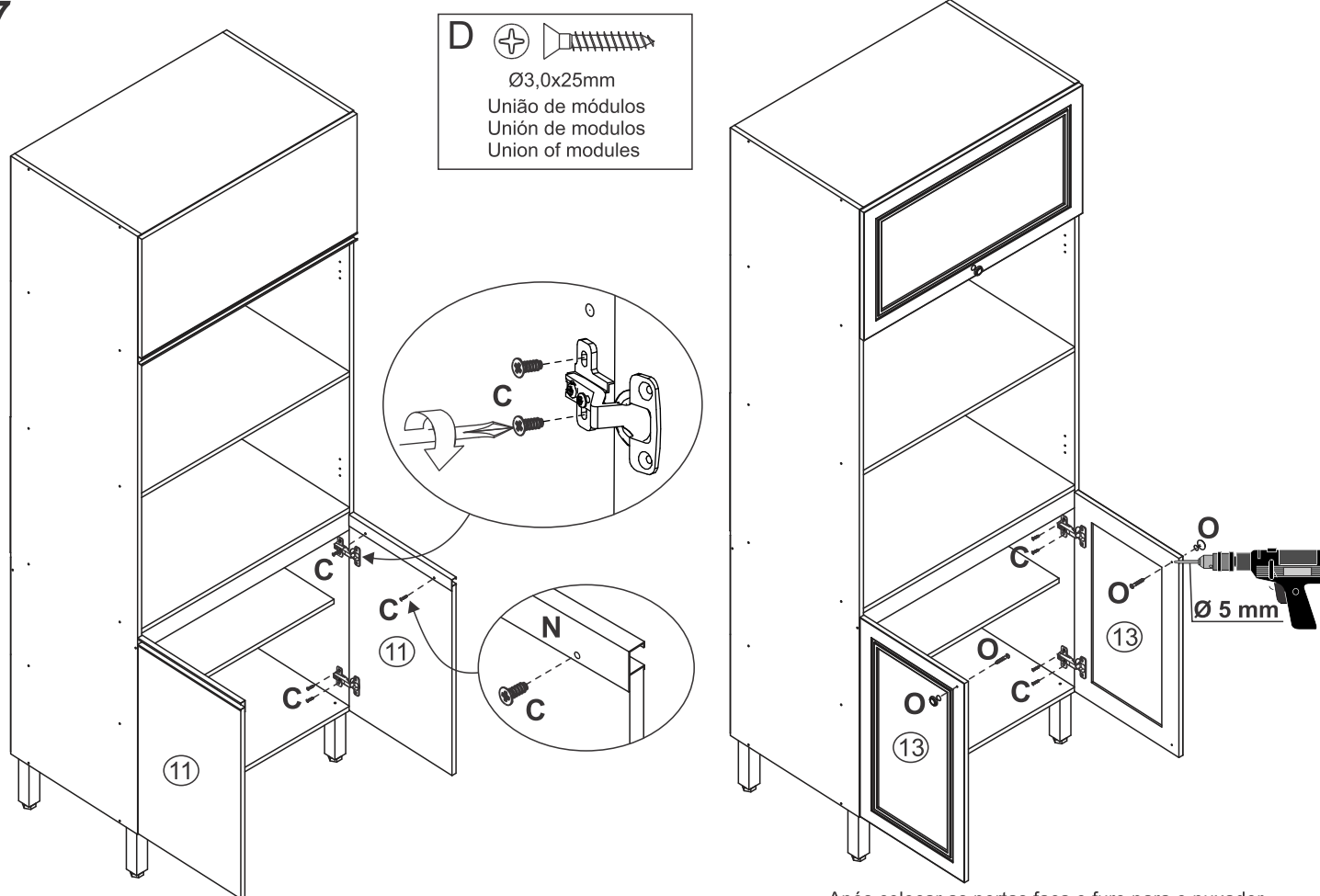

Após colocar as portas faça o furo para o puxador
 Después de colocar la puerta hacer agujero para tornillo
 After placing the doors, drill the hole for the handle