

PANELEIRO IARA

REF.: 667

MANUAL DE MONTAGEM / ASSEMBLY MANUAL / MANUAL DE MONTAJE

Centralizar o puxador
Center the handle
Centrar el mango

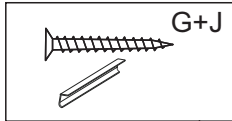

FERRAGENS / HARDWARE / EQUIPOS

A		Parafuso 4 x 40 Screw 4 x 40 Tornillo 4x40
B		Prego 10 x 10 Nail 10 x 10 Clavo 10 x 10
D		PÉS FEET PIES
F		Bucha Bushing Cojinete
G		Puxador Handle Manejar
I		Dobradiça Hinge Bisagra
J		Parafuso 3,5 x 14 Screw 3,5 x 14 Tornillo 3,5x14
K		Suporte Support Apoyo
M		Parafuso 5 X 50 Screw 5 x 50 Tornillo 5 x50
L		Suporte Parede Wall Support Soporte de pared

Para o puxador não se movimentar
pode ser utilizado cola instantânea para melhorar a fixação
entre a fita de borda e o puxador.

To prevent the handle from moving
instant glue can be used to improve fixation
between the edge band
and the handle.

Para evitar que el mango se mueva
Se puede utilizar pegamento instantáneo para mejorar la fijación.
entre el borde y el mango.

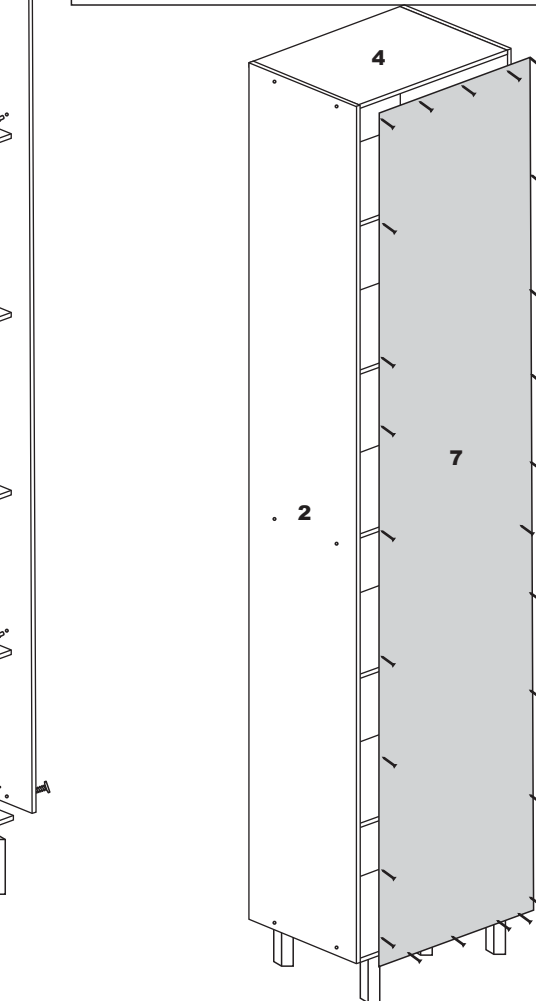
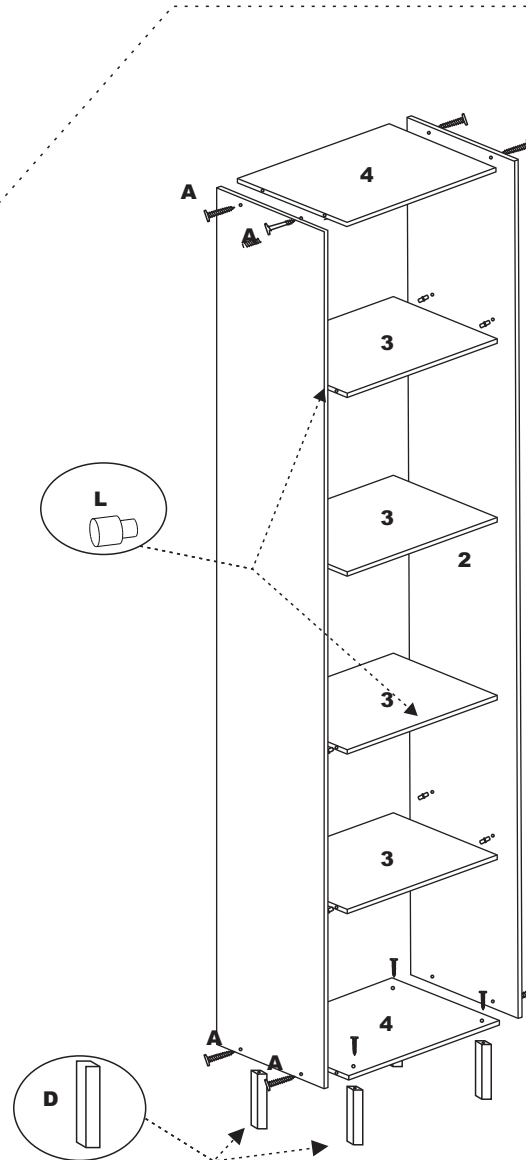
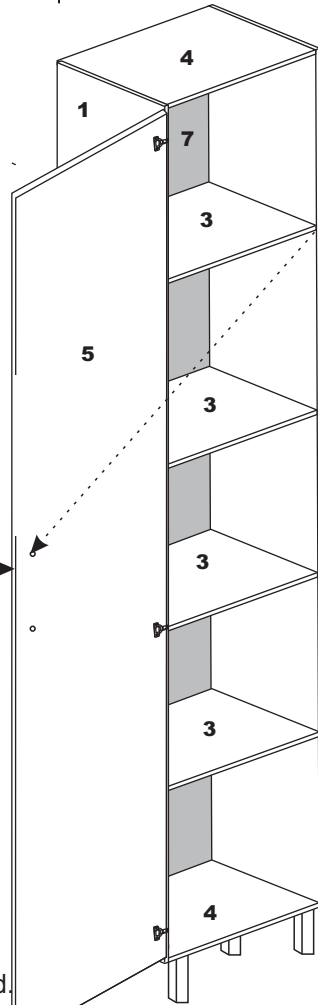
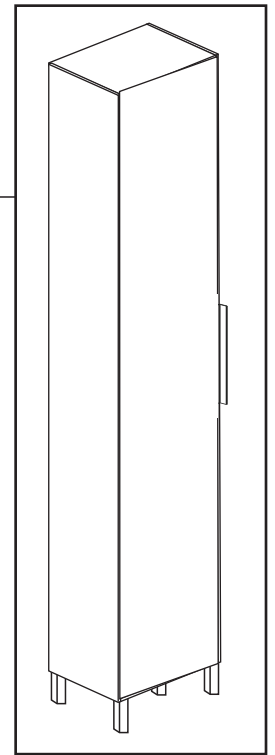

If you require any type of assistance
technique, have this assembly diagram at hand.

Si requieres algún tipo de asistencia
técnica, tenga a mano este esquema de montaje.

Em caso de solicitação de algum tipo de assistência
técnica, tenha este esquema de montagem em mãos.

BALCÃO DE PIA IARA

REF.: 649

MANUAL DE MONTAGEM ASSEMBLY INSTRUCTIONS INSTRUCCIONES DE MONTAJE

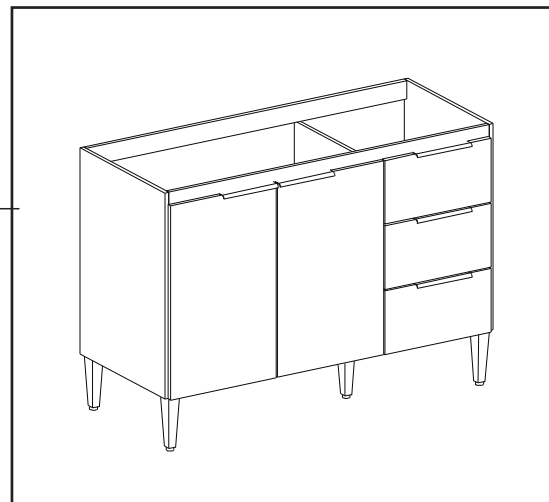

1º PASSO
1º STEP
1º PASO

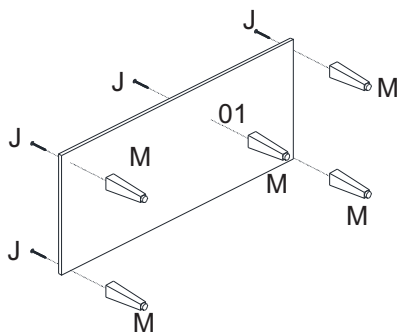

2º PASSO
2º STEP
2º PASO

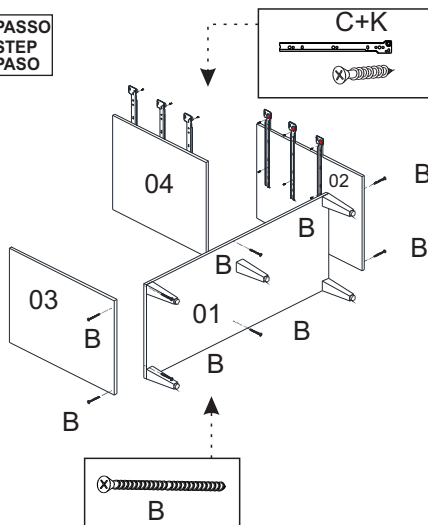

3º PASSO
3º STEP
3º PASO

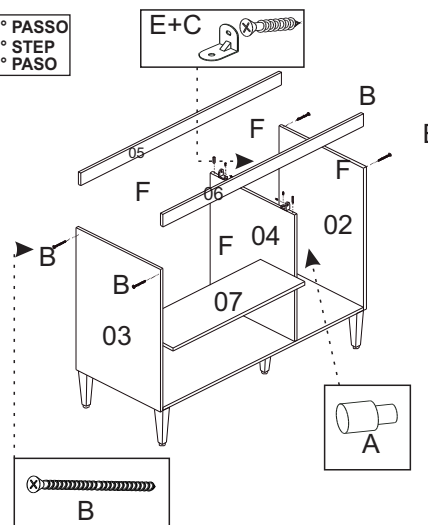

4º PASSO
4º STEP
4º PASO

3X

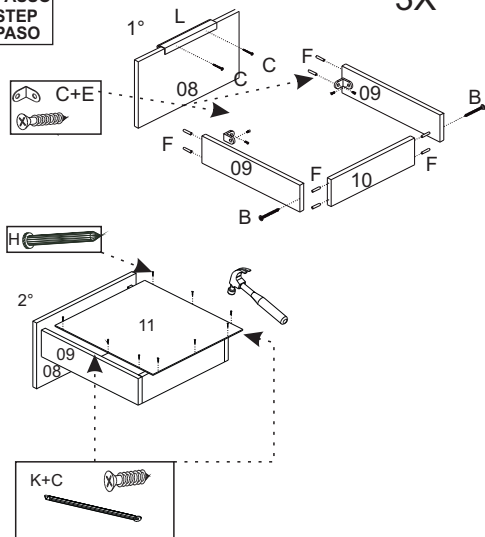

5º PASSO
5º STEP
5º PASO

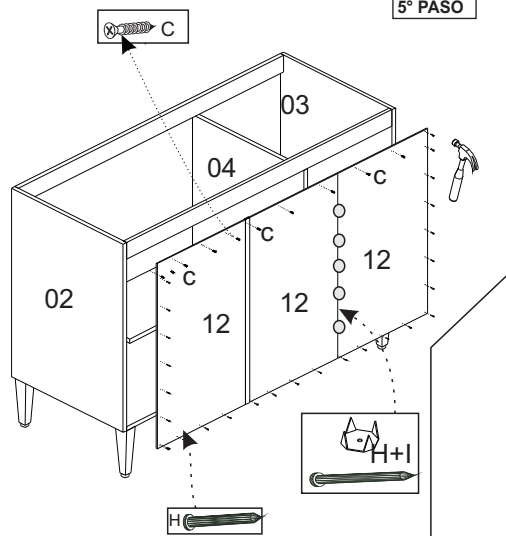

6º PASSO
6º STEP
6º PASO

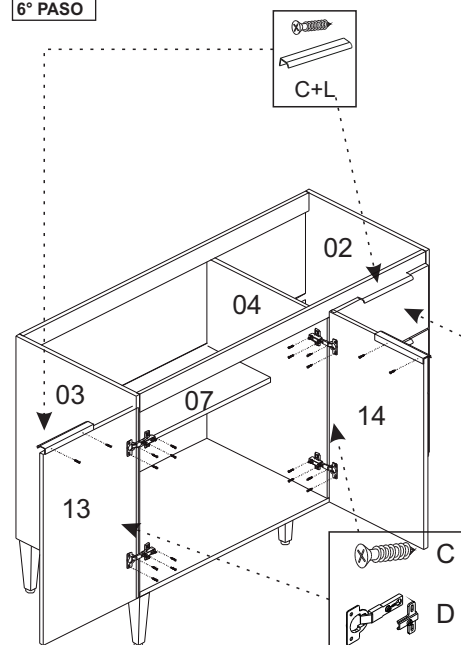







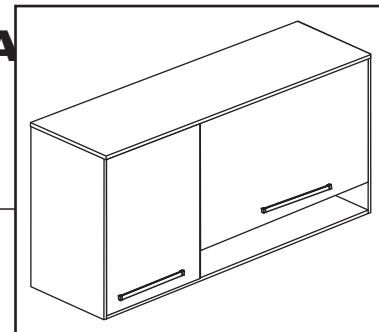

FERRAGENS / HARDWARE / EQUIPOS

Letter	Quantity	Description	Image
A	04	SUPORE PINO PIN SUPPORT SOPORTE DE PIN	
B	17	PARAFUSO 4 X 40 SCREW 4 X 40 TORNILLO 4 X 40	
C	82	PARAFUSO 3,5 X 14 SCREW 3,5 X 14 TORNILLO 3,5X14	
D	04	DOBRADIÇA SUPER ALTA 26 SUPER HIGH HINGE 26 BISAGRA SUPER ALTA 26	
E	09	CANTONEIRA CORNER ESQUINA	
F	28	CAVILHA 6 X 30 6 X 30 DOWEL CLAVIJA 6 X 30	
G	01	PERFIL H PROFILE H PERFIL H	
H	40	PREGO 10 X 10 NAIL 10 X 10 CLAVO 10 X 10	
I	06	FIXADOR DE FUNDO BOTTOM FIXER FIJADOR INFERIOR	
J	05	PARAFUSO 5 X 40 SCREW 5 X 40 TORNILLO 5 X40	
K	03	TRILHO METAL SLIDE DESILIZAR	
L	05	PUXADOR HANDLE MANEJAR	
M	05	SAPATA SHOE	

Para o puxador não se movimentar
pode ser utilizado cola instantânea para melhorar a fixação
To prevent the handle from moving
instant glue can be used to improve fixation
Para evitar que el mango se mueva
Se puede utilizar pegamento instantáneo para mejorar la fijación.



FERRAGENS

A		Parafuso 4,5 x 50
B		Prego 10 x 10
C		Cavilhas 6 x 30
D		Puxador
E		Parafuso 4 x 25
F		Dobradiça
G		Parafuso 3,5 x 14
H		Parafuso 4,0 x 30

