



JCM
m o v e l a r i a

Cristaleira Graça Graça Display Cabinet Vitrina Graça



Indicamos que a montagem dos produtos seja realizada com parafusadeira eléctrica e por um montador profissional.
We recommend that a professional furniture assembler assemble the product by using a cordless screwdriver.
Se recomienda que un montador de muebles profesional realice el montaje del producto con un destornillador eléctrico.



AVISO: Não nos comprometemos pelo mal-uso, montagem e fixação do produto à parede. Portanto, não somos responsáveis por danos e quedas do produto, eletrónicos e pertences neles contidos. É importante o uso de brocas e ferramentas compatíveis na montagem.
NOTICE: The company is not responsible for the misuse, assembly, and wall fixation, as well as the damages and falls that the products, electronics, and belongings therein might suffer. It is important to use suitable drills and tools to assemble the product.
ATENCIÓN: La empresa no se responsabiliza del mal uso, montaje y fijación del producto a la pared, así como de daños y caídas del producto, electrónicos u objetos. Es importante el uso de taladros y herramientas compatibles con el montaje.

Dica: para evitar possíveis avarias, use a embalagem do produto como apoio durante a montagem.
Tip: to avoid damages, use the product packaging as a base during the assembly.
Pista: para evitar daños, use el envase del producto como apoyo durante el montaje.

RELAÇÃO DE FERRAGENS | HARDWARE LIST | LISTADO DE HERRAJES

CANTONEIRA 04 FUROS	(A)	4-HOLE ANGLE BRACKET	(A)	REFUERZO DE ÁNGULO 4 AGUJEROS	(A)		03
CAVILHA 8x70	(B)	8x70 DOWEL	(B)	CLAVIJA 8x70	(B)		02
KIT DOBRADIÇA PORTA VIDRO	(C)	GLASS DOOR HINGE 	(C)	BISAGRA PUERTA DE VIDRIO	(C)		01
PARAFUSO 3,5x14	(D)	3.5x14 SCREW	(D)	TORNILLO 3,5x14	(D)		12
PARAFUSO 4,0x20	(E)	4.0x20 SCREW	(E)	TORNILLO 4,0x20	(E)		01
PARAFUSO 3,5x35 FLANG.	(F)	3.5x35 FLANGE SCREW	(F)	TORNILLO TIPO FLANGE 3,5x35	(F)		08
PARAFUSO 5x40	(G)	5x40 SCREW	(G)	TORNILLO 5x40	(G)		12
PARAFUSO MINIFIX	(H)	MINIFIX BOLT	(H)	PERNO MINIFIX	(H)		04
PINO SUPORTE PRATELEIRA	(I)	SHELF SUPPORT	(I)	SOPORTE DE ESTANTE	(I)		08
PREGO 8x8 C/C	(J)	8x8 NAIL	(J)	CLAVO 8x8	(J)		30
PUXADOR	(K)	HANDLE	(K)	TIRADOR	(K)		01
SUPORTE VIDRO	(L)	GLASS DOOR STOPPER	(L)	BATIENTE DE PUERTA DE VIDRIO	(L)		01
TAMBOR MINIFIX	(M)	MINIFIX CAM	(M)	CAJA DEL MINIFIX	(M)		04

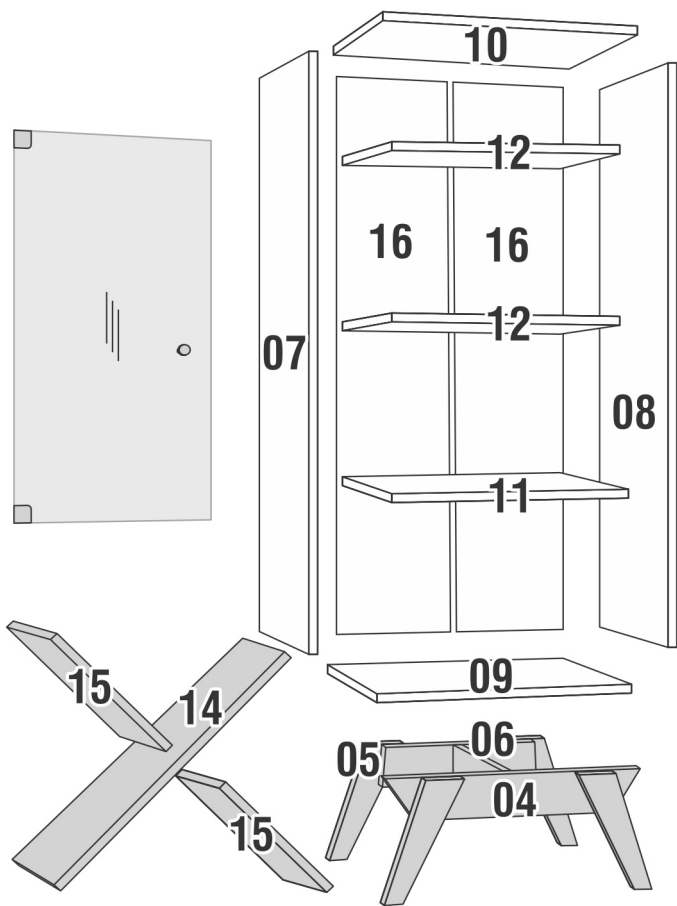
RELAÇÃO DE PEÇAS | PARTS LIST | LISTADO DE PARTES

09 Base
Bottom
Base 1Pc



10 Tampo
Top
Tapa 1Pc



11 Prateleira Fixa
Fixed Shelf
Estante Fijo 1Pc



12 Prateleira Solta
Loose Shelf
Estante Suelto 2Pcs

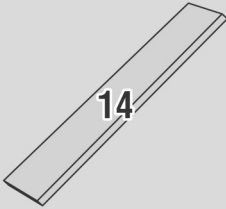

14 Divisão Maior Adega
Wine Rack Bigger Support
Suporte Grande de la Bodega 1Pc



15 Divisão Menor Adega
Wine Rack Smaller Support
Suporte Pequeno de la Bodega 2Pcs



04 Rodapé Frontal
Front Toe
Zócalo Frontal 1Pc



05 Rodapé Traseiro
Back Toe
Zócalo Trasero 1Pc



06 Rodapé Interno
Internal Toe
Zócalo Interno 1Pc



16 Costas
Back
Trasero 2Pcs



07 Lateral Esquerda
Left Side
Lateral Izquierdo 1Pc



08 Lateral Direita
Right Side
Lateral Derecho 1Pc

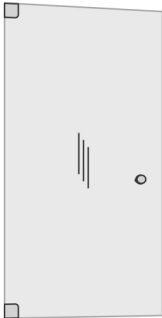

09 Porta
Door
Puerta 1Pc



10 Pé
Foot
Pata 4Pcs

Passo 01 IDENTIFIQUE AS PEÇAS JÁ COLOCANDO OS SEUS ACESSÓRIOS. PARAFUSE A PEÇA 11 NAS PEÇAS 7 E 8 COM PARAFUSO 5x40 (G).

Step 01 IDENTIFY THE PARTS AND FASTEN THEIR HARDWARE. FASTEN PART 11 TO PARTS 7 AND 8 WITH 5x40 SCREW (G).

Paso 01 IDENTIFIQUE LAS PARTES Y FIJE SUS HERRAJES. FIJE LA PARTE 11 A LAS PARTES 7 Y 8 CON TORNILLO 5x40 (G).

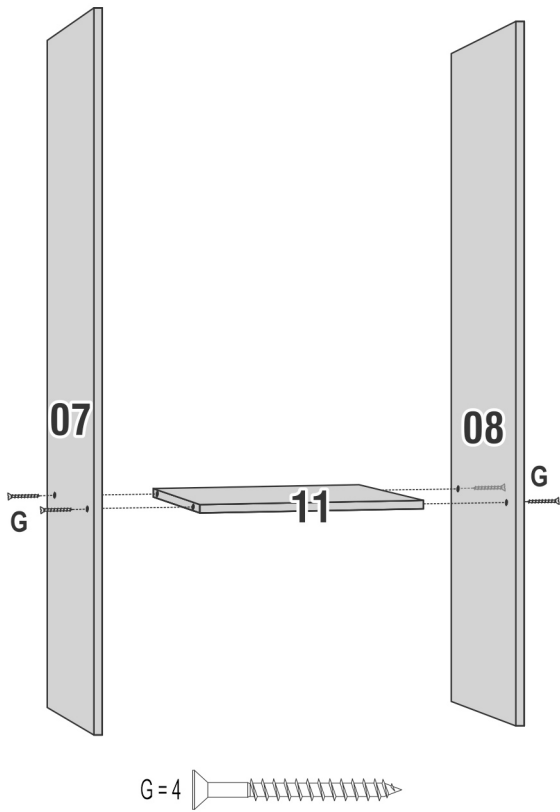

Passo 02 ENCAIXE AS PEÇAS 10 NAS PEÇAS 7 E 8 COM MINIFIX (H+M) JÁ COLOCANDO O PINO VIDRO (L). PARAFUSE A PEÇA 9 NAS PEÇAS 7 E 8 COM PARAFUSO 5x40 (G).

Step 02 FASTEN PARTS 10 TO PARTS 7 AND 8 WITH MINIFIX (H+M), AND INSERT THE GLASS DOOR STOPPER (L). FASTEN PART 9 TO PARTS 7 AND 8 WITH 5x40 SCREW (G).

Paso 02 FIJE LAS PARTES 10 A LAS PARTES 7 Y 8 CON MINIFIX (H+M), Y PONGA EL BATIENTE DE PUERTA DE VIDRO (L). FIJE LA PARTE 9 A LAS PARTES 7 Y 8 CON TORNILLO 5x40 (G).

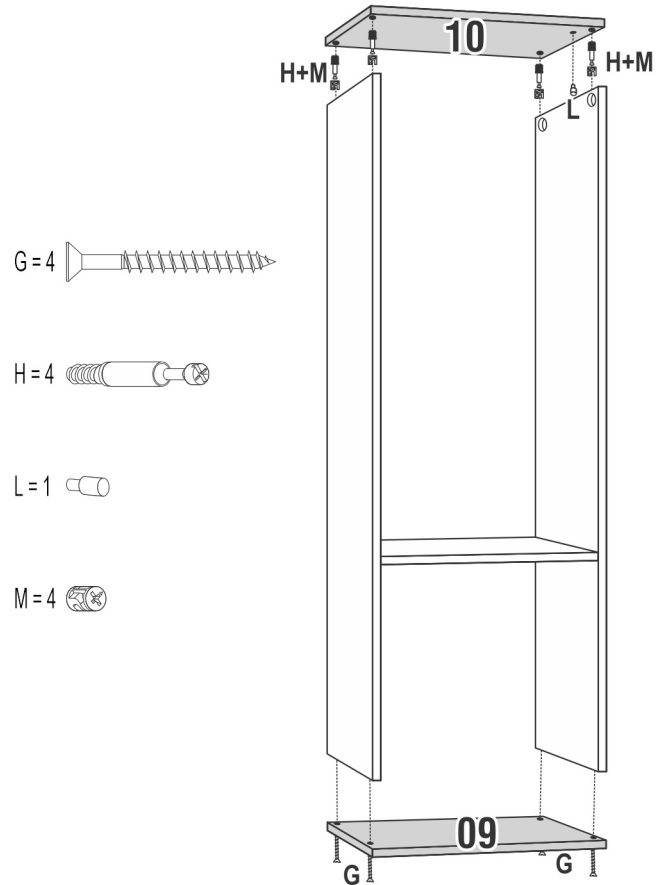

Passo 03 PARAFUSE OS PÉS NA PEÇA 9 COM PARAFUSO 5x40 (G).

Step 03 FASTEN THE FEET TO PART 9 WITH 5x40 SCREW (G).

Paso 03 FIJE LAS PATAS A LA PARTE 9 CON TORNILLO 5x40 (G).

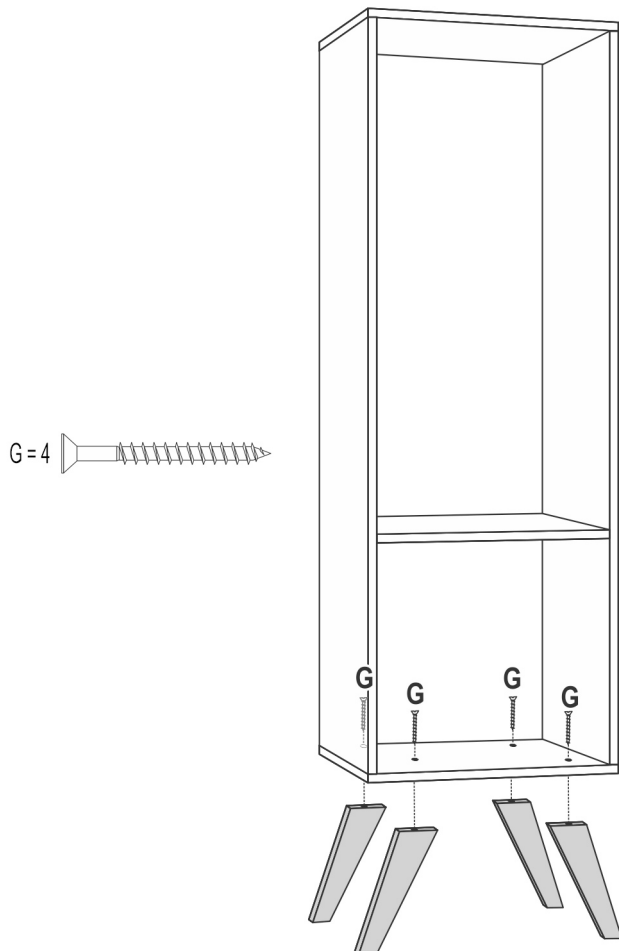

Passo 04 FAÇA A MONTAGEM DOS PÉS CONFORME A IMAGEM COM AS RESPECTIVAS FERRAGENS.

Step 04 USE THE HARDWARE TO FASTEN THE FEET, ACCORDING TO THE PICTURES.

Paso 04 UTILICE LOS HERRAJES PARA FIJAR LAS PATAS, SEGÚN EL DISEÑO.

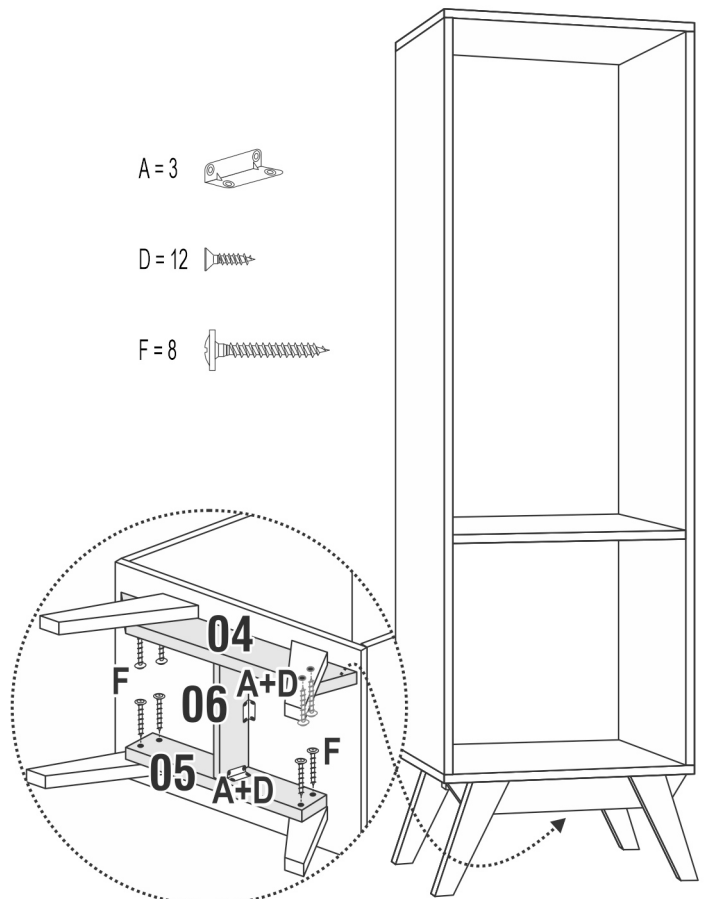

Passo 05 PREGUE AS COSTAS COM PREGO 8x8 C/C (J).

Step 05 FASTEN THE BACK WITH 8x8 NAILS (J).

Paso 05 FIJE LA TRASERA CON CLAVOS 8x8 (J).

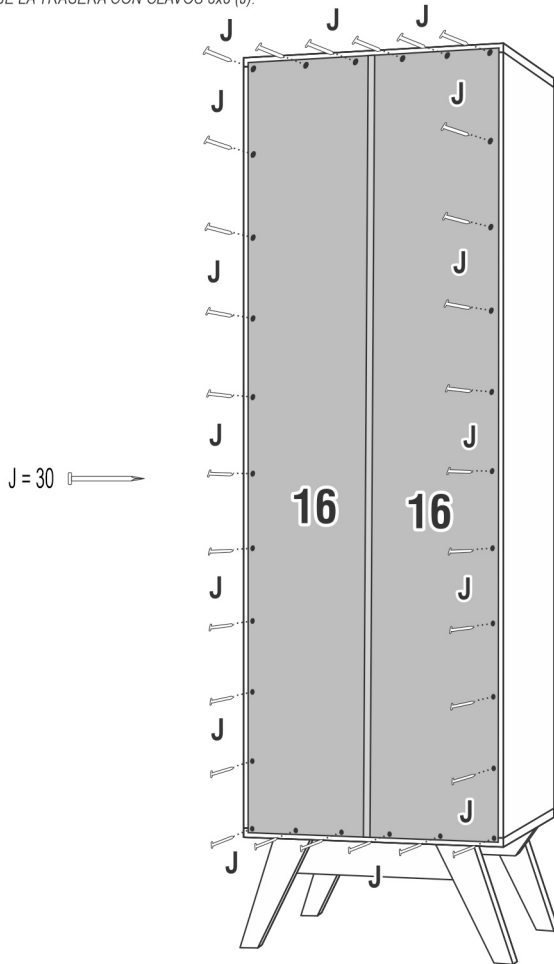

Passo 06 ENCAIXE AS PEÇAS 15 NA 14 COM CAVILHA 7x80 (B).

Step 06 ATTACH PARTS 15 TO PART 14 WITH 7x80 DOWEL (B).

Paso 06 UNA LAS PARTES 15 A LA PARTE 14 CON CLAVIJA 7x80 (B).

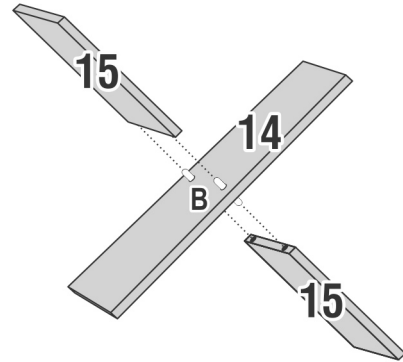

B = 2

Passo 07 MONTE AS PRATELEIRAS 12 COM PINO SUPORTE (I).

Step 07 INSERT THE SHELVES (12) WITH THEIR SUPPORTS (I).

Paso 07 PONGA LOS ESTANTES (12) CON SUS SOPORTES (I).

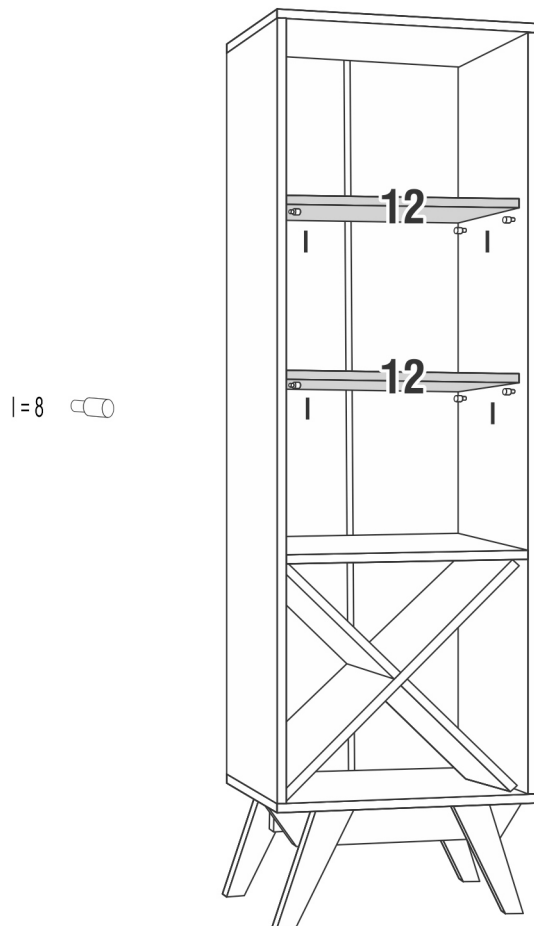

I = 8

Passo 08 MONTE E FIXE AS PORTAS 10 NAS PEÇAS 6, 7 E 8 COM AS RESPECTIVAS FERRAGENS.

Step 08 USE THE HARDWARE TO FASTEN THE DOORS (10) TO PARTS 6, 7, AND 8.

Paso 08 UTILICE LOS HERRAJES PARA FIJAR LAS PUERTAS (10) A LAS PARTES 6, 7 Y 8.

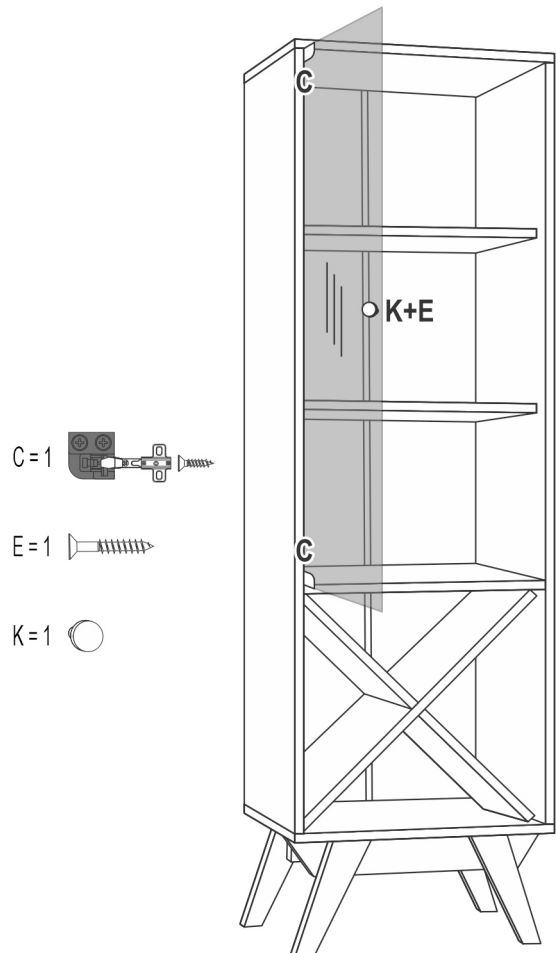

C = 1

E = 1

K = 1