



ESTANTE VINTAGE PARIS

ATENÇÃO/ ATTENTION / ATENCION

VÍDEO DE MONTAGEM DISPONÍVEL NO SITE / ASSEMBLY VIDEO AVAILABLE ON THE SITE
VÍDEO DE MONTAJE DISPONIBLE EN EL SITIO

www.olivar.com.br

DIMENSÕES DO PRODUTO / PRODUKT DIMENSIONS / DIMENSIONS PRODUCT - WxDxH / LxDxA - 550 X 423 X 1618 MM



Vídeo de Montagem
Assembly video
Vídeo de Montaje

PEÇAS NUMERADAS / NUMBERED PARTS /
PIEZAS NUMERADAS

EX: 1915X-X 01(peça/ piece/ pieza number)

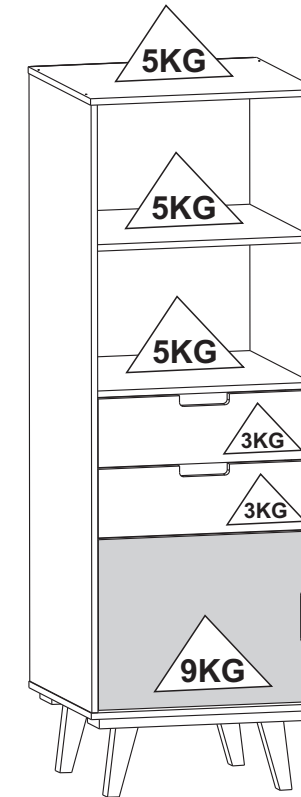
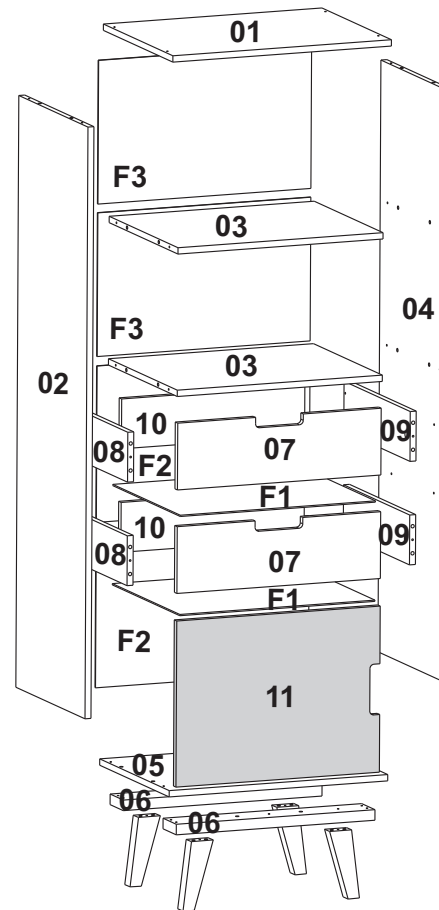

ATENÇÃO/ ATENCION/ ATTENTION
ESTE PRODUTO NÃO PODE SER ARRASTADO.
THIS PRODUCT MUSTNOT BE DRAGGED.
ESTE PRODUCTO NO SE PUEDE ARRASTRAR

MONTAR O PRODUTO SOBRE A EMBALAGEM,
EVITANDO DANOS NA PINTURA.
ACONSELHAMOS QUE A MONTAGEM DO PRODUTO
SEJA POR UM PROFISSIONAL.

SETUP THE PRODUCT ON TOP OF THE PACKAGING, AVOIDING
DAMAGE TO THE PAINT.
WE RECOMMEND THAT THE INSTALLATION IS DONE BY
A PROFESSIONAL.

MONTAR EL PRODUCTO EN EL PAQUETE,
EVITAR LESIONES EN PINTURA.
AVISAMOS QUE EL MONTAJE DEL PRODUCTO
SEA UN PROFESIONAL.

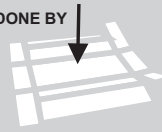

CUIDADOS ESPECIAIS

LIMPEZA- Pano limpo umedecido em água e sabão neutro.
BRILHO- Flanela seca.

SPECIAL CARE

CLEANING- Clean cloth moistened with water and mild soap.
SHINE- Dry cloth.

CUIDADOS ESPECIALES:

LIMPIEZA- Paño limpio humedecido con agua y un jabón suave.
BRIGHT- Franela seco.

ATENÇÃO / ATTENTION / ATENCION

Nunca utilizar óleos, lustra móveis; produtos abrasivos, saponáceos,
esponja de aço e outros.

Never use oils, polish furniture , abrasive products, soaps,
steel sponge and others.

Nunca use aceites, pulimentos; abrasivos, jabones,
esponja de acero y otros.

Ferramentas necessárias / Necessary tools / Herramientas Necesarias
(não fornecidas) (not provided) (No proporcionadas)

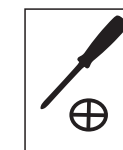
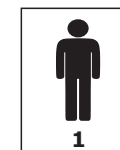

**MEDIDA UTILIZADA EM MM /
UNIT MEASURE USED
IS MILLIMETERS (MM)**

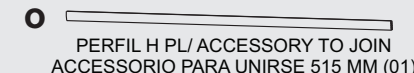
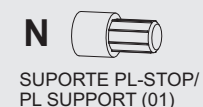
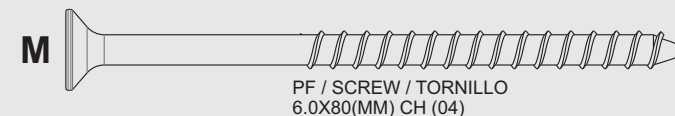
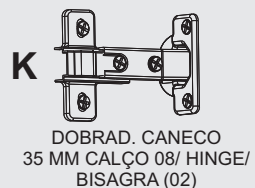
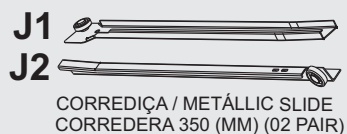
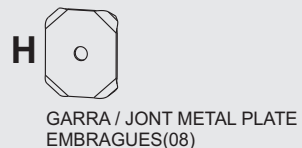
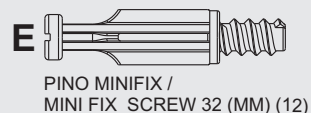
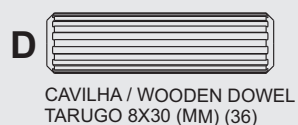

ITEM		DESCRIÇÃO DA PEÇAS / DESCRIPTION OF PARTS / UNIT MEASURE USED IS MILLIMETERS (MM)	CORES/ COLORS/ COLORES					
CÓDIGO CODE	Nº		NOME/NAME/NOMBRE	MEDIDAS / MEASURES (MM)	TIPO TYPE	QUANT AMOUNT CANTIDAD	BRANCO WHITE BLANCO	PRETO BLACK NEGRO
11355	01	TAMPO/ TOP	550X420X15	MDP	01	1/05	1/07	1/18
11351	02	LATERAL ESQ./ LEFT SIDE/ LADO IZQUIERDO	1400X418X15	MDP	01	2/05	2/07	2/18
11353	03	PRATEL. SUP.INF/ HIGHER BOTTON SHELF/ ESTANTE SUP.INF.	516X416X15	MDP	02	3/05	3/07	3/18
11352	04	LATERAL DIREITA/ RIGHT SIDE/ LADO DERECHO	1400X418X15	MDP	01	4/05	4/07	4/18
11350	05	BASE	550X420X15	MDP	01	5/05	5/07	5/18
12002	06	REFOR. PÉ/ FOOT REINFORCEMENT/ REFUERZO PIE	500X80X25	MDF	02	6/05	6/07	6/18
11359	07	FRENTE GAV./ DRAWER FRONT / FRENTE DE CÁJON	512X158X15	MDF	02	7/05	7/07	7/18
11356	08	LAT. GAV. ESQ./ LEFT DRAW. SIDE/ LAD. CAJ. IZQ.	350X118X15	MDP	02	8/05	8/07	8/18
11357	09	LAT. GAV. DIR./ RIGHT DRAW. SIDE/ LAD. CAJ. DER	350X118X15	MDP	02	9/05	9/07	9/18
11358	10	CONT. FRENT. GAV./AGAINST DRAWER FRONT/ CONTRA EL FRENTE DEL CAJÓN	461X118X15	MDP	02	10/05	10/07	10/18
11360	11	PORTA/ DOOR/ PUERTA	512X393X15	MDF	01	11/05	11/07	11/18
11361	F1	FUNDO GAV. / DRAWER BACKGROUND/ FONDO CÁJON	491X358X3	TRI	02	F1/05	F1/07	F1/18
11362	F2	FUNDO TRÁS / BACK / TRASEIRO	536X370X03	TRI	02	F2/05	F2/07	F2/18
11363	F3	FUNDO TRÁS / BACK / TRASEIRO	536X340X03	TRI	02	F3/05	F3/07	F3/18
438	A	PF. / Screw / Tornillo 4,0x40(MM) CH			16			
12774	B	PF./ Screw / Tornillo 4,0x35(MM) FL			10			
986	C	PF./ Screw / Tornillo 3,5x14(MM) CRR			32			
137	D	Cavilha / Wooden Dowel / Tarugo 8x30(MM)			36			
532	E	Pino Minifix / Minifix Screw 32(MM)			12			
508	F	Tambor Minifix / Minifix Round Nut 15(MM)			12			
509						BRANCO		
7125	G	Tampa Minifix / Minifix Cover Cap 15(MM)			12		PRETO	
511								CAFÉ
911	H	Garra/ Jont Metal Plate/ Embragues			08			
248	I	Prego / Nail / Clavo 8x8(MM)			70			
12175	J	Corred./Metallic Slid 350 (MM) BIG FER (02 Pair)			02			
10556	K	Dobradça Caneco 35MM Calço 08/ Hinge/ Bisagra			02			
12076	L	Pé Madeira vintage/ Wood Foot Vintage / Pies Madera Vintage 170 mm			04	MOGNO	MOGNO	MOGNO
11710	M	PF. / Screw / Tornillo 6,0x80(MM) CH			04			
12735						BRANCO		
13352	N	Suporte PI / Support PL			01		PRETO	
339								CAFÉ
12773	O	Perfil H Pl. / Accessory To Join/ Accessorio P. Unirse 515 (MM)			01			
		Certif. de Garant./ Warranty Certif.			01			

1

Obs: As peças pintadas nos passos são apenas ilustrativas.
The parts painted in the steps are illustrative only.
Las partes pintadas en los pasos son solo ilustrativas.

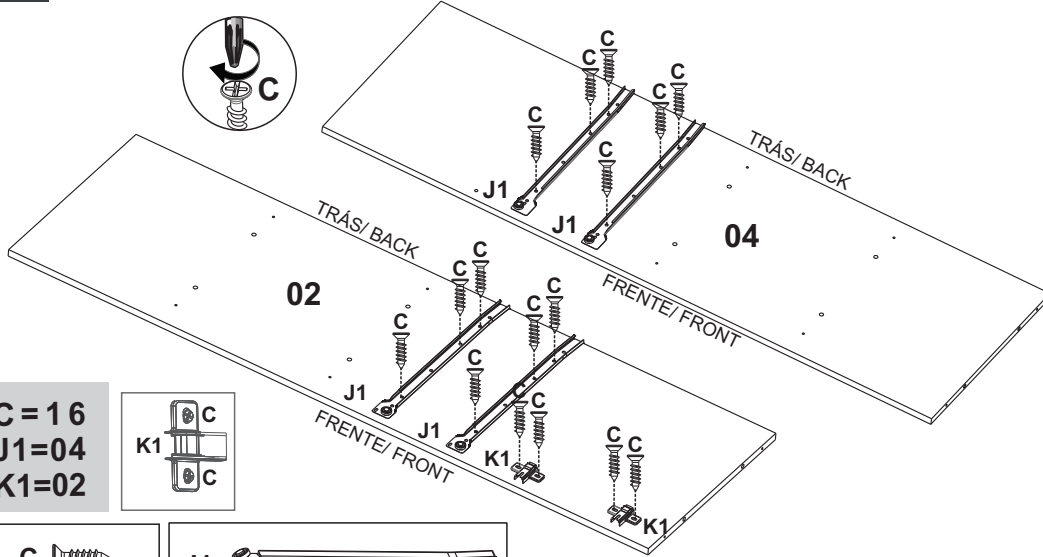

C = 16
J1 = 04
K1 = 02

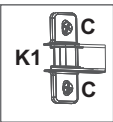

C 
3,5x14 CRR

J1 
350MM

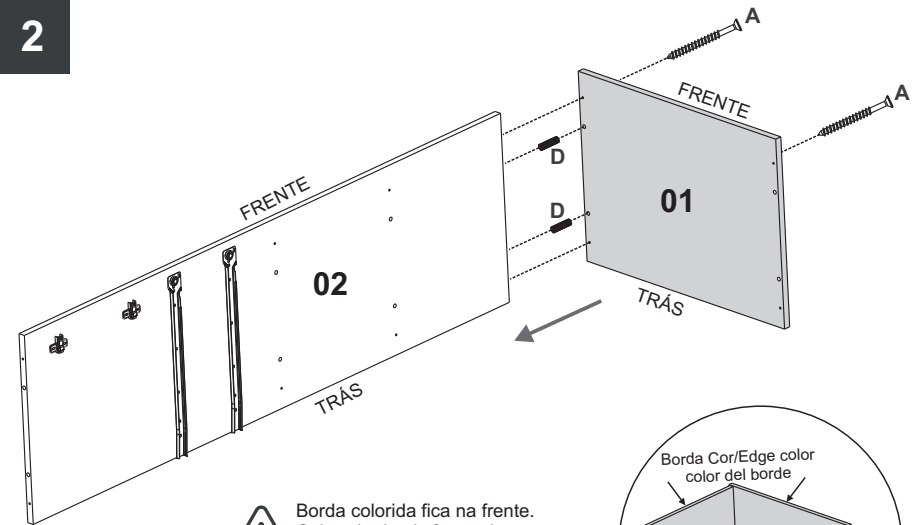
2

Borda colorida fica na frente.
Colored edge is forward.
El borde de color está hacia adelante

A = 02
D = 02

A 
4.0X40 CH

D 
8X30 MM

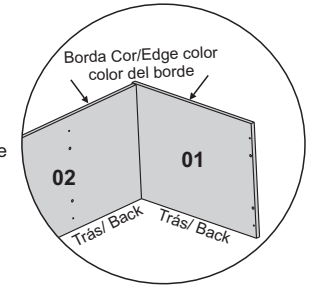
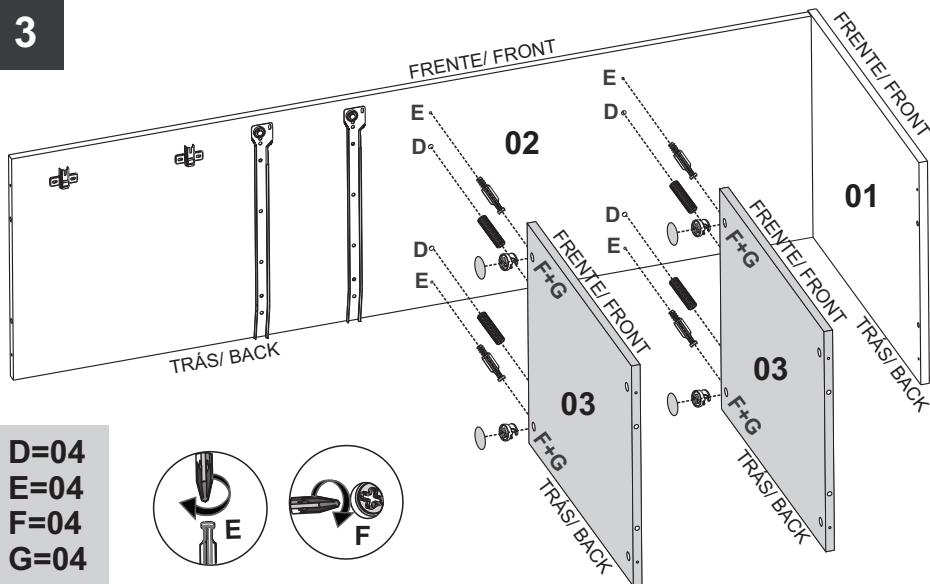
**3**

D = 04
E = 04
F = 04
G = 04



D 
8X30 MM

E 

F 

G 

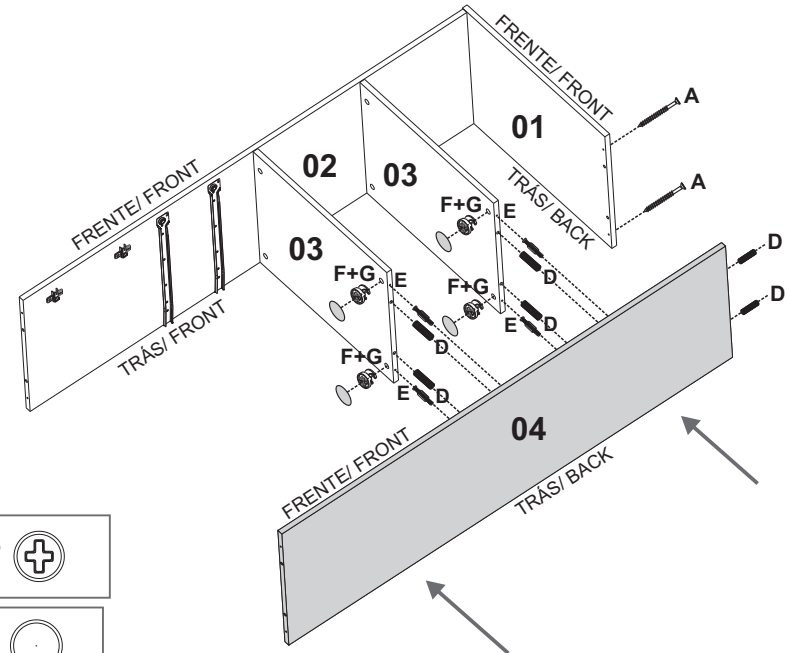
4

A = 02
D = 06
E = 04
F = 04
G = 04

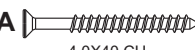
A 
4.0X40 CH

D 
8X30 MM

F 

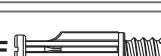
E 

G 

5

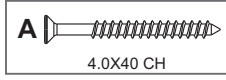
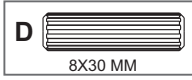
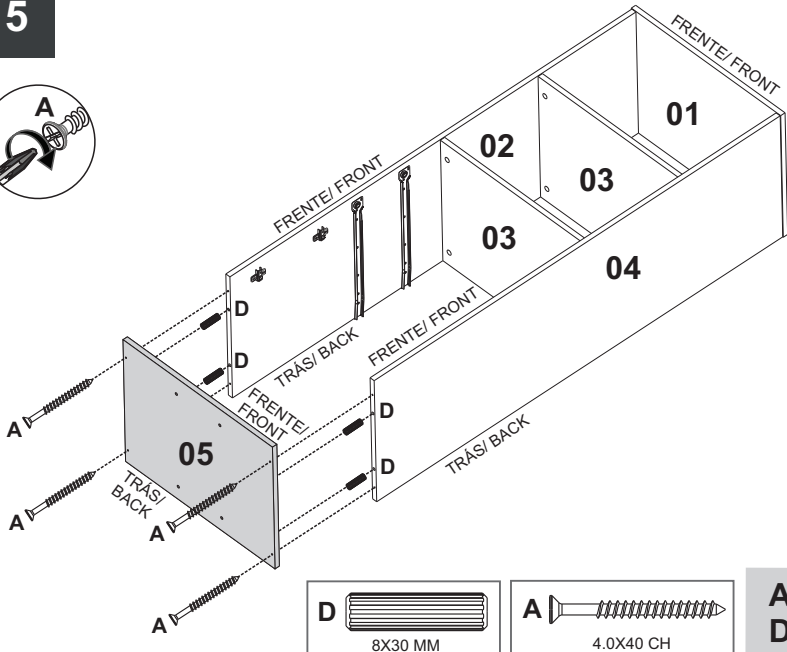

A=04
D=04

6

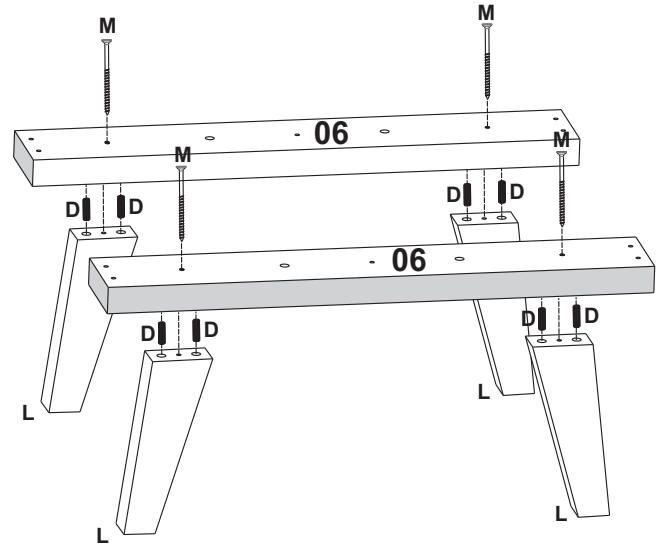
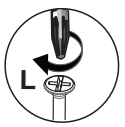

D=08
L=04
M=04

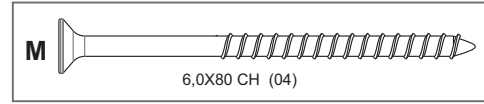
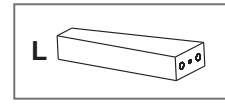
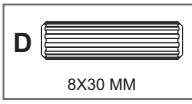

! FIXAÇÃO PÉS/
LEG FIXATION/
FIXACION PIES

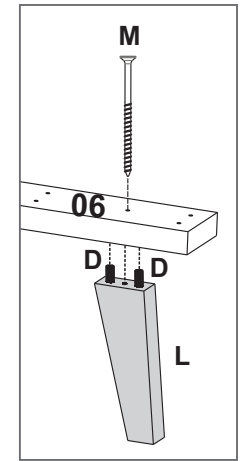

7

ATENÇÃO/ ATTENTION / ATENCION

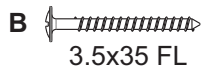

borda cor p frente/
fur edge front/
borde color frontal

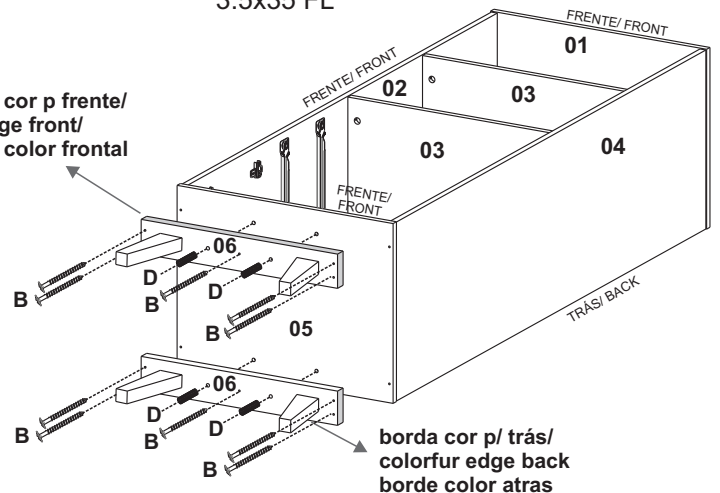

borda cor p trás/
colorfur edge back
borde color atras

B=10
D=04

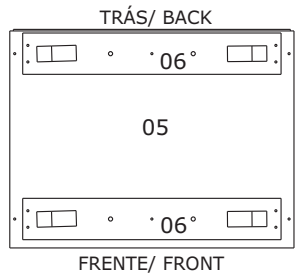
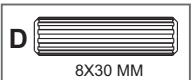
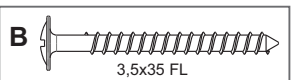

8

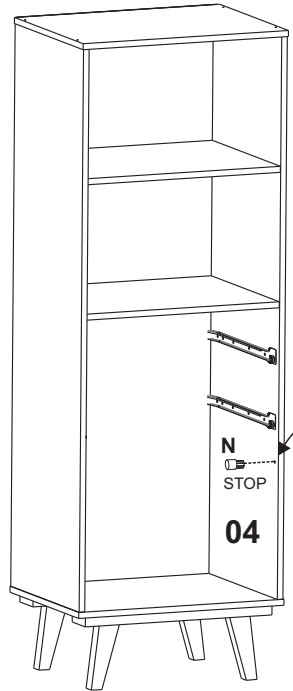

N=01

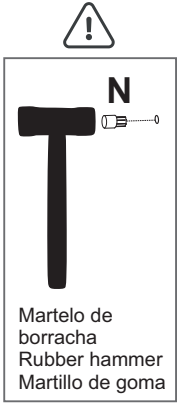
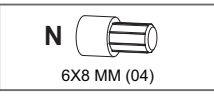

9

ENCAIXAR / TO FIT IN

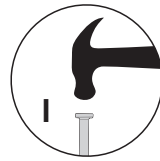
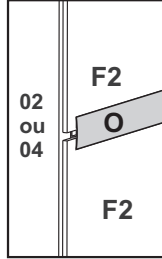

H=08
I=60
O=01

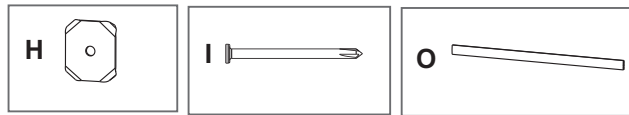

ENCAIXAR / TO FIT IN

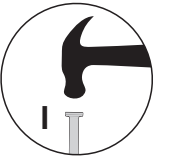
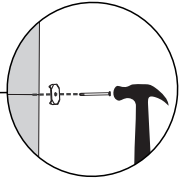
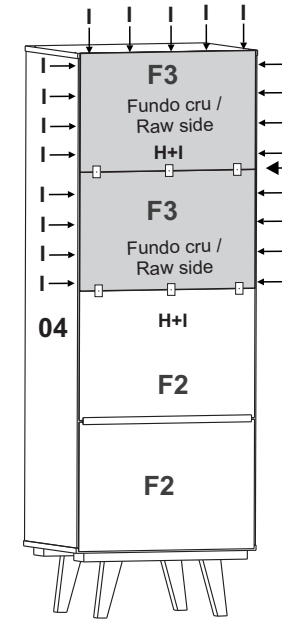
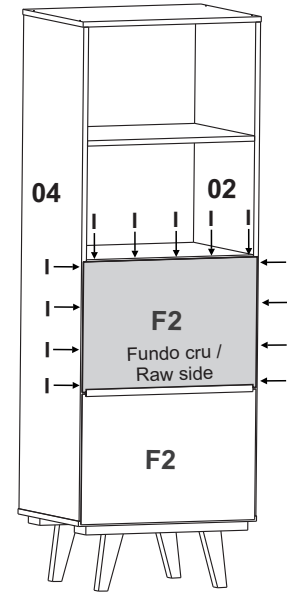
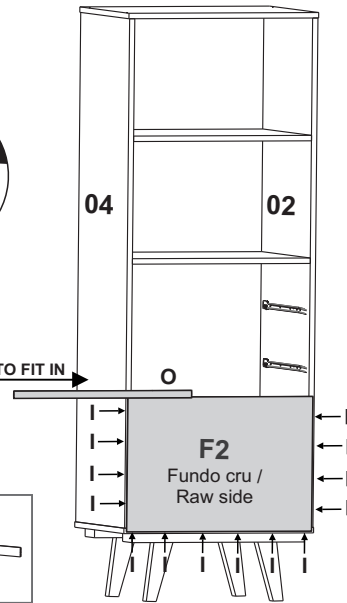

10

MONTAGEM GAVETA / ASSEMBLY OF THE DRAWER / MONTAJE LE CĂJON

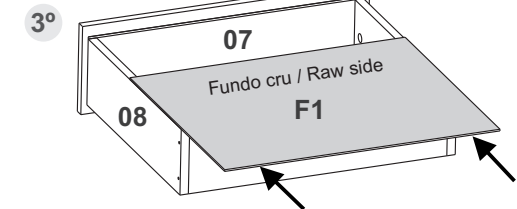
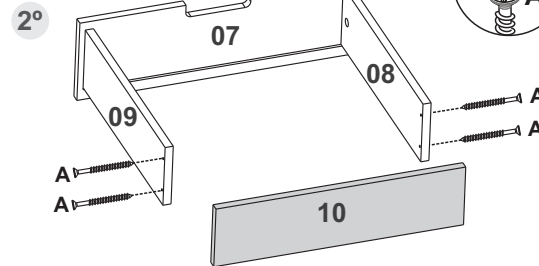
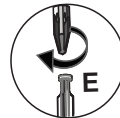
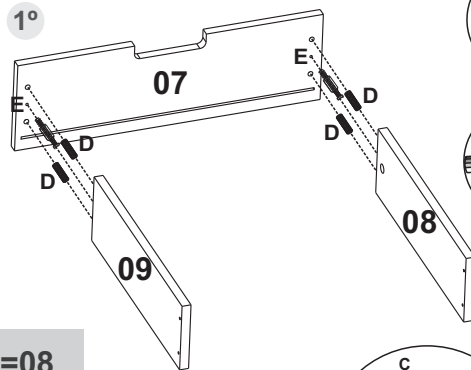

A=08
C=12
D=08
E=04
F=04
G=04
I=10
J2=04

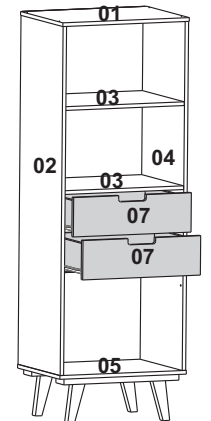
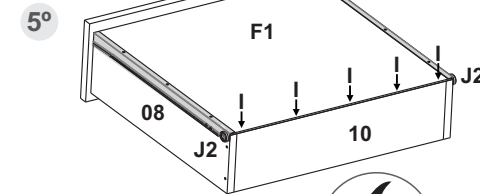
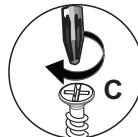
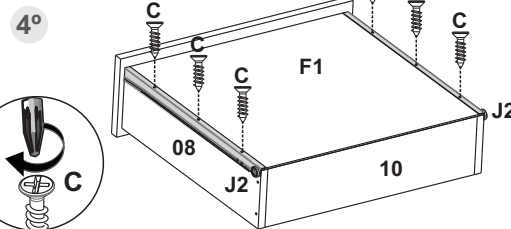
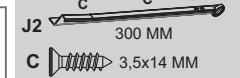
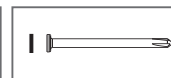
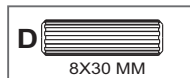
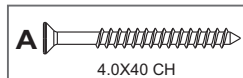

11

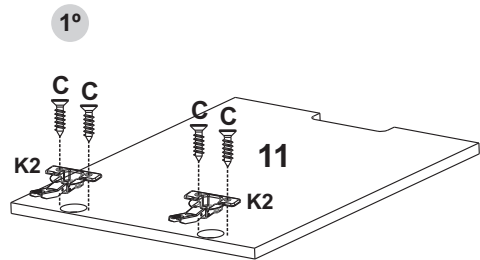

**! REGULAR E APERTAR /
ADJUST AND TIGHTEN /
AJUSTE Y APRIETE**

**FIXAR DOBRADIÇAS /
FIXING THE HINGE /
BISAGRA**

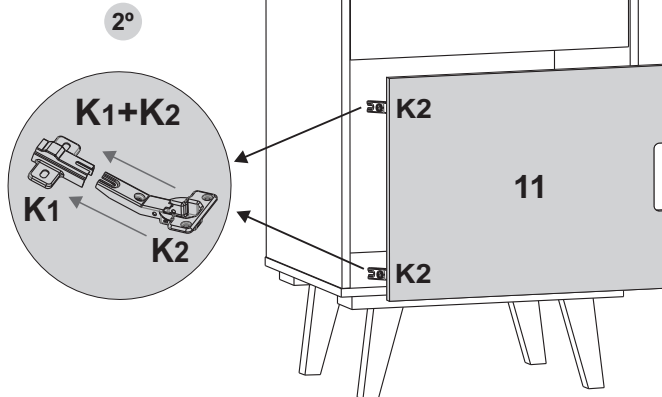
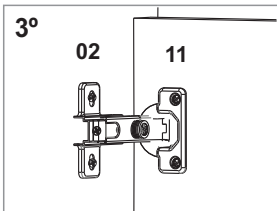
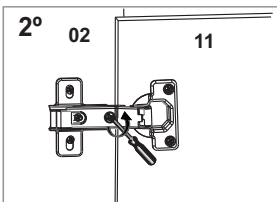
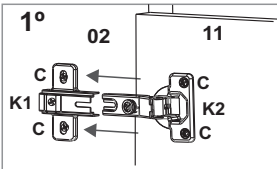

NOTA: ACONSELHAMOS PARAFUSAR O PRODUTO NA PAREDE, EVITANDO ACIDENTES.
WE ADVISE SCREW THE PRODUCT ON THE WALL, AVOIDING ACCIDENT.
ACONSEJAMOS ATORNILLAR EL PRODUCTO EN LA PAREDE, EVITANDO ACCIDENTES.

