

HO5120 - HOME

Manual de Montagem Assembly Instructions Instrucción de Montaje

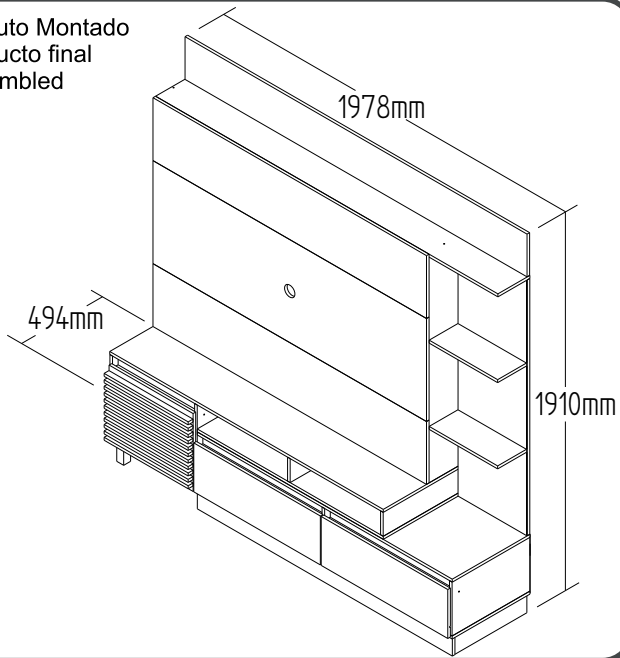

Produto Montado
Producto final
Assembled



1º

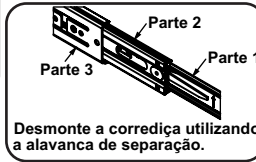

Desmonte a correção utilizando a alavanca de separação.

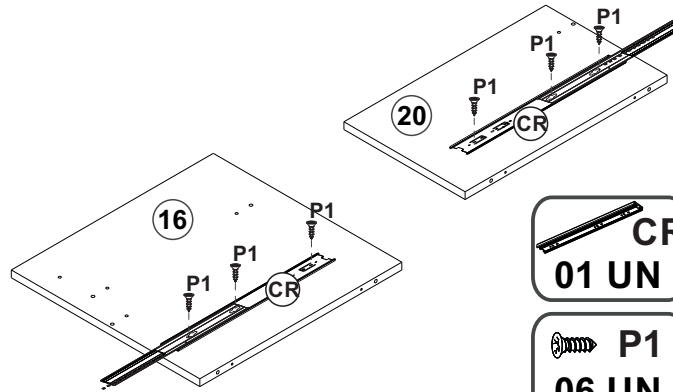
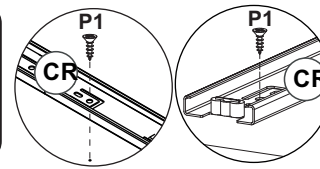

CR
01 UN

P1
06 UN

2º

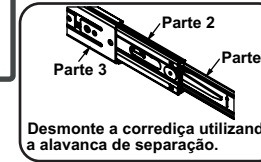

Desmonte a correção utilizando a alavanca de separação.

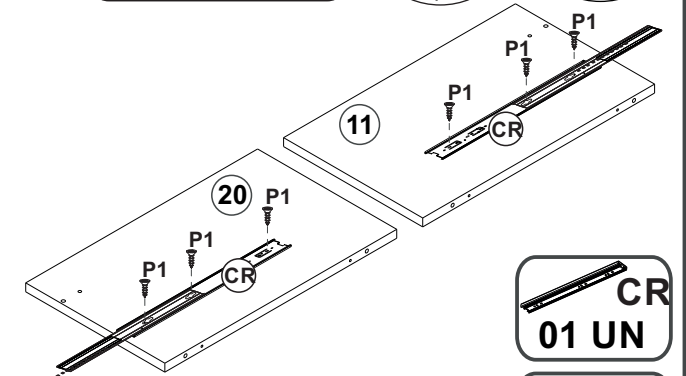
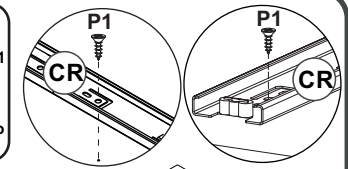

CR
01 UN

P1
06 UN

3º

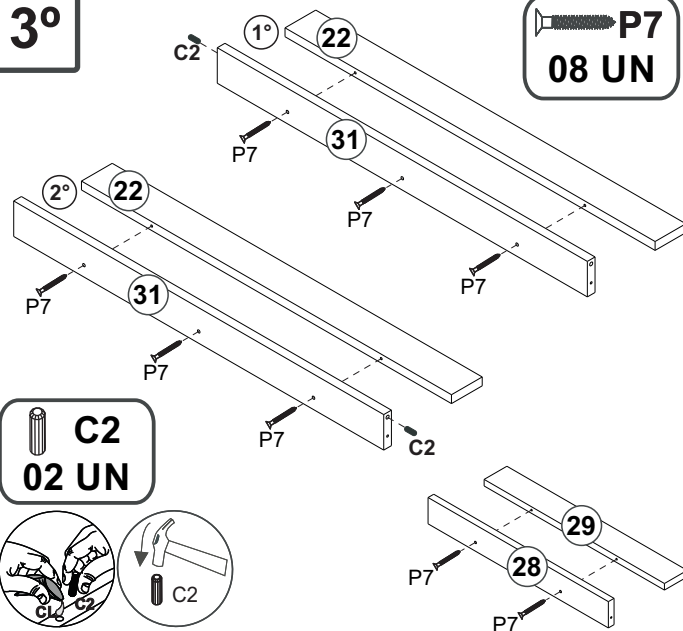

P7
08 UN

C2
02 UN



4º

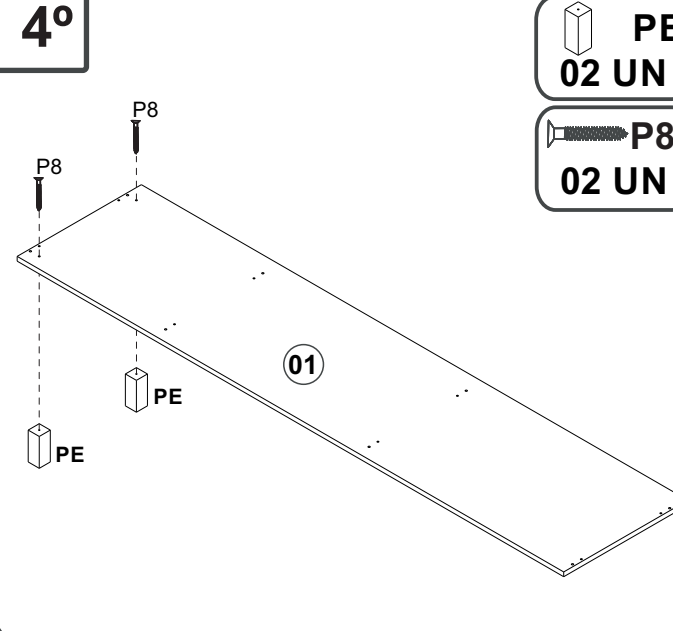

PE
02 UN

P8
02 UN

5º

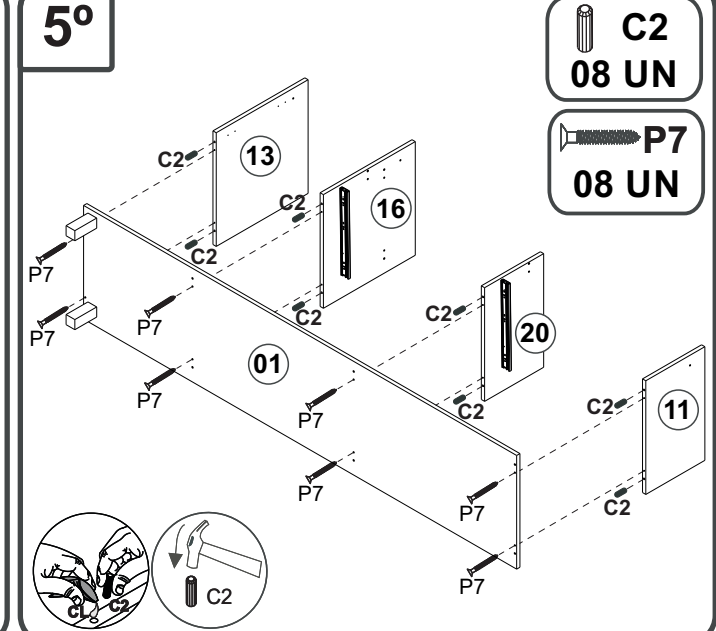

C2
08 UN

P7
08 UN



HO5120 - HOME

Manual de Montagem
Assembly Instructions
Instrucción de Montaje

decibal

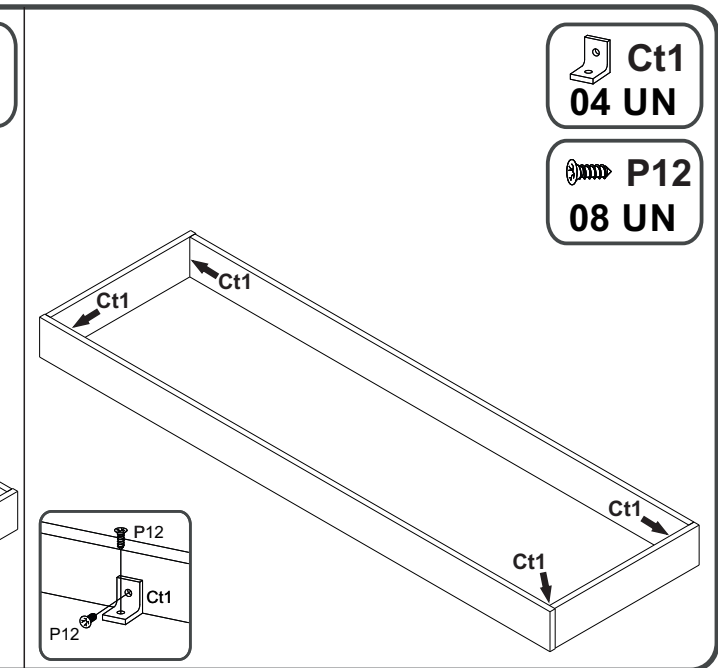
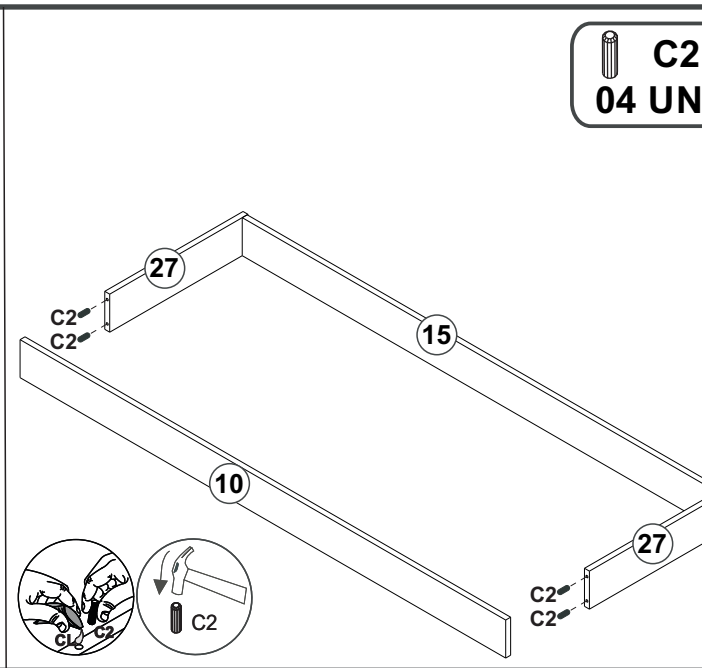
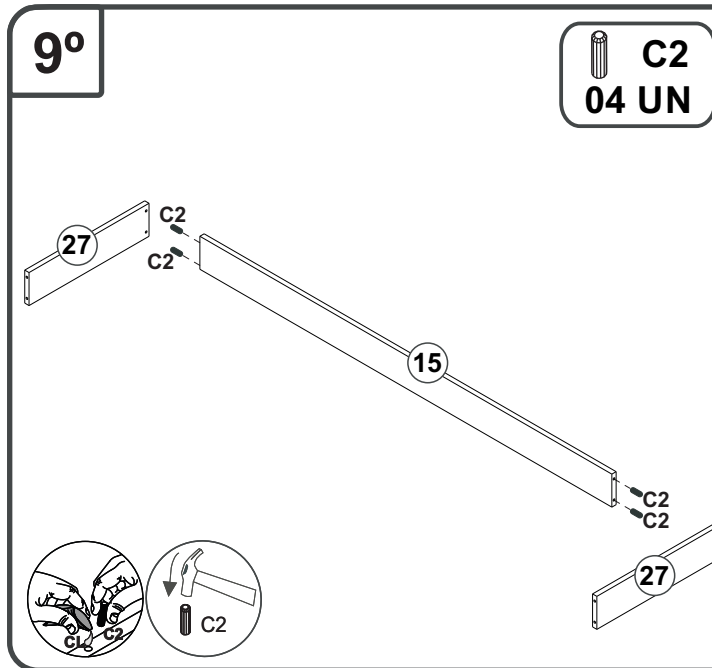
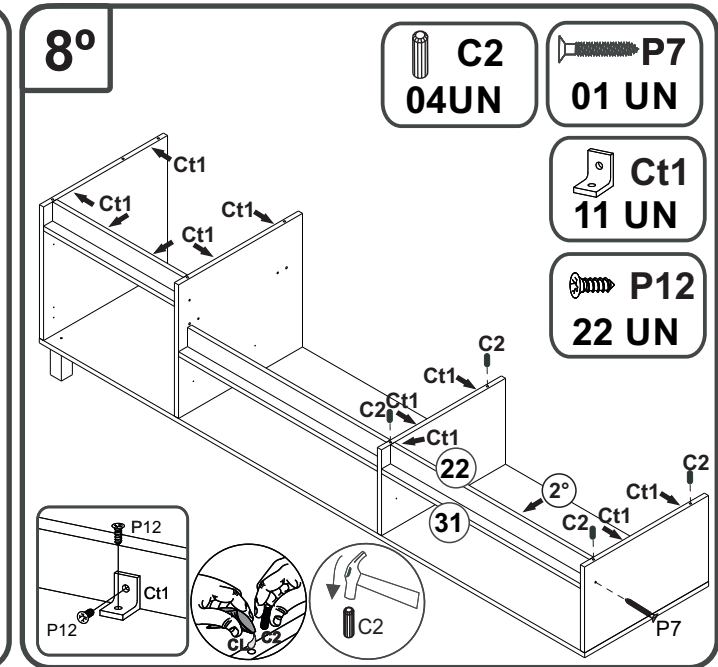
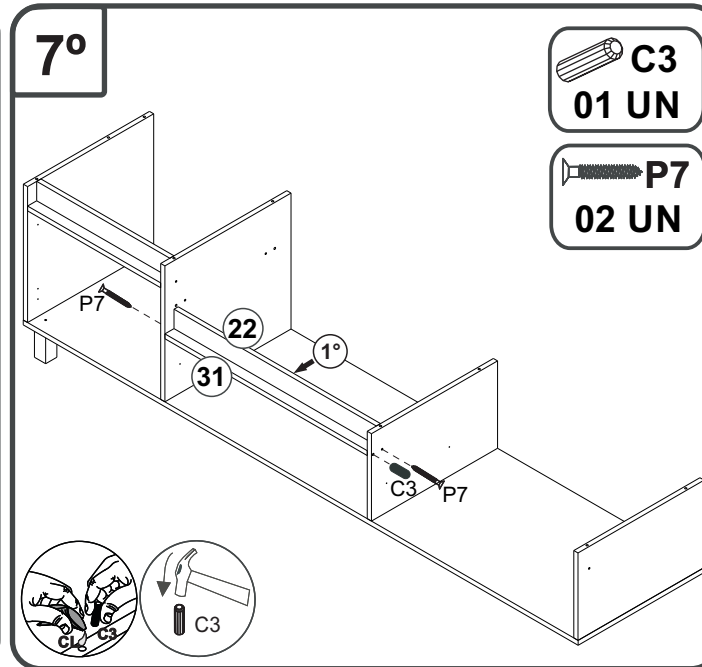
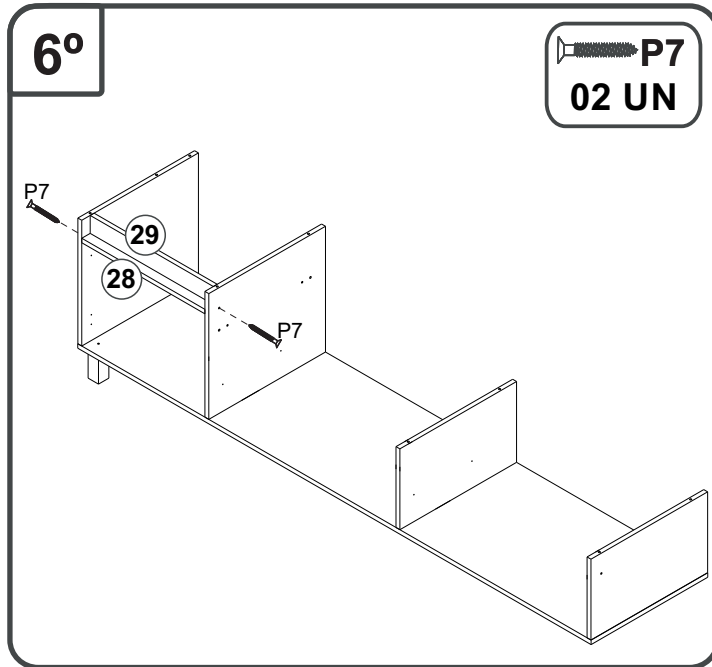

HO5120 - HOME

Manual de Montagem
 Assembly Instructions
 Instrucción de Montaje



10°

Pe1 08 UN	Ct1 12 UN
Pr1 08 UN	P12 24 UN

Diagram 10 shows the assembly of the main frame structure. It includes a detailed view of the frame with parts labeled Pe1, Ct1, Pr1, and P12. An inset shows the installation of P12 into Ct1.

11°

C3 04 UN

Diagram 11 shows the installation of C3 into the frame. It includes a detailed view of the frame with parts labeled C3 and 06. An inset shows the installation of C3 into the frame.

12°

P11 04 UN
C2 02 UN
P5 02 UN

Diagram 12 shows the installation of P11, C2, and P5 into the frame. It includes a detailed view of the frame with parts labeled P11, C2, P5, and 06. An inset shows the installation of C2 into the frame.

13°

C2 06 UN	P7 02 UN
C3 04 UN	

Diagram 13 shows the installation of C2 and P7 into the frame. It includes a detailed view of the frame with parts labeled C2, P7, C3, and 06. An inset shows the installation of C3 into the frame.

14°

C2 01 UN	P7 04 UN
B 04 UN	P6 04 UN

Diagram 14 shows the installation of C2, P7, B, and P6 into the frame. It includes a detailed view of the frame with parts labeled C2, P7, B, P6, and 03. An inset shows the installation of B into the frame.

15°

B 02 UN
C2 06 UN

Diagram 15 shows the installation of B and C2 into the frame. It includes a detailed view of the frame with parts labeled B, C2, and 21. An inset shows the installation of B into the frame.

HO5120 - HOME

Manual de Montagem
 Assembly Instructions
 Instrucción de Montaje



16°

B
02 UN

C2
04 UN

P7
02 UN

P6
04 UN

17°

P7
02 UN

P6
03 UN

18°

B
02 UN

P7
02 UN

19°

B
02 UN

P7
02 UN

M1
02 UN

M1

P7

20°

FX
03 UN

Pr1
52 UN

HO5120 - HOME

Manual de Montagem
Assembly Instructions
Instrucción de Montaje



21°

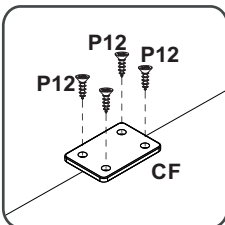
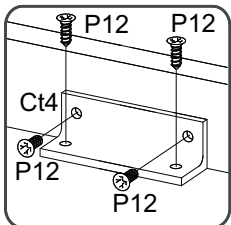
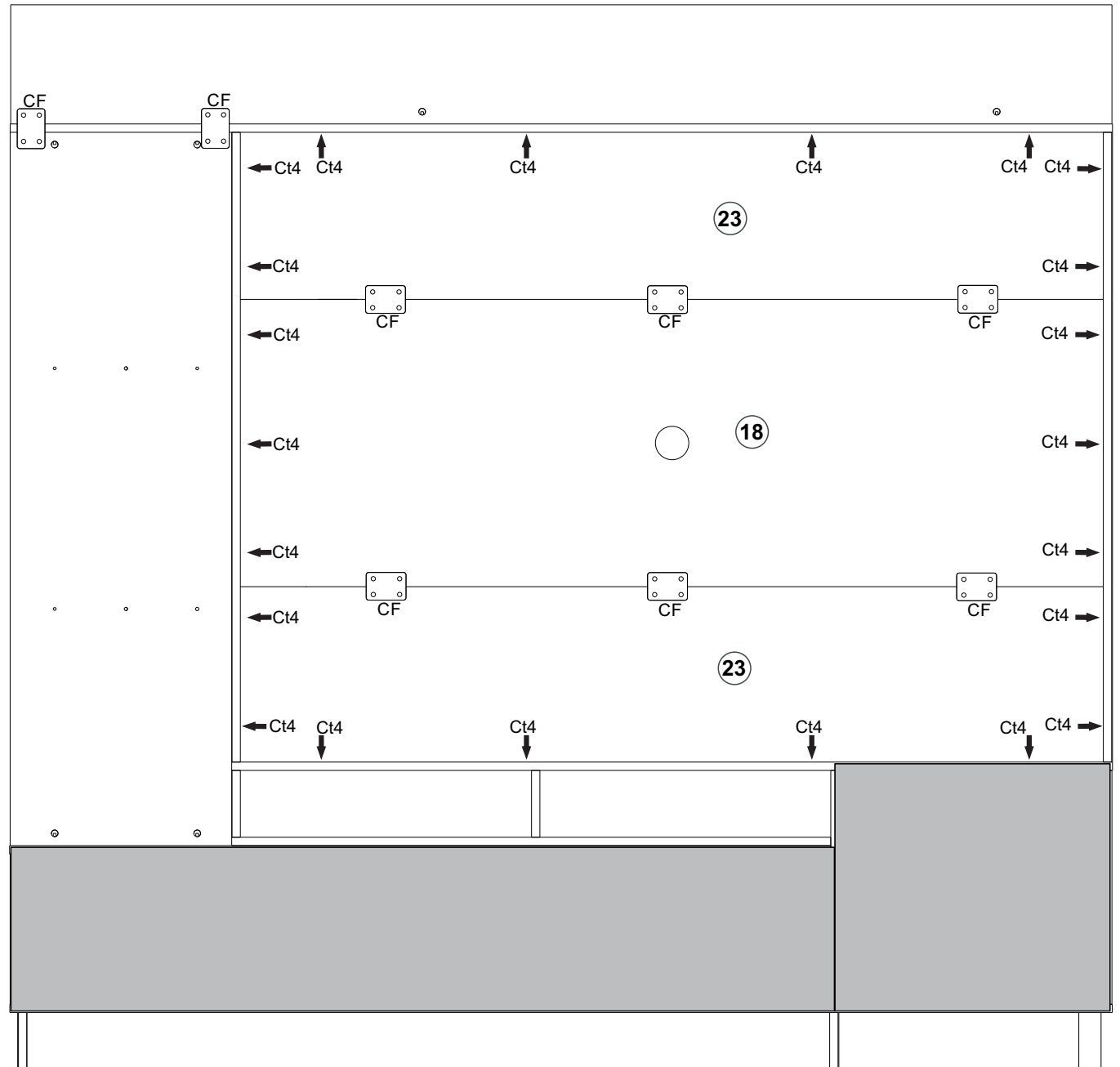

HO5120 - HOME

Manual de Montagem
 Assembly Instructions
 Instrucción de Montaje



22°

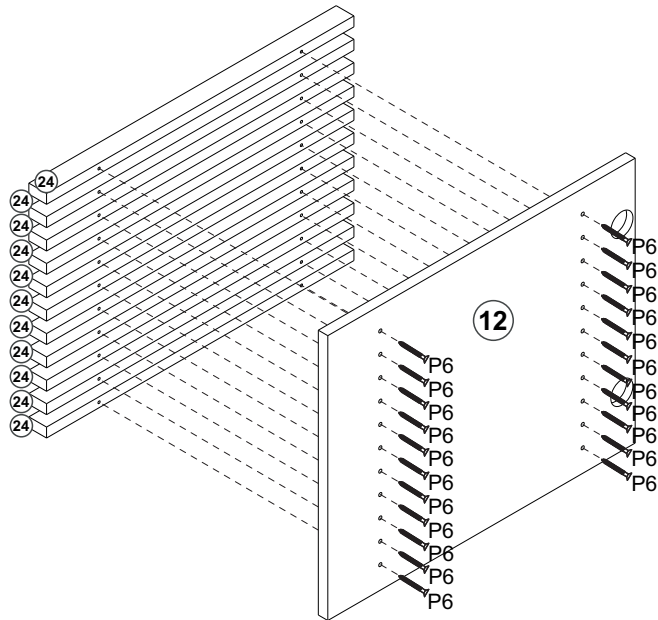

P6
 22 UN

23°

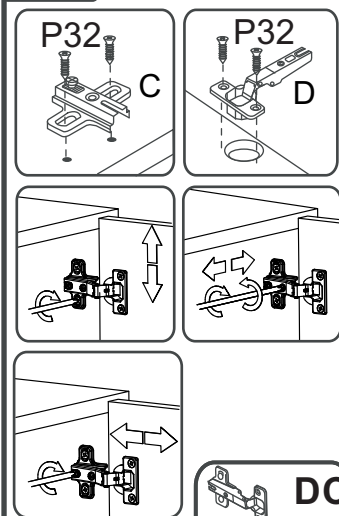

DC
 02 UN

P32
 08 UN

24° 2X

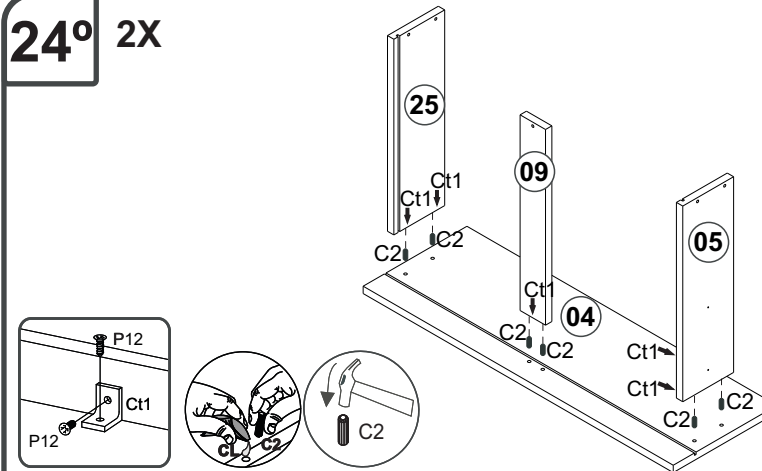

Ct1
 05 UN

P12
 10 UN

C2
 06 UN

2X

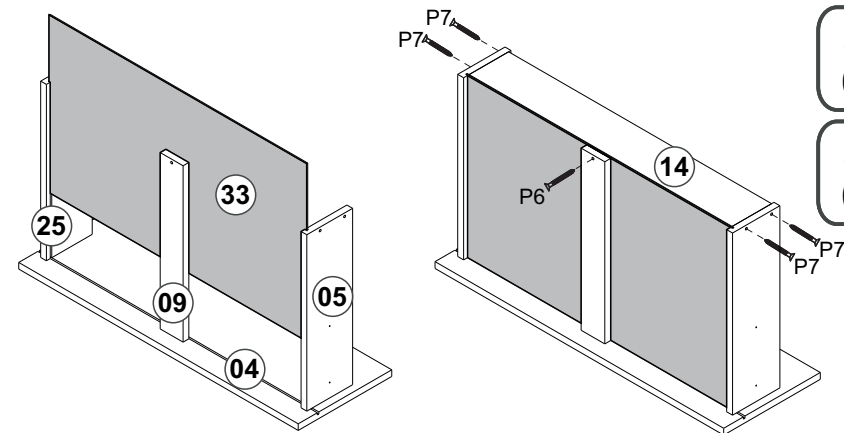

P6
 01 UN

P7
 04 UN

2X

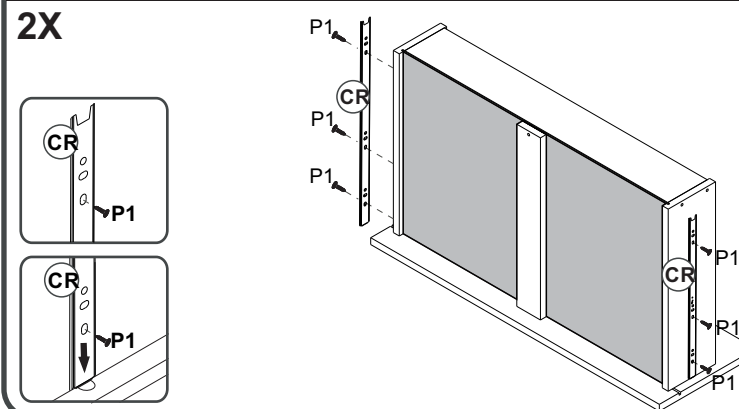

P1
 06 UN

Cr
 01 UN

HO5120 - HOME

25°

HO5120/E

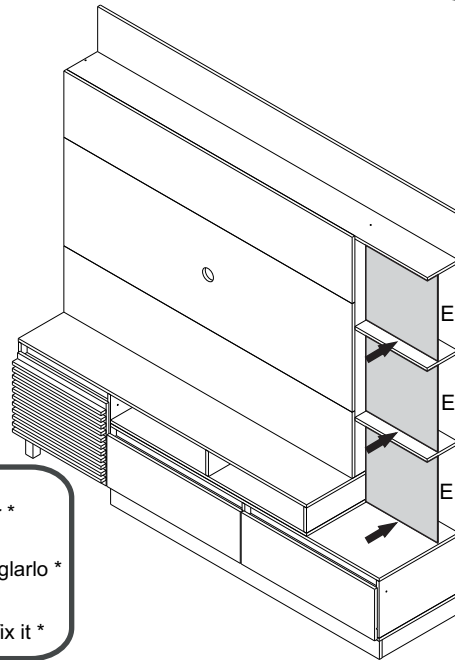

- ATENÇÃO!!!! montadores e consumidores**
 * Tirar a proteção da fita de trás do espelho para poder fixar *
- ATENCIÓN!!!! montadores e consumidores**
 * Retire la protección de la cinta detrás del espejo para arreglarlo *
- ATTENTION!!!! assemblers and consumers**
 * Remove the protection from the tape behind the mirror to fix it *

26°

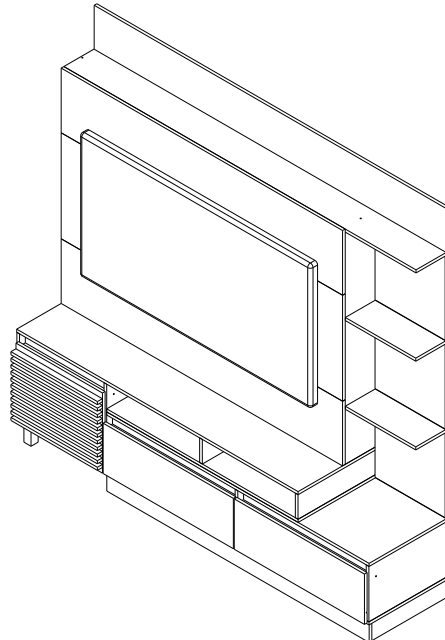

- ATENÇÃO!!!! montadores e consumidores**
 * Espaço útil para TV de até 65 polegadas *
- ATENCIÓN!!!! montadores e consumidores**
 * Espacio útil para TV de hasta 65 pulgadas *
- ATTENTION!!!! assemblers and consumers**
 * Usable space for TV up to 65 inches *

27°

PESO SUPORTADO/PESO SOPORTADO/ WEIGHT SUPPORTED

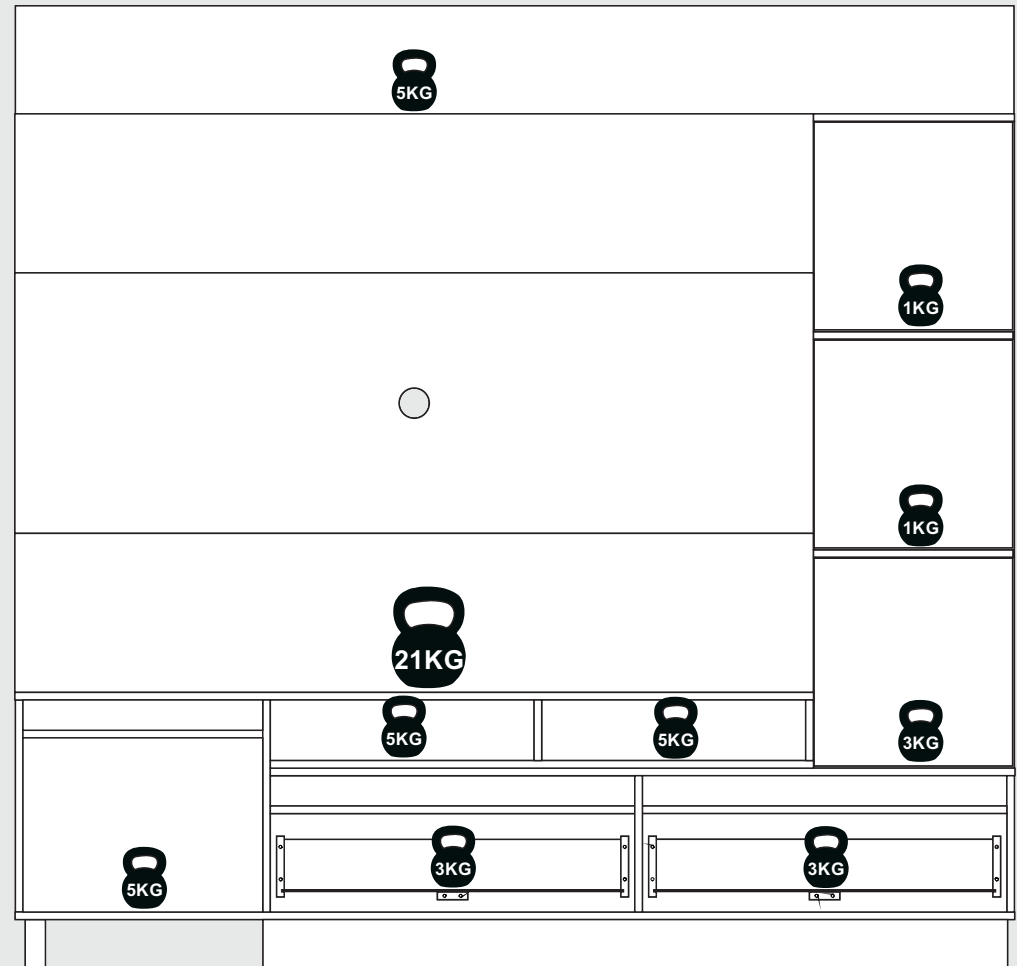

HO5120 - HOME

Manual de Montagem Assembly Instructions Instrucción de Montaje



Relação de Peças/ Relación de Piezas/Parts List

Nº	CÓDIGO/CODE	DESCRIÇÃO/DESCRIPCIÓN/DESCRIPTION	QTD/CANT	VOL.	
1	0565263	BASE INF	1980X450X15MM	1	1
2	0565262	TAMPO SUP/TAPA/TOP	1980X185X15MM	1	1
3	0565266	PAINEL SUP/PANEL	1978X214X15MM	1	1
4	0565270	FRENTE GAVETA/FRENTE CÁJON DRAWER FRONT	732X245X15MM	2	1
5	0565275	LATERAL GAVETA ESQ/LATERAL CÁJON DRAWER SIDE	400X120X15MM	2	1
6	0565252	LATERAL DIR MENOR/LATERAL/SIDE	450X120X15MM	2	1
7	0565264	LATERAL ESQ SUP/LATERAL/SIDE	1131X185X15MM	1	1
8	0565265	LATERAL DIR SUP/LATERAL/SIDE	1131X185X15MM	1	1
9	0565277	TRAVESSA INF GAV/PLATTER/PLATO	400X60X15MM	2	1
10	0565246	RODAPÉ FRT/ZÓCALO/BASEBOARD	1475X100X15MM	1	1
11	0565251	LATERAL DIREITA/LATERAL/SIDE	450X270X15MM	1	1
12	0565273	PORTA/PUERTA/DOOR	486X390X15MM	1	1
13	0565249	LATERAL ESQUERDA/LATERAL/SIDE	450X420X15MM	1	1
14	0565276	BATENTE/RÉVES CÁJON/DRAWER BACK	667X100X15MM	2	1
15	0565247	RODAPÉ TRS/ZÓCALO/BASEBOARD	1443X100X15MM	1	1
16	0565255	DIVISORIA/DIVIDER	450X420X15MM	1	1
17	0565257	TAMPO INF/TAPA/TOP	1475X450X15MM	1	1
18	0565261	PAINEL MAIOR/PANEL	1582X516X15MM	1	2
19	0565256	BASE INF MENOR	1076X450X15MM	1	2
20	0565258	DIVISORIA INF/DIVIDER	450X270X15MM	1	2
21	0565267	PRATELEIRA/ESTANTE/SHELF	396X168X15MM	1	2
22	0565268	TRAVESSA MAIOR/PLATTER/PLATO	722X60X15MM	2	2
23	0565260	PAINEL MENOR/PANEL	1582X315X15MM	2	2
24	0565554	RIPADO/RIPPED/LISTONES	484X28X15MM	11	2
25	0565274	LATERAL GAVETA DIR/LATERAL CÁJON DRAWER SIDE	400X120X15MM	2	2
26	0565259	PAINEL TRASEIRO/PANEL	1281X398X15MM	1	2
27	0565248	RODAPÉ LATERAL/ZÓCALO/BASEBOARD	420X100X15MM	2	2
28	0565272	TRAVESSA MENOR DEITADA/PLATTER/PLATO	475X60X15MM	1	2
29	0565271	TRAVESSA MENOR/PLATTER/PLATO	475X60X15MM	1	2
30	0565250	TAMPO/TAPA/TOP	1582X450X15MM	1	2
31	0565269	TRAVESSA MAIOR DEITADA/PLATTER/PLATO	722X60X15MM	2	2
32	0565280	COSTA PORTA/REVÉS/BACK	494X444X2, 8MM	1	2
33	0565278	FUNDO GAVETA/FONDO CÁJON/ DRAWER BOTTOM	675X403X2, 8MM	2	2
34	0565279	COSTA GAV/REVÉS/BACK	1479X294X2, 8MM	1	2

Ferramenta necessária
Necessary tools
Herramientas necesarias



ATENÇÃO!!!! montadores e consumidores

* Ajustar o torque da parafusadeira para não danificar as peças escareando o parafuso *

ATENCIÓN!!!! montadores e consumidores

* Ajuste el torque del destornillador para no dañar las piezas avallando el tornillo *

ATTENTION!!!! assemblers and consumers

* Adjust the torque of the screwdriver so as not to damage the parts by countersinking the screw *

www.decibal.com.br

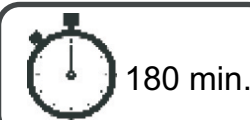

180 min.



ATENÇÃO!!!! montadores e consumidores

* Para limpar o móveis utilize somente um pano úmido (umedecido em água pura ou água com sabão neutro). Depois, passe um pano seco. Evite a umidade excessiva.

* Evite usar álcool, água sanitária, detergente e outros produtos químicos, mesmo diluídos em água. Não utilize produtos abrasivos de nenhuma espécie

ATENCIÓN!!!! montadores e consumidores

* Para limpiar el mueble utilice solamente un paño húmedo (humedecido con agua limpia o con un jabón suave). A continuación, utilice un paño seco. Evite el exceso de humedad.

* Evite uso de alcohol, hipoclorídoro solución basada, detergente y otros productos químicos, mismo diluídos en agua. No utilice productos abrasivos de ningún tipo.

ATTENTION!!!! assemblers and consumers

*To clean the furniture, use only a damp cloth (humidify it only in pure water or water and neutral soap).After, use a dry cloth.Avoid excessive humidity. *Avoid using alcohol, bleach, detergent and other chemical products, even diluted in water. Do not use any kind of abrasive cleaning agents to clean the furniture.











The use of such products may jeopardize the ?nal characteristics of the furniture.

HO5120 - HOME



Manual de Montagem
 Assembly Instructions
 Instrucción de Montaje



Escala (1:1)

LEGENDA	DESCRIÇÃO/DESCRIPCIÓN/DESCRIPTION	CÓDIGO	QUANT.
P1	 PARAFUSO/TORNILLO/SCREW 3,5X12	01328	24
P5	 PARAFUSO/TORNILLO/SCREW 4X25	01317	02
P6	 PARAFUSO/TORNILLO/SCREW 4X35	02032	35
P7	 PARAFUSO/TORNILLO/SCREW 4X45	01318	43
P8	 PARAFUSO/TORNILLO/SCREW 5X45	01320	02
P11	 PARAFUSO/TORNILLO/SCREW 4,5X60	08123	04
P12	 PARAFUSO/TORNILLO/SCREW 3,5X13	09927	196
P32	 PARAFUSO/TORNILLO/SCREW 4X14	12412	08
M1	  PARAFUSO/TORNILLO/SCREW MINIFIX	01314	02

Escala (1:1)

LEGENDA	DESCRIÇÃO/DESCRIPCIÓN/DESCRIPTION	CÓDIGO	QUANT.
C2	 CAVILHA/TARUGO/DOWEL 6X30 MM	01211	55
C3	 CAVILHA/TARUGO/DOWEL 6X50 MM	01212	10
Pr1	 PREGO/CLAVO/NAIL 10X10	01330	60

Medida em mm











HO5120 - HOME



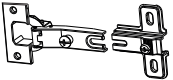

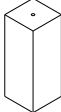
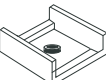
Manual de Montagem
Assembly Instructions
Instrucción de Montaje

decibal[®]

Escala (N/A)

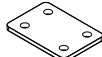
LEGENDA	DESCRIÇÃO/DESCRIPCIÓN/DESCRIPTION	CÓDIGO	QUANT.
CL	 COLA/PEGAMENTO/GLUE	01213	01
ET	 ETIQUETA LOGO DECIBAL/LABEL DECIBAL	01312	01
Ct1	 CANTONEIRA/PIEZA L/SHEET	03077	38
FX	FIXADOR COSTA/FIJADOR FONDO/ FIXER COAST 	01331	03
DC	 DOBRADIÇA/BISAGRA/HINGE D=35mm C=0mm	09449	02
AD	 ADESIVO/ADHESIVO/ADHESIVE	22MM	02
AD	 ADESIVO/ADHESIVO/ADHESIVE	15MM	05
PE	 PÉ/PATA/FOOT	12959	02
Pe1	 PÉ/PATA/FOOT	01367	08
CR	 CORREDICA/CORREDERA/METÁLIC SLIDE LARG	02641	02

Escala (N/A)

LEGENDA	DESCRIÇÃO/DESCRIPCIÓN/DESCRIPTION	CÓDIGO	QUANT.
CL	 CHAPA FIXAÇÃO/FIJACIÓN DE LA PLACA/ PLATE FIXATION	07751	08
PF	 PASSA FIO 60MM/PASA EI ALAMBRE 60MM/PASS WIRE 60MM	03967	01
B	BUCHA/BUJE/BUCHING 	02734	12
Ct4	 CANTONEIRA/PIEZA L/METAL SHEET 55X18MM	03110	22

HO5120/E

LEGENDA	DESCRIÇÃO/DESCRIPCIÓN/DESCRIPTION	CÓDIGO	QUANT.
E	 ESPELHO/ESPEJO/MIRROR 412X394X3MM	12958	03